

Remedial Design/Remedial Action Work Plan

Former North Water Street MGP Site
Poughkeepsie, Dutchess County, New York
Site No.: C31-40-70

August 2018

Quality information

Prepared by

Tina Liu, P.E.

Checked by

Shail Pandya, Sr. Project Manager

Approved by

Michael Spera, P.E., VP

Revision History

Revision	Revision date	Details
0	02/2018	Initial
1	08/2018	First revision

Distribution List

# Hard Copies	PDF Required	Association / Company Name
Yes	Yes	New York State Department of Environmental Conservation, Division of Environmental Remediation
Yes	Yes	New York State Department of Health
Yes	Yes	New York State Department of Environmental Conservation, Division of Permitting
No	Yes	United States Army Corp of Engineering
No	Yes	Central Hudson Gas and Electric Corp

Prepared for:

Central Hudson Gas & Electric Corporation
284 South Avenue
Poughkeepsie, New York 12601

Prepared by:

Shail Pandya
Sr. Project Manager, Associate Vice President
T: 212.377.8708
M: 718.309.5643
E: shail.pandya@aecom.com

AECOM
125 Broad Street, 15th floor
New York, NY, 10004
aecom.com

Copyright © 2018 by AECOM

All rights reserved. No part of this copyrighted work may be reproduced, distributed, or transmitted in any form or by any means without the prior written permission of AECOM.

Table of Contents

1.	Introduction	10
1.1	DER-10 Requirements.....	12
1.2	Site Background	12
1.2.1	Site Location and Description	12
1.2.2	Site Topography and Drainage	12
1.2.3	Site Geology and Hydrogeology	13
1.2.3.1	Site Geology	13
1.2.3.2	Upland Geology	13
1.2.3.3	River Geology	13
1.2.4	Site Hydrogeology	14
1.2.5	Tidal Elevations	14
1.3	Report Format	14
2.	Pre-Design Investigation Field Activities and Results	15
2.1	Landside Geotechnical Borings and Sample Collection	15
2.2	River Geotechnical Borings and Sample Collection	15
2.3	Subsurface Structures Investigation	16
2.3.1	Former Oil Storage Tank.....	16
2.3.2	Former Tar Centrifuge House	16
2.3.3	Former Oil and Tar Tanks	16
2.4	Barrier/Bulkhead Wall Test Pit Investigation	17
2.5	Sediment Investigation	17
2.6	Dewatering Bench Scale Study	17
2.7	Disposal Facility Pre-Characterization Borings and Sample Collections	17
2.7.1	Landside Excavation	17
2.7.2	Sediment Dredging.....	17
2.8	Utility Locate	18
2.9	Bathymetric and Landside Survey	18
2.10	Air Monitoring	18
2.11	Biological Assessment and Essential Fish Habitat Analysis	18
3.	Remedial Design and Remedial Action Work Plan	20
3.1	Remedial Goals	20
3.2	Mobilization and Site Preparation	20
3.2.1	Site Preparation	20
3.2.2	Alternate Site Access Road	20
3.2.3	Erosion and Sediment Controls	21
3.2.4	Turbidity Curtains.....	21
3.2.5	Site Facilities	21
3.2.6	Surveying.....	21
3.2.7	Utility Protection.....	21
3.2.8	Marine and Land Traffic Management	22
3.3	Landside Remedy (Phase I)	22
3.4	Barrier/Bulkhead Wall Installation (Phase II)	22
3.5	River Slope Regrading (Phase III)	24
3.6	In-River Dredging and Restoration (Phase III).....	25
3.6.1	Best Management Practices.....	25
3.7	Reactive Core Mat River Slope Capping (Phase III).....	26

3.8	Reactive Core Mat Utility Capping (Phase III)	27
3.9	Decontamination	27
3.10	Solid Waste Management	27
3.10.1	On-Site Waste Management	27
3.10.2	Waste Characterization	28
3.10.3	Off-Site Transportation	28
3.10.4	Off-site Disposal or Treatment	28
3.11	Water Management	29
3.11.1	Water Treatment	29
3.12	Site Restoration	30
3.12.1	Landside	30
3.12.2	River	30
3.12.3	River Slope Restoration	30
3.12.4	Habitat Restoration and Enhancement	31
3.12.5	Mitigation	31
3.13	NAPL Collection (Phase IV)	31
4.	Permitting and Regulatory Requirements	33
4.1	Permitting	33
4.2	Regulatory Requirements	33
4.2.1	Occupational Safety and Health Regulations	33
4.3	Transportation Requirements	34
5.	Quality Assurance & Quality Control	35
5.1	QA/QC Procedures	35
5.1.1	In-River Dredging	35
5.1.2	River Slope and Utility Capping	35
5.1.3	Waste Management	36
5.1.4	Water Management	36
5.1.5	Site Restoration	37
5.2	Environmental Monitoring and Controls	37
5.2.1	Water Quality Control and Monitoring Plan	37
5.2.1.1	Background Monitoring	37
5.2.1.2	Work Approach	38
5.2.1.3	Water Quality Monitoring Approach	41
5.2.1.4	Contingency Plan, Mitigation, and Response	42
5.2.2	Odor, Vapor, and Dust Control	44
5.2.3	Air Monitoring	44
5.2.4	Erosion and Sediment Control	44
5.2.5	Noise and Vibration Evaluation	44
6.	Schedule	45
7.	References	46

Figures

Figure 1-1	Site Location Map
Figure 1-2A	Upland Site Layout Map/Existing Conditions
Figure 1-2B	Hudson River Site Layout Map/Existing Conditions
Figure 1-3	Location of Navigational Channel and River Intake
Figure 2-1	PDI Geotechnical Boring Locations
Figure 2-2	Subsurface Structures/ Obstructions Investigation Locations
Figure 2-3	Sediment Dredge Limits Delineation Sample Locations
Figure 2-4	Sediment Disposal Facility Pre-characterization Sampling Locations
Figure 2-5	Bathymetric Survey
Figure 3-1	Site Control Map – Landside Construction Operations
Figure 3-2	Site Controls Details
Figure 3-3	Site Control Map – Waterside Construction Operations
Figure 3-4	Sediment Dredge Containment Cell Plan View
Figure 3-5	Sediment Dredge Containment Cell Side View
Figure 3-6	Landside Excavation Plan
Figure 3-7	Barrier/Bulkhead Wall Alignment
Figure 3-8	Barrier/Bulkhead Wall Profile View
Figure 3-9	River Slope Grading Plan
Figure 3-10A	River Slope Grading Cross Sections
Figure 3-10B	River Slope Grading Cross Sections
Figure 3-11	River Sediment Dredge Plan
Figure 3-12	River Sediment Dredge Cross Sections
Figure 3-13	River Slope Cap and Utility Cap Location Plan
Figure 3-14	River Slope Cap and Utility Cap Cross Sections
Figure 3-15	River Slope and Utility Cap Details
Figure 3-16	Water Treatment Plant Process Flow Diagram
Figure 3-17	Landside Restoration Plan
Figure 3-18	Landside Restoration Cross Section
Figure 3-19	Sediment Dredge Backfill and Restoration Plan
Figure 3-20	Sediment Dredge Backfill and Restoration Cross Sections

Appendices

Appendix A	2016 New York State Department of Environmental Conservation Decision Document
Appendix B	Community Environmental Response Plan
Appendix C	Pre Design Investigation Geotechnical Boring Logs and Sediment Precharacterization Observation Logs
Appendix D	Pre Design Investigation Geotechnical Samples Laboratory Results
Appendix E	Pre Design Investigation Test Pit Excavation Photo Log
Appendix F	Pre Design Investigation Bathymetry and Sidescan Survey Report
Appendix G	Pre Design Investigation Community Air Monitoring Report Results (E-Format Only)
Appendix H	Essential Fish Habitat Analysis and Biological Assessment Reports
Appendix I	United States Army Corps of Engineers Nationwide Permit No. 3 Joint Application (E-Format Only)
Appendix J	United States Army Corps of Engineers Nationwide Permit No. 38 Joint Application (E-Format Only)

Acronyms and Abbreviations

ADT	Advanced Drilling Technology
AECOM	AECOM USA, Inc.
ATL	Atlantic Testing Laboratory
BCA	Brownfield Cleanup Agreement
BMP	Best Management Plan
CAMP	Community Air Monitoring Plan
CHGE	Central Hudson Gas & Electric Corporation
CPP	Citizen's Participation Plan
DER	Declaration of Environmental Remediation
DNAPL	Dense Non-Aqueous Phase Liquid
DOT	Department of Transportation (U.S.)
EA	EA Science and Technology, Inc.
EFH	Essential Fish Habitat
FER	Final Engineering Report
GARFO	Greater Atlantic Regional Fisheries Office
HASP	Health and Safety Plan
HSA	Hollow Stem Auger
IC/EC	Institutional Controls and Engineering Controls
MGP	Manufactured Gas Plant
msl	Mean sea level
NAPL	Non-aqueous phase liquid
NAVD 88	North American Vertical Datum of 1988
NGVD	National Geodetic Vertical Datum
NYCRR	New York Codes, Rules and Regulations
NYSDEC	New York State Department of Environmental Conservation
NYSDOH	New York State Department of Health
OSHA	Occupational Safety and Health Administration
OVDPCP	Odor, Vapor, and Dust Control Plan
PAH	Polycyclic Aromatic Hydrocarbons
PCBs	Polychlorinated Biphenyl
PDI	Pre-Design Investigation
PID	Photoionization Detector
PPE	personal protective equipment
PVC	Polyvinyl Chloride
QA/QC	Quality Assurance/Quality Control

RA	Remedial Action
RAA	Remedial Alternative Analysis Report
RCM	Reactive Core Mats
RD	Remedial Design
RI Report	Remedial Investigation Report
River	Hudson River adjoining the site
SCGs	Standards, Criteria, and Guidance
SCO	Soil Cleanup Objectives
SHPO	State Historic Preservation Office
Site	Former North Water Street MGP Site, Poughkeepsie, New York
SMP	Site Management Plan
SPDES	State Pollutant Discharge Elimination System
SPT	Standard Penetration Testing
SVOCs	Semivolatile Organic Compounds
TCLP	Toxicity Characteristic Leaching Procedure
TPH	Total Petroleum Hydrocarbons
TSS	Total Suspended Solids
USACE	United States Army Corps of Engineers
VOCs	Volatile Organic Compounds
WOTH	Walkway Over The Hudson

Measurements

bgs	Below Ground Surface
BTU	British Thermal Unit
cy	Cubic Yards
NTUs	Nephelometric turbidity units
ppm	Parts per Million
ug/m ³	Micrograms per Cubic Meter

1. Introduction

AECOM USA Inc. (AECOM), on behalf of Central Hudson Gas & Electric Corporation (CHGE) has prepared this Remedial Design (RD)/Remedial Action (RA) Work Plan (Work Plan) to implement a RA on the former CHGE North Water Street manufactured gas plant (MGP) site (site) located in Poughkeepsie, Dutchess County, New York (Figure 1-1). The New York State Department of Environmental Conservation (NYSDEC), in consultation with the New York State Department of Health (NYSDOH), has selected the remedy for the site, as established in the 2016 Decision Document (NYSDEC, 2016). The RD and the RA detailed in this Work Plan are being completed in accordance with the NYSDEC Decision Document and the Brownfield Cleanup Agreement (BCA) Index Number D3-0004-99-04 executed between CHGE and the NYSDEC in May 2005.

Multiple Remedial Investigation (RI) Reports and a Remedial Alternative Analysis Report [(RAA); Arcadis, 2014] were completed for the site and approved by the NYSDEC. The RAA proposed removal and capping of on-site shallow contaminated material and in-river visibly contaminated source material, construction of a subsurface vertical non-aqueous phase liquid (NAPL) barrier wall, NAPL recovery, capping of sediments to prevent NAPL migration, restoration, institutional controls, and a Site Management Plan (SMP). NYSDEC subsequently approved the RAA recommendations for implementation in the Decision Document. A summary of the components of the remedy as specified in the Decision Documents (Appendix A) are as follows:

- a remedial design program to provide the details necessary to implement the remedy;
- excavation and off-site disposal of upland shallow contaminant areas, located in the northern portion of the lower terrace area of the site;
- a subsurface barrier wall will be installed along the east bank of the Hudson River to prevent the migration of NAPL to the river;
- installation of several passive NAPL recovery wells;
- focused solidification of soil horizons containing NAPL will be performed to prevent migration of NAPL toward the river;
- dredging of NAPL contaminated sediments from the Hudson River channel where feasible;
- capping of visibly contaminated sediments in place along the Hudson River bank adjacent to the site and near and above the utility crossings;
- placement of a cover system to allow industrial use of the site;
- site restoration, including establishment of vegetation by seeding and installation of concrete or pavement surfaces;
- development of a SMP to address residual contamination, evaluate buildings for soil vapor impacts, address any use restrictions, and provide for the operation, maintenance, and monitoring of components of the remedy;
- imposition of an institutional control in the form of an environmental easement; and
- periodic certification of the institutional and engineering controls.

As a part of the remedial design program, a pre-design investigation (PDI) was completed at the site and in the Hudson River in June 2017 and December 2017 to provide design data for the subsurface barrier/bulkhead wall, sediment dredging and associated dewatering system, river slope capping, and to address potential data gaps along the proposed sediment dredge perimeter. In addition, the PDI also included soil and sediment pre-characterization for disposal to a thermal facility and an evaluation of the free drainage potential of the sediments for dewatering purposes. A summary of the PDI is included as Section 2 of this Work Plan. The PDI results established the extent of the southernmost dredge prism and the depth of the barrier/bulkhead wall to a maximum of 50 feet below ground surface (bgs) or bedrock whichever is shallower.

In accordance with the BCA and the DER-10, Technical Guidance for Site Investigation and Remediation [(DER-10); NYSDEC, 2010], the remedial design program for implementation of the remedial action consists of the following documents:

- Remedial Design Report (This Work Plan is submitted in lieu of the RD Report);
- Issued for Construction design documents for the RD (will be submitted separately under CHGE cover upon attainment of permits);
- Protocols to determine the effectiveness of the RD (Section 5 of this Work Plan);
- Schedule to implement the RD (Section 6 of this Work Plan);
- Contingency Plan (Section 5 of this Work Plan); and
- Construction Health and Safety Plan [(HASP), will be submitted separately under CHGE cover for informational purposes].

NYSDEC in consultation with CHGE developed a Citizen Participation Plan describing the citizen participation activities that have been or will be completed for the site. Consistent with NYSDEC Program Policy DER-23, Citizen Participation Handbook for Remedial Programs, a Notice and Fact Sheet will be sent to the site contact list before field work begins. CHGE will work with the NYSDEC (as appropriate) to develop the notice that will be sent to all parties on the site contact list (i.e., residents and business owners within a specified radius of the site, as well as additional community and political personnel) and to the document repository. The notice will include a Fact Sheet that describes the upcoming remediation work. The following additional documents were not explicitly required by the BCA but are integral to the remedial design program:

- Community Environmental Response Plan (Included as Appendix B of this Work Plan) including –
 - Community Air Monitoring Plan (CAMP);
 - Marine and Land Activity Transportation Plan (pending finalization of this Work Plan and permit approvals, will be submitted separately under CHGE cover for informational purposes);
 - Odor, Vapor and Dust Control Plan (OVDCP);
 - Water Quality Monitoring Plan (Section 5 of this Work Plan);
 - Noise Monitoring Plan; and
 - Vibration Settlement Plan.
- Permitting Plan and associated permits and review correspondence (Section 4 of this Work Plan).

Due to construction logistics and existing site conditions, implementation of this remedy will be performed in the following phases:

- the first phase of the remedy (Landside Excavation) will involve excavation and off-site disposal of the on-site soils and debris, site restoration including placement of a site wide cover system, and preparation for the subsequent phases of the remedy.
- the second phase of the remedy (Barrier/Bulkhead Wall Installation) will involve installation of a subsurface barrier wall and a structural bulkhead wall along the western portion of the site adjacent to the Hudson River.
- the third phase of the remedy (In-River Remedy Implementation) will include dredging and sediment capping in the Hudson River.
- in the fourth phase of the remedy (NAPL Collection), NAPL recovery wells will be installed to collect and remove any remaining NAPL from the subsurface.
- in the fifth phase of the remedy (Development of SMP and Final Engineering Report [FER]), post construction, a SMP and FER will be submitted in accordance with the BCA and the Decision Document and any required institutional controls will be imposed. The SMP will include a schedule for operation, maintenance, and monitoring of components of the remedy and for the submission of the periodic certification of the institutional and engineering controls. The FER will include details of the implementation of this Work Plan and summary of previously completed RAs, remaining site contamination, and controls implemented to manage the remaining contamination.

Design, construction, and physical site condition constraints require the implementation of the phases of the remedy to take place consecutively from the first phase to the fifth phase though flexibility has been incorporated into the sequencing to allow one or more phases to be completed simultaneously.

1.1 DER-10 Requirements

To satisfy the requirements stated in Section 5.2 (b) of DER-10, the Decision Document has been included with this document as Appendix A. The following DER-10 requirements are included in the Decision Document:

- summary of the findings and recommendations detailed in the RI Reports and the RAA;
- summary of sampling results collected to date of the publication of the Decision Document;
- identification of all applicable standards, criteria, and guidance (SCGs);
- figure(s) detailing location, depth, and parameters of all contaminants in excess of the remediation standard;
- figure detailing wetlands, streams or other habitats potentially impacted by the remedial action; and
- figure showing the vertical and horizontal extent of the area to be remediated.

As mentioned earlier, a summary detailing the results of the PDI is included as Section 2.

1.2 Site Background

1.2.1 Site Location and Description

The site is located in the city of Poughkeepsie, Dutchess County, New York (Figure 1-1). Figures 1-2A and 1-2B present the current site and offsite layout with the locations of former MGP structures. The site is approximately 7 acres in size and is fenced on the northern, eastern, and southern sides. Currently, CHGE operates a natural gas regulator station on the northwest portion of the site and an electric transition and substation on the southern/eastern portion of the site. Most of the site has a gravel cover or is paved.

Dutchess Avenue is located immediately north of the site, North Water Street and Amtrak railroad lines are located immediately east of the site, the Hudson River is located immediately west of the site, and the City of Poughkeepsie Upper Landing Park and Fall Kill Creek is located just south of the site (Figures 1-2A and 1-2B). To the north of Dutchess Avenue lies a property currently under development, which is the site of the former A.C. Dutton Lumber Yard (NYSDEC Site No. C314081). The site is zoned I-2, a general industrial district (Dutchess County Department of Planning and Development, 2015).

A public water supply from the Hudson River (the water supply intake is located approximately 0.75 miles north of the site) serves the town and city of Poughkeepsie and is shown in Figure 1-3. Based on the findings of the Phase I Investigation, the majority of the area within a 3-mile radius of the site uses the City of Poughkeepsie public water supply from the Hudson River and the nearest water supply well is located 1.8 miles north of the site (EA Science and Technology [EA], 1987). According to the Dutchess County Department of Health, there are no wells used for drinking water within one mile of the site (Blasland, Bouck & Lee, Inc. 2000).

1.2.2 Site Topography and Drainage

Topographic relief at the site ranges from approximately 5 feet (NGVD 1929) along the river to approximately 65 feet (NGVD 1929) along North Water Street. The site is divided into upper (eastern) and lower (western) portions by a north-south trending bedrock cliff located approximately 100 feet east of the river.

Storm water generally flows west across the site towards the Hudson River. The Hudson River (river) is designated as Class A waters. According to 6 New York Codes, Rules and Regulations (NYCRR) Parts 701 and 858, Class A waters shall be suitable for fish propagation and survival; water supply source for drinking, culinary, or food processing purposes; primary and secondary contact recreation; and fishing. Tidal movements affect the river and, during periods of low discharge, the fresh/salt water interface extends to the Poughkeepsie area (Frimpter, 1972).

1.2.3 Site Geology and Hydrogeology

1.2.3.1 Site Geology

Section 3.3 of the RI Report (Arcadis, 2010) discuss the site-specific geology in detail and is summarized below. The RI Report (RI Report Figures 10A through 10K) presents the Geologic cross sections depicting the geology. Detailed soil and sediment boring logs, complete with geologic descriptions, were included in Attachments C and H, respectively, of the RI Report.

1.2.3.2 Upland Geology

The observed overburden is primarily fill materials, consisting of shale fragments mixed with gravel, sand and silt, with lesser amounts of anthropogenic materials (e.g., bricks, concrete, cinders, coal, ash, glass, wood). The overburden thickness in the upper portion of the site is generally 5 feet or less. Within the lower portion of the site, the overburden forms a wedge that is thicker (20 to 60 feet) toward the river and thins to 1 to 5 feet in thickness adjacent to the bedrock cliff that separates the lower and upper portions of the site.

Within the overburden in the lower portion of the site, silt and clay lenses were observed between wells NMW-111S and NMW-113S (in the general area where a clay dike was installed to mitigate the seepage of MGP NAPLs into the river in the 1940s) and between wells NMW-115S and NMW-119D, with some other minor lenses observed. A more significant and thicker silt and clay layer is present in the northern section of the lower portion of the site (i.e. north of well NMW-109S) between the fill unit and the shale bedrock. This silt and clay layer thickens from 5 to 25 feet and deepens by approximately 20 feet between wells NMW-110S and NMW-117S, and thickens from 15 to 25 feet and deepens by approximately 15 feet between wells NMW-117S and NMW-120S. The silt and clay layer is deepest near well NMW-117S as compared to adjacent borings to the north, east, and south, resulting in a small depression within the surface of the silt and clay layer in this area.

Within the overburden, wood zones were also encountered, and a few of these zones were approximately 10 feet in length. These wood zones likely represent pilings for former docks and other site structures and/or tie backs for the current and former bulkheads along the river. Wood zones were more prevalent in the northern section of the lower portion of the site (i.e., north of the location of well NMW-109S). Between wells NMW-109S and NMW-114S, the wood zones penetrate into or through the silt and clay layer.

Bedrock at the site consists of dark grey, deformed, or low-grade metamorphic shale. During the Phase II investigation, a one-foot interval of greywacke was encountered at location MW-1, but was not observed at locations MW-2 and MW-3, or at other subsequent locations drilling in the lower portion of the site. The bedrock is highly deformed, exhibiting contorted bedding planes and healed fracture zones. The features observed in the bedrock cores, such as fine-grained minerals with cleavage patterns, suggested that the shale had undergone low-grade metamorphism, rendering the shale to a slate or possibly a phyllite. Evidence of original bedding features were observed in the cores and are often preserved during low-grade metamorphism. Physical characteristics included calcite stringers, calcite banding, peltic inclusions, and vugs. In general, the bedrock exhibited low primary porosity and secondary porosity in the form of fractures and fracture zones.

In general, the inclination of the fractures observed in bedrock cores ranged from 10 to 75 degrees from the horizontal. The fracture surfaces ranged from smooth to irregular and rough. The bedrock can be observed outcropping as cliffs at several locations at the site. Observations of the bedding planes and cleavage in the outcrops at the site also indicate that the bedrock has undergone deformation and low-grade metamorphism. A layer of weathered bedrock is present above the competent bedrock in some areas. A top of bedrock contour map was provided as Figure 11 in the RI Report.

1.2.3.3 River Geology

Near shore sediments are comprised primarily of the same fill materials observed in the overburden soils along the river, underlain by silt and silt/clay. The fill materials pinch out further into the river, and silt and silt/clay become the predominant sediment materials, with periodic sand lenses and organic layers.

During river reconnaissance activities conducted at low tide conditions on November 14, 2003 and September 15, 2004, rip rap was observed along a majority of the riverbank/shoreline and a wooden bulkhead were observed approximately 2 to 15 feet west of the existing property line.

Additional details on the river reconnaissance are included in the RI Report.

1.2.4 Site Hydrogeology

Groundwater is present in the overburden and bedrock at the site. In overburden wells installed in the lower portion of the site, groundwater has been measured at depths ranging from approximately 1 to 13 feet bgs. Groundwater has been measured in bedrock wells installed in the lower and upper portion of the site at depths ranging from approximately 0 to 14 feet bgs and 10 to 19 feet bgs, respectively.

Groundwater levels in monitoring wells located on western portion of the site are influenced by high and low tide in the river. The groundwater in the overburden is hydraulically connected with the river. Groundwater in the overburden and bedrock are also hydraulically connected.

The bedrock unit is designated as the primary aquifer of concern because the overburden is not saturated throughout the site, and the saturated area is not considered an aquifer that would yield usable amounts of water. The bedrock is reportedly used for water supply by several commercial and community supply wells. As indicated in Section 1.2.1, the majority of the area within a 3-mile radius of the site is supplied by public water that is drawn from the river approximately 0.75 miles north and hydraulically upgradient of the site, and the nearest water supply well is located 1.8 miles to the north and hydraulically upgradient of the site (EA, 1987).

Groundwater at the site generally flows to the west, towards the river. However, natural hydraulic gradients are sinusoidal, alternating positive (toward the river) and negative (away from the river), on the tidal frequency but shifted by approximately 6 hours.

1.2.5 Tidal Elevations

The Mean High Water, Mean Sea Level, and Mean Low Water elevations at the site are approximately 1.93 feet above the North American Vertical Datum of 1988 (NAVD 88), 0.23 feet NAVD 88, and -1.58 feet NAVD 88 respectively. The elevations are based on the National Oceanic and Atmospheric Administration (NOAA) website and derived from data collected in 2014 at station 85188951 - Hyde Park, New York located approximately 5 miles from the site. The Hyde Park, New York station is the nearest station to the site. The levels in meters above the Mean Lower Low Water datum can be found at the NOAA link below:

<https://tidesandcurrents.noaa.gov/benchmarks.html?id=8518951>

1.3 Report Format

Section 2 presents the summary of the PDI while Section 3 describes the Work Plan for the implementation of the first phase of the remedial design. All required permits and/or substantive permit requirements are provided in Section 4. The quality assurance project plan (QAPP) is summarized in Section 5 while Section 6 details the proposed schedule for the implementation of the remedial design program.

2. Pre-Design Investigation Field Activities and Results

The objectives of the PDI activities were to:

- provide design data for the barrier/ bulkhead wall design as well as to determine the stability of the river slope;
- investigate the former MGP structures within the former propane tank storage area;
- delineate sediment dredge area on the west perimeter of the southernmost dredge area (south of the Walkway Over the Hudson);
- precharacterize soil and sediments for disposal options;
- provide baseline terrestrial topographic and river bathymetry survey;
- conduct a bulkhead condition inspection;
- evaluate free drainage potential of sediments for dewatering purposes (to be completed in Spring of 2018);
- evaluate various sediment amendment materials (to be completed in Spring of 2018);
- provide data for the dewatering system; and
- locate and survey underwater utilities.

Field activities were completed between June 12 and 30, 2017 and in December 2017. PDI activities were completed both within and outside of the current site boundary. Field activities included soil and sediment boring advancement and sampling, test pit excavations, underwater diving, surveying, and air monitoring. Figures 2-1 through 2-5 provide the location of the PDI activities.

2.1 Landside Geotechnical Borings and Sample Collection

A total of five (5) geotechnical borings were advanced using hollow stem auger (HSA) methods in proximity of the proposed barrier/bulkhead wall alignment. Soil samples were collected to evaluate geotechnical parameters necessary for wall design. Prior to borehole advancement, locations were pre-cleared to between 4 and 5 feet below ground surface (ft bgs) with a hand auger or post hole digger. Borings were advanced to 50 feet bgs or to bedrock whichever was deeper. Geotechnical soil boring locations are shown in Figure 2-1.

All borings were completed by Aquifer Drilling and Testing (ADT) with a truck-mounted rig under the supervision of an AECOM geologist or environmental scientist. Continuous soil samples were collected using 2 foot split-spoon samplers according to Standard Penetration Testing (SPT) protocol. Soils were logged for composition, visible and olfactory impacts, and field screened with a photoionization detector (PID) for volatile organic compounds (VOCs). Boring logs are provided in Appendix C.

Geotechnical samples were collected from each location at a depth corresponding to the intended base of the barrier/bulkhead wall. A total of 15 geotechnical soil samples were collected during the PDI. Samples were taken directly from the split-spoon, double-bagged in one gallon size freezer bags, and sent under chain-of-custody protocol via courier to GeoTesting Express in Boxborough, Massachusetts and analyzed for particle size. Boreholes were tremie grouted upon completion. All soil cuttings were containerized in 55 gallon drums and disposed at an approved off-site facility. The results of the laboratory analyses for geotechnical samples are provided in Appendix D.

2.2 River Geotechnical Borings and Sample Collection

A total of four (4) geotechnical borings were advanced using HSA methods along the proposed barrier/bulkhead wall alignment. Soil samples were collected to evaluate geotechnical parameters necessary for barrier/ bulkhead wall design. Borings were advanced approximately 5 feet into bedrock. Geotechnical soil boring locations are shown in Figure 2-1.

All borings were completed by Atlantic Testing Laboratories (ATL) with a barge-mounted rig under the supervision of an AECOM geologist or environmental scientist. Continuous soil samples were collected using 2 ft split-spoon

samplers according to SPT protocol. Soils were logged for composition, visible and olfactory impacts, and field screened with a PID for VOCs. Boring logs are provided in Appendix C.

Geotechnical samples were collected from each location at a depth corresponding to the intended base of the barrier /bulkhead wall. A total of 12 geotechnical soil samples were collected during the PDI. Samples were taken directly from the split-spoon, double-bagged in one gallon size freezer bags, and sent under chain-of-custody protocol via courier to GeoTesting Express in Boxborough, Massachusetts and analyzed for particle size. Boreholes were tremie grouted upon completion. All soil cuttings were containerized in 55 gallon drums and disposed at an approved off-site facility. The results of the laboratory analyses for geotechnical samples are provided in Appendix D.

2.3 Subsurface Structures Investigation

One soil boring and three test pits were completed at locations presented in Figure 2-2 to further characterize the content and bottom of former subsurface structures and to evaluate the presence of obstructions along the barrier/bulkhead wall alignments.

ADT excavated two test pits (TP17-100 and TP17-101) within the area of the former fuel oil tanks, former tar and oil storage tanks and former tar centrifuge structure. Test pit TP17-100 was excavated to a depth of 15 to 17 feet bgs and test pit TP17-101 was excavated to a varying depth of 15 feet bgs which represents the surface of bedrock and/or groundwater. A photo log of the test pit activities is presented in Appendix E.

ATL completed one soil boring, SB17-100, using HSA technology within the footprint of the former oil storage tank to a depth of 24 feet bgs which represents the surface of bedrock.

2.3.1 Former Oil Storage Tank

The circular footer of the former Oil Storage Tank was detected at a depth of 7 feet bgs within both test pits. The footer was constructed of steel rebar reinforced concrete and extended to a depth of 16 feet bgs. A concrete pad was observed with the former oil tank in TP17-100 that extended the width of the test pit (5 feet) and at least 6 feet thick. The bottom of the concrete pad could not be determined due to difficulty in breaking through the pad. The materials observed within the former Oil Storage tank footer included fill material, sand, concrete and brick debris and piping. NAPL was not observed within the footer. Stained soils and slight oil odors were observed on the outside of the footer towards the bottom.

One-foot thick concrete foundations were observed in soil boring, SB17-100 at 4 feet bgs and 7.3 feet bgs respectively. NAPL was not observed within the structure in the soil boring. Black stained soils and slight MGP-like odors were detected at the bottom of the structure. Please note that the ground surface at SB17-100 is approximately 6 feet below the test pit grade. Fill, concrete, brick, and timber debris were observed within the boring below the bottom of the structure to depth. Heavily coated NAPL with strong MGP-like odors were observed in the boring below the structure foundation from a depth of 8.3 ft bgs to 23 feet bgs. No visual impacts were observed on top of bedrock.

2.3.2 Former Tar Centrifuge House

A six-inch thick concrete foundation of the former Tar Centrifuge House was observed within test pit TP17-100 at a depth of 5 feet bgs. The materials within the foundation included fill material, sand, and concrete and brick debris. Stained soils were observed below the structure foundation from 6 feet bgs to 10 feet bgs. NAPL was not observed.

2.3.3 Former Oil and Tar Tanks

Test pit TP100-101 was excavated within the footprint of the various former oil and tar tank structures in an east west alignment. Multiple layers of concrete foundations, concrete sidewalls, and brick sidewalls were observed within the test pit. Materials observed within these structures included fill material, sand, concrete and brick debris, and piping. NAPL was not observed within these structures. Black stained soils with oil and tar like odors were detected in soils below the foundations. Slight oil like material and staining were observed in soils removed from top of bedrock.

2.4 Barrier/Bulkhead Wall Test Pit Investigation

As shown in Figure 2-2, one test pit (TP17-103) was excavated by ATL along the western site boundary, at an angle to the barrier/bulkhead wall alignment in an effort to determine the subsurface features and obstructions. The test pit excavation was stopped at 4 ft bgs due to water infiltration. Concrete, brick, and timber debris were observed within the top three feet of the test pit.

2.5 Sediment Investigation

As shown in Figure 2-3, seven vibrocore borings were advanced to approximate depths of 12-inches at 25-foot intervals along the proposed western and northern perimeter of the southernmost dredge area to delineate the perimeter of MGP-related impacts. Continuous core samples were acquired from sediment surface to the total depth of the boring and were field screened with a PID and visually described for textural compositions according to the Unified Soil Classification System and soil logging. No visual NAPL or MGP-like odors were observed in any of the samples. No VOCs were detected by the PID.

The sediment dredge prism is extended to these clean locations as shown in Figure 2-3.

2.6 Dewatering Bench Scale Study

Vibrocore samples were collected from multiple locations within the dredge area to conduct the dewatering bench scale study. The dewatering bench scale study was completed to determine the most efficient dewatering rate to be monitored during implementation of the remedy as well as evaluate the feasibility of using geotubes to remove suspended solids from the sediment decant water prior to physical and chemical treatment and discharge.

A varying combination and volume of polymers were tested during the bench scale study to determine the optimum mix. In addition, the bench scale study confirmed that geotubes will provide an additional benefit as a pretreatment step for the decant water.

2.7 Disposal Facility Pre-Characterization Borings and Sample Collections

2.7.1 Landside Excavation

Within the current site boundary, a total of 10 pre-characterization soil borings were completed using hand auger by an AECOM geologist. A total of 10 grab and composite samples for analytical analysis were collected from the pre-characterization boring locations. Two to three pre-characterization borings were advanced in each excavation area.

A soil sample was generated for each excavation area by homogenizing all of the soil from the borings within a given excavation area and placing the homogenized soil in laboratory supplied glassware. Samples were kept at 4°C and sent under chain-of-custody protocol via courier to Test America in Edison, New Jersey. Samples were analyzed for VOCs, semi-volatile organic compounds (SVOCs), total petroleum hydrocarbons (TPH), toxicity, polychlorinated biphenyls (PCBs), British Thermal Unit (BTU) content, ignitability, corrosivity, reactivity, cyanide, pH, moisture, sulfur, Toxicity Characteristic Leaching Procedure (TCLP) (inclusive of VOCs, SVOCs, metals, pesticides, and herbicides), metals, mercury, and hexavalent chromium. All pre-characterization boreholes were backfilled with bentonite pellets upon completion. All soils generated from pre-characterization drilling were containerized in 55 gallon drums and disposed at an approved off-site facility.

2.7.2 Sediment Dredging

Within the current sediment dredge prism boundary, a total of 47 pre-characterization sediment borings were completed using vibrocore methods. A total of 230 grab and/or composite samples for analytical analysis were collected from the pre-characterization boring locations. Multiple pre-characterization borings were advanced in each dredge prism. Sediment borings were completed to a depth ranging from 1-15 feet bgs, corresponding with either the bottom of the dredge limits or until no further visible impacts were observed.

All borings were completed by ATL with a barge-mounted vibrocore rig under the supervision of an AECOM geologist or environmental scientist. Sediments were logged for composition, visible and olfactory impacts, and field screened with a PID for VOCs. A summary of the observation collected during the sediment precharacterization work is provided in Appendix C.

A sediment sample was generated for each dredge prism by homogenizing all of the sediment from the borings within a given prism and placing the homogenized sediment in laboratory supplied glassware. Samples were kept at 4°C and sent under chain-of-custody protocol via courier to Test America, Inc. in Edison, New Jersey. Samples were analyzed for VOCs, SVOCs, TPH, toxicity, PCBs, BTU content, ignitability, corrosivity, reactivity, cyanide, pH, moisture, sulfur, TCLP (inclusive of VOCs, SVOCs, metals, pesticides, and herbicides), metals, mercury, and hexavalent chromium. All pre-characterization boreholes were backfilled with bentonite pellets upon completion. All sediments generated from pre-characterization drilling were containerized in 55 gallon drums and will be disposed at an approved off-site facility. A figure of the pre-characterization sediment boring locations is shown in Figure 2-4.

2.8 Utility Locate

Surveying of underwater utilities was completed by divers in December 2017. The survey of these utilities will allow the accurate determination of the extent of dredging and utility crossing cap areas. Locations of the surveyed utilities are presented in Figure 1-2B.

2.9 Bathymetric and Landside Survey

A licensed New York surveyor conducted a baseline survey of the extent of the landside remedy. In addition, the survey included other site elements such as site boundaries, topography, site features, bulkhead location and extent, storm drain and/or sanitary sewer system invert elevations, and other subsurface utilities (gas lines, etc.).

A bathymetric survey was completed for the purpose of developing a final dredge and cap plan, estimating debris quantities, and establishing a basis of payment. The bathymetric survey program was completed using multi-beam and side-scan sonar technologies to create a full-coverage map of the entire in-river work area, to include both riverbed elevation (contour) information and identification of submerged debris or other surface features that may interfere with dredging or capping.

Figure 2-5 presents the side scan and bathymetric survey. The sidescan report is included as Appendix F.

2.10 Air Monitoring

Ambient air quality and dust concentrations were monitored upwind and downwind of activities during all ground intrusive operations in accordance with the methods outlined in DER-10. Data was collected using PIDs and aerosol monitors. Real time readings were recorded by AECOM personnel in 15 minute intervals and logged continuously by the apparatus to monitor for VOCs and aerosols. Minor exceedances of the pre-determined action limits set for the site of 1 part per million (ppm) above ambient background levels for VOCs were noted and no exceedance of the action level of 100 micrograms per cubic meter ($\mu\text{g}/\text{m}^3$) above ambient background for aerosols was noted. Any noted exceedances in the VOC data were caused by factors other than PDI activities, including humidity and traffic emissions. Logged data has been reviewed and is provided in Appendix G.

2.11 Biological Assessment and Essential Fish Habitat Analysis

Biological assessment and essential fish habitat (EFH) analysis was completed by AECOM to support the United States Army Corps of Engineers (USACE) Nationwide Permit (NWP) #38 application. As part of the coastal zone consistency determination, a Habitat Impairment Test was also completed. Multiple field events were completed in December 2017 to provide field data related to the above analysis, assessments, and/or tests including:

- a site investigation was performed by an AECOM ecologist on December 11, 2017 who is also a certified arborist; and

- sediment and benthic invertebrate sampling to identify benthic invertebrates was conducted in the project area. Benthic samples were obtained through the use of a Van Veen Grab sampler to collect sediments from the river bottom. The grab sample was then brought to the surface and the sediments were washed away over a screen table. The remaining contents were then placed in a container with a preservative and biological stain. Later, the remaining materials were examined with a microscope and all species were identified to the lowest possible taxon. Nine mid-stream, three shoreline and two reference locations were sampled.

Copies of the EFH analysis and biological assessment are provided in Appendix H. The EHS analysis concluded that based on the available habitat within the remediation area in comparison to the habitat requirements of the listed species, it is anticipated that the Atlantic and shortnose sturgeon will likely utilize this habitat during a portion of their lifespan. Shortnose sturgeon has been documented in the river from the New York Harbor to the Troy Dam. From late fall to early spring, adult shortnose sturgeon concentrate in a few overwintering areas. Spawning adults concentrate just north of Kingston (River Mile [RM] 94) and non-spawning adults concentrate near Kingston and Haverstraw Bay. When water temperatures reach 8° C, typically in mid-April, reproductively active adults begin their migration upstream to the spawning grounds that extend from Troy to Coxsackie (RMs 149 to 118). Spawning typically occurs until water temperatures reach 15° C (generally from late April through May), after which adults disperse quickly downriver into their summer range. The broad summer range occupied by adult shortnose sturgeon extends from approximately RM 24 to RM 110. Similar to non-spawning adults, most juveniles are distributed throughout the mid-river regions during the summer from approximately RM 24 to RM 91 and move back into the Haverstraw Bay region during the late fall. Recent information suggests that shortnose sturgeons are using the Lower Hudson River below RM 9, at least during the November to April time frame (National Oceanic and Atmospheric Administration, 2008b).

Based on the shortnose and Atlantic sturgeon life cycles, with regard to spawning habitat and overwintering areas, it was concluded that given the size of the remediation area relative to the overall habitat (less than 1%) and timing of the proposed activities, potential disruption to the shortnose and Atlantic sturgeon appears to be insignificant.

The biological assessment concluded that the remedial action may affect, but is unlikely to adversely affect, the shortnose sturgeon or any distinct population segments of Atlantic sturgeon. Sediment disturbance, temporary increases in turbidity and associated water quality degradation, sediment redeposition, noise and vibration, vessel strikes, and accidental releases of hazardous materials are not expected to have significant effects on shortnose sturgeon and Atlantic sturgeon. Conservation measures such as establishment of construction windows to avoid seasonal periods where sensitive species are using these portions of the rivers would avoid, or minimize to insignificant levels, adverse effects on federally listed sturgeon species. In addition, based upon the data provided in the Greater Atlantic Regional Fisheries Office (GARFO) Master Species Table for Atlantic sturgeon, the proposed dredging and capping project may affect, but is not likely to adversely affect designated Atlantic sturgeon critical habitat in the river.

3. Remedial Design and Remedial Action Work Plan

This section describes the remedial goals and provides details of the remedial design that will be completed in order to satisfy the remedial objectives. For purposes of further discussion in this Work Plan, the term Site will include the former CHGE North Water Street MGP Site as well as the portion of Hudson River where remedial activities will take place consistent with the Decision Document [NYSDEC, 2016].

3.1 Remedial Goals

The remedial goals for the Site have been established through the remedy selection process stated in 6 NYCRR Part 375-1.10. As stated in the Decision Document, "At a minimum, the remedy selected must eliminate or mitigate all significant threats to public health and/or the environment presented by the contamination identified at the site through the proper application of scientific and engineering principles" [NYSDEC, 2016].

In accordance with the Decision Document, the remediation goals for this Site are to eliminate or reduce to the extent practicable:

- exposures of persons at or around the Site to Site contaminants in surface soil, subsurface soil, and groundwater;
- environmental exposures of flora or fauna to Site contaminants in surface soil, subsurface soil, and groundwater; and
- the migration of contaminants from surface soil and subsurface soil into sediment and surface water.

To achieve the remedial goals, a remedial design has been developed in accordance with the Decision Document and BCA. A summary of the design basis and remedial action to be implemented in accordance with the remedial design is presented below.

3.2 Mobilization and Site Preparation

Mobilization activities will include obtaining required permits; Site preparation; transportation and staging of steel sheet piles to the Site, arranging for waste transportation; arranging for utility hook-ups (as needed); mobilizing field offices, constructing temporary water collection and treatment facilities, staging necessary equipment and personnel; preparing a project specific HASP and holding an on-Site health and safety training session; mobilizing barges and boats; establishing navigational routes; installing temporary project support facilities, constructing temporary staging areas and installing an on-Site decontamination facility. Figures 3-1, 3-2, and 3-3 present the Site control activities that will be implemented during the different phases of the remedial activities.

3.2.1 Site Preparation

The Site will be prepared for implementation of the remedial action work. The Site preparation activities include: installation of an alternate Site access road; installation of erosion and sedimentation controls; installation of temporary site facilities; surveying to establish baseline conditions and grades; utility location, protection, and relocation, as necessary; debris removal; installation of turbidity controls; and installation of traffic controls at the Site. Any monitoring wells that will be damaged during the remedy implementation will be cut at the excavation bottom and grouted or abandoned per NYSDEC regulations during the Site preparation activities. Documentation required for the abandonment and removal of these wells will be included in the FER.

All necessary engineering controls to control odors, dust, and turbidity will be installed prior to the start of remediation activities.

3.2.2 Alternate Site Access Road

Construction of an alternate access road from Dutchess Avenue to the Site will take place prior to the barrier/bulkhead wall work. The access road will replace the existing access road along the western portion of the Site to facilitate wall installation. Figures 3-1 and 3-2 present the layout and details of the alternate Site access road.

3.2.3 Erosion and Sediment Controls

Erosion and sediment controls, including silt fences, will be installed prior to any disruption of Site soil, in accordance with local, state, and federal regulations. The erosion and sediment controls will be maintained throughout the duration of the work. Figures 3-1, 3-2, and 3-3 present details of the erosion and sediment controls proposed for the RA. Additional details are presented in Section 3.2.3.

3.2.4 Turbidity Curtains

Deployment of turbidity curtains will take place prior to any in-water work in accordance with Best Management Practices (BMPs). Details are presented in Sections 3.6.1 and 5.2.1 and shown in Figures 3-1, 3-3, 3-4 and 3-5.

3.2.5 Site Facilities

Site facilities will be installed as needed to support and execute the work. The following Site facilities will be needed during remedial construction:

- construction offices;
- utilities (electric, water, sewer, and telephone);
- lighting;
- fuel storage and dispensing;
- sanitary facilities;
- decontamination pad(s);
- health and safety equipment;
- material laydown areas;
- soil stockpile areas;
- docking areas;
- water treatment plant laydown areas;
- land and marine traffic control signage; and
- parking areas.

Work zones will be established within the Site boundaries in accordance with the site-specific HASP and Site control areas that define the initial Exclusion Zones, the Decontamination Zones, and the Support Zone. These zones will change as the work progresses in order to maintain safety and allow for practical completion of the work.

3.2.6 Surveying

A New York State-licensed surveyor has determined the initial benchmarks and stakeout for horizontal and vertical dredge or excavation limits and the barrier /bulkhead wall. This initial survey will be used to confirm and maintain horizontal and vertical limits as the work proceeds. The licensed surveyor will return to the Site as needed to document wall extent, actual excavation work limits, measurement of unit cost bid items, and to complete an as-built survey of the finished work.

3.2.7 Utility Protection

Utilities that are active will be protected or relocated during implementation of the excavation, barrier/bulkhead wall installation, and in-river remedies. These utilities include sanitary and storm sewers, underground and underwater gas lines, gas meter pits, water, telephone, underwater fiber optic lines, and underwater and overhead power lines. Utility clearance for all work at the Site will be conducted prior to start of any intrusive work.

3.2.8 Marine and Land Traffic Management

A Transportation Plan will be prepared for the Site that describes the procedures that will be followed to manage construction traffic during the work in a manner that minimizes disturbance to the community. Specific off-Site transportation routes will be developed in consultation with local municipality, coast guard, and emergency departments. As the dredging will take place in the river and dewatered sediment from the dredging activities will be transported via barge for off-Site amendment and disposal at a barge bulk loading facility in Jersey City, New Jersey, boat traffic management is also addressed in the Transportation Plan. The Transportation Plan will be submitted to the NYSDEC for information purposes prior to the commencement of remedial activities.

3.3 Landside Remedy (Phase I)

Upland excavation will begin following utility relocation and site clearing and grading. The RA includes removal of surface soils (0 to 2 feet bgs) within areas delineated by the Decision Document (NYSDEC, 2016) to prevent or reduce the potential for human exposure to soils that exceed background and industrial use Soil Cleanup Objectives (SCOs); placement of certified clean fill in excavated areas; placement of site-wide cover system; and implementation of institutional controls and SMP.

The limit of excavation is shown in Figure 3-6. The excavation will extend down up to a depth of 1 to 2 feet bgs representing a total in-place volume of approximately 3,400 cubic yards (cy). The water table is shallow ranging from 6 to 18 inches bgs in the lower level of the site and deeper at approximately 10 to 15 feet bgs on the upper level. No dewatering is anticipated for this excavation.

Subsurface concrete foundations of former MGP structures, cable, pipe, brick, and other debris may be encountered within the excavation limits. These materials will be broken up with an excavator bucket or a hoe ram device if needed, segregated from the soil, stockpiled, and shipped offsite for disposal as described in Section 3.10. Soils will be excavated with standard track-mounted equipment. Other common engineering controls, including foam application, small excavation areas, etc. will be used to control the release of vapors and dust. Sequencing of excavation work will be selected to maximize production rate. Targeted material will be excavated and direct-loaded to trucks for transport off-site to a CHGE-approved disposal facility.

To the extent feasible, excavated material will be direct loaded into trucks for off-site disposal. Management of soil within the stockpile area is described in Section 3.10.

3.4 Barrier/Bulkhead Wall Installation (Phase II)

Installation of the barrier/bulkhead wall will begin following landside excavation and completion of the temporary access road. A vertical subsurface barrier/bulkhead wall will be installed to prevent migration of NAPL from the upland portion of the Site to the river and stabilize the shoreline as shown in Figure 3-7. Installation of the barrier/bulkhead wall includes:

- installation of 490 feet of cantilever steel sheet pile combination barrier/bulkhead wall to depth of 50 feet bgs or bedrock whichever is encountered first with the following modifications to meet the requirements of a NAPL barrier:
 - interlocks between the sheet pile pairs will be welded; and
 - interlocks between two welded sheet pile pairs will be sealed using a NYSDEC approved sealant (i.e., adeka, deneef or similar);
- installation of 226 feet of cantilever steel sheet pile bulkhead to various depths to stabilize the shoreline;
- completion of the top of barrier/bulkhead wall to the mean low tide water elevation, to the extent practicable (with the exception of bulkhead wall in the vicinity of the CHGE electric transmission transition station where the top of piles will be completed at elevation 5 feet above NAVD88); and
- restoration of barrier/bulkhead wall alignment by placement of riprap and landscaping.

In concurrence with NYSDEC recommendations, the vertical surface of the barrier/bulkhead wall visible above the river water level will be eliminated as much as possible. With the exception of the southernmost portion of the wall, this will be accomplished by cutting the sheets to the mean low tide elevation (effectively lowering the top of wall elevation to mean low tide elevation) and/or placement of riprap over and above the exposed wall surface. The purpose of the southernmost portion of the barrier/bulkhead wall (starting from the southern extent of the wall to 65-feet north) is to provide storm hardening/stability to the existing critical electric infrastructure (transition station). The current elevation around the transition station is 5 feet above NAVD 88. Thus, to achieve a sufficient level of storm hardening/stability, the southern portion of the wall must be maintained at its' current elevation of 5 feet above NAVD 88, though the top of wall elevation will gradually grade down to meet the overall wall elevation approximately 65 feet north of the southern end of the wall alignment. In addition, rip-rap will be placed in and around the bulkhead wall to provide erosion protection.

Based on existing data, the barrier/bulkhead wall is anticipated to have minimal effect on groundwater elevations in the vicinity of the Site. An increase in groundwater elevation at the upgradient side of the wall over a wide range of hydraulic conductivity is estimated to be negligible.

The northern portion of the barrier/bulkhead wall is anticipated to be installed from the land. The southern portion of the bulkhead wall, extending from south of the centerline of the Walkway Over the Hudson (WOTH) bridge to the existing steel bulkhead over the electric utility crossing, will be installed via a barge mounted crane. The sequence for installation is expected to progress from south to north.

Pre-trenching to a depth of three feet bgs along the barrier/bulkhead wall alignment will take place to remove subsurface debris and obstructions. It is anticipated that visibly clean fill from pre-trenching activities may be placed back into the excavation while debris and grossly impacted soils will be shipped off-Site for disposal.

A variable moment vibratory hammer will be used to install the sheets to specified depths, varying in relation to the top of bedrock or maximum of 50 feet bgs along the replacement bulkhead alignment. Sheets are expected to be installed over the 716-foot length of the replacement bulkhead wall, with depths of individual sheets ranging from approximately 20 to 55 feet. Figure 3-7 presents the extent of the barrier/bulkhead wall while Figure 3-8 presents the wall profile.

A double row of permeable turbidity curtains designed and installed consistent with USACE Silt Curtains Dredging Project Management Practice Guidance Document ERDC TN-DOER-E21 (USACE, 2005) and New York Standards and Specifications for Erosion and Sediment Control (NYSDEC, 2005) is anticipated during the installation of the barrier/bulkhead wall as shown in Figure 3-1. Final silt/turbidity design, deployment, and maintenance will be conducted in accordance with the checklist provided in ERDC TN-DOER-E21. The curtain design and deployment will be continually modified and upgraded as required to achieve the required water quality goals. Given the tides, water velocity, and in some sections water depth, the design, installation, and maintenance of the curtains will be carefully controlled. Typically, the final design and deployment details of the turbidity curtains evolve and are optimized as the project proceeds. Due to the water velocities, the curtains will include water permeable sections. Curtains that reach the river bottom may or may not be more effective compared to curtains that remain a foot or more above the sediment bottom.

In addition to the turbidity curtains, the AECOM Site Engineer will periodically (at a minimum 15-minutes frequency) check the river in the vicinity of the remedial activity for the presence of turbidity or sheens.

Corrective measures for observation of turbidity beyond the silt curtains may include:

- inspection, repair, or relocation of turbidity controls
- slowing or suspending work until current or wind conditions improve
- changes in pile driving process (slower driving speed etc.)
- changes in backfill placement rate or method
- other means as required to reduce turbidity to suitable levels

Corrective measures for observation of sheen beyond the silt curtains may include:

- placement of sheen controls e.g., buoys fitted with booms around the specific work area

- isolation of sheen and removal via use of oil absorbent booms
- creation of a barrier (e.g., ditch) if feasible

3.5 River Slope Regrading (Phase III)

River slope regrading will take place following the installation of the barrier/bulkhead wall. Figure 3-9 shows the area requiring regrading. The slope of the shoreline along the site cannot be dredged to remove potentially impacted soils remaining between the bulkhead wall and the dredge area due to the riverbank stability concerns. In these areas, NAPL containment will be provided through capping. Regrading of the river bank slope is necessary to:

- allow installation of the barrier/bulkhead wall;
- minimize the exposed surface of the barrier/bulkhead wall; and
- provide long-term stability of the cap system.

River slope regrading activities will include:

- regrading of approximately 1.22 acre area of the river slope as shown in Figure 3-9 to establish an even grade;
- removal of debris within the cap installation area;
- establishing a 2Horizontal:1Vertical river bank slope by
 - removal of approximately 1,722 cy of river slope; and
 - placement of approximately 6,775 cy of imported certified clean material and/or reuse visually clean removed river slope material
- reuse of visual and olfactory clean slope material under the river slope cap;
- off-site transportation of visual and olfactory impacted river slope material to off-site disposal facility; and
- placement of river slope stone toe cap if required.

The regrading will take place from two separate locations. Initially the top two thirds of the river slope area will be regraded from the land using long stick excavators. The bottom one-third area will then be dredged and regraded using barge based equipment.

Figures 3-9, 3-10A, and 3-10B provide plan and cross-sectional views of the proposed river slope grading activities.

A double row of permeable turbidity curtains designed and installed consistent with USACE Silt Curtains Dredging Project Management Practice Guidance Document ERDC TN-DOER-E21 (USACE, 2005) and New York Standards and Specifications for Erosion and Sediment Control (NYSDEC, 2005) is anticipated during the regrading of the top portions of the river slope which will be conducted from land as shown in Figure 3-3. Final silt/turbidity design, deployment, and maintenance will be conducted in accordance with the checklist provided in ERDC TN-DOER-E21. The curtain design and deployment will be continually modified and upgraded as required to achieve the required water quality goals. Given the tides, water velocity, and in some sections water depth, the design, installation, and maintenance of the curtains will be carefully controlled. Typically, the final design and deployment details of the turbidity curtains evolve and are optimized as the project proceeds. Due to the water velocities, the curtains will include water permeable sections. Curtains that reach the river bottom may or may not be more effective compared to curtains that remain a foot or more above the sediment bottom.

In addition to the turbidity curtains, the AECOM Site Engineer will periodically (at a minimum 15-minutes frequency) check the river in the vicinity of the remedial activity for the presence of turbidity or sheens.

Corrective measures for observation of turbidity beyond the silt curtains may include:

- inspection, repair, or relocation of turbidity controls
- slowing or suspending work until current or wind conditions improve

- changes in regrading process (slower slope material removal etc.)
- changes in backfill placement rate or method
- other means as required to reduce turbidity to suitable levels

Corrective measures for observation of sheen beyond the silt curtains may include:

- placement of sheen controls e.g., buoys fitted with booms around the specific work area
- isolation of sheen and removal via use of oil absorbent booms
- creation of a barrier (e.g., ditch) if feasible

3.6 In-River Dredging and Restoration (Phase III)

Dredging will be conducted within the areas depicted on the Figure 3-11 as delineated by the Decision Document and PDI to remove NAPL-impacted sediments. The figure also depicts vertical extent of the dredging below the current sediment surface to meet the remedial objective of removing NAPL-impacted sediments. The proposed dredge sections are depicted on Figure 3-12.

The in-river dredging and restoration activities will take place following completion of the river slope regrading activities and will include:

- removal via dredging and off-site disposal of visually impacted sediments in the river as delineated by the Decision Document (NYSDEC, 2016) and PDI;
- on-site management of dredge sediments including sediment dewatering;
- on-site treatment of sediment decant water and discharge to the river;
- off-site transportation, stabilization, and disposal of approximately 40,000 cy of impacted sediments via barge; and
- placement, via tremi pipe mechanism, of approximately 40,000 cy of imported certified and NYSDEC approved clean fill within dredge areas to pre-construction sediment surface.

Targeted river sediments will be dredged using approximately 14-cy environmental bucket, which is designed to provide flat dredge cuts for maximum control of the dredged surface. In addition, it utilizes seals to limit loss of material as the bucket is raised through the water column. All dredging will take place within a containment cell mounted to the dredge barge. The containment cell will be outfitted with turbidity curtains and floating booms on all sides to control transport of contaminated sediments and NAPL, released during dredging, outside the work area. Water quality (turbidity) will be monitored for the duration of the dredging as described in Section 5.2.1.

Full scows will be transported to an on-site mooring for dewatering, where excess water will be transferred to a decant barge. Following dewatering, the material scows will be transported to an approved treatment and/or disposal facility for off-site stabilization, treatment, and disposal of dredged sediments. Tentative disposal facilities include Clean Earth of New Jersey located in Kearny, New Jersey, Bayshore Recycling located in Keasbey, New Jersey, and ESMI of New York located in Fort Edward, New York.

Based on the NYSDEC Decision Document, visual confirmation and documentation will be performed to confirm the excavation endpoint. The on-site resident engineer will note the dredge buckets removing sediments from dredge prism sidewalls and bottom for presence of visible NAPL. The dredge prism will be expanded if NAPL is observed (within the sediments removed from the bottom and sidewall) or considered complete when design depths have been achieved. Depth confirmations will be provided via a GPS system installed on the dredge barge, with a land based total system.

3.6.1 Best Management Practices

BMPs and engineering controls will be employed during dredging operations to limit impact to the river including:

- **Environmental Bucket:** Targeted river sediments will be dredged using an environmental bucket, which is designed to provide flat dredge cuts for maximum control of the dredged surface while also utilizing seals to limit loss of material as the bucket is raised through the water column.
- **Containment Cells:** Water-based (re-suspension) control measures will be installed prior to performing any intrusive activities in the river (e.g., debris removal, dredging). All dredging will take place within a containment cell mounted to the dredge barge as shown in Figure 3-4. The containment cell will be outfitted with turbidity curtains and floating booms on all sides to control transport of contaminated sediments and NAPL, released during dredging, outside the work area. This innovative system ensures containment of dredge activity on all sides providing a comprehensive control system. The turbidity curtain will be weighted down with the galvanized steel chain ballast and will extend to the bottom of the river to contain all dredge area sediments within the containment cell. The bottom 10 feet of the turbidity curtain will have an impermeable polyvinyl chloride (PVC) coating to minimize escape of sediments out of the containment cell and the top 10 feet of the curtain will also have an impermeable PVC coating to minimize escape of sheen out of the containment cell. The middle portion of the turbidity curtain will be constructed of woven fabric to allow flow of water while minimizing transfer of sediments. Figure 3-5 provides details of the containment cell. The containment assembly will be lifted slightly and moved to the next dredge location upon completion of dredging in one area. Frequent and periodic inspection and maintenance of the containment cell will take place during the duration of the sediment dredging activities.
- **Work Area Surface Water Monitoring:** Visual surface water monitoring will occur throughout the dredging and backfilling operation by an AECOM personnel present on the dredge barge. The AECOM personnel will provide visual confirmation of turbidity as well as presence of any sheen beyond the containment cell.
- **Downstream Surface Water Monitoring:** A patrol boat, equipped with oil absorbent and containment booms, will be available downstream of the work area to visually inspect the surface water and mitigate any sheens observed. Figure 3-3 shows the location of water quality monitoring.
- **Turbidity Monitoring:** A turbidity monitoring program will be performed during the sediment removal and backfilling activities. Water quality (turbidity) will be monitored for the duration of the dredging by means of three buoy-mounted remote sensing stations that will be moored around the perimeter of the work area to confirm that the containment cell is functioning properly. Turbidity will be measured at an upstream location, near the work zone, and two downstream locations. Figure 3-3 shows the location of water quality monitoring activities.
- **Inspections:** Inspections, performed by AECOM and it's subcontractor, of the water-based controls will be conducted each day at the beginning of intrusive activities. Inspections will also be conducted, as appropriate, in response to visible sediment plumes migrating from the work area or measured turbidity levels above the action level of 50 nephelometric turbidity units (NTUs) above the turbidity level at the upstream monitoring location. Inspections in response to turbidity levels above the action level metric will begin by re-sampling the downstream location to determine if the prior result was an anomaly or if the elevated reading was a result of a short duration event. If the exceedance is not an anomaly then contingency measures will be implemented. Section 5.2.3 identifies contingency measures to meet turbidity action levels. Contingency measures will include at a minimum:
 - surface inspection (e.g., by boat) to determine condition of dredging containment system and address (e.g., repair) noted deficiencies;
 - if the cause of the turbidity exceedance cannot be determined through surface inspection (i.e., no visible damage, breach, tear, or dislocation), a hand-held turbidity meter or other appropriate method will be used to further investigate the cause of the turbidity increase; and
 - evaluation and modification to dredge operations (e.g. fall height, cycle time, bucket handling procedures, use of a rinse tank, etc.) or modifications of the containment cell.

3.7 Reactive Core Mat River Slope Capping (Phase III)

The river slope cap will be installed following dredging activities. The area of river slope cap is presented in Figure 3-13. Prevention of NAPL migration from the river slope area will take place by placement of reactive core mats (RCM) overlain by articulated block mattress on the river slope. The cap will be constructed using the articulated block

mattress attached to organoclay RCMs, assembled on land in large segments and then placed on the slope. Placement of a rip-rap layer over the river slope cap will take place, as recommended by the NYSDEC, to provide habitat enhancement. Further details of the rip-rap layer are presented in Section 3.21.3, while Section 3.12.4 provides further details on the habitat restoration/enhancement provided by the cap. Cross-sections of the river slope cap are presented in Figure 3-14.

3.8 Reactive Core Mat Utility Capping (Phase III)

At two separate Utility Crossing areas, dredging of sediment is not feasible due to the need to protect the utility lines. In lieu of removal of impacted material in these areas, approximately one acre of area near and over the utility crossings (Figure 3-13) will be capped with a cover system consisting of RCM overlain by premanufactured armored concrete blocks to isolate the impacted sediment in these areas.

Similar to the river slope cap slope, these assemblies will be largely constructed on land and then placed in large segments, limiting the quantity of subaqueous work required for installation. The RCM provides control of residual NAPL migration beneath the cap, while the armor mats protect the utility from damage. Based on visual observation, approximately one (1) to two (2) feet of clean fill will be placed over the utility line. Section 3.12.3 provides further details on the habitat restoration/enhancement provided by the cap. Figure 3-15 presents details of the components of the proposed cap.

3.9 Decontamination

During and upon completion of the excavation phase of the project, decontamination of equipment will be performed in order to prevent contaminated material from being spread offsite during waste hauling activities and to prevent the spreading of impacted material to un-impacted areas of the site. A truck wash decontamination pad will be constructed as shown in Figure 3-2. Trucks used for transport of excavated material will be decontaminated using dry decontamination methods (*i.e.*, removal of loose material with a broom or brush) to limit the volume of decontamination water, which will require treatment and disposal. These methods, along with parking of trucks on plastic sheeting during loading, will effectively prevent the spread of contaminated materials onto roadways during transport to disposal facilities. Decontamination of the earth-moving equipment will occur at the completion of the excavation phase and prior to the handling of clean backfill or mobilization offsite. The method of equipment decontamination will consist of pressure washing to remove any impacted soil. Decontamination water generated during cleaning of tools and equipment will be collected and transferred to the water treatment system. Water generated from decontaminating personnel will be minimal due to the availability of disposable personal protective equipment (PPE) such as Tyvek coveralls, booties, and nitrile gloves. The volume of decontamination water is assumed to be negligible compared to flow rates for dewatering and stormwater removal in the disturbed areas of the site.

3.10 Solid Waste Management

3.10.1 On-Site Waste Management

To the extent possible, wastes generated during upland excavation will be loaded directly into trucks for off-site transportation. Generally, however, excavated soil may be transported by loader or on-site haul truck from the excavation areas to a designated temporary stockpile area. Berms and liners will be used to protect underlying materials from becoming impacted.

On-site storage will take place in accordance with all laws and regulations dealing with the type of waste being stored. Liquid wastes will be stored in appropriate tanks or drums. Other (non-soil) solid materials will be stored in roll-off containers or covered/lined stockpiles.

Debris generated during site clearing, excavation, and pre-trenching may require decontamination and/or crushing to meet facility acceptance requirements. Decontamination will be performed using brushes, steam cleaners, and/or pressure washers. Residues from decontamination operations will be collected and managed with impacted soils. Excavation debris that can be properly decontaminated will be sent to an off-site facility for disposal. Decontamination water, as well as residuals from dewatering activities will be temporarily stored in appropriate tanks prior to treatment

and management in the temporary water treatment system or transported to an appropriate off-site disposal facility as required.

Soils not meeting TCLP requirements will be shipped to a thermal treatment facility permitted to accept such soils under the New York State conditional exclusion for soils exhibiting the toxicity characteristic for benzene (D018). If the soils are shipped out of state, the handling and disposal of the soil will be in compliance with the regulations of the receiving state.

Soils that must be excavated wet, such as following a heavy storm event or if heavy infiltration of water in the excavation hole is observed, will be staged to remove excess moisture. Soils that are too wet for shipment (greater than approximately 20% moisture content) will be amended with a drying agent (fly ash or equivalent) or staged onsite to allow the moisture content to be reduced to < 20% through draining or evaporation.

Dredged sediments will be transferred directly from the dredge bucket to a barge as described in Section 3.10.3.

3.10.2 Waste Characterization

All wastes at the Site that have been impacted by MGP residues will be classified as non-hazardous industrial waste unless they are determined to exhibit the characteristics of ignitability, corrosivity, reactivity, or TCLP lead, as determined by laboratory testing. If they do exhibit one or more of these characteristics, they will be classified as hazardous wastes.

The soils within the excavation and sediment within the dredge area have been pre-characterized. Pre-characterization will facilitate the profiling and pre-acceptance of the materials to the disposal facilities.

3.10.3 Off-Site Transportation

Excavated grossly impacted materials will be transported in dump trucks to the receiving facilities. Transportation of grossly impacted materials from the Site will be performed in accordance with all applicable waste and transportation regulatory requirements and in accordance with a Transportation Plan.

All haul trucks will be permitted waste transporters in the State of New York and have poly bed liners and 6-mil poly covers. In addition, if there is the potential for liquids or tarry material leaking from the waste, they will be required to have gasketed tailgates. All material transport trucks will be sprayed, as necessary, with odor suppressive foam or BioSolve prior to covering to reduce vapor and odor emissions. Trucks will be loaded in such a way as to avoid contamination of their exteriors, including tires. In the case when truck exteriors do become contaminated, they will be decontaminated prior to leaving the site. All trucks will be checked before leaving the site and all loose soil or other materials will be brushed and/or washed off to prevent spreading to streets or other areas off-site.

Waste shipments will be documented using standard waste manifests as required by applicable hazardous waste regulations. Other waste materials that have no specific documentation requirements will be documented using waste tracking forms, bills of lading, and receipts. All shipments of waste from the Site will be documented, describing the type and amount of waste and the receiving facility.

Dredged sediments will be transferred directly from the dredge bucket to a barge. Full scows will be transported to an on-site mooring for dewatering, where excess water will be transferred to a decant barge. Once sufficiently dewatered, full scows will be transported off-site for stabilization and thermal treatment of dredged sediment. All barges will be checked for overflow and will be covered with 6-mil poly prior to leaving the Site.

3.10.4 Off-site Disposal or Treatment

Off-site disposal sites include landfills and thermal desorption facilities. Four facilities have been selected for the thermal desorption and disposal of impacted material from the Site. These include:

1. Environmental Soil Management Inc. of New York, located at 304 Tow Path Road, Fort Edward, NY 12828.
2. Bayshore Recycling, located at 75 Crows Mill Rd., Keasbey, NJ 08832.
3. Clean Earth of New Castle, Inc., Pyles Lane, New Castle, Delaware 19720.

4. Clean Earth of Southeast Pennsylvania, 7 Steel Road East, Morrisville, PA 19067.

These treatment facilities are suitable for the disposal of non-hazardous industrial waste and contaminated debris that has been crushed to appropriate size.

Debris which cannot be reduced to the appropriate size will be transported to an approved and licensed landfill disposal facility. Additional disposal facilities may be required for the treatment or recycling of NAPL if sufficient quantities are encountered in the excavations.

3.11 Water Management

Significant volumes of construction water will be generated during the dewatering activities conducted to support sediment dredging. Water containing MGP constituents will also be generated during decontamination of debris and equipment. Stormwater run-off from impacted areas will also be collected. The work, performed under a BCA, will meet the substantive requirements of a State Pollutant Discharge Elimination System (SPDES) discharge permit equivalent.

The water generated as a result of the remedial action will be treated to meet the limits established by NYSDEC for discharge from the Site. Following treatment, the water will be sampled and discharged in compliance with NYSDEC requirements. If no sampling requirements are detailed by NYSDEC, a minimum of one sampling event per week will be completed to document the effluent water. Disposal characterization samples will be submitted to a New York State certified laboratory for analysis required by NYSDEC.

The treated water will be discharged via surface pipe to the river. All the requirements specified by NYSDEC will be followed and documented in the FER along with a copy of the analytical testing completed pursuant to NYSDEC requirements.

All sediment, coal tar residue, or other solid materials/sludge generated by water management will either be collected in on-site drums and disposed of in accordance with applicable federal and state regulations or shipped with Site soils to an approved thermal treatment facility. At no time shall the addition of these materials allow the Site soils or sediments to be classified as hazardous waste or raise the moisture level to greater than 20%.

3.11.1 Water Treatment

A temporary water collection and treatment system will be constructed at the Site to manage construction related water generated during the sediment dredge activities. The treatment system will run continuously until the remediation project is complete. The treatment system will be designed to meet the limits stated by the NYSDEC. Based on the preliminary dewater bench test, it is anticipated that approximately 250 gallon per minute of construction water will be managed in the system. The collection and treatment system for treating MGP impacted construction water is comprised of the following major subsystems:

- decant barge;
- construction pit sump pump/vacuum pump dewatering pumps;
- influent modutank with geotubes;
- influent surge tanks;
- de-emulsifiers;
- pH adjustment tank;
- coagulant drums;
- caustic drums;
- coalescer/ clarifier tank;
- sand filter tanks;
- granulated activated carbon tanks; and

- effluent surge tanks.

A conceptual treatment process has been presented in Figure 3-16. As mentioned earlier, treated water for this project will ultimately be discharged to the river.

3.12 Site Restoration

3.12.1 Landside

Following excavation activities, the excavation will be backfilled with certified clean fill that meets NYSDEC 6 NYCRR Part 375 Subpart 6.7 (d), in 12-inch lifts and properly compacted. The backfill will be sampled at least once for each borrow source and the results will be submitted to the NYSDEC with the appropriate form for review and approval prior to shipment.

Following installation of the barrier/bulkhead wall, placement of approximately 0.1 acre of material will be required behind the newly constructed steel bulkhead to stabilize the shoreline. The material will consist of an armor layer imported from an offsite source. The armor layer will consist of 20-inch minus (d50 = 20 inch, minimum size = 6 inch) washed stone, river rock, gravel, and/or cobbles, containing no debris or organic material underlain by approximate 7-inch diameter stone underlayer. A demarcation layer will be placed prior to placement of any armor layer. Information regarding this material will be submitted to the NYSDEC with the appropriate form for review and approval prior to shipment. Figure 3-17 presents the preliminary site restoration plan while Figure 3-18 presents the cross section detailing the armor layer. The bank restoration plan also includes the vegetation types proposed for the restored river bank inboard of the wall and armor layer. The seed mix for the vegetative layer will include:

- Andropogon Gerardii
- Heliopsis Helianthoides
- Juncus Tenuis
- Monarda Fistulosa
- Sorghastrum Nutans

All disturbed areas shall be re-graded to match the surrounding areas. The entire excavation area will be restored with gravel similar to existing conditions. Utilities relocated during site preparation activities will be re-routed through original locations as deemed necessary.

3.12.2 River

Backfilling of dredge areas will take place with NYSDEC-approved and certified clean fill (approximately 40,000 cy) imported from off-site sources and transported to the Site via barge. The clean fill will be placed in the dredged areas to the pre-remediation bathymetric surface. Figure 3-19 shows the dredge restoration area while Figure 3-20 shows typical dredge and fill section details. The fill will consist of a granular material of sufficient size and density to match the surrounding non-disturbed sediments. Clean fill was selected specifically to maximize accuracy of the fill placement operation and minimize suspension and transport of backfill material outside of the intended placement location.

To minimize turbidity and allow accurate placement, the clean fill will be placed on approximately 4.2 acres of the dredged areas using a containment cell similar to that used during dredge operations (Figure 3-4).

3.12.3 River Slope Restoration

Placement of approximately 24-inch thick layer of rip-rap will take place over the cap to provide habitat restoration/mitigation. The rip-rap stone will range in size from 9 inch to 18 inches. Placement of the rip-rap layer may take place toward the end of remedial activities with other restoration activities. Figure 3-20 presents a sectional view of the river cap slope restoration.

3.12.4 Habitat Restoration and Enhancement

The completed restoration in dredge areas, rip-rap over the river slope, and concrete mats over the utility crossings areas) will provide ecological functions and values equal to or greater than current conditions.

A benthic habitat comprised of finer-grained sediments is somewhat common in the river. The placement of clean sand and removal of the toxins associated with NAPL would have long-term benefits to the marine community. In addition, the gradation of the sand will match, to the extent feasible, the gradation of the existing sediments.

Placement of the articulated block mattress would bury the existing benthic community (if present), including potential prey for Atlantic and shortnose sturgeon. Although individuals among the existing benthic communities might be impacted, installation of the concrete mats would not preclude the survival of benthic infaunal species and shellfish. Shortnose and Atlantic sturgeon would be able to use adjacent areas for foraging and other activities. The pre-fabricated cap combines the favorable aspects of lightweight blankets and meshes such as porosity, flexibility, vegetation encouragement, and habitat enhancement with no erodible self-weight and high tractive force resistance. The presence of these open cells could also provide habitat structure for fish and invertebrates, as well as micro-topography with potential for sediments to fill the voids and allow for colonization by a benthic community. Placement of the rip-rap over the river slope cap will provide a natural habitat for the establishment and growth of benthic community.

Benthic sampling conducted along the river slope and river bottom in 2017, identified that the benthic habitat is largely dominated by sediments with a limited assemblage of benthic invertebrates species. Review of NOAA Charts and other materials suggest much of the river bottom in this area of the Hudson is also dominated by fine- to moderate coarse-grained sediments. Installation of these materials could cause a permanent change in benthic habitat from soft sediments to the hard substrate of the concrete mats within the footprint of the concrete mats.

This will introduce habitat diversity through the inclusion of hard substrates resulting in topographic relief to the cap area, which would allow for sessile organism colonization. Concrete mats provide hard substrate habitat, and gaps in the mats provide velocity refuge and cover for aquatic invertebrates and small fishes (Fischenich, 2003), possibly including benthic prey for shortnose and Atlantic sturgeon. When the concrete mats are placed in areas of fine sediment, the spaces between the individual concrete elements would be filled by suspended sediment and the surficial habitat would be partially restored. It is likely that sediment will accumulate within the concrete mats, resulting in some benthic habitat re-colonization. New and functional communities would be expected to recolonize these areas over time. Moreover, the placement of these materials would increase the surface rugosity (three-dimensionality) of the benthic habitat, which would be utilized as a habitat resource by small demersal fish species (e.g., gobies, etc.), which, in turn, would serve as prey species for other marine fauna. Therefore, the removal of NAPL contamination, placement of rip-rap over the river slope, and addition of hard substrates in an area dominated by sediments should create a habitat complex that should provide a measure of ecological uplift to project area

3.12.5 Mitigation

Habitat loss and/or impact to fish habitat is expected to take place as a result of the remedial activities. As a result and in accordance with NYSDEC requirements, habitat mitigation measures will be implemented following the completion of the remedial activities. The objective of mitigation will be to improve water quality and/or enhance existing fish habitat. These alternatives may include:

- Financial support to the newly formed Hudson River Drinking Water Inter-Municipal Council (HRDWIC) to assist them in pursuing goals and initiatives intended to provide Source Water Protection;
- Debris removal in and/or along local tributaries; or
- Shoreline softening.

3.13 NAPL Collection (Phase IV)

NAPL collection activities will be implemented following Site restoration. Installation of passive NAPL collection wells at select locations will take place as follows:

- in the area north of the barrier/bulkhead wall, the natural gas pipeline enters the upland portion of the site and precludes the safe construction of the barrier/bulkhead wall. At this location, the NAPL collection wells will be completed in lieu of in-situ solidification to manage approximately 20 cy of deeper soils (approximately 30 feet bgs) required by the Decision Document. The presence of utilities and depth of impacts preclude safe and cost effective implementation of various solidification technologies. The NAPL collection wells along with extension of the utility crossings cap to the top of the surface surrounding the gas pipeline will achieve the remedial goals listed in the Decision Document. Installation of the NAPL collection wells will include:
 - two NAPL collection wells installed approximately 15 feet apart along the gas utility crossing;
 - directional drilling to minimize accidental impact to active gas lines and avoid disruption to gas operations;
 - Installation of stainless steel screen and sump material; and
 - One round of vacuum extraction, if necessary, to remove any accumulated NAPL in the subsurface.
- Installation of NAPL collection wells landward of the barrier/bulkhead wall to collect and remove mobile NAPL that may be present in the subsurface and/or migrating towards the barrier/bulkhead wall. The NAPL collection wells will be completed to top of bedrock and installed with stainless steel screen and stainless steel sump materials. The amount, construction, and locations of NAPL collection wells will be discussed with the NYSDEC prior to installation.

4. Permitting and Regulatory Requirements

4.1 Permitting

In addition to performance requirements established to ensure that the design of the remedial action meets the remedial action objectives established in the Decision Document, the design has been prepared to meet permitting and other regulatory requirements of local, state, and federal laws and regulations. Comprehensive research has been conducted to identify local, regional, state, and federal permit, approval, or notification required to implement the work. As specified in Appendix 7B of the Draft DER-10 Technical Guidance for Site Investigation and Remediation (NYSDEC, 2010), NYSDEC may grant exemption from most state permits required for completion of this remedial action, provided the substantive requirements of the permit programs are followed. As such, the construction water treatment and subsequent discharge to the river will meet the substantive requirements of a SPDES discharge permit.

Two federal permits have been identified for the execution of the remedial action.

- The barrier/bulkhead wall is also a replacement for the existing dilapidated timber bulkhead. A USACE NWP No. 3 permit is necessary for the bulkhead replacement activities. A NWP No. 3 joint application (Appendix I) for the bulkhead replacement activities was submitted to the USACE and NYSDEC in November 2017. A costal consistency form was submitted to the New York Department of State as part of the NWP No. 3 application. Subsequently, a no additional action necessary determination was made by New York Department of State. In addition, the New York State Historic Preservation Office (SHPO) was contacted to determine impacts to cultural resources from the project. Subsequently, the New York SHPO determined that no historic properties will be affected by this project.
- The sediment dredging and capping remedial action in the river requires USACE authorizations under Section 404 of the Clean Water Act (CWA) and Section 10 of the Rivers and Harbors Act of 1899 under its NWP Program in NYS; to the NYSDEC for CWA Section 401 Water Quality Certification, authorizations under the NYSDEC Protection of Waters program, Tidal Wetlands, Coastal Erosion Management and NYS Endangered/Threatened Species programs; and a Coastal Consistency Review from the NYS Department of State. A NWP No. 38 joint application (Appendix J) was submitted to the USACE and NYSDEC in January 2018. A costal consistency form was submitted to the New York Department of State as part of the NWP No. 38 application. In addition, the New York SHPO was contacted to determine impacts to cultural resources from the project.

As directed by the NYSDEC, a single NWP No. 38 permit will cover all phases of the in-river work. As a result, the NWP No. 3 and NWP No. 38 permit applications submitted previously will be combined and resubmitted to the USACE and NYSDEC under a single PCN.

For local permits that will be required, a plan will be developed to identify the application requirements, a summary of information required, and application forms. Government contacts will be identified for each permit and a potential schedule for meetings with regulators and application submittals will be developed.

4.2 Regulatory Requirements

Compliance with regulatory requirements applicable to this work was discussed in Section 1, including the following work activities:

- hazardous and non-hazardous waste management (described in Section 3.10);
- wastewater treatment and discharge requirements (described in Section 3.11); and
- air quality maintenance and monitoring (described in Section 5).

4.2.1 Occupational Safety and Health Regulations

Regulations promulgated by Occupational Safety and Health Administration (OSHA) specify safety and health requirements for work procedures at all work places and specifically at construction sites and hazardous waste sites.

Industry standards for work at hazardous waste sites presented in 29 CFR 1910.120 describe specific requirements, including the following:

- preparation of a site-specific HASP;
- training and medical monitoring of personnel who may be exposed to hazardous substances; and
- air monitoring, respiratory protection, and PPE.

A site-specific HASP will be prepared prior to commencement of any remedial activity and forwarded to the NYSDEC and NYSDOH for review. Procedures outlined in the site-specific HASP will provide requirements for daily health and safety review meetings, proper use of safety equipment, proper mechanical equipment use, and other policies. At a minimum, the PPE to be worn on site will include safety glasses, hard hat, and steel-toed shoes or boots. The subjects covered in the HASP will include:

- Health & Safety Risk Analysis;
- PPE;
- Water Safety;
- OSHA Air Monitoring & Action Levels;
- Site Control;
- Decontamination;
- Emergency Response Plan;
- Lockout/Tagout;
- Heavy Equipment Operations;
- Excavation and Trenching;
- Material Safety Data Sheets; and
- Health and Safety Records and Reports.

4.3 Transportation Requirements

The federal Department of Transportation (DOT) has developed requirements that regulate the transportation of hazardous materials by road and rail. Among the hazardous materials identified in these regulations are coal tar distillates. In addition, as discussed above, hazardous waste regulations specify that shipments of hazardous wastes must meet certain requirements presented in the DOT regulations. Specific requirements for hazardous material shipments include the following:

- Shipping papers must include a description of hazardous materials included in the shipment along with the DOT designated identification number and hazard class. Hazardous wastes may not be shipped without a manifest (49 CFR 172.200).
- Each container, package, or vehicle containing a hazardous material must be marked or labeled with the DOT shipping name, technical name, identification number, and hazard class (49 CFR 172.300 and .400).
- Each vehicle or container containing a hazardous material must be appropriately placarded (49 CFR 172.500).
- When hazardous materials are transported, emergency response information must be available at the point of loading, unloading, and during transport.
- Truck routes to and from the site will comply with the Transportation Plan.
- All trucks will have the required licenses and permits, including 6 NYCRR Part 364 Waste Transporter Permits.

5. Quality Assurance & Quality Control

Quality assurance and quality control (QA/QC) procedures will be implemented during the work to ensure that work is completed in conformance with the remedial design, and to provide the basis for implementation of contingency actions, if necessary, to bring the work into conformance with the remedial design.

The following quality assurance procedures and tests will be implemented:

- pre-installation inspection of welded sheets;
- field verification of application of sealant in accordance with manufacturers requirements;
- field verification of barrier/bulkhead wall;
- submittal of weigh tickets for all earthen materials transported to or from the site;
- submittal, prior to the work, of sieve analyses for all imported earthen materials;
- evaluation of the proposed borrow source(s) for imported earthen materials. Analytical data indicating that imported material is non-contaminated will also be submitted;
- surveying of the work limits as necessary;
- field verification of excavation and placed material depths, areas, and volumes;
- field observation of excavation limits; and
- all wastewater influent and effluent will be tested according to the requirements of the SPDES permit equivalent as approved by the NYSDEC.

5.1 QA/QC Procedures

5.1.1 In-River Dredging

QA/QC procedures to be implemented during sediment dredging include:

- use of a GPS guided environmental bucket to ensure that the dredging extends to limits of the dredge area defined in the Decision Document and this Work Plan;
- a field engineer will inspect sediments removed from the bottom of each grid for visual and olfactory impacts. If the field engineer observes impacts, the contractor will be instructed to dredge an additional 6-inches or till no visual or olfactory impacts are observed; and
- when the Contractor has determined that dredging in a series of grids is complete, a post-dredging bathymetric survey will be conducted to verify that target dredge elevations were reached within the required level of accuracy. Grids where the average elevations are greater than the target elevations will be re-dredged until the target elevation is met and verified. No backfill or cover placement will be conducted until the post-dredging survey is completed and the Site engineer certifies that the dredge target elevations and horizontal limits have been met.

5.1.2 River Slope and Utility Capping

All cover material shall meet the requirements of 6 NYCRR Part 375-6.7(d). Minimum requirements for all cover material are as follows:

- all cover material shall be from sources as approved by NYSDEC;
- cover materials shall be tested by the Contractor according to the frequencies established in Section 5.4 of the NYSDEC's DER-10 Technical Guidance for Site Investigation and Remediation (May, 2010). Soil will be sampled for VOCs, SVOCs, inorganics, and PCBs/pesticides at the higher frequency of the DER-10

frequency or a frequency of 2 discrete samples and 1 composite sample (as defined by DER-10) per 5,000 cubic yards of material from each source as approved by the construction manager;

- in accordance with DER-10, laboratory chemical testing is not required for gravel, rock and stone backfill materials that consists of virgin material from a permitted mine or quarry and have a grain size distribution with less than 10% passing the #80 sieve;
- all cover material will be free of stumps, rubbish, frozen materials, and other objectionable materials. Roots, wood, and other natural organic matter is allowable in the habitat layer;
- a sieve analysis shall be conducted for all material sources. Sieve analysis shall be conducted as each new source is introduced and at a frequency of one of one sample for every 500 CY for the first 1,500 CY from each source) and every 5,000 CY thereafter; and
- lightweight pieces (floating) shall be less than 0.5%. This criterion does not apply to the habitat layer.

Underwater divers will inspect the placement of the cap to confirm that it is placed in accordance with the manufacturer's recommendations and adequate overlap of cap seems exist to prevent migration of NAPL. In addition, a bathymetric survey will be completed to ensure that the cap is placed within limits defined in the Decision Document and this Work Plan.

5.1.3 Waste Management

To the extent possible, wastes generated during upland excavation shall be loaded directly into trucks for off-site transportation and sediments generated during dredging shall be loaded directly onto barges for off-site disposal. If stockpile areas are needed, berms and liners shall be used to protect underlying materials from becoming impacted. The stockpiles shall be covered with weighted tarp at the end of each work day to prevent washing in unexpected rain event, spread of dust due to wind, and odors outside the perimeter of the Site. Odor suppressant foam shall also be used as needed. Soils that are too wet for shipment (greater than approximately 20% moisture content) shall be amended with a drying agent (fly ash or similar) or staged on-site to allow the moisture content to be reduced to < 20% through draining or evaporation.

Debris generated during demolition and excavation shall be broken down or cut into pieces suitable for disposal. For subsurface structures, all debris greater than the acceptable to the thermal treatment facility, shall be segregated for disposal at the approved debris landfill. All debris of a size acceptable to the thermal treatment facility or smaller shall be excavated with the soil for transportation to the approved soil disposal facility.

Soils not meeting TCLP requirements for lead shall be shipped to a thermal treatment facility permitted to accept such soils. Soils shipped out of state shall be handled and disposed in compliance with the regulations of the receiving state.

Excavated materials shall be transported in dump trucks or barges to the receiving facilities. Only permitted waste transporters in the State of New York shall be used. The trucks shall be inspected and lined with 6-mil polyethylene liner prior to placement of contaminated soils. The poly will then be sealed at the top to prevent dust or liquid from spreading along the transportation route. The trucks shall be power washed and decontaminated before leaving the Site to prevent spread of contamination on the roadways. Transportation of impacted materials from the Site shall be performed in accordance with all hazardous waste and transportation regulatory requirements and in accordance with the OVDCP and the Transportation Plan. Hazardous waste shipments shall be documented using standard hazardous waste manifests as required by applicable hazardous waste regulations. Other waste materials that have no specific documentation requirements shall be documented using waste tracking forms, bills of lading, and receipts. All shipments of waste from the Site were documented, describing the type and amount of waste and the receiving facility.

5.1.4 Water Management

All construction water generated during this Work Plan as a result of debris decontamination, equipment and personnel decontamination, operation of a dewatering system to support sediment dewatering, and removal of

precipitation shall be collected, treated, and sampled prior to ultimate disposal to a storm sewer in accordance with the SPDES Permit Equivalency.

Water samples shall be collected and submitted to Test America, Inc. for analysis to ensure that the treated water met the SPDES Permit Equivalency limits. Following treatment, the water shall be sampled and discharged, in compliance with NYSDEC requirements

All sediment, coal tar residue, or other solid materials/sludge generated by water management shall be shipped with site soils to an approved thermal treatment facility.

5.1.5 Site Restoration

A survey shall be completed to document that the final river and ground surface meets the final elevation and slope specified in the design documents and this Work Plan.

5.2 Environmental Monitoring and Controls

Environmental controls will ensure that the work activities do not spread impacted sediment, soil and MGP wastes outside the impacted areas and maintain the protection of human health and the environment throughout the remedial activity.

5.2.1 Water Quality Control and Monitoring Plan

In order to prevent control and minimize the dispersion of contamination targeted for removal from the river at the Site to areas outside of the dredge area, a water quality control and monitoring program will be implemented during installation of the barrier/bulkhead wall, dredging of contaminated sediments, backfilling of dredged areas, capping of utility corridors, and regrading and capping of the river bank slope.

The water quality controls and monitoring established in this section will serve as a Remedial Action Monitoring Plan for all in-river work, as described by Chapter 5.1-(e)(2) of DER-10; however, because DER-10 does not inherently specify BMPs or performance standards for dredging and capping remedies, the NYSDEC Technical & Operational Guidance Series (TOGS) 5.1.9, "In-Water and Riparian Management of Sediment and Dredge Material" (November 2004) is employed where appropriate to determine and evaluate water quality controls and monitoring. However, as noted in Section 1.A of TOGS 5.1.9, because the site is managed pursuant to oversight by the DER, the requirements of TOGS are not directly applicable, and are employed for reference purposes only.

The following sections describe the work approach for the planned activities, BMPs to be employed, monitoring methods, performance standards, and response actions to be employed in evaluating the performance of the work. Specifically Section 5.2.1.1 describes the main elements of the in-river work (including dredging, backfilling, utility capping and regrading and capping of the river bank slope) and BMPs that will be employed to maintain water quality, Section 5.2.1.2 describes the monitoring program that will be used to evaluate plan performance and relevant triggers for elevated responses, and Section 5.2.1.3 summarizes mitigation and response actions.

5.2.1.1 Background Monitoring

Measurement of background turbidity levels will take place prior to the start of in-river remedial activities. Background measurements will take place for a minimum of three days and collection locations will include:

- Directly in front of site;
- East of the site along the eastern dredge boundary;
- North of the site along the northern dredge boundary;
- South of the site along the southern dredge boundary; and
- 100 feet downgradient of the City of Poughkeepsie drinking water intake location.

The background (ambient) measurements will support the development of turbidity action levels during the implementation of the water quality monitoring program.

5.2.1.2 Work Approach

Several technical approaches will be employed to complete different in-river aspects of the work for the duration of the project, specific to the remedial objectives and related limitations at specific locations within the work area. The primary remedial action to be employed is targeted dredging of river sediments within the work area that have been impacted by NAPL. Dredged areas will be restored predominantly through backfill of certain portions of the dredge area. In areas where utility location prevents dredging, a sediment capping approach will be employed to control continued migration of NAPL. Additionally, a barrier/bulkhead wall will be installed to prevent migration of residual contamination on-site towards the river and stabilize and strengthen portions of the Site shoreline. Finally, the river bank (which cannot be dredged due to stability concerns) will be regraded to a stable slope and capped. The following sections detail the work plan and water quality control measures for each of these primary near-river and in-river activities.

Dredging

As required by the Decision Document, sediments that are visually impacted by NAPL will be dredged, removed from the Site, and processed off-site for disposal. The estimated in-situ volume of sediment to be dredged, including side slopes necessary to maintain stability of the river bottom during the work and accounting for areas which cannot be dredged due to the buried utilities and their associated safety offsets is approximately 40,000 cy, across an area of approximately 4.2 acres. Dredging is anticipated to occur from October through February to comply with in-river work windows developed to mitigate or eliminate potential impacts to natural resources in the river, including threatened and endangered species and essential fish habitat. When dredging is occurring, the following equipment and operational constraints and turbidity controls will be employed as BMPs to protect water quality:

- dredging will be conducted by mechanical means, using an “environmental” clamshell bucket; the environmental clamshell provides specific advantages versus traditional clamshells in maintaining water quality:
 - gaskets and vent flaps seal the bucket when in the closed position (i.e., after a cut has been made) to provide hydraulic separation between the dredged material in the bucket and the water column; and
 - specially designed linkages in the clamshell result in a level cut of the sediment surface, which minimizes re-suspension at the dredge cut surface and provides greater control of the post-dredge sediment surface.
- all dredging will be performed within a containment cell to contain re-suspended sediments and, to the maximum extent practicable, prevent the migration of suspended sediments (and therefore, contaminants) into the river. Typical views of the containment cell are provided in Figures 3-3 through 3-5, and include the following elements:
 - a floating perimeter frame with dimensions of approximately 140 feet by 140 feet will be attached to the floating crane platform, providing support for the functional elements of the containment cell at the water surface;
 - impermeable sections of PVC-coated polyester, extending 10 feet down from the top of the water column and 10 feet up from the bottom of the containment cell provide containment of dense NAPL which may be exposed during dredging at the bottom of the water column and NAPL sheens at the water surface;
 - a monofilament geotextile filter fabric with an apparent opening size equivalent to a #70 sieve (nominal opening size of 0.210 mm [0.01 in]) serves as a turbidity curtain between the upper and lower impermeable barriers to retain re-suspended sediments within the containment cell; the filter fabric is rated for a flow rate of 18 gallons/minute/square foot, equivalent to a water velocity of 2.4 ft/second [1.43 knots]; and
 - ballast chains at the bottom and mid-depth of the vertical face of the containment cell provide necessary tension to keep the bottom of the cell on location and reduce billowing of the filter fabric due to current flows.

- vertical velocity of the dredge bucket during ascent will be limited to the extent possible, limiting downward pressure on the bucket gaskets which would otherwise tend to push dredged sediments out through the bottom of the dredge bucket;
- positioning technologies, including GPS with real-time kinematic correction, will be used to allow the operator to be aware of the exact location of the dredge within the work area;
- barges will be inspected prior to beginning the work and at regular intervals to ensure water tightness during dredging and sediment transport;
- barge overflow will be prohibited;
- decanting of retained water within the environmental bucket will be permitted only within the containment cell, and only using drain valves provided on the bucket; all other retained water will be transferred to the material barge along with the dredged sediment;
- dredged sediment will not be re-handled at the Site; excess water will be removed from material barges and transferred to an on-site water treatment plant after sufficient settling has been achieved by pump. Amendment, offloading and treatment of dredged sediments will take place only at an appropriately-permitted off-site location;
- instrumented monitoring of turbidity levels up- and downgradient of the Site will be used to evaluate sediment re-suspension and, where necessary, trigger changes to the dredging procedure to control sediment re-suspension and this minimize water quality impacts. The functioning of the turbidity monitoring and associated action levels are detailed below in Section 5.2.1.2, and the associated mitigation actions are described in Section 5.2.1.3;
- deployment of floating oil absorbent booms roughly 500 feet down current of the work. These booms will be deployed for the first several weeks of work. If no releases are found in the material after that, then adaptive management techniques will be implemented; and
- A patrol boat will be present in the water during dredging operations; if sheens or plumes are identified in the river downstream of the dredging work area, the dredging operation will be revised as necessary to eliminate the release.

Backfilling

In areas where the post-dredging sediment surface is more than two feet lower than the pre-dredging sediment surface, granular backfill will be placed to bring the river bottom surface to within two feet of the pre-dredging elevation. When backfilling is underway, the following equipment and operational constraints and turbidity controls will be employed as BMPs to protect water quality:

- backfill will be placed as a sand water slurry via tremie pipe, discharging at the minimum practical height above the post-dredging surface. Because the material will be slurried with water and is granular, minimal mechanical disruption of the dredged surface is expected;
- slurry flow rates and solids content will be adjusted as necessary to control re-suspension based on visual and instrumentation observations of turbidity;
- instrumented monitoring of turbidity levels up- and downstream of the backfill operation will be used to evaluate sediment re-suspension and, where necessary, trigger changes to the backfill procedure to control sediment re-suspension and thus minimize water quality impacts. The functioning of the turbidity monitoring and associated action levels are detailed below in Section 3.2.1.2, and the associated mitigation actions are described in Section 3.2.1.3; and
- a patrol boat will be present in the water during backfill operations; if sheens or plumes are identified in the river downgradient of the backfill work area, the backfilling operation will be revised as necessary to eliminate the release.

Utility Capping

In areas within the utility crossing safety offsets, capping of the sediment surface will be completed in lieu of dredging. The cap will consist of a RCM overlain articulated concrete blocks to protect the mats and keep them in place. The RCM and articulated concrete blocks will be preassembled into panels (as shown in Figure 3-14) and placed onto the sediment surface through the water column by crane. GPS will be used to establish positioning at the water surface, and divers will be used at depth to ensure proper placement and connection of the individual panels into a single, cohesive cap. Sediment resuspension during the capping work is expected to be minimal as there is no excavation involved; the only mechanical disturbance to the sediment surface would be as the individual panels reach and are placed on the river bottom. The following procedures will be used to maintain water quality during cap placement:

- vertical velocity of the panel during lowering will be limited, to extent feasible, to limit the impulse delivered to the river bottom upon placement; minimal sediment will become re-suspended at the edges of the panel being lowered, limiting the potential for impacts to water quality;
- instrumented monitoring of turbidity levels up- and downstream of the capping site will be used to evaluate sediment re-suspension and, where necessary, trigger changes to the capping procedure to control sediment re-suspension and this minimize water quality impacts. The functioning of the turbidity monitoring and associated action levels are detailed below in Section 3.2.1.2, and the associated mitigation actions are described in Section 3.2.1.3; and
- a patrol boat will be present in the water during capping operations; if sheens or plumes are identified in the river downgradient of the capping work area, the capping operation will be adjusted as necessary to eliminate the release.

Barrier/Bulkhead Wall Construction

A combination barrier and bulkhead wall will be installed along the site shoreline to provide hydraulic isolation of residual NAPL and prevent migration into the river, and in the southern portion of the site to strengthen the shoreline. As described above, the barrier/bulkhead wall will be constructed of steel sheet piling; the barrier wall portion will be constructed of sheeting driven in pairs with internal interlocks fully welded and interlocks between welded pairs treated with hydraulic sealant. The bulkhead wall portion will also be constructed of pre-welded pairs, although the welding will not be continuous. All sheeting will be installed using vibratory pile driving technology, with the barrier wall portion installed by land-based equipment and the bulkhead portion constructed by water-based equipment. In either case, sediment re-suspension may be caused by mechanical disruption of the shoreline in close proximity to the water, and vibratory impulses from the driving and transmitted through the sheeting and into the overburden. Any sediment re-suspension that does occur is expected to be limited to the immediate vicinity of the sheeting being actively driven. The following procedures will be used to maintain water quality during installation of the barrier/bulkhead wall:

- turbidity curtains will be placed in the river in the vicinity of barrier/bulkhead wall installation work as shown in Figure 3-1. Sheeting installation will be conducted partially by land-based equipment and partially by water-based equipment; in either case, turbidity curtains with absorbent booms will be placed around the work area to control both sediment re-suspension and sheens at the water surface.
- turbidity curtain placement must comply with the following:
 - turbidity curtains will be established around the sheetpile installation operation in phases, appropriate to the progress of the work; the upstream and downstream anchoring point must be installed within 200 feet of work area.
 - turbidity curtains must be long enough to cover at least half the depth of the water column.
 - turbidity curtains must not extend out more than 25 feet riverward of the toe of the slope.
- a patrol boat or upland observers will be present during sheetpile installation; if sheens or plumes are identified in the river downstream of the wall installation work area, the work operation will be modified as necessary to eliminate the release.

River Slope Grading and Capping

The river bank slope cannot be dredged due to upland stability concerns; regrading of the slope and capping will be completed in lieu of dredging. Similar to the utility cap, the cap will consist of a RCM overlain by articulated concrete blocks to protect the mats and keep them in place. The RCM and articulated concrete blocks will be preassembled into panels (as shown in Figure 3-14) and placed onto the sediment surface through the water column by crane. GPS will be used to establish positioning at the water surface, and divers will be used at depth to ensure proper placement and connection of the individual panels into a single, cohesive cap. While regrading of the river bank slope is likely to cause sediment re-suspension, the capping work is expected to cause minimal sediment re-suspension as there is no excavation involved; the only mechanical disturbance to the sediment surface would be as the individual panels reach and are placed on the river bottom. The following procedures will be used to maintain water quality during river bank slope regrading and capping:

- turbidity curtains will be placed in the river in the vicinity of active slope regrading work. Regrading will be conducted partially by land-based equipment and partially by water-based equipment; in either case, turbidity curtains with absorbent booms will be placed around the work area to control both sediment re-suspension and sheens at the water surface;
- turbidity curtain placement must comply with the following:
 - turbidity curtains will be established around the regrading and capping operation in phases, appropriate to the progress of the work; the upstream and downstream anchoring point must be installed within 200 feet of work area;
 - turbidity curtains must be long enough to cover at least half the depth of the water column;
 - turbidity curtains must not extend out more than 25 feet riverward of the toe of the slope.
- a patrol boat or upland observers will be present during the regrading and capping operations; if sheens or plumes are identified in the river downstream of the regrading and capping work area, the work operation will be modified as necessary to eliminate the release.

5.2.1.3 Water Quality Monitoring Approach

A program to monitor water quality has been developed considering available equipment which can provide feedback in real time to the project team during in-river construction, in order to maintain water quality in the river with minimum lag between identification of field conditions and implementation of control measures as needed. To that end, monitoring will rely primarily of measurement of turbidity in the river during dredging, backfilling and utility cap placement to identify whether releases of sediment from the work area are occurring, and appropriate action levels.

TOGS 5.1.9 identifies total suspended solids (TSS) of 100 ppm above ambient conditions as a presumptive threshold of acute toxicity. Additionally, the narrative water quality standard at 6 NYCRR Part 703.2 prohibits any increase in turbidity that causes a substantial visible contrast to natural condition. TSS cannot be measured in real-time; however, a generally accepted correlation is that there is a 1 ppm to 1 NTU relationship between TSS and turbidity. The validity of this correlation can be impacted by biological contributions to turbidity, though this impact is likely minimized in high-flow environments such as the river. Nevertheless, as turbidity is the only parameter that can be measured in real-time and which provides some level of correlation to actual TSS levels, turbidity will be used as the primary monitoring parameter to evaluate the effectiveness of water quality controls for the duration of in-river work.

The point at compliance with water quality standards is generally evaluated is at the limit of the mixing zone, which is defined as a limited volume of water in close proximity to the work being conducted within which exceedances of water quality standards may be deemed acceptable. As defined by TOGS 5.1.9, the mixing zone in rivers and river-like sections of estuaries (such as the Hudson River) should not extend beyond the lesser of 500 feet or one third the width of the river; in the case of the river at Poughkeepsie, where the river is approximately 2,500 feet in width, the default mixing zone of 500 feet would therefore apply. An exception to the default mixing zone size would apply in the event there is a significant resource that may be impacted; however, there are no wetlands (other than the tidal wetlands of the river itself), protected habitats or other resources of significant ecological value inside of or within 500 feet of the proposed work areas. Accordingly, the mixing zone (and therefore, the maximum distance between an active work area and a monitoring location) is set at 500 feet for purposes of evaluating water quality impacts resulting from the proposed work.

Turbidity will be evaluated by the use of continuous monitors affixed to upstream and downstream buoys, which will be moved along with the work, and located within 500 feet of ongoing work at all times and communicate via radio or cellular data connections to a base monitoring station. A minimum of three monitoring buoys will be deployed at all times, with at least one buoy located upstream of the work area in order to provide background turbidity measurements as well as measure any potential water quality issues emanating from the work activity and potentially impacting the City of Poughkeepsie drinking water intake. Although the river is tidal (and therefore, which direction is upstream will change twice daily), river currents are such that it is expected that “carryover” effects as one monitoring station transitions from functioning as a downstream monitoring point to an upstream monitoring point will dissipate quickly, and the use of a monitoring station within 500 feet of the work area as a background station is acceptable. However, in the event that statistically significant differences are observed between monitoring stations (indicating a project-related contribution to TSS), and these do not dissipate within 15 minutes after flow direction changes, relocation of the third buoy or installation of an additional buoy at a further distance upstream will be evaluated.

Initially, an increase of 100 NTU in the downstream turbidity as opposed to the upstream turbidity will be considered evidence of an unacceptable rate of sediment re-suspension, and additional controls such as reduction in production rates or deployment of additional turbidity curtains will be implemented, depending on the apparent means of sediment transport, as described in further detail in Section 3.4.2.3. Similarly, an increase of 100 NTU in the upstream turbidity as opposed to the background turbidity (measured prior to start of work) will be considered evidence of an unacceptable rate of sediment re-suspension. Additional control measures such as reduction in production rates or deployment of additional turbidity curtains will be implemented, depending on the apparent means of sediment transport, as described in further detail in Section 3.4.2.3. In addition, if needed, sampling of Hudson River water to evaluate the validity of the 1 ppm TSS to 1 NTU correlation may be conducted, and if the correlation is found to exceed this ratio the action triggers may be revised (in consultation with the NYSDEC) accordingly.

5.2.1.4 Contingency Plan, Mitigation, and Response

If monitoring indicates an unacceptable increase in turbidity in the water column at the edge of the mixing zone, as measured by the buoy-mounted turbidity meters or by visual observation of a plume that substantially contrasts against natural river conditions, various response actions may be considered, depending on the type of work underway and the severity of the exceedance. Potential response actions include the following options, depending on the work activity causing the exceedance:

- dredging – An excessive level of turbidity at the edge of the mixing zone may be due to one or more causes, and the appropriate response will depend on the apparent source(s) of the excessive resuspended sediment. Likely causes of excessive sediment re-suspension include:
 - leakage from the environmental bucket;
 - loss of dredged sediment may result if mechanical seals are functioning properly, or if excessive debris prevent proper closure. The bucket should be inspected and maintained per manufacturer specifications at all times; if sediment loss is observed to be occurring due to debris, consider adjusting bite sizes to allow for room for debris to shift during bucket closure, and/or use alternate equipment to remove debris prior to production dredging. If the bucket is closing completely but excessive sediment loss continues, maintain or replace gaskets and flaps consistent with bucket manufacturer maintenance specifications; and
 - evaluate production rate and verify that work speed is within specifications and/or equipment tolerances; excessive speed in lowering and raising the bucket may result in inaccurate placement of the bucket (e.g., impacting the sediment surface at too high of a velocity) or exceeding the capacity of seals and gaskets to relieve excess water pressure caused by bucket movement. If necessary, increase cycle time (i.e., raise and/or lower the bucket at a slower velocity) until sediment re-suspension is within the acceptable range.
- transport of re-suspended sediment through containment cell – re-suspended sediment may be transported downstream through defective, damaged or incorrectly installed turbidity curtain or impermeable barrier materials. If the sediment loss and re-suspension rates within the containment cell appears to be within expected ranges for the dredging operation but excessive turbidity or a sheen is observed outside the containment cell:

- verify that the bottom of the containment cell is at the proper elevation for the area being dredged, and is not in direct contact with and re-suspending sediment from the river bottom; adjust containment cell bottom to an appropriate depth;
 - inspect and repair turbidity curtain material (filter fabric) and/or impermeable top and bottom barriers (PVC-coated polyester); submerged debris; and
 - increase ballast weights at bottom and/or mid-height of the turbidity curtain to limit underwater movement of containment cell components.
- backfilling – An excessive level of turbidity at the edge of the mixing zone during backfill operations may most likely be due to three potential operational parameters:
 - excessive flow rate – If the slurry of granular material is being pumped too high of a flow rate, the pipe outlet will act like a jet to push aside and re-suspend the finer grained materials at the dredged surface, which will in turn re-suspend into the water column. Evaluate hydraulic conditions of the backfill placement and either reduce the flow rate or alter the slurry makeup to minimize the jet effect on the sediment surface;
 - discharge location at an inappropriate elevation – The optimal depth at which the slurry should be discharged depends on the depth of the dredge cut in that area and the overall depth of water, and river hydraulics. If the discharge is too far from the bottom, slurry materials may drift and as the concentration of solids in the slurry dissipates, the granular material itself may act re-suspended sediment. If the discharge point is too low, excessive contact with the sediment surface may occur, resulting in sediment re-suspension; and
 - river hydraulics – Under certain flow conditions, the re-suspension of river sediment or loss of backfill material to the current becomes likely. If current velocities are approaching or exceeding the point at which incipient motion of river sediment occurs, consider reducing slurry flow rate or suspending backfill operations until more quiescent condition prevail.
 - Utility Capping – Excessive sediment re-suspension during placement of the utility cap is most likely to occur in the event a prefabricated panel is lowered at an excessive velocity. The water beneath the mat as it is lowered acts as a plow and must escape around the edges as the panel approaches the sediment surface. Further, the mechanical disturbance of the panel impacting the sediment surface will also disturb sediment. If sediment is being re-suspended during cap placement, reduce the velocity at which the panels are lowered through the water column.
 - Barrier/Bulkhead Wall Installation– Excessive sediment re-suspension during installation of the barrier/bulkhead wall is most likely to occur due to mechanical disruption of the slope surface or transmission of vibration in the overburden, releasing sediment into the water column. The relatively lower currents at the shoreline and the lower overall mass flux due to the lower productivity of the sheet pile installation process should serve to control re-suspension rates. However, if excessive re-suspended sediment is generated and migrates beyond the turbidity curtain, adjust the energy of the vibratory hammer to limit transmission of excessive vibration.
 - River Bank Slope Regrading and Capping – Excessive sediment re-suspension during the regrading and capping of the river bank slope is most likely to occur during regrading. Sediment re-suspension will occur as land and water-borne equipment reworks the slope, releasing sediment into the water column. The relatively lower currents at the shoreline and the lower overall mass flux due to the lower productivity of the river bank work should serve to control re-suspension rates. However, if excessive re-suspended sediment is generated and migrates beyond the turbidity curtain, adjust the speed and force used by the earthmoving equipment until the turbidity level is within the acceptable range at the edge of the mixing zone. Excessive sediment re-suspension during placement of the cap is believed to be unlikely since this will be a primarily manual operation, but if needed the mitigation measures identified for the utility cap (above) may be considered.

The City of Poughkeepsie will be kept informed of the remedial work being conducted downstream of the drinking water intake. In addition to the real-time turbidity monitoring being conducted upstream of the drinking water intake, visual inspection of areas downstream of the drinking water intake will take place on a daily basis. If a visual

observation of NAPL is made a water quality sample will be collected 100 feet from the drinking water intake and analyzed for site contaminants. Contingencies will include stoppage of work and deployment of oil booms.

5.2.2 Odor, Vapor, and Dust Control

An Odor, Vapor, and Dust Control Plan that describes the potential sources of fugitive emissions, the potential receptors and the three levels of controls that will be implemented at the site is included as Appendix B.

In summary, an odor and vapor suppressing foam will also be available during the remedial activity to contain air emission sources. The foam and/or BioSolve will be a direct-contact, spray-on foam/surfactant, applicable to soil and MGP residuals, that provides an impermeable barrier and has a minimum effective duration of 7 days in all weather conditions. Odor suppressing foam and plastic sheeting (or other approved methods, including BioSolve and similar products) will be available onsite at all times, for all soil excavations. The necessary application equipment and plastic sheeting will be brought onsite during mobilization, along with odor neutralization concentrate.

5.2.3 Air Monitoring

Site perimeter and work zone air monitoring will be performed per NYSDOH and Occupational Safety and Health Administration (OSHA) requirements, and according to a site-specific CAMP (Appendix B) and HASP. The contaminants of concern are VOCs and particulates.

Monitoring will be continuous during the excavation, dredging, and handling of impacted soils and sediments. Monitoring will be periodic during non-intrusive activities such as mobilization and equipment decontamination.

Summaries of all air monitoring data will be provided to the appropriate parties' regulatory agencies on a weekly basis to facilitate the transfer of information related to potential health risks.

5.2.4 Erosion and Sediment Control

The remediation activities will disturb an area greater than one acre in size. Therefore, the work, being performed under a BCA, will meet the substantive requirements of a SPDES Phase II Construction Storm Water Permit.

Erosion will be prevented and sediment will be controlled during all onsite earthwork activities in accordance with the applicable New York State guidance. Stormwater run-on will be controlled to prevent contact with impacted soils. Any stormwater that does contact impacted soils will be diverted to the temporary water treatment system. Hay bales, silt fence, and rip rap will be used to prevent erosion of exposed soils.

Onsite decontamination pads will be used to remove mud from truck tires and prevent tracking of mud and impacted soil onto the streets as shown in Figure 3-2.

5.2.5 Noise and Vibration Evaluation

The planned activities have the potential to generate noise and vibration. Noise Monitoring and Vibration Settlement Plans have been developed for site activities and are included as Appendix B. Site specific alert and action levels are established for the RA to ensure the work is performed in compliance with federal, state, and local laws as well as to provide an early warning system for any exceedances that may affect any sensitive receptors.

6. Schedule

Contingent on receipt of required necessary permits, the remedial action activities are planned to begin as follows:

- Phase I Landside Excavation – June to July 2018
- Phase II Barrier/Bulkhead Wall – July through September 2018
- Phase III In-River Work – October 2018 through February 2019
- Phase III In-River Work (Cap Installation) – July 2019 through September 2019
- Phase IV NAPL Collection Wells – May 2019
- Phase V SMP and FER Submission – May 2020

7. References

ARCADIS. 2010. *Remedial Investigation Report*, North Water Street Site, Prepared for CHGE, December, 2010.

Arcadis, 2014. *Remedial Alternative Analysis Report*, North Water Street Site, Poughkeepsie, New York, May 2014.

Blasland, Bouck & Lee, Inc. 2000. *Personal communication with John Glass*, Dutchess County Department of Health, August 1, 2000.

Dutchess County Department of Planning and Development, 2015. City of Poughkeepsie Zoning Map, December 28, 2015. Available online at: <http://www.co.dutchess.ny.us/CountyGov/Departments/Planning/poughkeepsiecity.pdf>.

EA Science and Technology. 1987. *Phase I Investigation*, Poughkeepsie (North Water Street) Coal Gasification Plant Site, City of Poughkeepsie, Dutchess County, New York. Prepared for CHGE, January 1987.

Fischenich, J.C. 2003. *Effects of Riprap on Riverine and Riparian Ecosystems*. ERDC/EL TR-03-4. U.S. Army Engineer Research and Development Center, Vicksburg, Mississippi.

Francingues, N. R., and Palermo, M. R. (2005). *Silt Curtains as a Dredging Project Management Practice*, DOER Technical Notes Collection (ERDC TN-DOER-E21). U.S. Army Engineer Research and Development Center, Vicksburg, MS.

Frimpter, M.H. 1972. *Ground-Water Resources of Orange and Ulster Counties*, New York, Geological Survey Water-Supply Paper, 1985, United States Government Printing Office, Washington.

New York State Department of Environmental Conservation, (NYSDEC), 2005. *New York Standards and Specifications for Erosion and Sediment Control*, August 2005.

NYSDEC, 2010. DER-10, *Technical Guidance for Site Investigation and Remediation*. June 2010.















NYSDEC, 2016. *Decision Document, Former CH-Water Street MGP Site, Poughkeepsie, Dutchess County, New York*, March 2016.

Figures



File: P:\Jobs\Rem_Eng\Project Files\CHGE\900 CAD\910 CAD\20 SHEETS\RDRA Work Plan.dwg Layout: 1-2A User: erica.hart Plotted: Feb 01, 2018 - 8:35am Xref's:

LEGEND



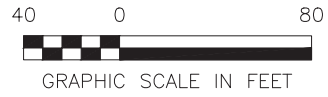
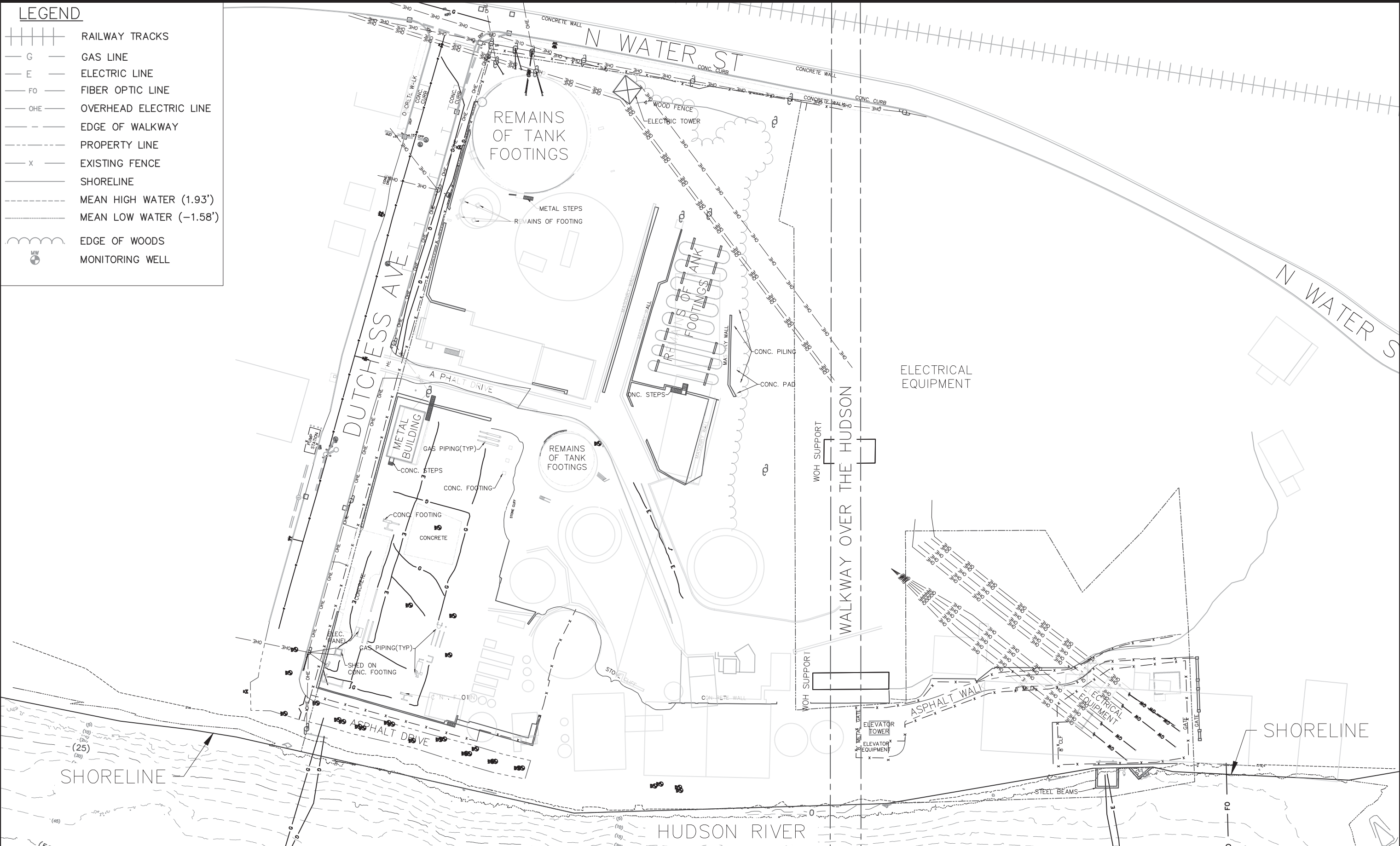







-  RAILWAY TRACKS
-  G — GAS LINE
-  E — ELECTRIC LINE
-  FO — FIBER OPTIC LINE
-  OHE — OVERHEAD ELECTRIC LINE
-  — — — EDGE OF WALKWAY
-  - - - - - PROPERTY LINE
-  x — — — EXISTING FENCE
-  — — — SHORELINE
-  - - - - - MEAN HIGH WATER (1.93')
-  - - - - - MEAN LOW WATER (-1.58')
-   — — — EDGE OF WOODS
-  MW — — — MONITORING WELL

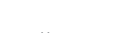
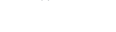

CENTRAL HUDSON GAS & ELECTRIC CORP. FORMER NORTH WATER STREET MGP POUGHKEEPSIE, NY		UPLAND SITE LAYOUT MAP EXISTING CONDITIONS
DATE: 2/1/2018	NYSDEC SITE ID: 60540671	REMEDIAL DESIGN/REMEDIAL ACTION WORK PLAN
FIGURE 1-2A		

File: P:\Jobs\Rem_Eng\Project Files\CHGE\900 CAD\910 CAD\20 SHEETS\RDRA Work Plan.dwg Layout: 1-2B User: erica.hart Plotted: Feb 01, 2018 - 2:45pm Xref's:

LEGEND

-  RAILWAY TRACKS
-  GAS LINE
-  ELECTRIC LINE
-  FIBER OPTIC LINE
-  OVERHEAD ELECTRIC LINE
-  EDGE OF WALKWAY
-  PROPERTY LINE
-  EXISTING FENCE
-  SHORELINE
-  EDGE OF WOODS
-  MONITORING WELL
-  GATE

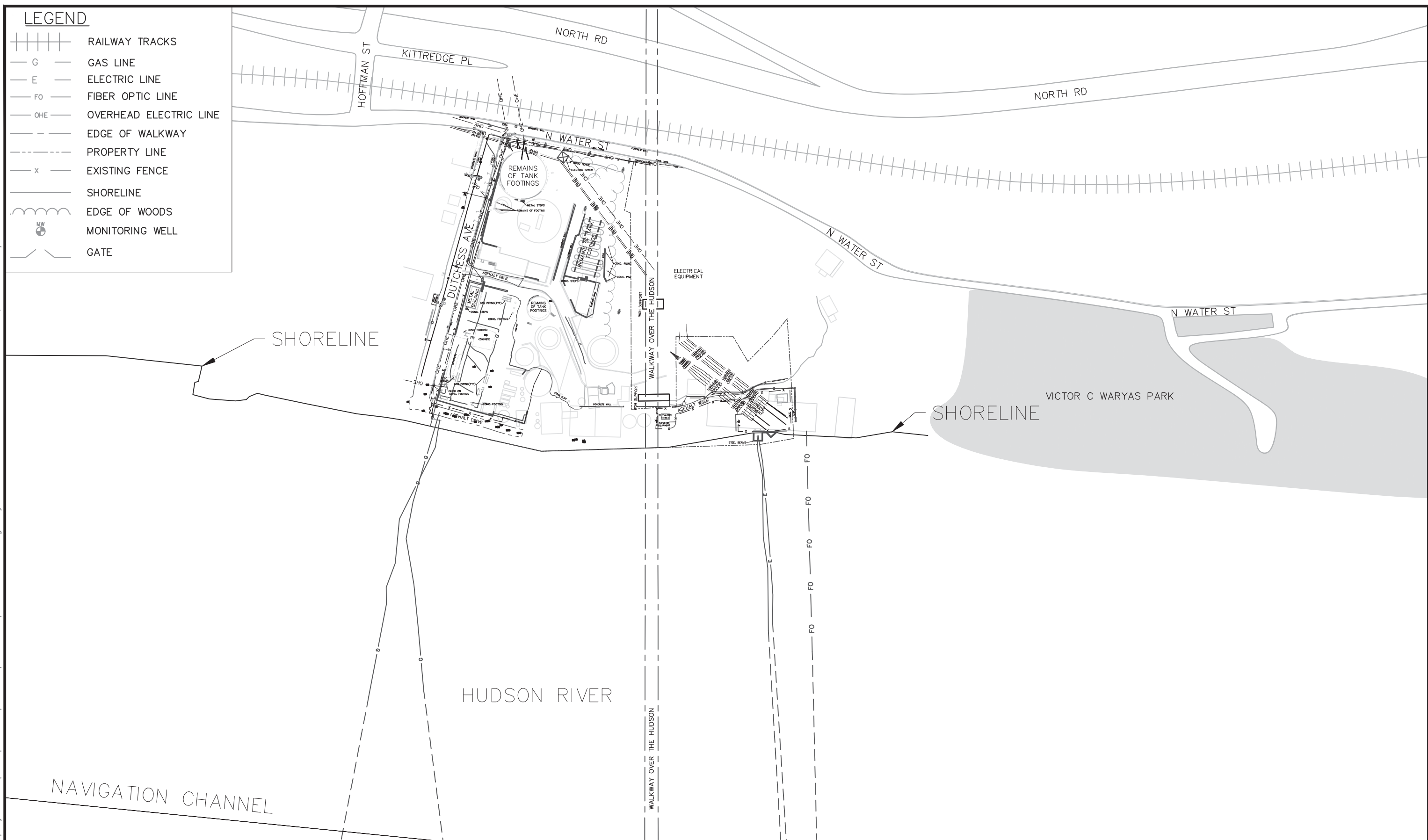

NOTES: NEAREST WATER INTAKE IS APPROXIMATELY 2,865 FEET TO THE NORTHERN MOST POINT OF THIS FIGURE.

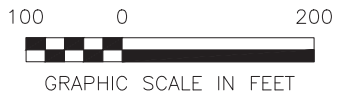

CENTRAL HUDSON GAS & ELECTRIC CORP. FORMER NORTH WATER STREET MGP POUGHKEEPSIE, NY		SITE LAYOUT MAP EXISTING CONDITIONS	
DATE: 2/1/2018	NYSDEC SITE ID: 60540671	REMEDIAL DESIGN/REMEDIAL ACTION WORK PLAN	FIGURE 1-2B

File: P:\Jobs\Rem_Eng\Project Files\CHGE\900 CAD\910 CAD\20 SHEETS\PDF\RDRA\RDRA Work Plan.dwg Layout: 1-3 User: sirventj Plotted: Aug 01, 2018 - 4:39pm Xrefs:

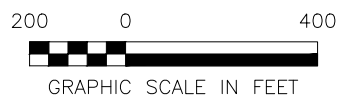
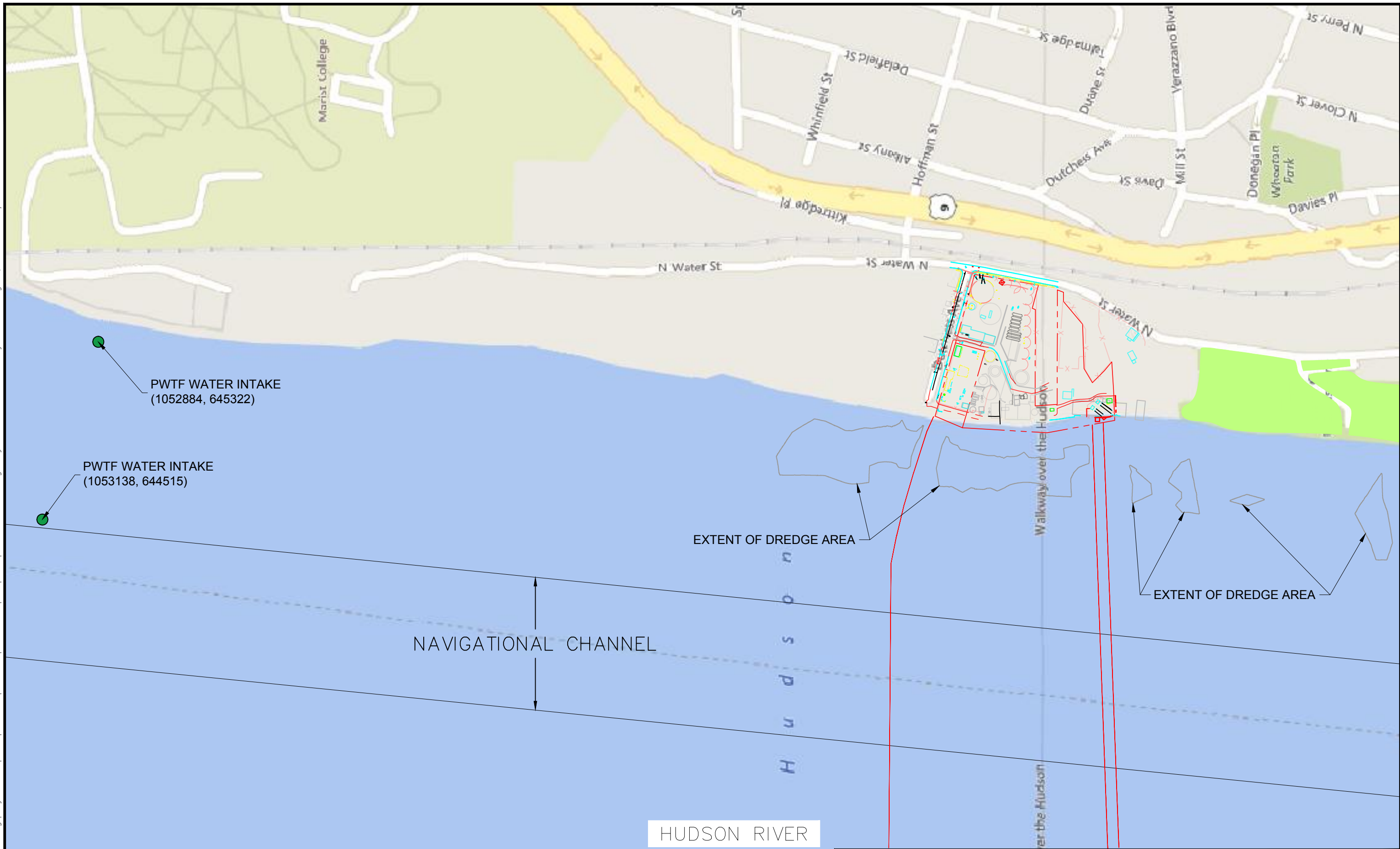

CENTRAL HUDSON GAS & ELECTRIC CORP.
FORMER NORTH WATER STREET MGP
POUGHKEEPSIE, NY

LOCATION OF NAVIGATIONAL CHANNEL
AND PWTf WATER INTAKE

DATE: 8/01/2018











NYSDEC SITE ID: 60540671

REMEDIAL DESIGN/REMEDIAL ACTION WORK PLAN

FIGURE 1-3

File: P:\Jobs\Rem_Eng\Project Files\CHGE\900 CAD\910 CAD\20 SHEETS\RDRA Work Plan.dwg Layout: 2-1 User: erica.hart Plotted: Feb 01, 2018 - 8:39am Xref's:

LEGEND



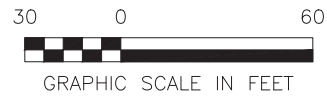
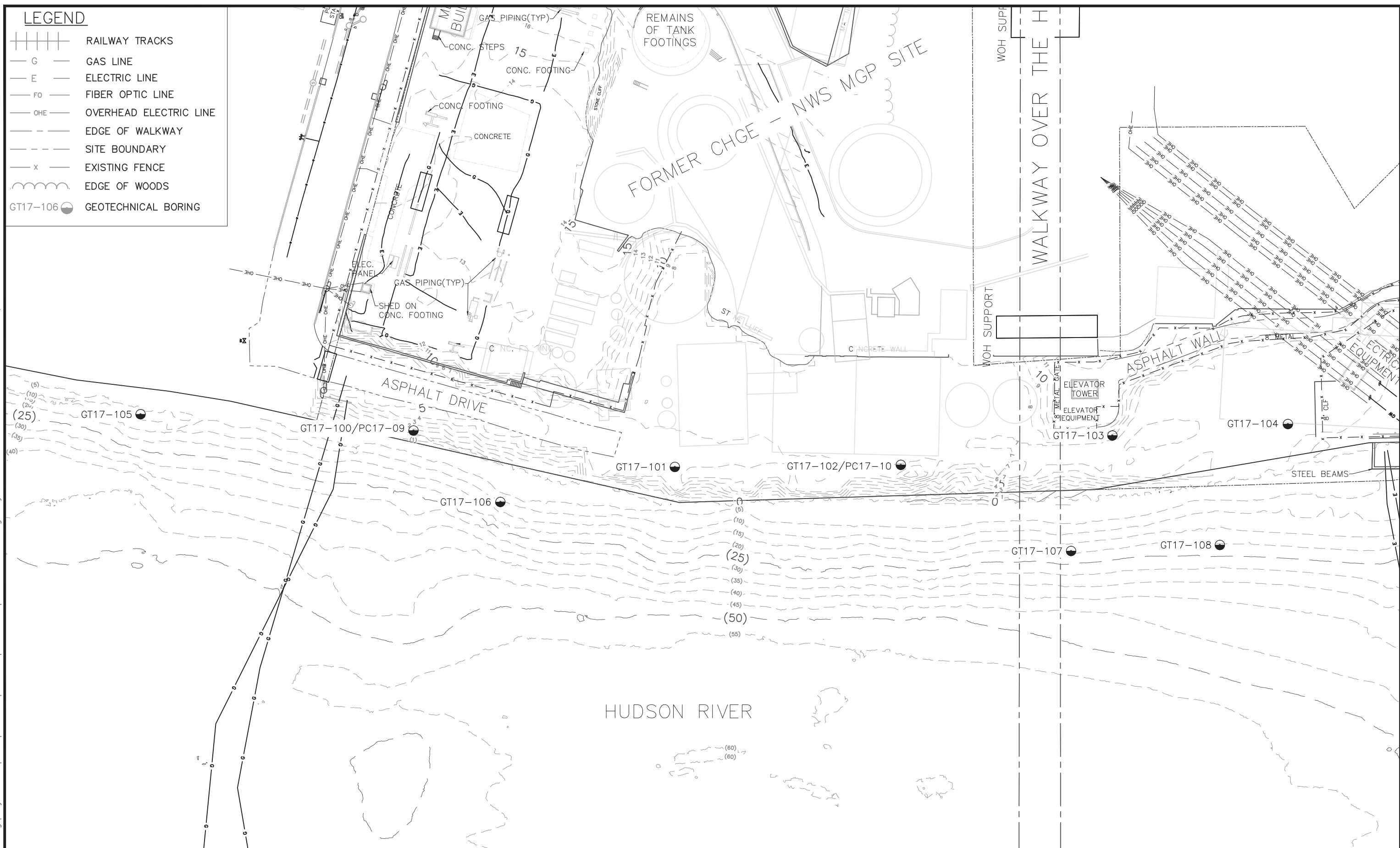







-  RAILWAY TRACKS
-  G GAS LINE
-  E ELECTRIC LINE
-  FO FIBER OPTIC LINE
-  OHE OVERHEAD ELECTRIC LINE
-  --- EDGE OF WALKWAY
-  - - - SITE BOUNDARY
-  x EXISTING FENCE
-  ~~~~~ EDGE OF WOODS
-  GT17-106 GEOTECHNICAL BORING



CENTRAL HUDSON GAS & ELECTRIC CORP. FORMER NORTH WATER STREET MGP POUGHKEEPSIE, NY		PDI GEOTECHNICAL BORING LOCATIONS	
DATE: 2/1/2018	NYSDEC SITE ID: 60540671	REMEDIAL DESIGN/REMEDIAL ACTION WORK PLAN	FIGURE 2-1

File: P:\Jobs\Rem_Eng\Project Files\CHGE\900 CAD\910 CAD\20 SHEETS\RDRA Work Plan.dwg Layout: 2-2 User: erica.hart Plotted: Feb 01, 2018 - 8:45am Xref's:

LEGEND

-  RAILWAY TRACKS
-  G — GAS LINE
-  E — ELECTRIC LINE
-  FO — FIBER OPTIC LINE
-  OHE — OVERHEAD ELECTRIC LINE
-  — — — — — EDGE OF WALKWAY
-  - - - - - SITE BOUNDARY
-  x x x x x EXISTING FENCE
-  ~ ~ ~ ~ ~ EDGE OF WOODS
-  SB17-100 SOIL BORING LOCATION
-  [] TEST PIT LOCATION

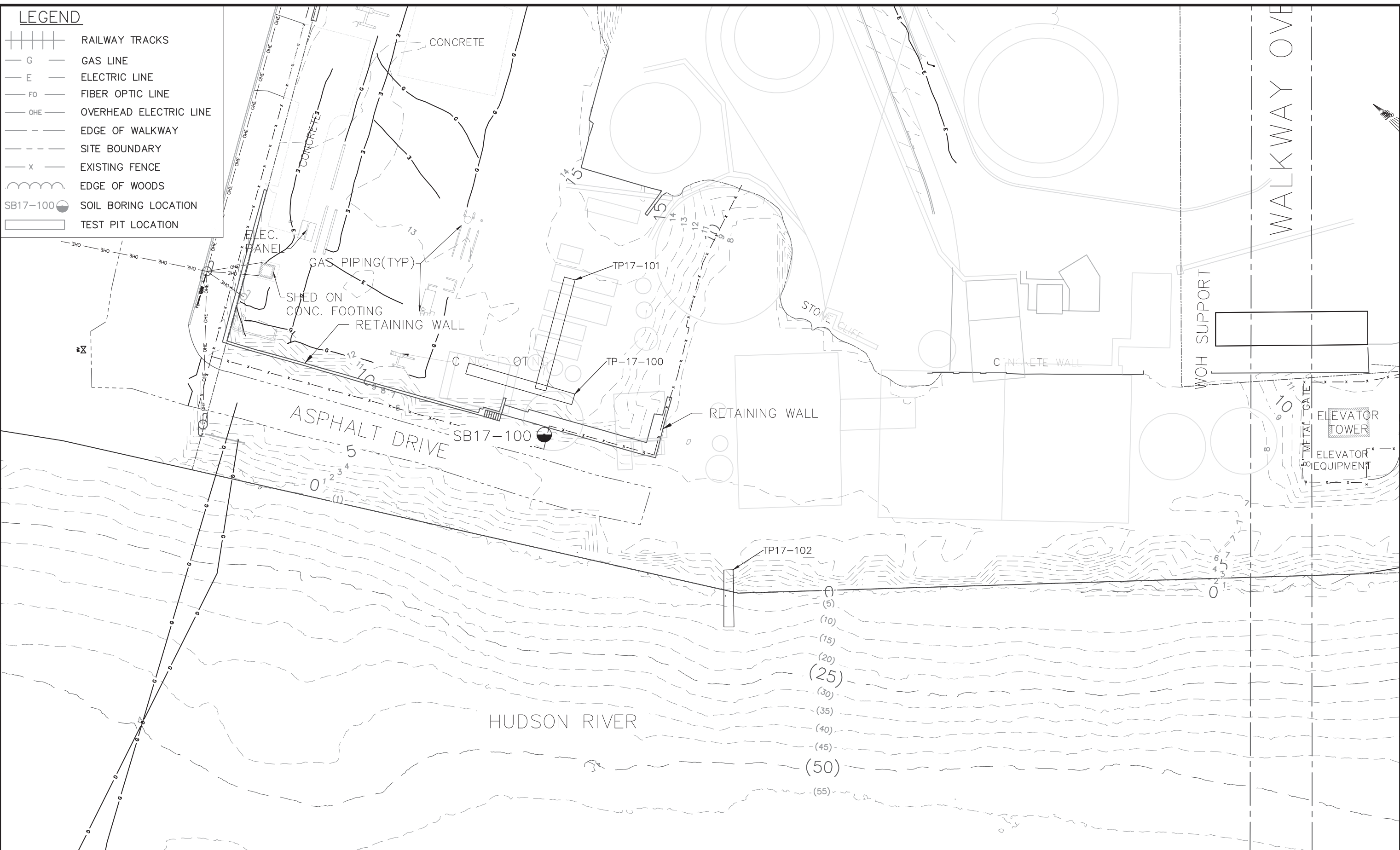

CENTRAL HUDSON GAS & ELECTRIC CORP. FORMER NORTH WATER STREET MGP POUGHKEEPSIE, NY		SUBSURFACE STRUCTURES/OBSTRUCTIONS INVESTIGATION LOCATIONS	
DATE: 2/1/2018	NYSDEC SITE ID: 60540671	REMEDIAL DESIGN/REMEDIAL ACTION WORK PLAN	FIGURE 2-2

LEGEND

- | | | | |
|--|-----------------------------|--|--------------------------------------|
| | RAILWAY TRACKS | | NO NAPL |
| | GAS LINE | | MAXIMUM NAPL DEPTH 1' OR LESS |
| | ELECTRIC LINE | | MAXIMUM NAPL DEPTH BETWEEN 1' AND 3' |
| | FIBER OPTIC LINE | | MAXIMUM NAPL DEPTH BETWEEN 3' AND 7' |
| | OVERHEAD ELECTRIC LINE | | MAXIMUM NAPL DEPTH 7' OR MORE |
| | EDGE OF WALKWAY | | |
| | SITE BOUNDARY | | |
| | EXISTING FENCE | | |
| | EDGE OF WOODS | | |
| | LIMITS OF SEDIMENT DREDGING | | |

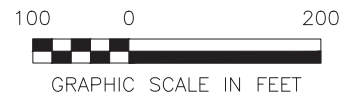
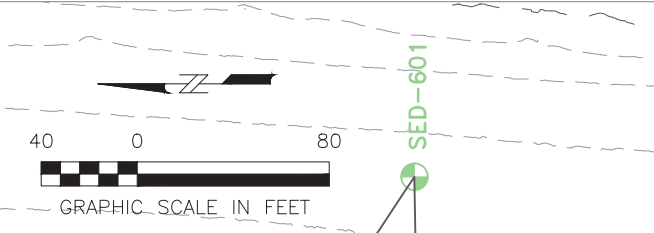
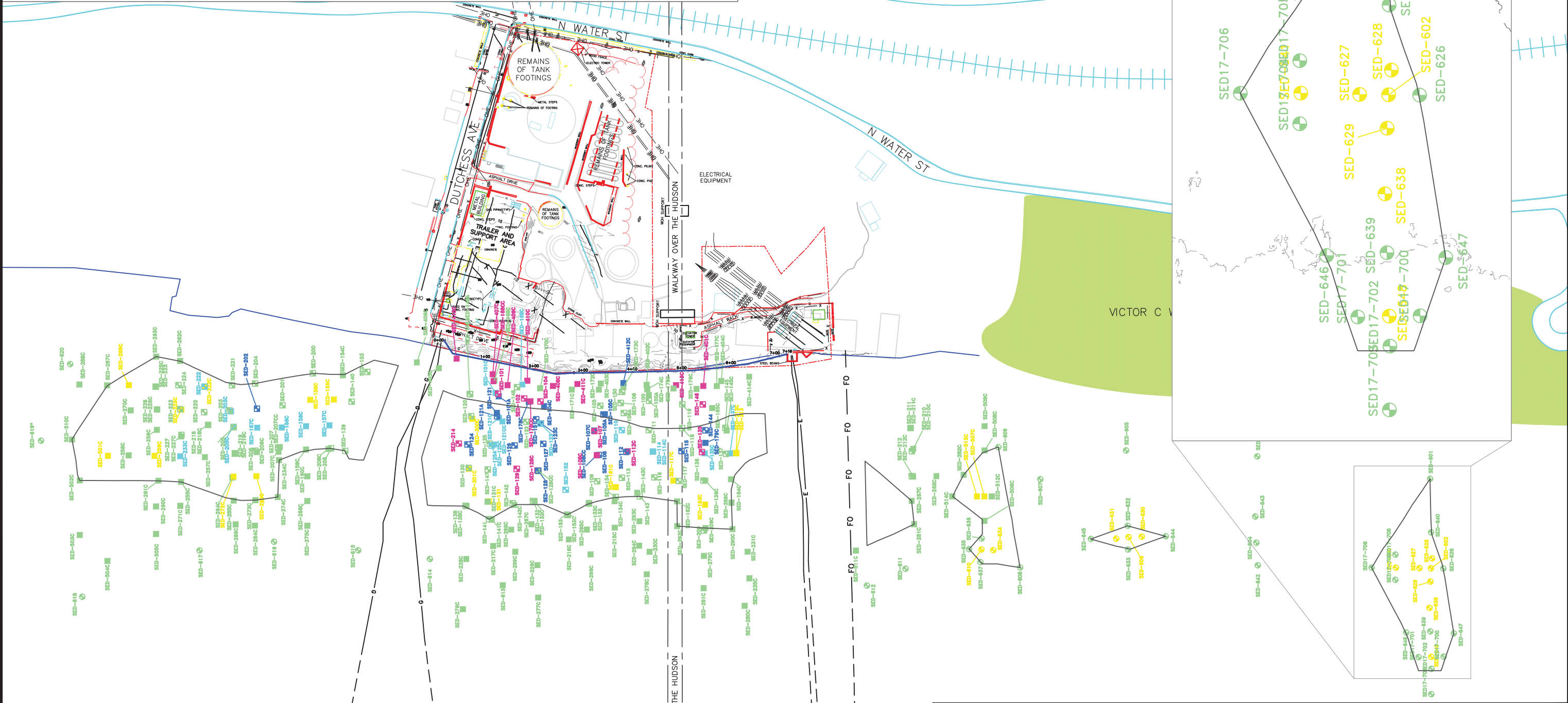

CENTRAL HUDSON GAS & ELECTRIC CORP.
FORMER NORTH WATER STREET MGP
 POUGHKEEPSIE, NY

SEDIMENT DREDGE LIMITS
DELINEATION SAMPLE LOCATIONS



File: P:\Jobs\Rem_Eng\Project Files\CHGE\900 CAD\910 CAD\20 SHEETS\RDRA Work Plan.dwg Layout: 2-4 User: erica.hart Plotted: Feb 01, 2018 - 8:48am Xref's:

LEGEND

- RAILWAY TRACKS
- GAS LINE
- ELECTRIC LINE
- FIBER OPTIC LINE
- OVERHEAD ELECTRIC LINE
- EDGE OF WALKWAY
- SITE BOUNDARY
- EXISTING FENCE
- EDGE OF WOODS
- PRE-CHARACTERIZATION BORING LOCATIONS
- LIMITS OF SEDIMENT DREDGING

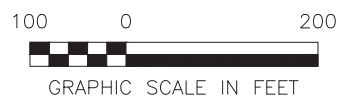

CENTRAL HUDSON GAS & ELECTRIC CORP.
FORMER NORTH WATER STREET MGP
POUGHKEEPSIE, NY

SEDIMENT DISPOSAL FACILITY
PRE-CHARACTERIZATION
SAMPLING LOCATIONS

DATE: 2/1/2018

NYSDEC SITE ID: 60540671

REMEDIAL DESIGN/REMEDIAL ACTION WORK PLAN

FIGURE 2-4

File: P:\Jobs\Rem_Eng\Project Files\CHGE\900 CAD\910 CAD\20 SHEETS\RDRA Work Plan.dwg Layout: 2-5 User: erica.hart Plotted: Feb 01, 2018 - 8:50am Xref's:

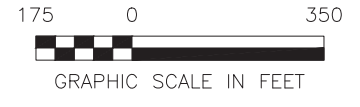
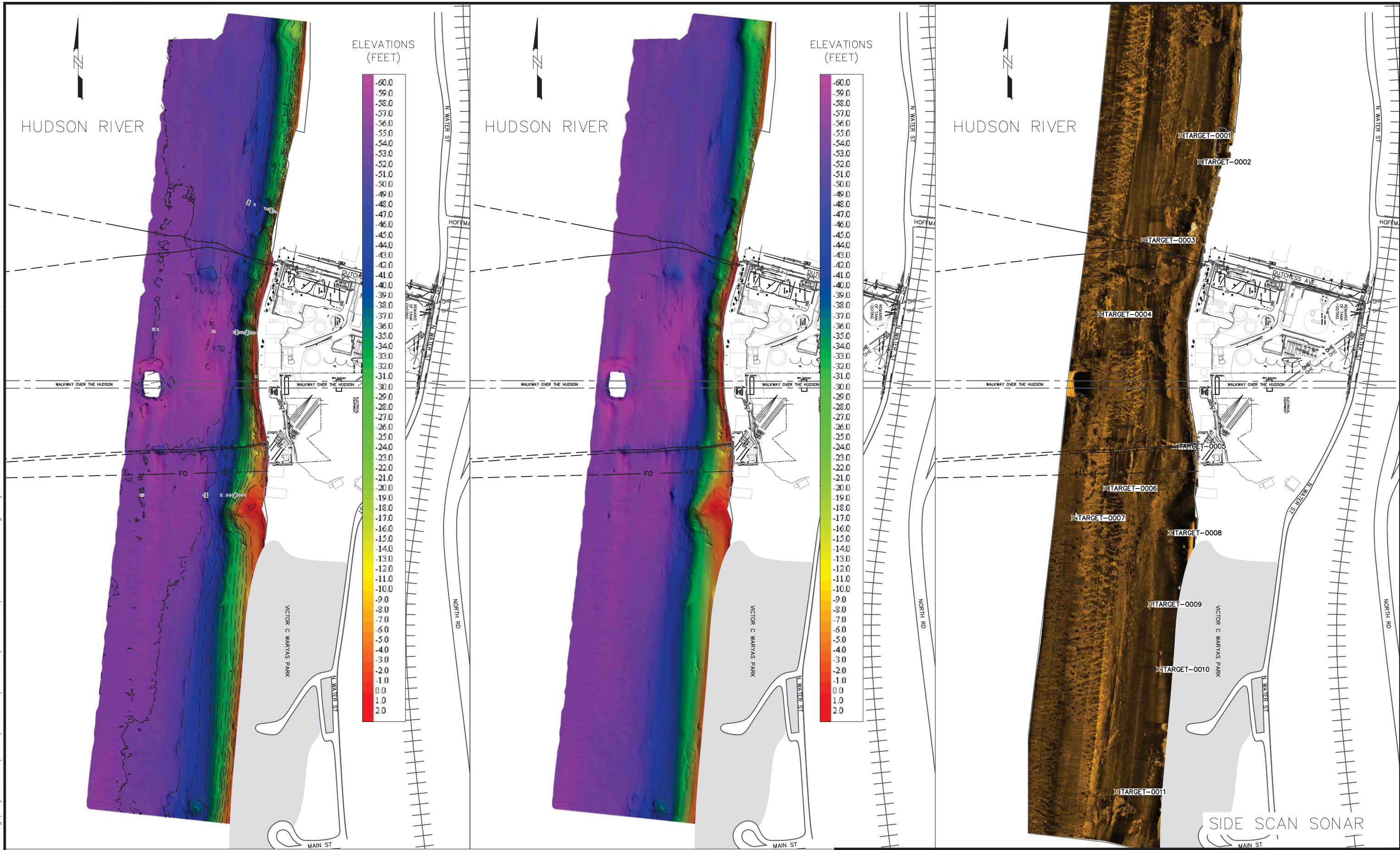















CENTRAL HUDSON GAS & ELECTRIC CORP.
FORMER NORTH WATER STREET MGP
POUGHKEEPSIE, NY

BATHYMETRIC SURVEY

File: P:\Jobs\Rem_Eng\Project Files\CHGE\900 CAD\910 CAD\20 SHEETS\RDRA Work Plan.dwg Layout: 3-1 User: erica.hart Plotted: Feb 01, 2018 - 12:02pm Xref's:

LEGEND

-  RAILWAY TRACKS
-  G — GAS LINE
-  E — ELECTRIC LINE
-  FO — FIBER OPTIC LINE
-  OHE — OVERHEAD ELECTRIC LINE
-  — — — EDGE OF WALKWAY
-  - - - - - SITE BOUNDARY
-  x — — — EXISTING FENCE
-  ~ ~ ~ ~ ~ EDGE OF WOODS
-  ~ ~ ~ ~ ~ BARRIER/BULKHEAD WALL
-  MW — — — MONITORING WELL
-  SF — — — SILT FENCE
-  □ — — — TURBIDITY CURTAIN
-  ■ — — — CONSTRUCTION RAMP

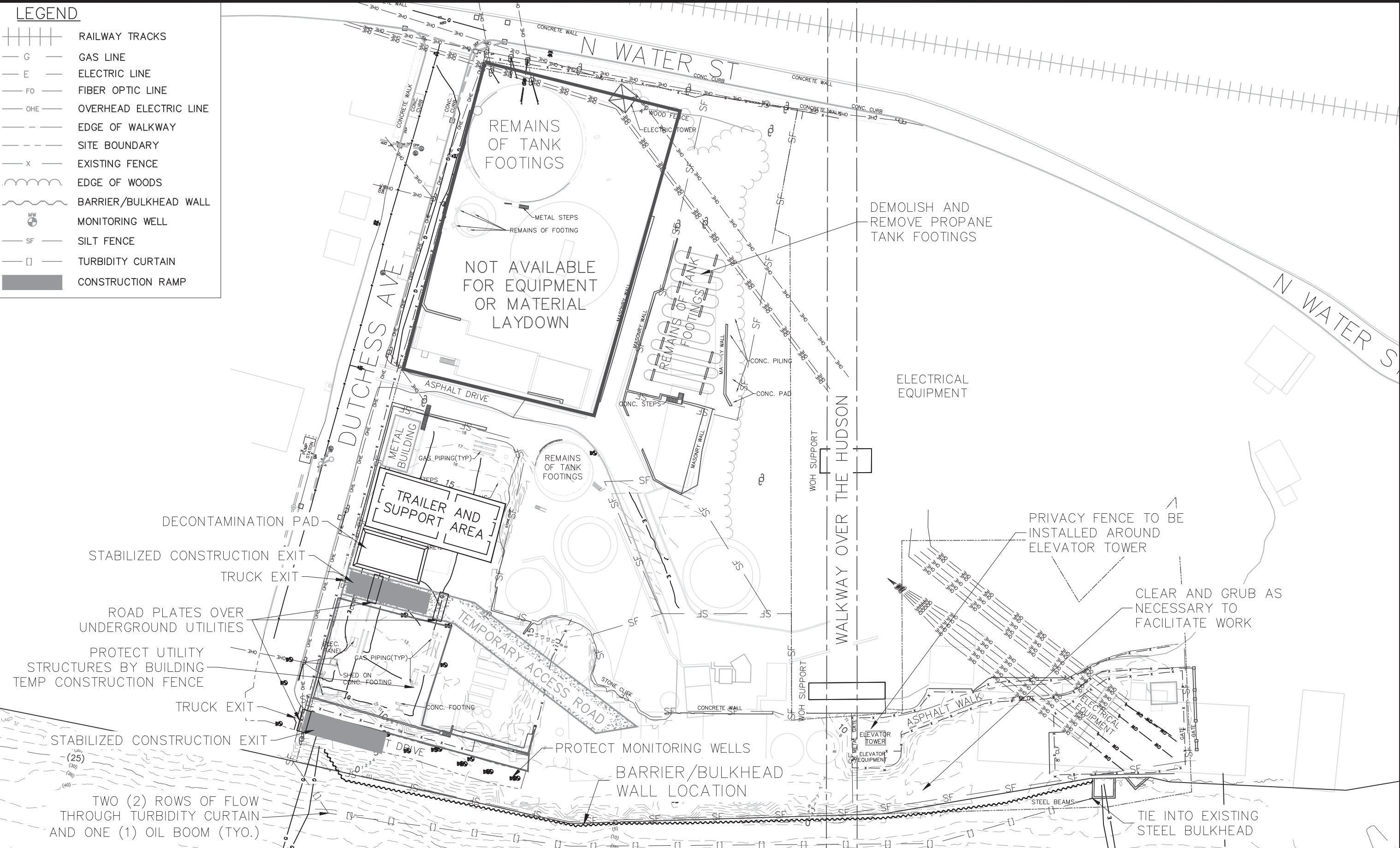

DECONTAMINATION PAD
 STABILIZED CONSTRUCTION EXIT
 TRUCK EXIT
 ROAD PLATES OVER UNDERGROUND UTILITIES
 PROTECT UTILITY STRUCTURES BY BUILDING TEMP CONSTRUCTION FENCE
 TRUCK EXIT
 STABILIZED CONSTRUCTION EXIT
 TWO (2) ROWS OF FLOW THROUGH TURBIDITY CURTAIN AND ONE (1) OIL BOOM (TYO.)

NOT AVAILABLE FOR EQUIPMENT OR MATERIAL LAYDOWN

DEMOLISH AND REMOVE PROPANE TANK FOOTINGS

PRIVACY FENCE TO BE INSTALLED AROUND ELEVATOR TOWER

CLEAR AND GRUB AS NECESSARY TO FACILITATE WORK

TIE INTO EXISTING STEEL BULKHEAD

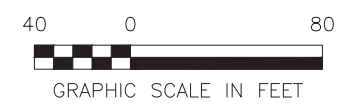

CENTRAL HUDSON GAS AND ELECTRIC CORP. FORMER NORTH WATER STREET MGP POUGHKEEPSIE, NY		SITE CONTROL MAP LANDSIDE CONSTRUCTION OPERATIONS	
DATE: 2/1/2018	NYSDEC SITE ID: 60540671	REMEDIAL DESIGN/REMEDIAL ACTION WORK PLAN	FIGURE 3-1

File: P:\Jobs\Rem_Eng\Project Files\CHGE\900 CAD\910 CAD\20 SHEETS\RDRA Work Plan.dwg Layout: 3-2 User: erica.hart Plotted: Feb 01, 2018 - 9:04am Xref's:

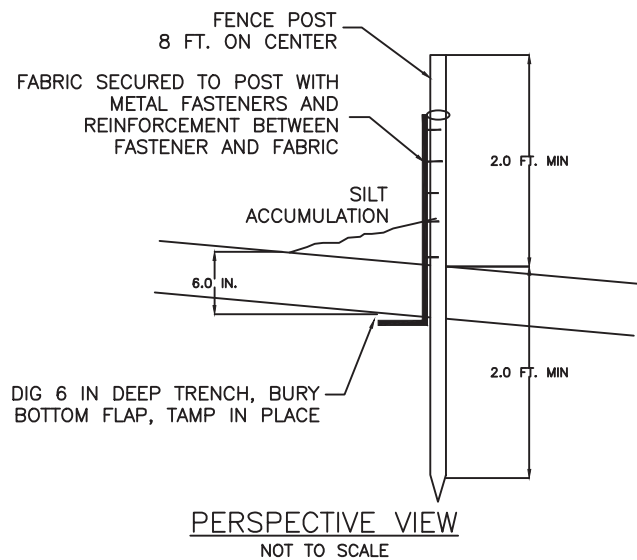
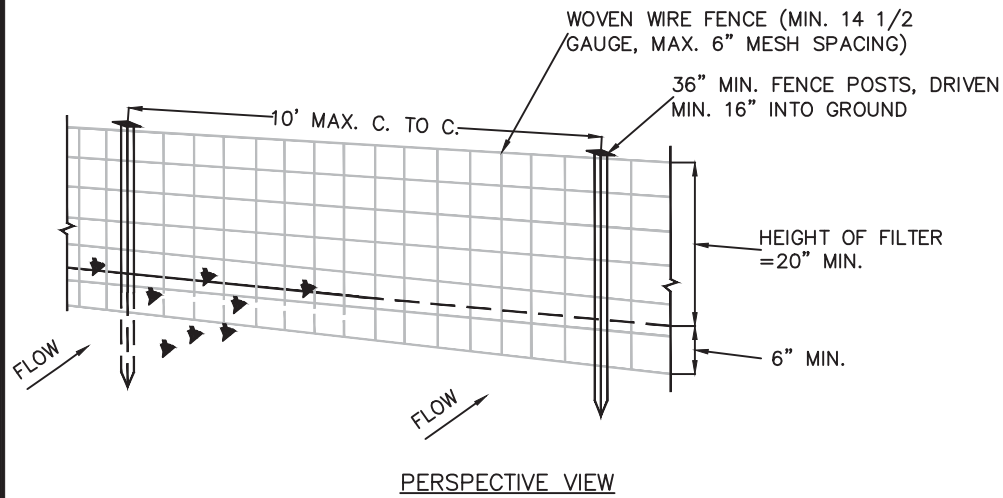

SILT FENCE NOTES:

1. WOVEN WIRE FENCE TO BE FASTENED SECURELY TO FENCE POSTS WITH WIRE TIES OR STAPLES
2. FILTER CLOTH TO BE FASTENED SECURELY TO WOVEN WIRE FENCE WITH TIES SPACED EVER 24" AT TOP AND MID SECTION
3. WHEN TWO SECTIONS OF FILTER CLOTH ADJOIN EACH OTHER THEY SHALL BE OVERLAPPED BY SIX INCHES AND FOLDED
4. MAINTENANCE SHALL BE PERFORMED AS NEEDED AND MATERIAL REMOVED WHEN "BULGES" DEVELOP IN THE SILT FENCE

POSTS:

1 1/4" X 1 1/4" HARDWOOD

FENCE:

WOVEN WIRE, 14 1/2 GA. 6" MAX. MESH OPENING

FILTER CLOTH:

FILTER X. MIRAFI 100X. STABILINKA T140N OR APPROVED EQUAL

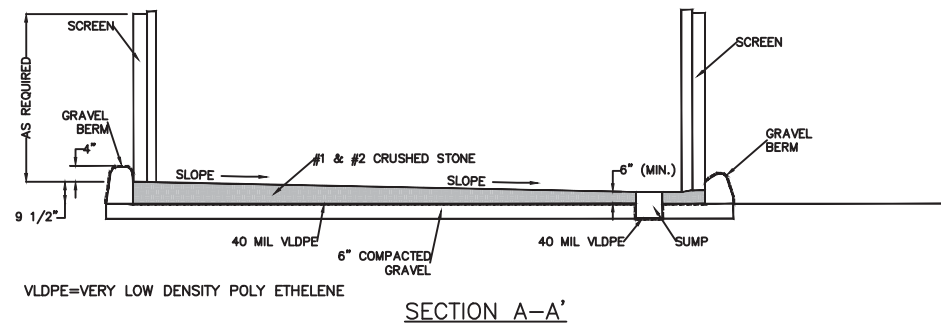
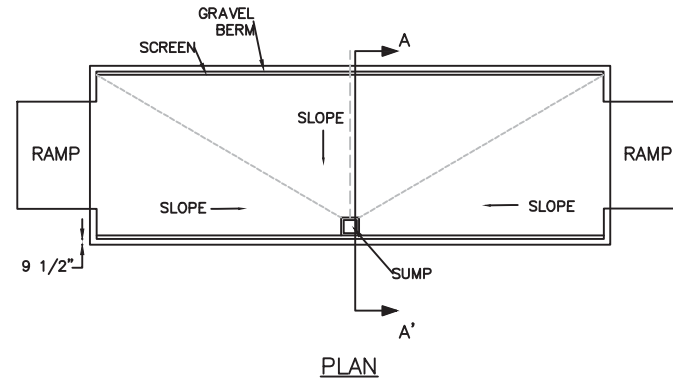

EQUIPMENT CONTAMINATION REDUCTION PAD
 NOT TO SCALE

DECONTAMINATION PAD NOTES:

1. A SUBMERSIBLE PUMP WILL BE PLACED IN SUMP AS REQUIRED. THE PUMP WILL TRANSPORT WASTEWATER VIA HOSE OR PORTABLE CONTAINER TO PROJECT WATER TREATMENT SYSTEM.

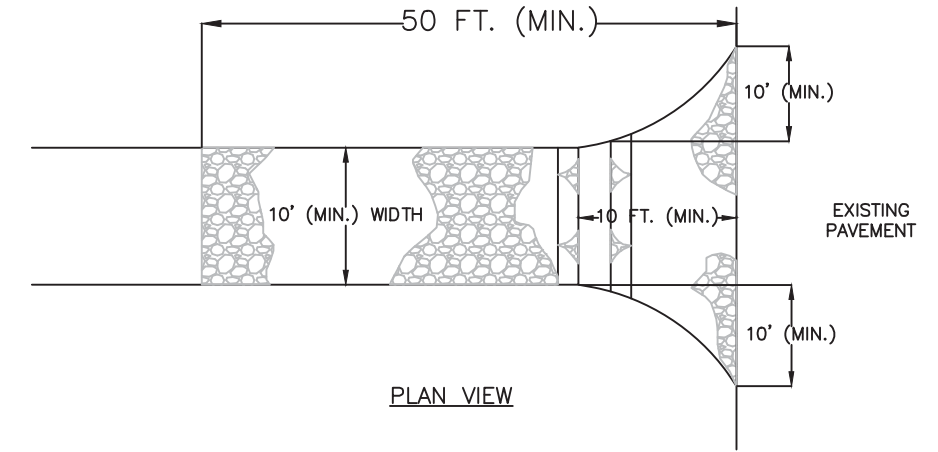
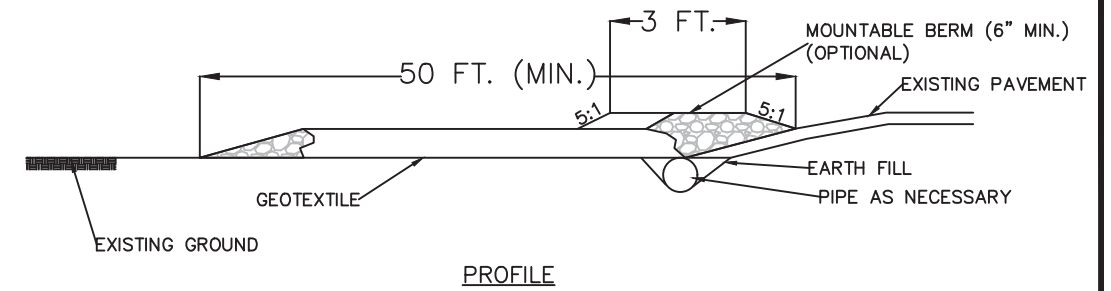
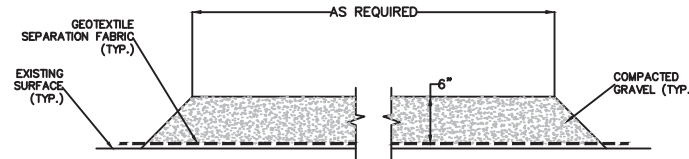

STABILIZED CONSTRUCTION ENTRANCE
 NOT TO SCALE

STABILIZED CONSTRUCTION ENTRANCE NOTES:

1. STONE SIZE - USE 1-4 INCH STONE, OR RECLAIMED OR RECYCLED CONCRETE
2. LENGTH - NOT LESS THAN 50 FT
3. THICKNESS - NOT LESS THAN 6 INCHES
4. WIDTH - 12 FT. MINIMUM, BUT NO LESS THAN THE FULL WIDTH AT POINTS WHERE INGRESS OR REGRESS OCCURS, 24 FT. MINIMUM IF SINGLE ENTRANCE TO SITE
5. GEOTEXTILE (MIN. 8 OZ./SY) - WILL BE PLACED OVER THE ENTIRE AREA PRIOR TO PLACING STONE
6. SURFACE WATER - ALL SURFACE WATER FLOWING OR DIVERTED TOWARD CONSTRUCTION ENTRANCES SHALL BE PIPED BENEATH THE ENTRANCE. IF PIPING IS IMPRACTICAL, A MOUNTABLE BERM WITH 5:1 SLOPE WILL BE PERMITTED
7. MAINTENANCE - THE ENTRANCE SHALL BE MAINTAINED IN A CONDITION WHICH WILL PREVENT TRACKING OR FLOWING OF SEDIMENT ONTO THE PUBLIC RIGHTS-OF-WAY OR ADJACENT PRIVATE, ALL SEDIMENT SPILLED, DROPPED, WASHED OR TRACKED ONTO THESE AREAS SHALL BE REMOVED IMMEDIATELY
8. WHEN WASHING IS REQUIRED, IT SHALL BE DONE ON AN AREA STABILIZED WITH STONE AND WHICH DRAINS INTO AN APPROVED SEDIMENT TRAPPING DEVICE
9. PERIODIC INSPECTION AND NEEDED MAINTENANCE SHALL BE PROVIDED AFTER EACH RAIN EVENT



CENTRAL HUDSON GAS AND ELECTRIC CORP.
 FORMER NORTH WATER STREET MGP
 POUGHKEEPSIE, NY

SITE CONTROL DETAILS

DATE: 2/1/2018

NYSDEC SITE ID: 60540671

REMEDIAL DESIGN/REMEDIAL ACTION WORK PLAN

FIGURE 3-2

File: P:\Jobs\Rem_Eng\Project Files\CHGE\900 CAD\20 SHEETS\C-101 to C-106, C-113.dwg Layout: 3-3 User: sirventij Plotted: Aug 01, 2018 - 11:32am Xref's:

LEGEND

— [] — TURBIDITY CURTAIN

NOTES:

1. INSTALL TURBIDITY CURTAINS DURING RIVER SLOPE GRADING WORK.
2. INSTALL TURBIDITY CURTAINS DURING DREDGE WORK. LOCATIONS APPROXIMATE.
3. EXCLUSION AREAS WILL BE DELINEATED WITH BUOYS WITH LIGHTS, AT A MINIMUM EVERY 250'.
4. EXCLUSION AREA IS SUBJECT TO CHANGE DEPENDING ON WORK ACTIVITY

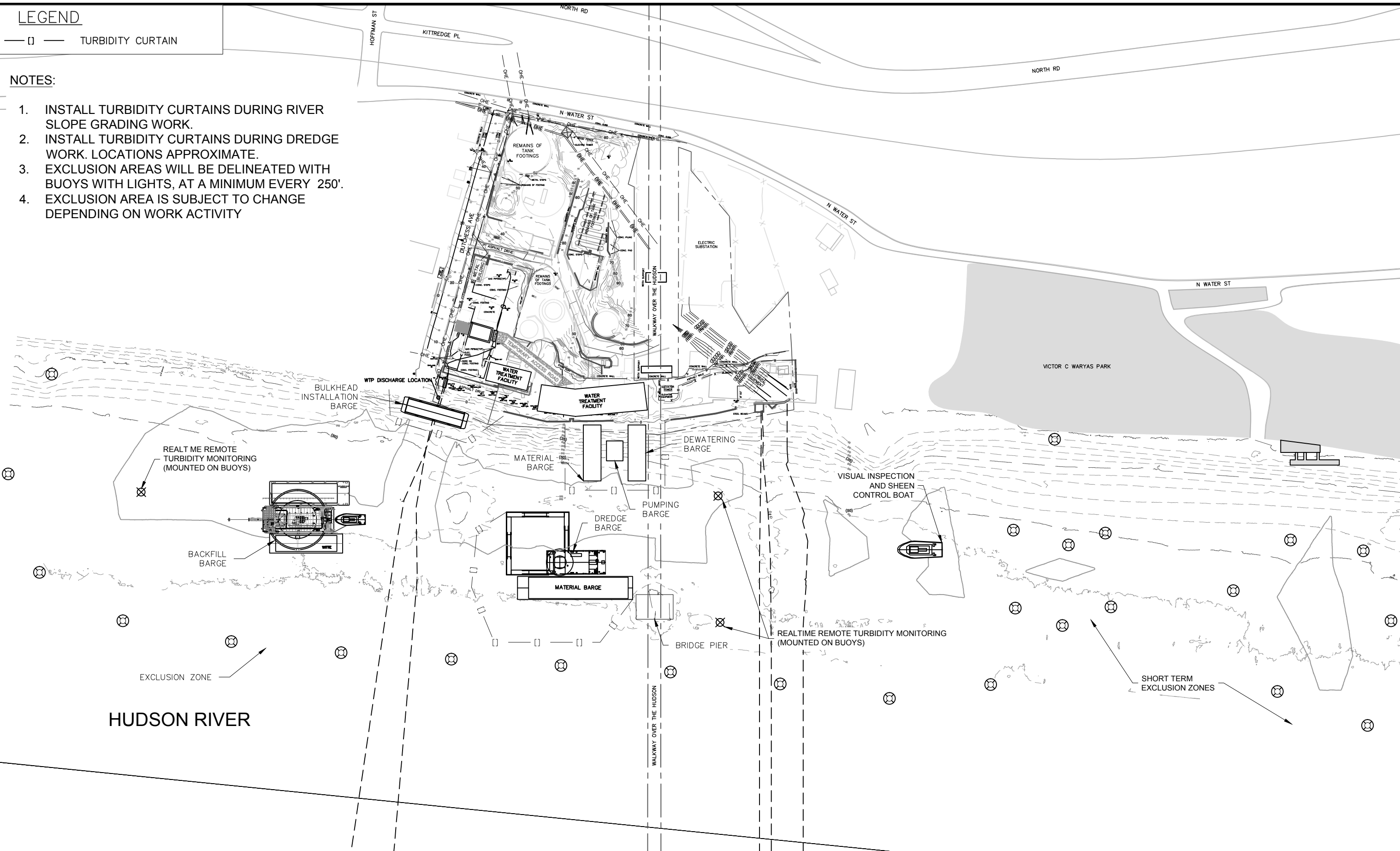

CENTRAL HUDSON GAS & ELECTRIC CORP.
 FORMER NORTH WATER STREET MGP
 POUGHKEEPSIE, NY

SITE CONTROL MAP
WATERSIDE CONSTRUCTION OPERATIONS

File: P:\Jobs\Rem_Eng\Project Files\CHGE\900 CAD\910 CAD\20 SHEETS\RDRA Work Plan.dwg Layout: 3-4 User: erica.hart Plotted: Feb 01, 2018 - 9:06am Xrefs:

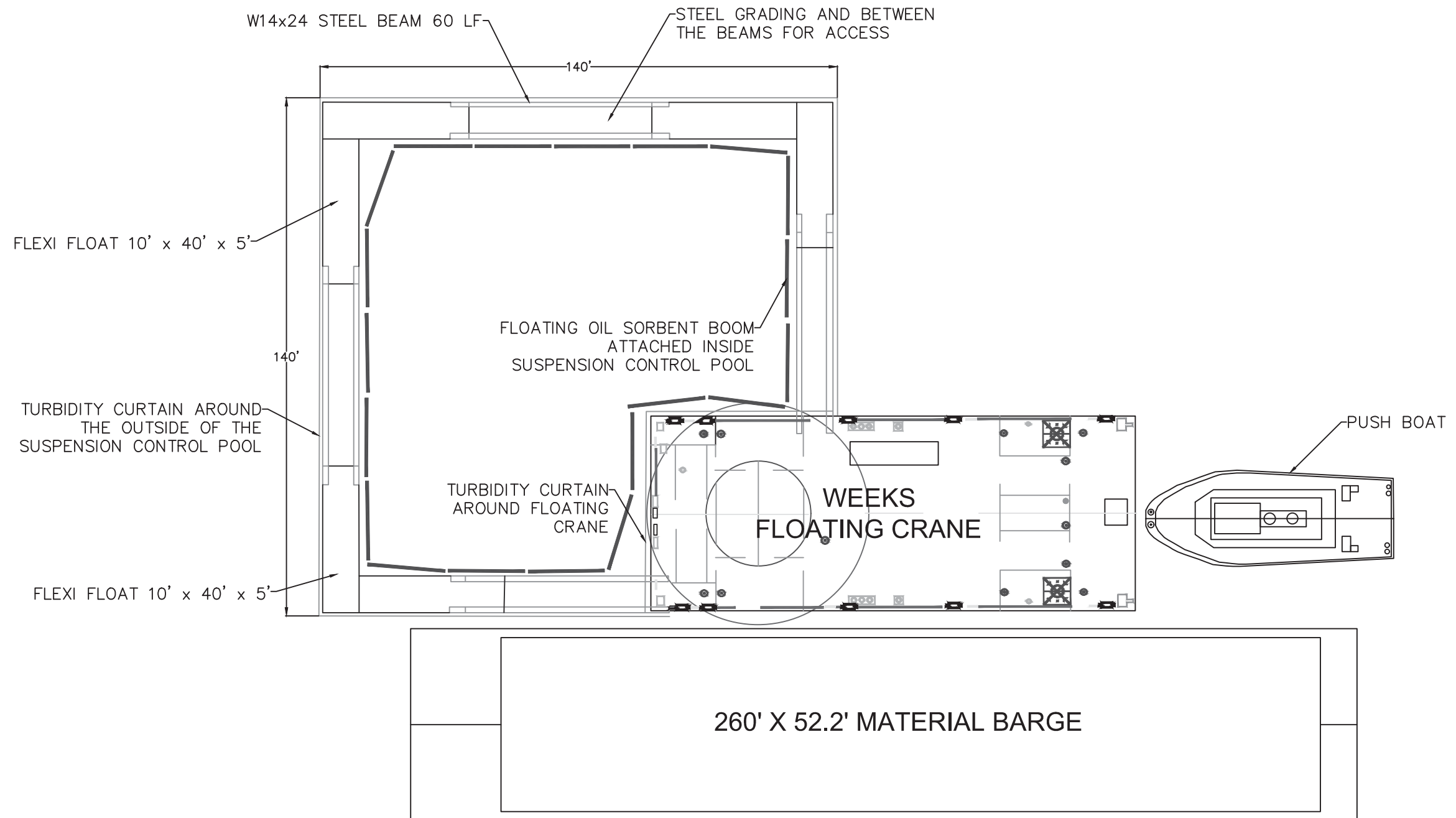

MOBILE SUSPENSION CONTROL SYSTEM SETUP OVERVIEW

NOTE: FIGURES NOT DRAWN TO SCALE. THESE ARE CONCEPTUAL DRAWINGS.



CENTRAL HUDSON GAS & ELECTRIC CORP.
FORMER NORTH WATER STREET MGP
POUGHKEEPSIE, NY

SEDIMENT DREDGE CONTAINMENT
CELL PLAN VIEW

DATE: 2/1/2018

NYSDEC SITE ID: 60540671

REMEDIAL DESIGN/REMEDIAL ACTION WORK PLAN

FIGURE 3-4

File: P:\Jobs\Rem_Eng\Project Files\CHGE\900 CAD\910 CAD\20 SHEETS\RDRA Work Plan.dwg Layout: 3-5 User: erica.hart Plotted: Feb 01, 2018 - 9:07am Xrefs:

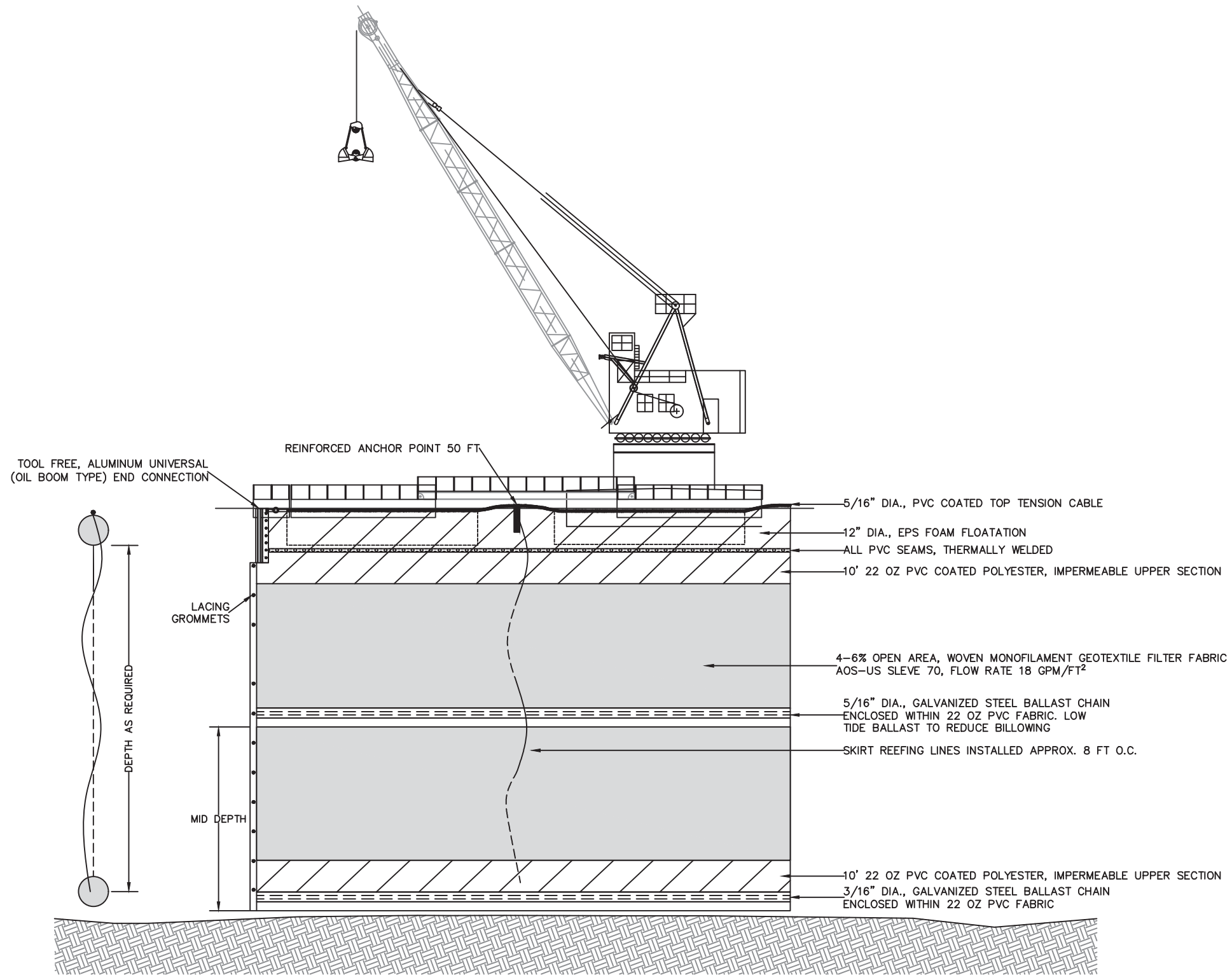

SEDIMENT DREDGE CONTAINMENT

NOTE: FIGURES NOT DRAWN TO SCALE. THESE ARE CONCEPTUAL DRAWINGS.



CENTRAL HUDSON GAS & ELECTRIC CORP.
FORMER NORTH WATER STREET MGP
POUGHKEEPSIE, NY

**SEDIMENT DREDGE CONTAINMENT
CELL SIDE VIEW**

DATE: 2/1/2018

NYSDEC SITE ID: 60540671

REMEDIAL DESIGN/REMEDIAL ACTION WORK PLAN

FIGURE 3-5

File: P:\Jobs\Rem_Eng\Project Files\CHGE\900 CAD\910 CAD\20 SHEETS\RDRA Work Plan.dwg Layout: 3-7 User: erica.hart Plotted: Feb 01, 2018 - 2:19pm Xref's:

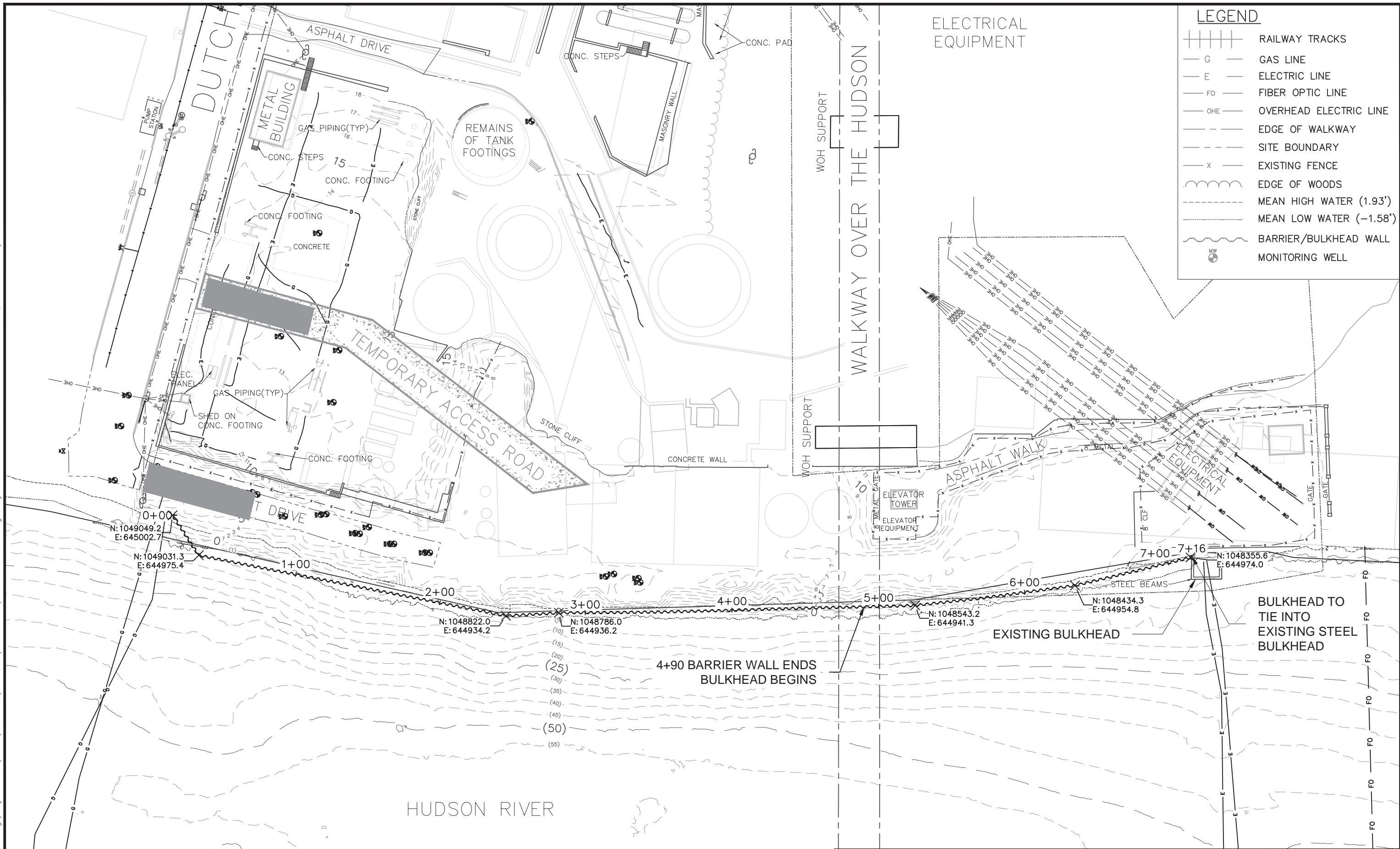

LEGEND	
	RAILWAY TRACKS
	GAS LINE
	ELECTRIC LINE
	FIBER OPTIC LINE
	OVERHEAD ELECTRIC LINE
	EDGE OF WALKWAY
	SITE BOUNDARY
	EXISTING FENCE
	EDGE OF WOODS
	MEAN HIGH WATER (1.93')
	MEAN LOW WATER (-1.58')
	BARRIER/BULKHEAD WALL
	MONITORING WELL

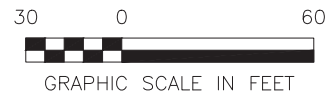

CENTRAL HUDSON GAS & ELECTRIC CORP. FORMER NORTH WATER STREET MGP POUGHKEEPSIE, NY		BARRIER/BULKHEAD WALL ALIGNMENT	
DATE: 2/1/2018	NYSDEC SITE ID: 60540671	REMEDIAL DESIGN/REMEDIAL ACTION WORK PLAN	FIGURE 3-7

File: P:\Jobs\Rem_Eng\Project Files\CHGE\900 CAD\910 CAD\20 SHEETS\CHGE Profile.dwg Layout: 3-8 User: siverij Plotted: Aug 01, 2018 - 10:49am Xref's:

PROPOSED STEEL BULKHEAD

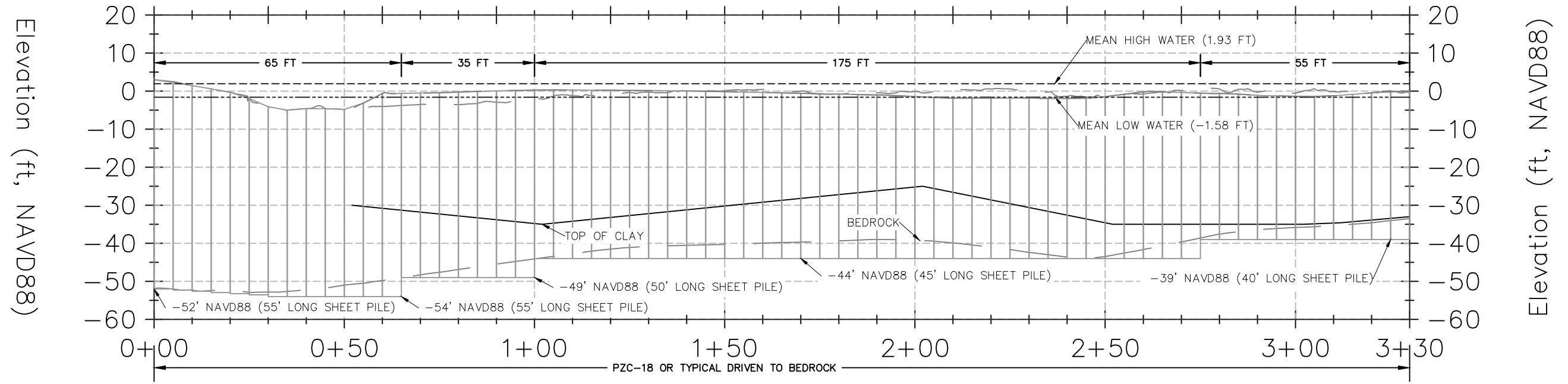

PROPOSED STEEL BULKHEAD

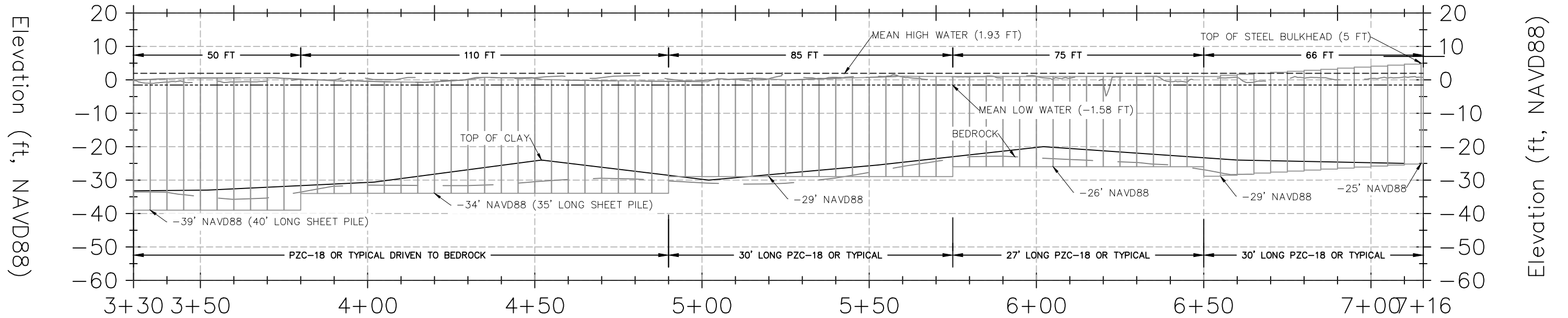

LEGEND

- MEAN HIGH WATER (1.93')
- MEAN LOW WATER (-1.58')



PZC-18 STEEL SHEET PILE

NOTES:

1. TOP OF CLAY AND TOP OF BEDROCK ELEVATIONS ARE APPROXIMATE AND FOR INFORMATIONAL PURPOSES ONLY.
2. TOP OF WALL WILL BE CUT TO MEAN LOW TIDE ELEVATION TO THE EXTENT POSSIBLE AND/OR COVERED WITH RIP-RAP.



CENTRAL HUDSON GAS & ELECTRIC CORP.
FORMER NORTH WATER STREET MGP
POUGHKEEPSIE, NY

**BARRIER/BULKHEAD WALL
PROFILE VIEW**

File: P:\Jobs\Rem_Eng\Project Files\CHGE\900 CAD\910 CAD\20 SHEETS\C-107 to C-112, C-114, C-201.dwg Layout: 3-9 User: sriventij Plotted: Jul 31, 2018 - 10:35am Xref's:

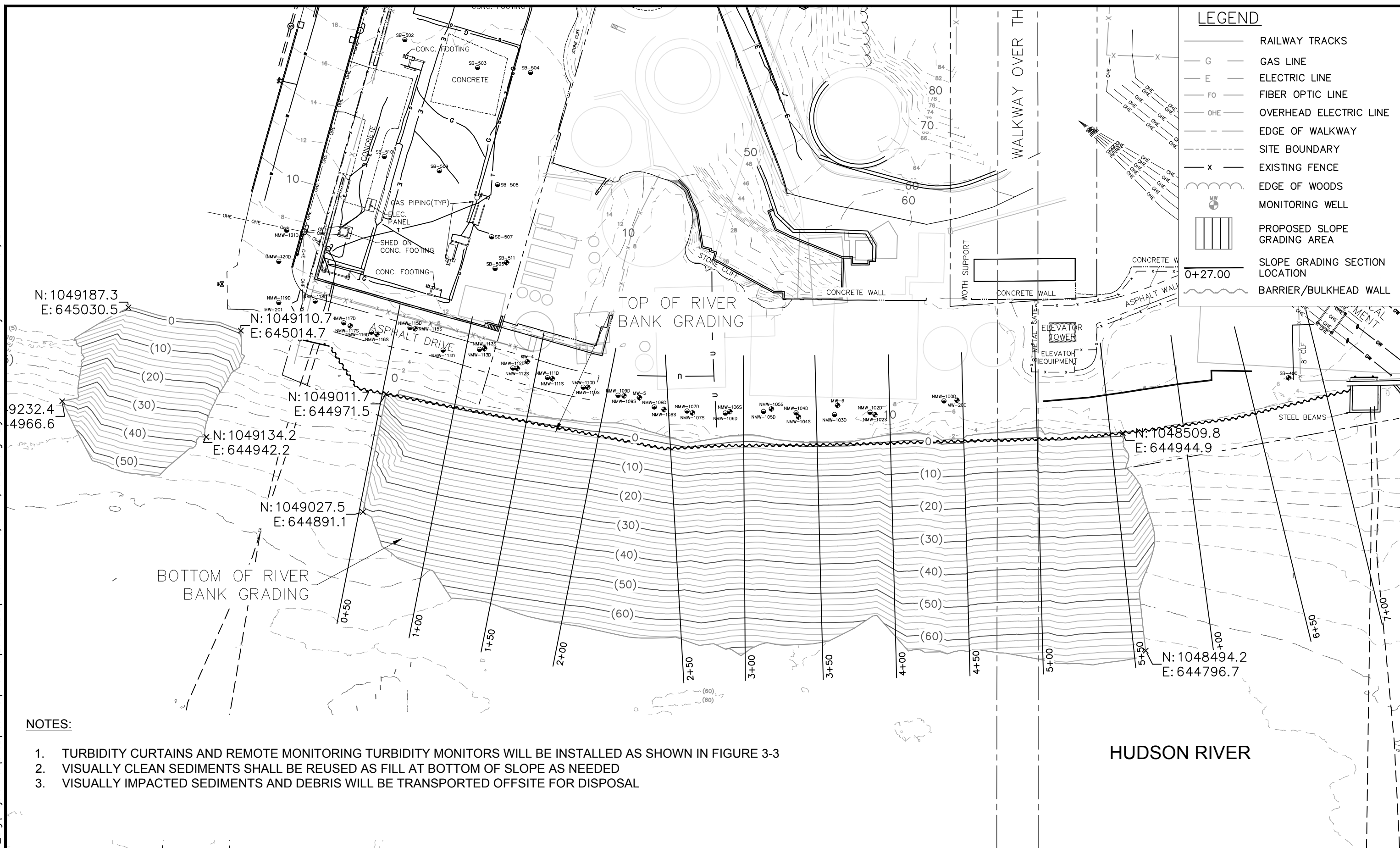

LEGEND	
	RAILWAY TRACKS
	GAS LINE
	ELECTRIC LINE
	FIBER OPTIC LINE
	OVERHEAD ELECTRIC LINE
	EDGE OF WALKWAY
	SITE BOUNDARY
	EXISTING FENCE
	EDGE OF WOODS
	MONITORING WELL
	PROPOSED SLOPE GRADING AREA
	SLOPE GRADING SECTION LOCATION
	BARRIER/BULKHEAD WALL

N: 1049187.3
E: 645030.5

N: 1049110.7
E: 645014.7

N: 1049011.7
E: 644971.5

N: 1049134.2
E: 644942.2

N: 1049027.5
E: 644891.1

N: 1048509.8
E: 644944.9

N: 1048494.2
E: 644796.7

- NOTES:
1. TURBIDITY CURTAINS AND REMOTE MONITORING TURBIDITY MONITORS WILL BE INSTALLED AS SHOWN IN FIGURE 3-3
 2. VISUALLY CLEAN SEDIMENTS SHALL BE REUSED AS FILL AT BOTTOM OF SLOPE AS NEEDED
 3. VISUALLY IMPACTED SEDIMENTS AND DEBRIS WILL BE TRANSPORTED OFFSITE FOR DISPOSAL

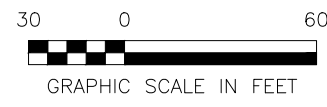
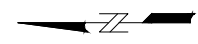

CENTRAL HUDSON GAS & ELECTRIC CORP. FORMER NORTH WATER STREET MGP POUGHKEEPSIE, NY		RIVER SLOPE GRADING PLAN	
DATE: 7/31/2018	NYSDEC SITE ID: 60540671	REMEDIAL DESIGN/REMEDIAL ACTION WORK PLAN	FIGURE 3-9

File: P:\Jobs\Rem_Eng\Project Files\CHGE\900 CAD\910 CAD\20 SHEETS\Conceptual Wall Design - 8-01-18.dwg Layout: 3-10A User: sirventj Plotted: Aug 01, 2018 - 11:07am Xref's:

LEGEND

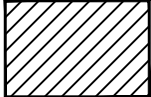
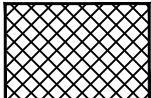
- ORIGINAL SLOPE SURFACE
- RESTORED CAP SURFACE
- - - - - DREDGE SURFACE
- MEAN HIGH WATER (1.93')
- MEAN LOW WATER (-1.58')
-  CLAY
-  BEDROCK

NOTES:

1. REGRADE SLOPE IS 2H:1V THROUGHOUT.
2. DEBRIS FROM THE SLOPE WILL BE REMOVED AND SENT OFFSITE FOR DISPOSAL.
3. VISUALLY CLEAN FILL REMOVED DURING GRADING WILL BE REUSED AS BACKFILL DURING REGRADING FILL ACTIVITIES.
4. TOP OF WALL WILL BE CUT TO MEAN LOW TIDE ELEVATION TO THE EXTENT POSSIBLE AND/OR COVERED WITH RIP-RAP.

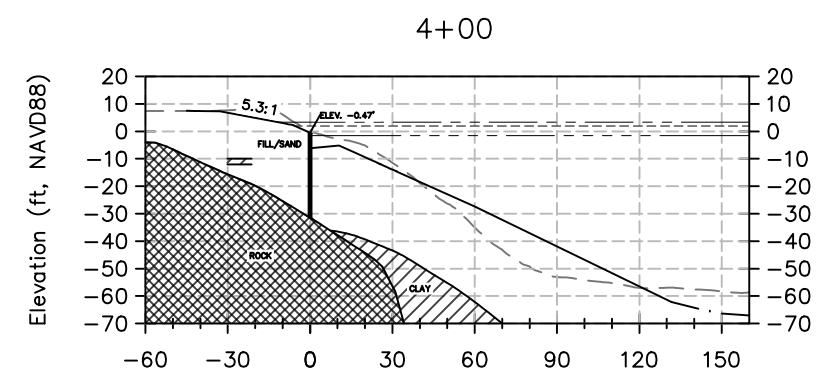
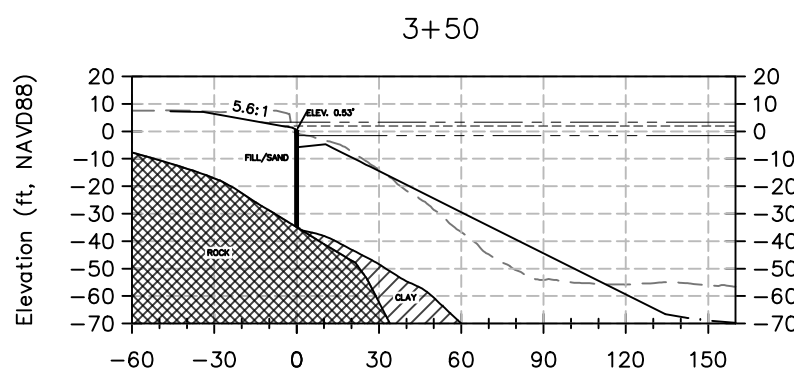
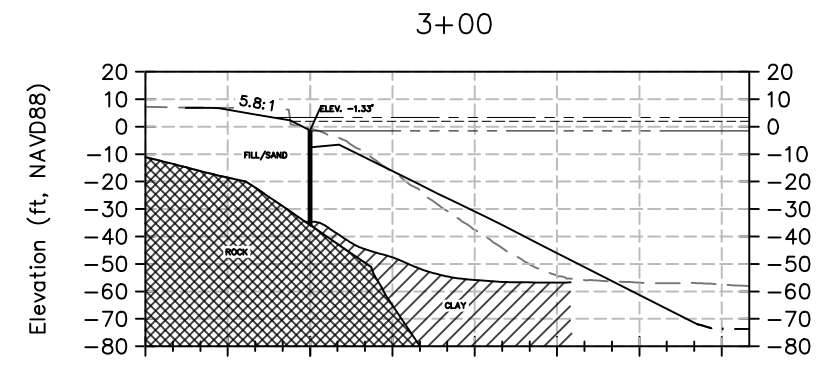
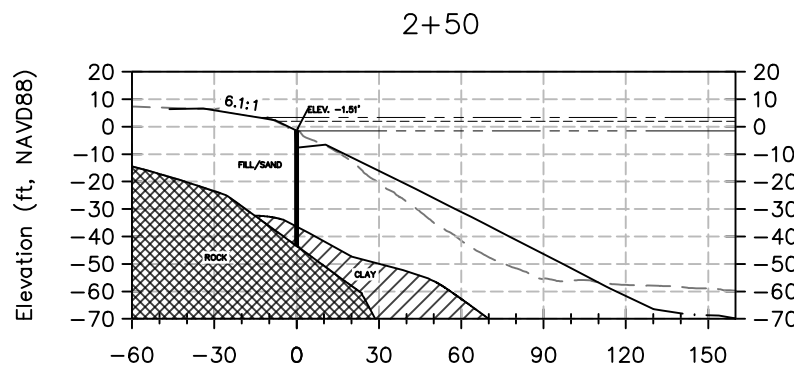
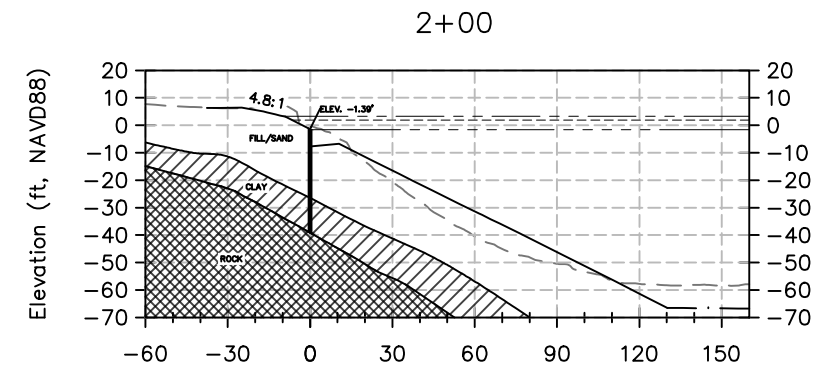
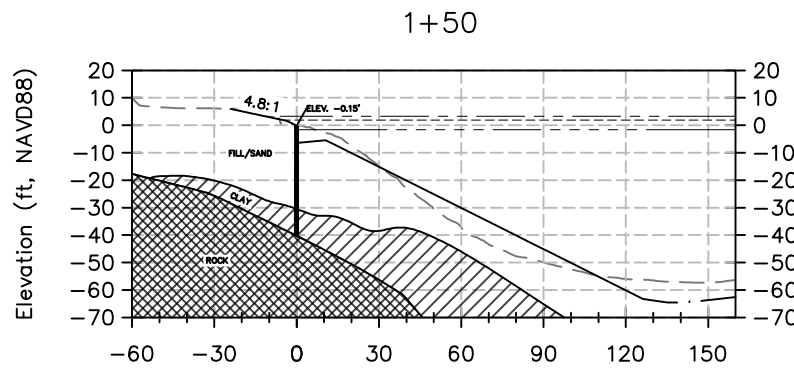
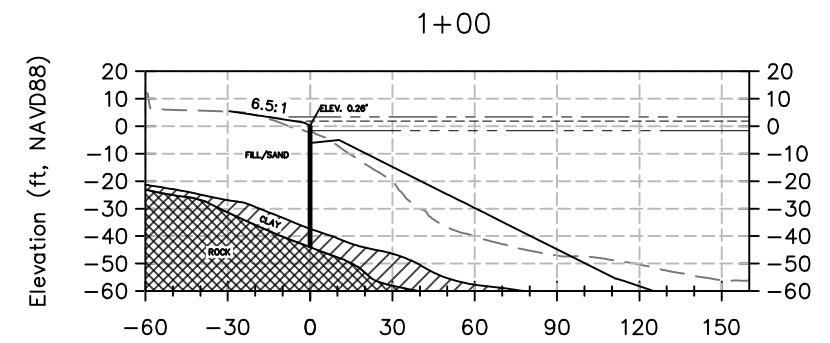
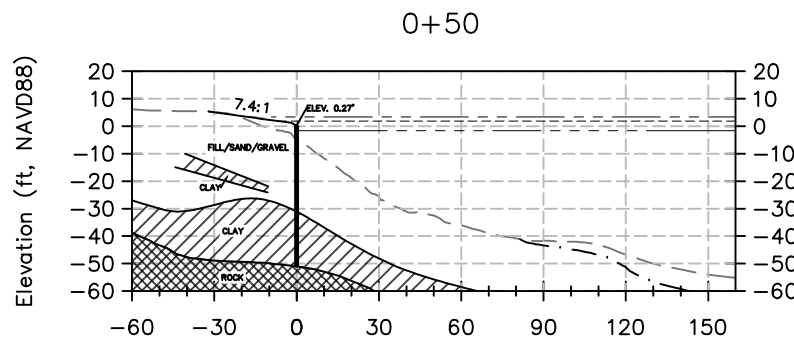

CENTRAL HUDSON GAS & ELECTRIC CORP.
FORMER NORTH WATER STREET MGP
POUGHKEEPSIE, NY

RIVER SLOPE GRADING
CROSS SECTIONS

File: P:\Jobs\Rem_Eng\Project Files\CHGE\900 CAD\910 CAD\20 SHEETS\Conceptual Wall Design - 8-01-18.dwg Layout: 3-10B User: sirventj Plotted: Aug 01, 2018 - 11:04am Xref's:

LEGEND

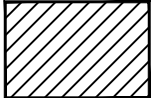
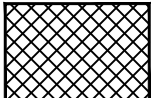
- ORIGINAL SLOPE SURFACE
- RESTORED CAP SURFACE
- DREDGE SURFACE
- MEAN HIGH WATER (1.93')
- MEAN LOW WATER (-1.58')
-  CLAY
-  BEDROCK

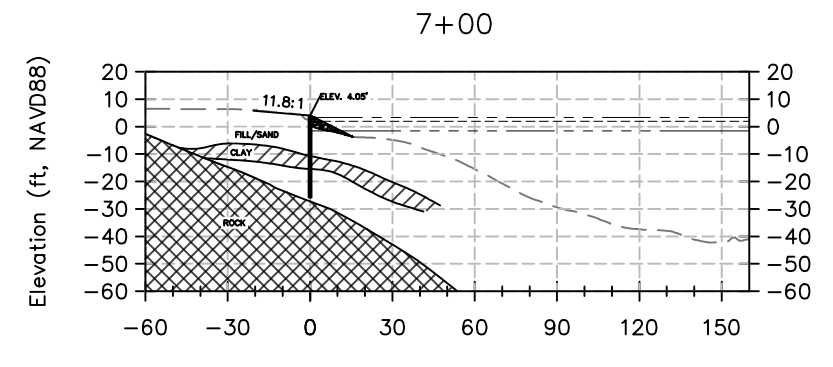
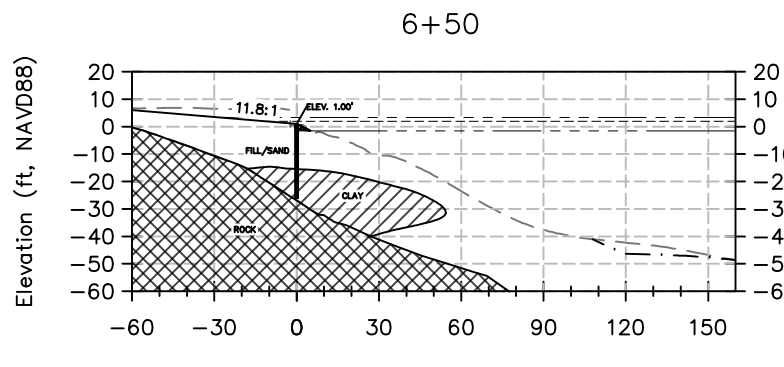
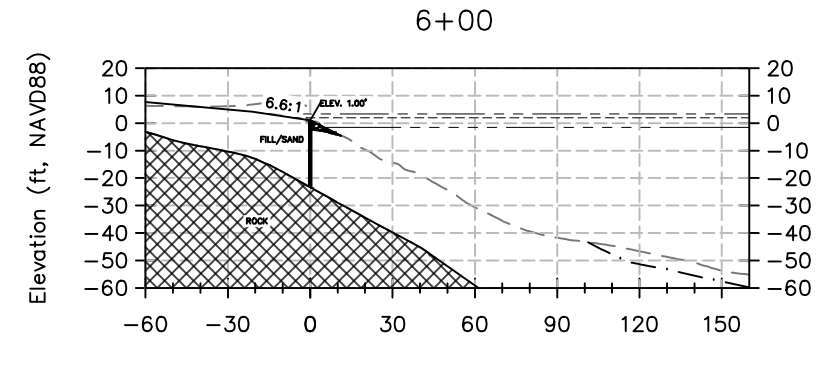
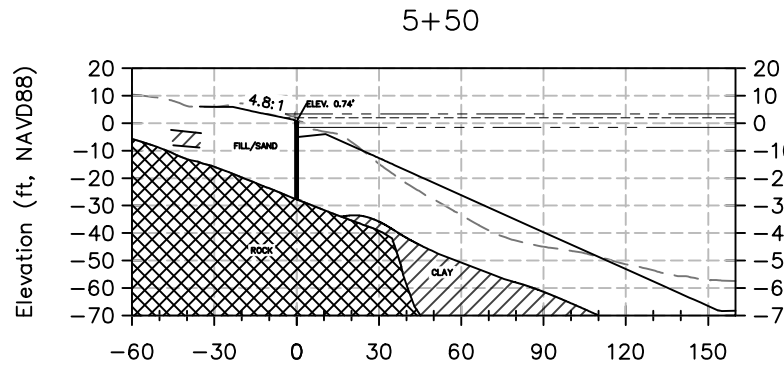
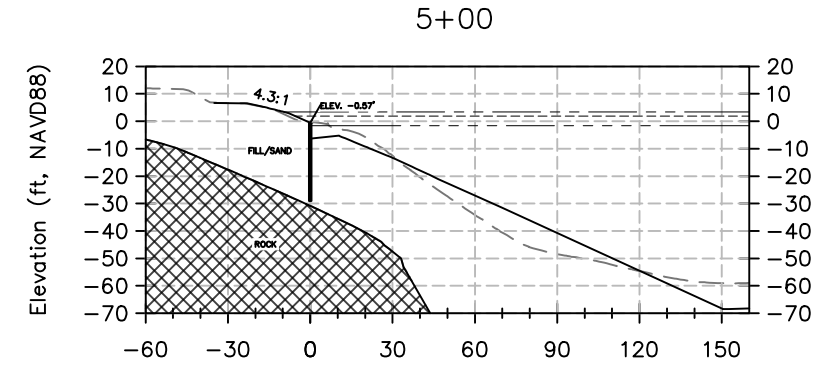
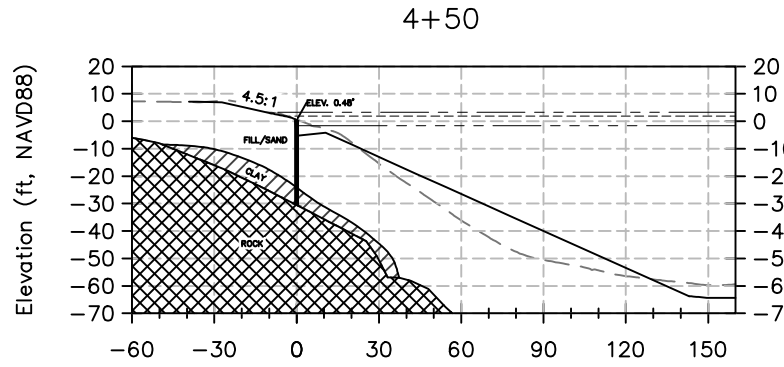

NOTES:

1. REGRADE SLOPE IS 2H:1V THROUGHOUT.
2. DEBRIS FROM THE SLOPE WILL BE REMOVED AND SENT OFFSITE FOR DISPOSAL.
3. VISUALLY CLEAN FILL REMOVED DURING GRADING WILL BE REUSED AS BACKFILL DURING REGRADING FILL ACTIVITIES.
4. TOP OF WALL WILL BE CUT TO MEAN LOW TIDE ELEVATION TO THE EXTENT POSSIBLE AND/OR COVERED WITH RIP-RAP.



CENTRAL HUDSON GAS & ELECTRIC CORP.
FORMER NORTH WATER STREET MGP
POUGHKEEPSIE, NY

RIVER SLOPE GRADING
CROSS SECTIONS

DATE: 8/01/2018

NYSDEC SITE ID: 60540671



REMEDIAL DESIGN/REMEDIAL ACTION WORK PLAN

FIGURE 3-10B

File: P:\Jobs\Rem_Eng\Project Files\CHGE\900 CAD\910 CAD\20 SHEETS\RDRA Work Plan.dwg Layout: 3-11 User: erica.hart Plotted: Feb 01, 2018 - 9:17am Xref's:



LEGEND

-  DREDGE PRISM
-  DREDGE PRISM NUMBER
-  DREDGE THICKNESS

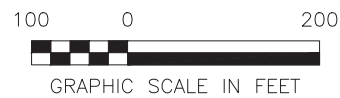

CENTRAL HUDSON GAS & ELECTRIC CORP.
FORMER NORTH WATER STREET MGP
POUGHKEEPSIE, NY

RIVER SEDIMENT DREDGE PLAN

DATE: 2/1/2018

NYSDEC SITE ID: 60540671

REMEDIAL DESIGN/REMEDIAL ACTION WORK PLAN

FIGURE 3-11

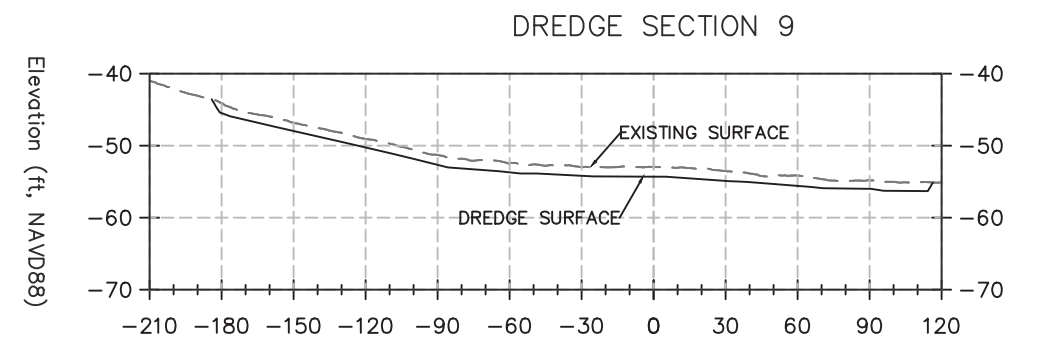
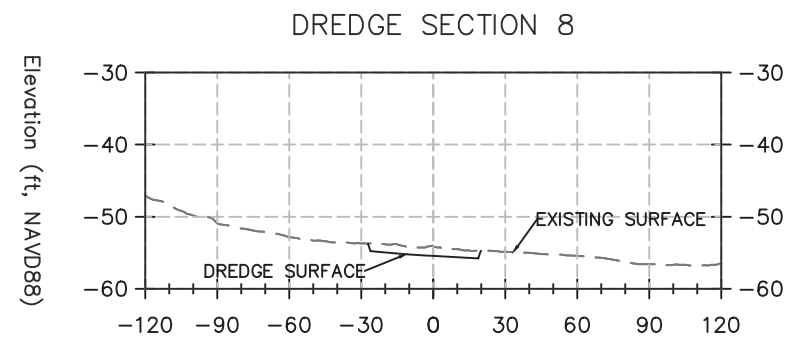
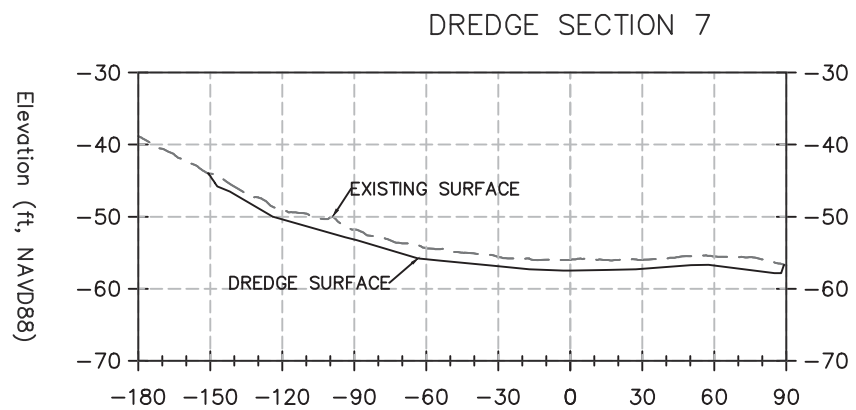
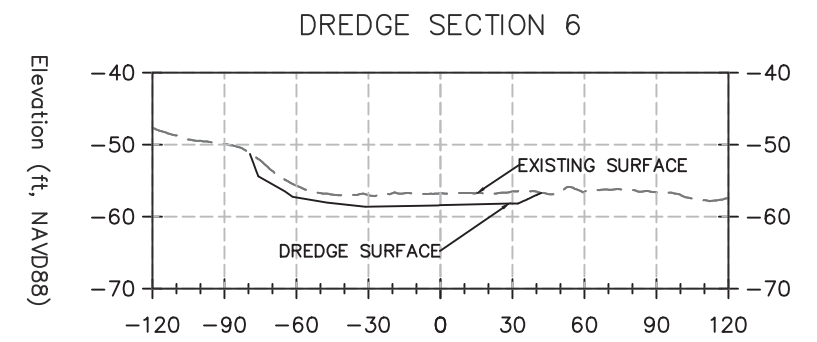
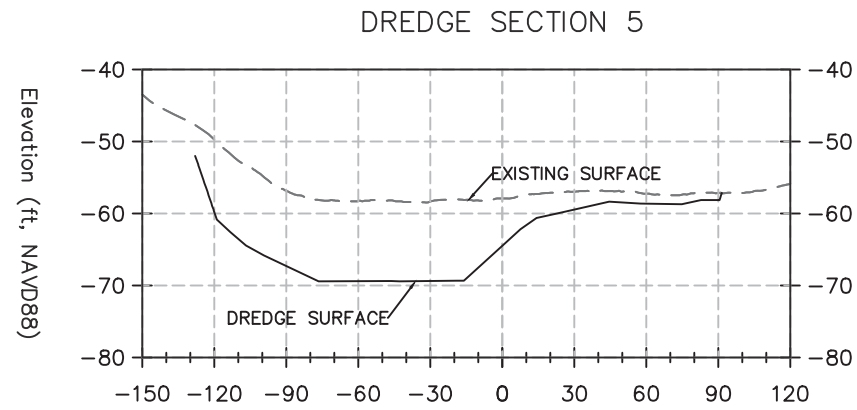
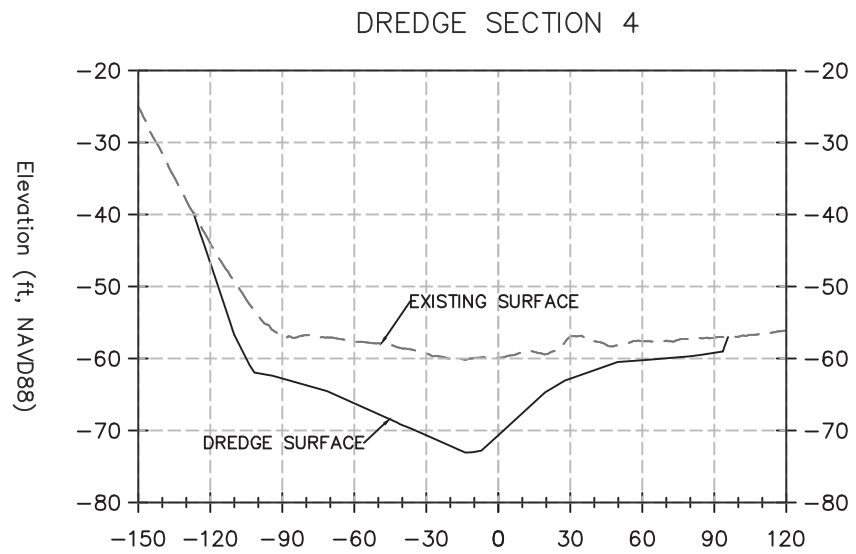
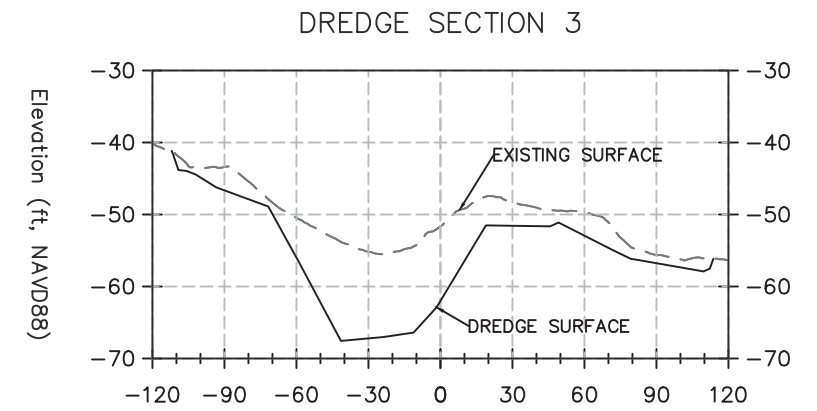
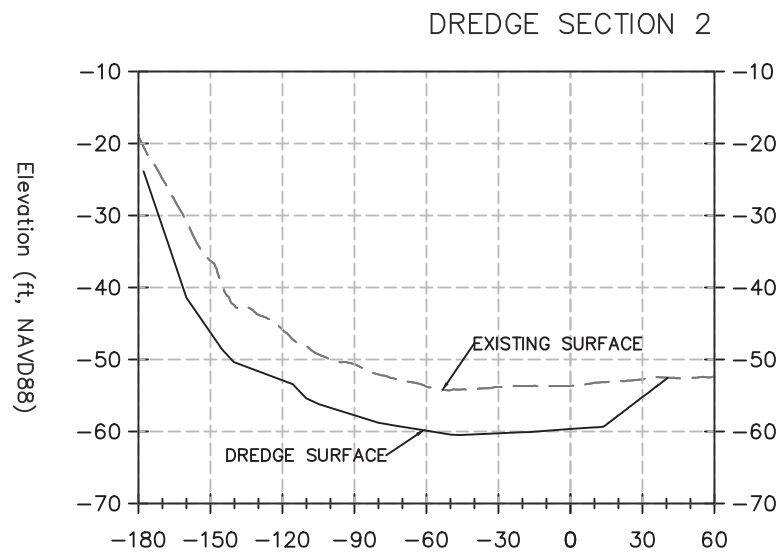
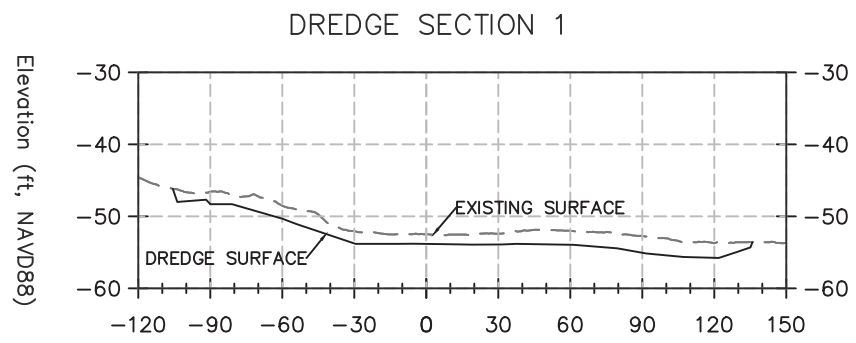

CENTRAL HUDSON GAS & ELECTRIC CORP.
FORMER NORTH WATER STREET MGP
POUGHKEEPSIE, NY

RIVER SEDIMENT DREDGE
CROSS SECTIONS











DATE: 2/1/2018

NYSDEC SITE ID: 60540671

REMEDIAL DESIGN/REMEDIAL ACTION WORK PLAN

FIGURE 3-12

LEGEND

-  RAILWAY TRACKS
-  GAS LINE
-  ELECTRIC LINE
-  FIBER OPTIC LINE
-  OVERHEAD ELECTRIC LINE
-  EDGE OF WALKWAY
-  SITE BOUNDARY
-  EXISTING FENCE
-  EDGE OF WOODS
-  BARRIER/BULKHEAD WALL
-  MONITORING WELL

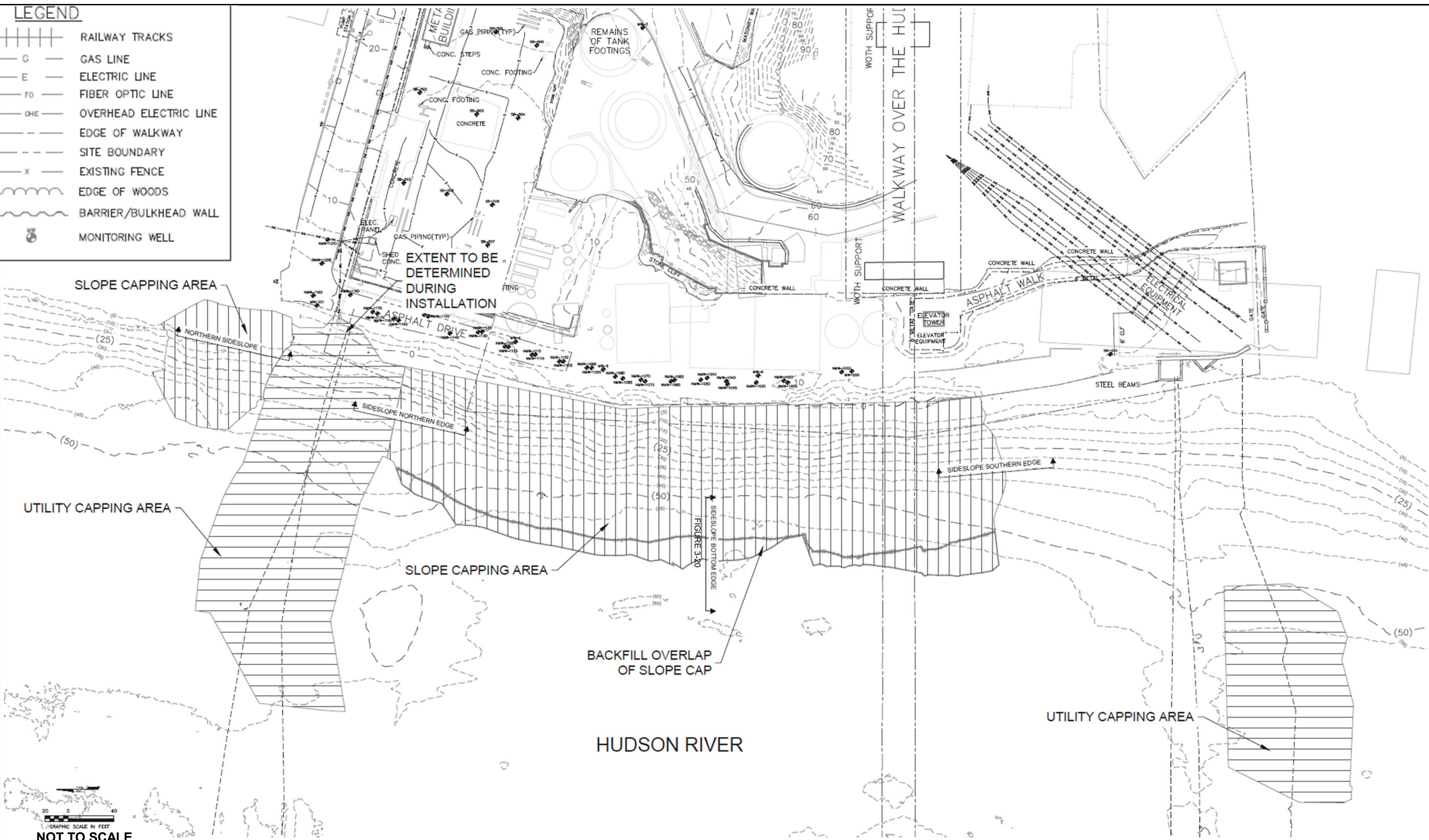

GRAPHIC SCALE IN FEET
 0 20 40
NOT TO SCALE



CENTRAL HUDSON GAS & ELECTRIC CORP.
 FORMER NORTH WATER STREET MGP
 POUGHKEEPSIE, NY

**RIVER SLOPE CAP
 AND UTILITY CAP LOCATION PLAN**

DATE: 8/1/2018

NYSDEC SITE ID: 60540671

REMEDIAL DESIGN/REMEDIAL ACTION WORK PLAN

FIGURE 3-13

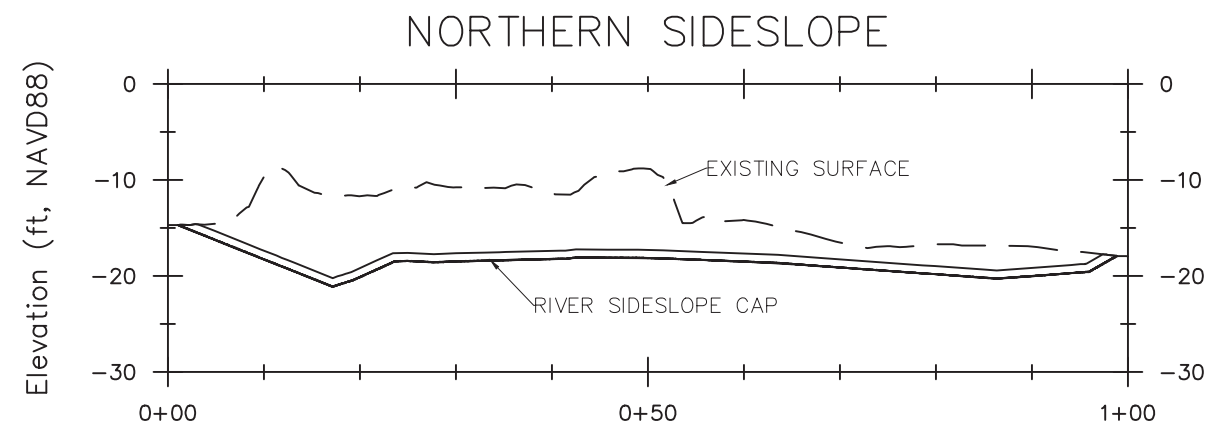
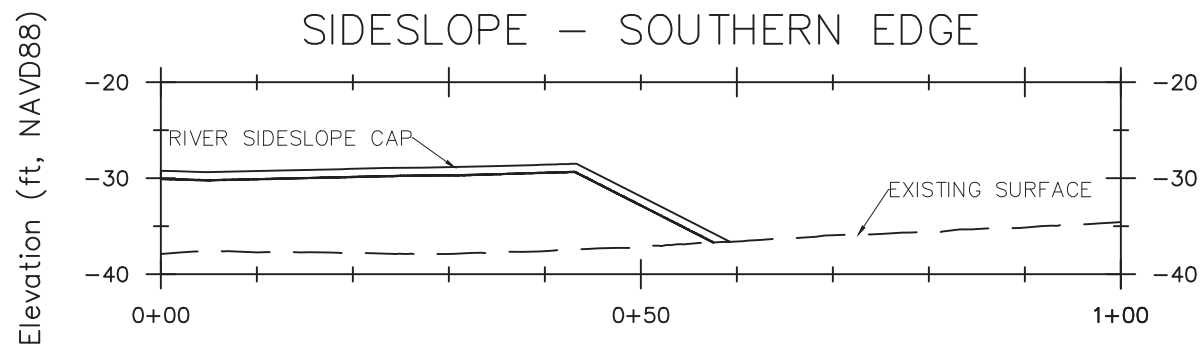
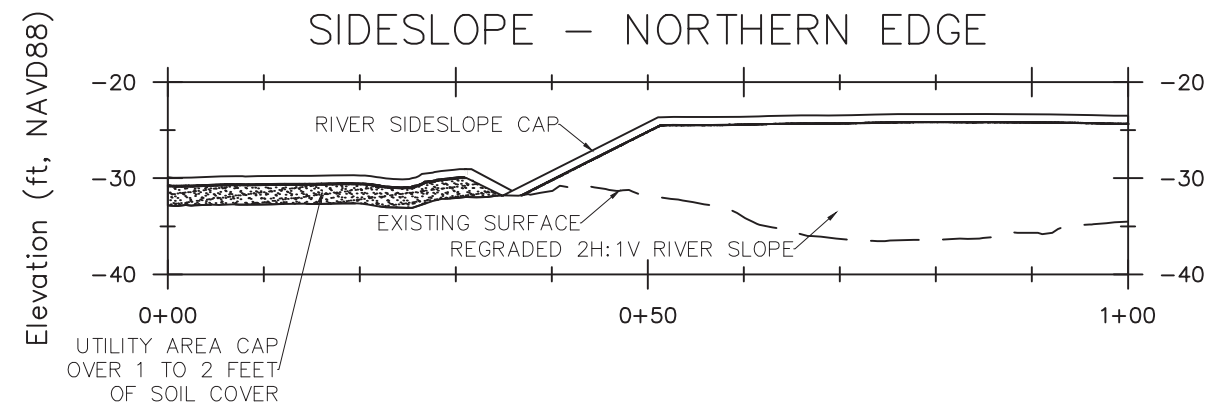

NOTES:

- CROSS SECTIONS SHOWN FOR CAP INSTALLATION ONLY. DOES NOT INCLUDE DETAILS OF RESTORED SURFACE INCLUDING RIP-RAP



CENTRAL HUDSON GAS & ELECTRIC CORP.
FORMER NORTH WATER STREET MGP
POUGHKEEPSIE, NY

UTILITY AND RIVER CAP CROSS SECTIONS

File: P:\Jobs\Rem_Eng\Project Files\CHGE\900 CAD\910 CAD\20 SHEETS\Conceptual Wall Design-1 FT WALL - snp.dwg Layout: 3-15 User: erica.hart Plotted: Feb 01, 2018 - 9:23am Xrefs:

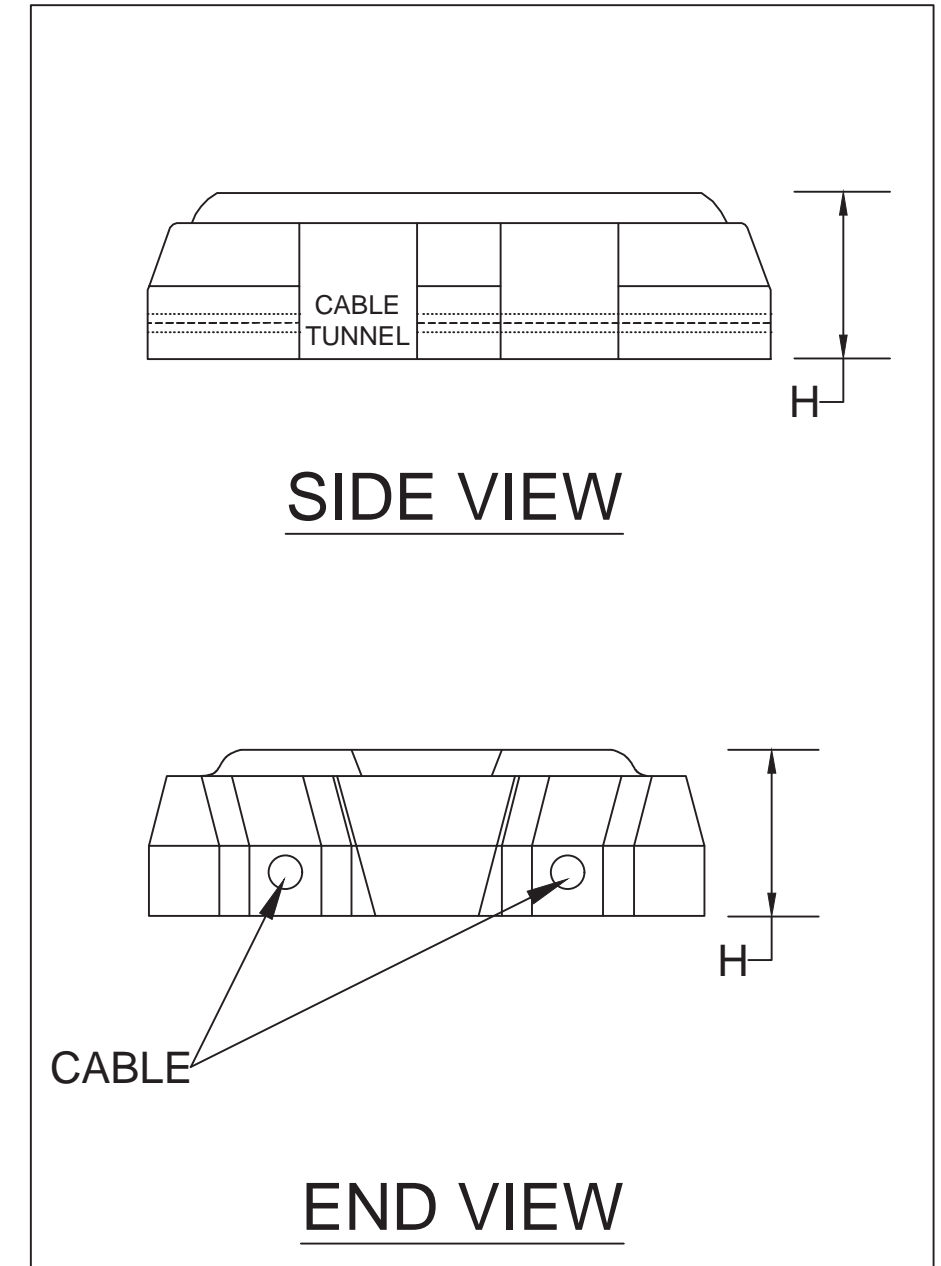
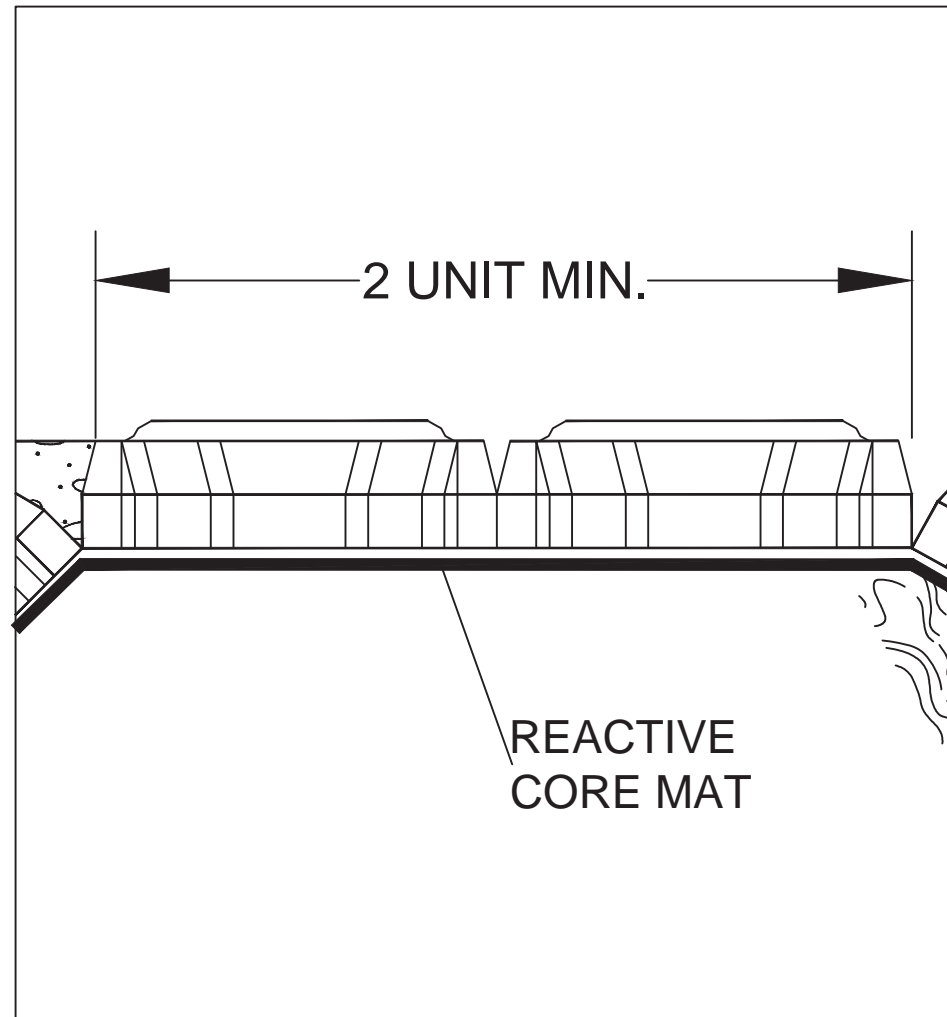
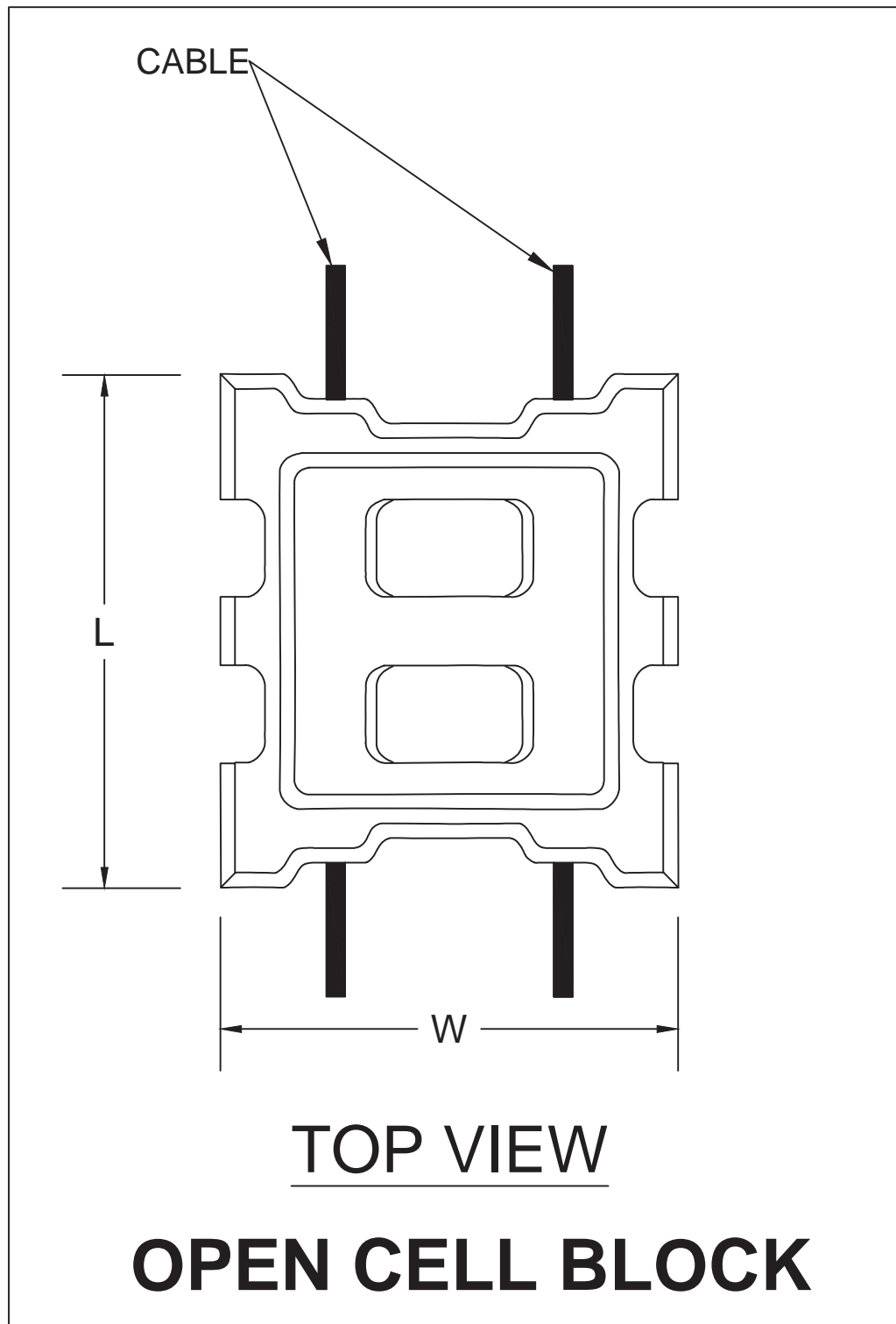

CENTRAL HUDSON GAS & ELECTRIC CORP.
FORMER NORTH WATER STREET MGP
POUGHKEEPSIE, NY

RIVER SLOPE AND UTILITY CAP DETAILS

DATE: 2/1/2018

NYSDEC SITE ID: 60540671

REMEDIAL DESIGN/REMEDIAL ACTION WORK PLAN

FIGURE 3-15

File: H:\Water Treatment CHGE.dwg Layout: 4-16 User: erica.hart Plotted: Feb 01, 2018 - 9:24am Xref's:

P1
SELF-PRIMING BARGE PUMP
NOM. 250 GPM
NOM. 60 FT TDH

P2
SELF-PRIMING DELIVERY PUMP
NOM. 250 GPM
NOM. 20 FT TDH

P3
TREATMENT SYSTEM PUMP
NOM. 250 GPM
NOM. 80 FT TDH

P4
DISCHARGE AND BACKWASH PUMP
NOM. 250 GPM
NOM. 40 FT TDH

P5
FLOCCULENT METERING PUMP
NOM. 2 GPM
WITH 100:1 TURN DOWN

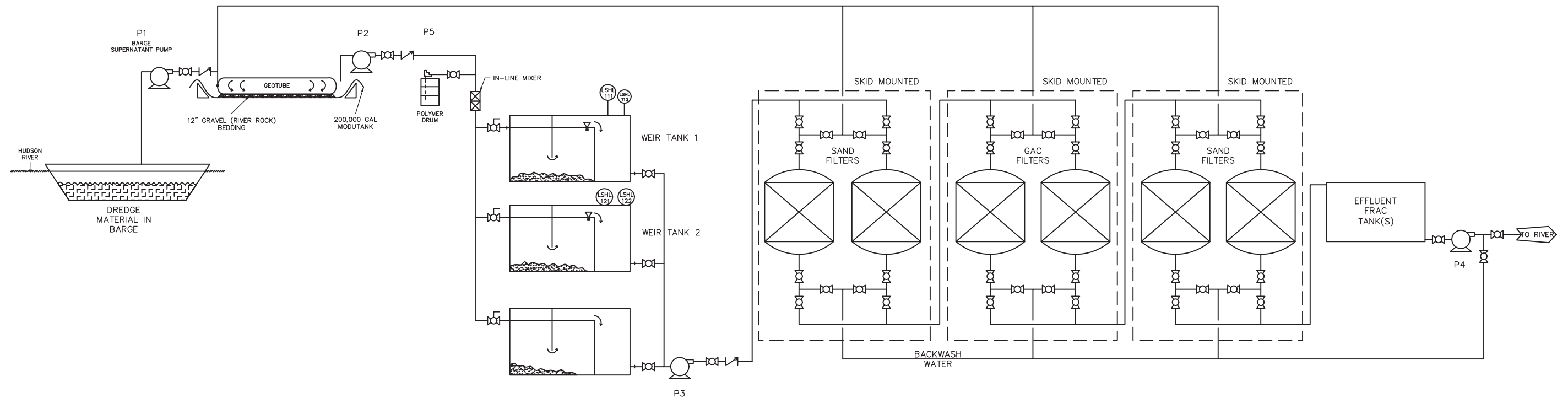

CENTRAL HUDSON GAS & ELECTRIC CORP.
FORMER NORTH WATER STREET MGP
POUGHKEEPSIE, NY

WATER TREATMENT PLANT PROCESS
FLOW DIAGRAM

DATE: 2/1/2018

NYSDEC SITE ID: 60540671

REMEDIAL DESIGN/REMEDIAL ACTION WORK PLAN

FIGURE 3-16

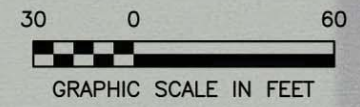
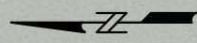

CENTRAL HUDSON GAS & ELECTRIC CORP. FORMER NORTH WATER STREET MGP POUGHKEEPSIE, NY		LANDSIDE RESTORATION PLAN	
DATE: 2/1/2018	NYSDEC SITE ID: 60540671	REMEDIAL DESIGN/REMEDIAL ACTION WORK PLAN	FIGURE 3-17

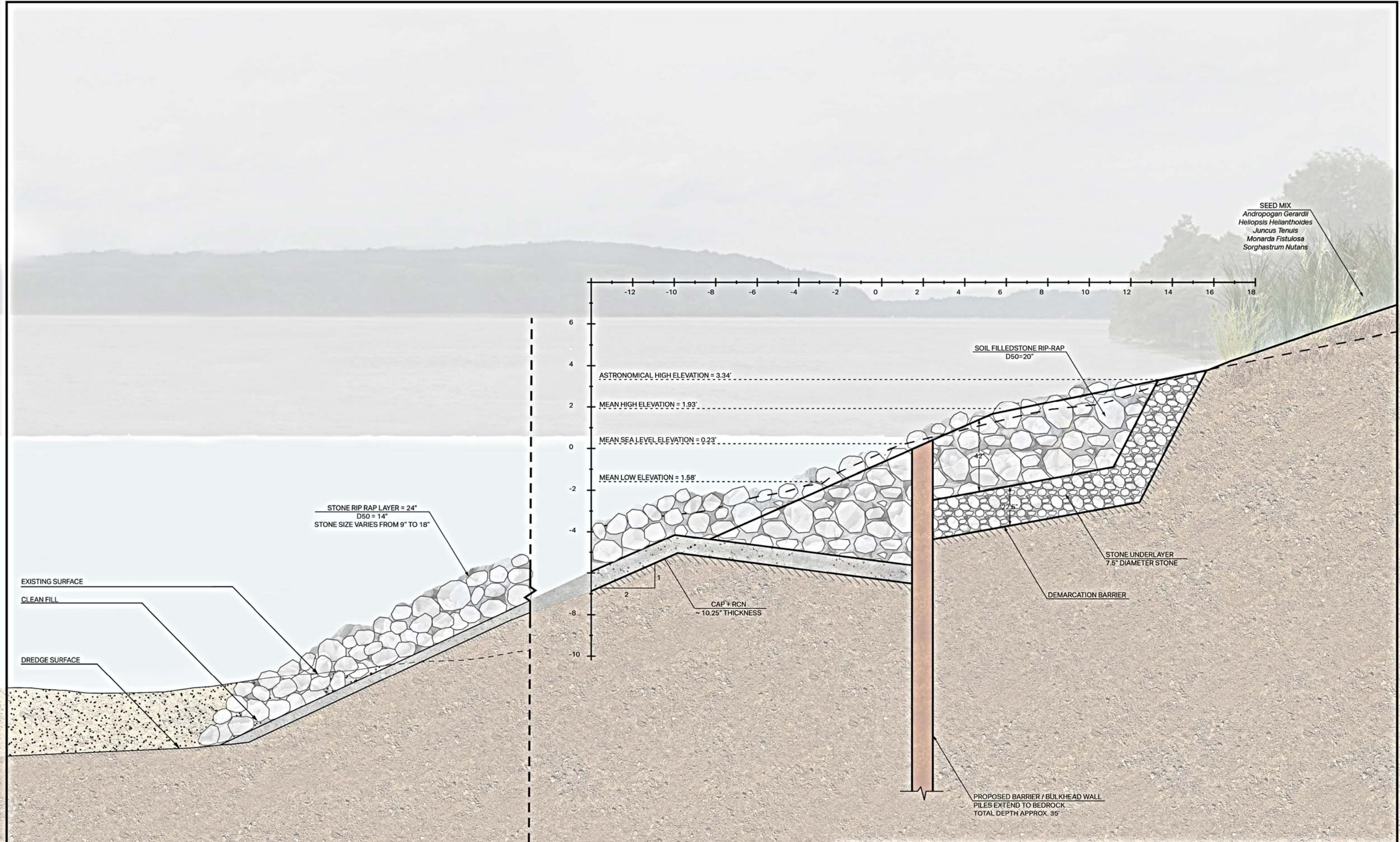

File: P:\Jobs\Rem_Eng\Project Files\CHGE\900 CAD\910 CAD\20 SHEETS\PDF\RDRA Work Plan.dwg Layout: 3-19 User: simventj Plotted: Aug 01, 2018 - 11:57am Xref's:

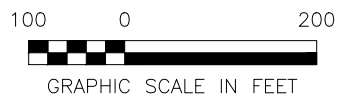
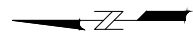
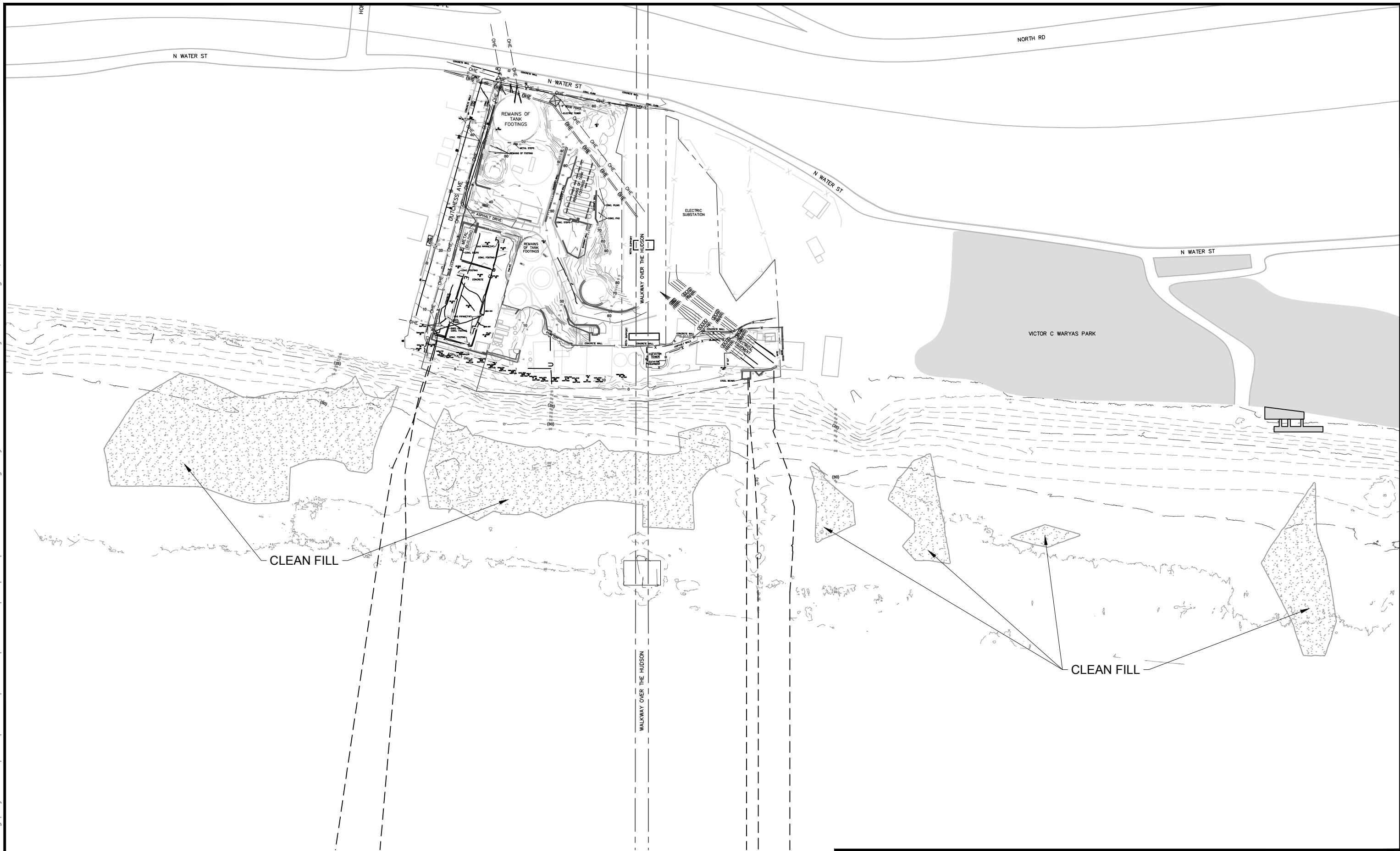

CENTRAL HUDSON GAS & ELECTRIC CORP.
FORMER NORTH WATER STREET MGP
POUGHKEEPSIE, NY

SEDIMENT DREDGE BACKFILL
AND RESTORATION PLAN

DATE: 8/01/2018

NYSDEC SITE ID: 60540671

REMEDIAL DESIGN/REMEDIAL ACTION WORK PLAN

FIGURE 3-19

File: P:\Jobs\Rem_Eng\Project Files\CHGE\900 CAD\910 CAD\20 SHEETS\Conceptual Wall Design - 8-01-18.dwg Layout: 3-20 User: sinventj Plotted: Aug 01, 2018 - 10:57am Xref's:

DREDGE AND SLOPE RESTORATION

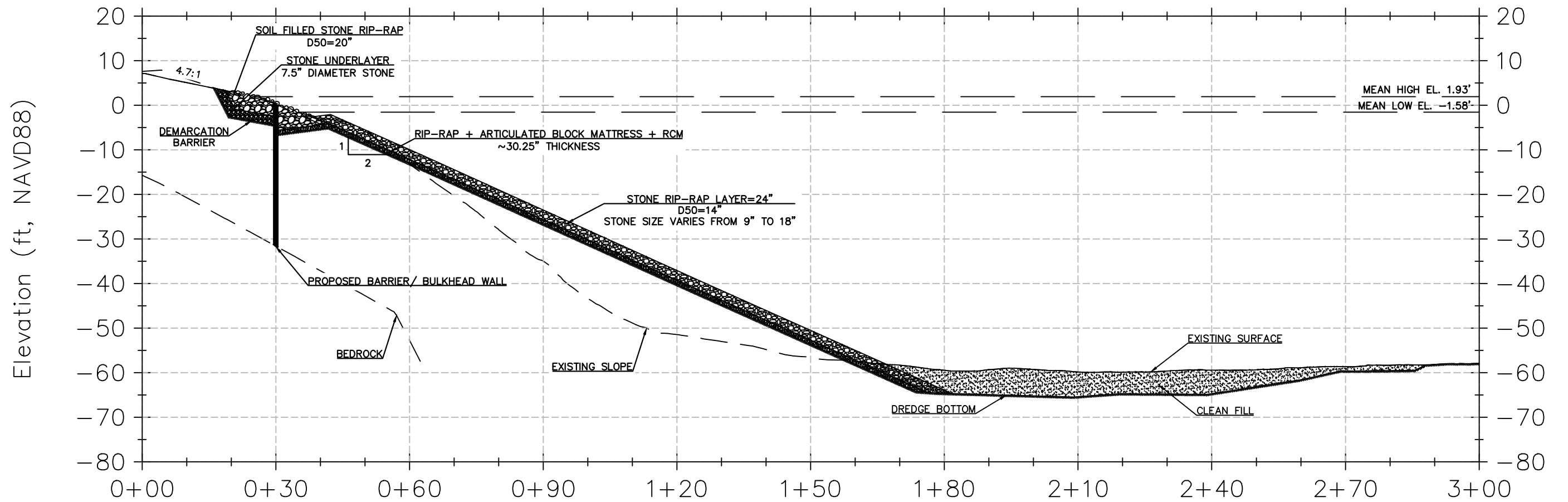

CENTRAL HUDSON GAS & ELECTRIC CORP.
FORMER NORTH WATER STREET MGP
POUGHKEEPSIE, NY

SEDIMENT DREDGE BACKFILL
AND RESTORATION PLAN

DATE: 8/01/2018

NYSDEC SITE ID: 60540671

REMEDIAL DESIGN/REMEDIAL ACTION WORK PLAN

FIGURE 3-20

Appendices

Appendix A

2016 New York State Department of Environmental Conservation Decision Document

DECISION DOCUMENT

CH - Water St. - Poughkeepsie MGP
Brownfield Cleanup Program
Poughkeepsie, Dutchess County
Site No. C314070
March 2016



Prepared by
Division of Environmental Remediation
New York State Department of Environmental Conservation

DECLARATION STATEMENT - DECISION DOCUMENT

CH - Water St. - Poughkeepsie MGP
Brownfield Cleanup Program
Poughkeepsie, Dutchess County
Site No. C314070
March 2016

Statement of Purpose and Basis

This document presents the remedy for the CH - Water St. - Poughkeepsie MGP site, a brownfield cleanup site. The remedial program was chosen in accordance with the New York State Environmental Conservation Law and Title 6 of the Official Compilation of Codes, Rules and Regulations of the State of New York (6 NYCRR) Part 375.

This decision is based on the Administrative Record of the New York State Department of Environmental Conservation (the Department) for the CH - Water St. - Poughkeepsie MGP site and the public's input to the proposed remedy presented by the Department.

Description of Selected Remedy

The elements of the selected remedy are as follows:

1. A remedial design program will be implemented to provide the details necessary for the construction, operation, optimization, maintenance, and monitoring of the remedial program. Green remediation principles and techniques will be implemented to the extent feasible in the design, implementation, and site management of the remedy as per DER-31. The major green remediation components are as follows;

- Considering the environmental impacts of treatment technologies and remedy stewardship over the long term;
- Reducing direct and indirect greenhouse gases and other emissions;
- Increasing energy efficiency and minimizing use of non-renewable energy;
- Conserving and efficiently managing resources and materials;
- Reducing waste, increasing recycling and increasing reuse of materials which would otherwise be considered a waste;
- Maximizing habitat value and creating habitat when possible;
- Fostering green and healthy communities and working landscapes which balance ecological, economic and social goals; and
- Integrating the remedy with the end use where possible and encouraging green and sustainable re-development.

2. Excavation and off-site disposal of upland contaminant source areas, located in the northern portion of the lower terrace area, to include:

- grossly contaminated soil, as defined in 6 NYCRR Part 375-1.2(u);
- removal of all underground MGP structures and underground piping; and
- soil containing visual coal tar or non-aqueous phase liquid;

3. Barrier Wall:

A subsurface barrier wall will be installed along the east bank of the Hudson River to prevent the migration of coal tar to the river. The wall will be constructed along the eastern bank of the river from the gas utility crossing immediately south of Dutchess Ave to a point approximately 450 feet to the south, where the walkway over the Hudson extends above the site. The wall will extend to a sufficient depth to prevent further movement of coal tar into the river. The final wall configuration, including the need for hydraulic relief and associated treatment, will be determined during the design phase of this project.

4. Coal Tar Recovery:

A series of coal tar recovery wells will be constructed behind the barrier wall to collect coal tar that accumulates behind the wall. The number, depth, type and spacing of the recovery wells will be determined during the design phase of the remedy. Coal tar will be collected periodically from each well; however, if wells are determined by the Department to accumulate large quantities of coal tar over extended time periods, they can be converted to automated collection.

5. In-situ Solidification:

In the area where the natural gas pipeline enters the upland portion of the site, which precludes the safe construction of the barrier wall, focused solidification (ISS) of soil horizons containing coal tar will be performed to prevent migration of coal tar toward the river

ISS is a process that binds the soil particles in place creating a low permeability mass. The contaminated soil will be mixed in place together with solidifying agents (typically Portland cement) or other binding agents using an excavator or augers. The soil and binding agents are mixed to produce a solidified mass resulting in a low permeability monolith. The solidified mass will then be covered with a cover system as described in element 8 to prevent direct exposure to the solidified mass. The resulting solid matrix will reduce or eliminate mobility of contamination and also reduce or eliminate the matrix as a source of groundwater contamination.

6. Hudson River Dredging and Capping:

Dredging of coal tar contaminated sediments from the Hudson River channel where feasible, as described below. Contaminated dredge material will be dewatered and shipped off-site for proper treatment and disposal. A suitable benthic habitat will be established on the river bottom following dredging.

In areas near and above utility crossings, where dredging of contaminated sediment cannot be performed due to the possibility of damaging the utilities, coal tar contaminated sediment will be

capped in place to prevent the migration of tar into the water column and to provide a clean habitat for benthic organisms.

Similarly, along the steep river bank immediately adjacent to the site, where dredging would create significant safety concerns due to the potential for slope instability, contaminated sediments will be capped in place to prevent tar migration into the water column, and to provide a clean benthic habitat. Because of the steep slopes involved in this area, it is anticipated that this cap will be installed as overlapping panels, which will be anchored in place to prevent downslope slumping of the cap. Similar panels were successfully tested during the site investigation.

7. Cover System:

A site cover will be required to allow for industrial use of the site, except as noted below. The cover will consist either of the structures such as buildings, pavement, sidewalks comprising the site development or a soil cover in areas where the upper one foot of exposed surface soil will exceed the applicable soil cleanup objectives (SCOs). Where the soil cover is required it will be a minimum of one foot of soil placed over a demarcation layer. In the lower terrace area outside of the fenced regulator and transformer stations, the soil cover will meet commercial SCOs to allow for passive recreational use such as a riverfront walkway. Removal of shallow soil prior to the placement of the cover may be required in some areas in order to maintain the appropriate finished grade. Soil cover material, including any fill material brought to the site, will meet the SCOs for cover material as set forth in 6 NYCRR Part 375-6.7(d).

Where the soil cover is required over the ISS treatment area, it will consist of a minimum of four feet of soil, in order to protect the underlying ISS mass from repeated freeze/thaw action. The uppermost foot of this soil cover must meet the SCOs for commercial use, due to the potential for this area along the riverfront to be included in future passive recreational facilities such as a riverfront walkway. For areas where solidified material underlies the cover, no demarcation layer is required. The solidified material itself will serve as the demarcation layer due to the obviously different nature of the material.

7. River and Riverbank Restoration:

The existing riverbank, made up largely of rip rap stone and a collapsing concrete crib wall, will be extensively disturbed during remediation. Existing gas and electric infrastructure along the riverbank must be protected as the site is remediated and restored. The remedial design will include a riverbank restoration plan which will incorporate measures to maximize wildlife habitat while protecting energy infrastructure and allowing for future development of a public access walkway along the river bank. Natural stream bank techniques will be employed to the extent practicable. All remedial and restoration work will comply with the substantive requirements of ECL Article 15 and 6 NYCRR Part 608.

8. Institutional Controls:

Imposition of institutional controls in the form of environmental easements for the controlled

properties that:

- require the remedial party or site owner to complete and submit to the Department a periodic certification of institutional and engineering controls in accordance with Part 375-1.8(h)(3);
- allow the use and development of the controlled property for industrial use, except for areas where public access will be provided, which will be commercial use, as defined by Part 375-1.8(g), although land use is subject to local zoning laws;
- restrict the use of groundwater as a source of potable or process water, without necessary water quality treatment as determined by the NYSDOH or Dutchess County DOH; and
- require compliance with the Department approved Site Management Plan.

9. Site Management Plan

A Site Management Plan is required, which includes the following:

1. an Institutional and Engineering Control Plan that identifies all use restrictions and engineering controls for the site and details the steps and media-specific requirements necessary to ensure the following institutional and/or engineering controls remain in place and effective:

Institutional Controls:

The Environmental Easement discussed in Paragraph 8 above.

Engineering Controls:

- The cover system discussed in Paragraph 7 above;
- The solidified soils discussed in Paragraph 5 above;
- The sediment cap discussed in Paragraph 6 above; and
- The coal tar recovery system discussed in Paragraph 4 above.

This plan includes, but may not be limited to:

- o an Excavation Plan which details the provisions for management of future excavations in areas of remaining contamination;
- o descriptions of the provisions of the environmental easement including any land use, and groundwater use restrictions;
- o a provision for evaluation of the potential for soil vapor intrusion if the current building becomes occupied or if new buildings are developed on the site in the future, including provision for implementing actions recommended to address exposures related to soil vapor intrusion;
- o provisions for the management and inspection of the identified engineering controls;
- o maintaining site access controls and Department notification; and
- o the steps necessary for the periodic reviews and certification of the institutional and/or engineering controls.

2. a Monitoring Plan to assess the performance and effectiveness of the remedy. The plan includes, but may not be limited to:

- o monitoring of groundwater to assess the performance and effectiveness of the remedy;
- o a schedule of monitoring and frequency of submittals to the Department;

o monitoring for vapor intrusion for any occupied existing or future buildings developed on the site, as may be required by the Institutional and Engineering Control Plan discussed above.

3. an Operation and Maintenance (O&M) Plan to ensure continued operation, maintenance, optimization, monitoring, inspection, and reporting of any mechanical or physical components of the remedy. The plan includes, but is not limited to:

- o procedures for operating and maintaining the remedy;
- o compliance monitoring of treatment systems to ensure proper O&M as well as providing the data for any necessary permit or permit equivalent reporting;
- o maintaining site access controls and Department notification; and
- o providing the Department access to the site and O&M records.

Declaration

The remedy conforms with promulgated standards and criteria that are directly applicable, or that are relevant and appropriate and takes into consideration Department guidance, as appropriate. The remedy is protective of public health and the environment.

March 30, 2016
Date

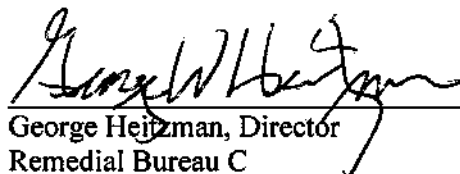
George Heitzman, Director
Remedial Bureau C

DECISION DOCUMENT

CH - Water St. - Poughkeepsie MGP
Poughkeepsie, Dutchess County
Site No. C314070
March 2016

SECTION 1: SUMMARY AND PURPOSE

The New York State Department of Environmental Conservation (the Department), in consultation with the New York State Department of Health (NYSDOH), has selected a remedy for the above referenced site. The disposal of contaminants at the site has resulted in threats to public health and the environment that would be addressed by the remedy. The disposal or release of contaminants at this site, as more fully described in this document, has contaminated various environmental media. Contaminants include hazardous waste and/or petroleum.

The New York State Brownfield Cleanup Program (BCP) is a voluntary program. The goal of the BCP is to enhance private-sector cleanups of brownfields and to reduce development pressure on "greenfields." A brownfield site is real property, the redevelopment or reuse of which may be complicated by the presence or potential presence of a contaminant.

The Department has issued this document in accordance with the requirements of New York State Environmental Conservation Law and 6 NYCRR Part 375. This document is a summary of the information that can be found in the site-related reports and documents.

SECTION 2: CITIZEN PARTICIPATION

The Department seeks input from the community on all remedies. A public comment period was held, during which the public was encouraged to submit comment on the proposed remedy. All comments on the remedy received during the comment period were considered by the Department in selecting a remedy for the site. Site-related reports and documents were made available for review by the public at the following document repository:

Adriance Memorial Library
93 Market Street
Poughkeepsie, NY 12601
Phone: (845) - 485 – 3445

Receive Site Citizen Participation Information By Email

Please note that the Department's Division of Environmental Remediation (DER) is "going paperless" relative to citizen participation information. The ultimate goal is to distribute citizen participation information about contaminated sites electronically by way of county email

listservs. Information will be distributed for all sites that are being investigated and cleaned up in a particular county under the State Superfund Program, Environmental Restoration Program, Brownfield Cleanup Program, Voluntary Cleanup Program, and Resource Conservation and Recovery Act Program. We encourage the public to sign up for one or more county listservs at <http://www.dec.ny.gov/chemical/61092.html>

SECTION 3: SITE DESCRIPTION AND HISTORY

Location:

The site is located on the eastern bank of the Hudson River at the end of Dutchess Avenue, in the north end of the City of Poughkeepsie. The site is approximately 13 acres in size and is bounded by: the Hudson River to the west, Dutchess Avenue to the north, North Water Street to the east and the Fallkill Creek to the south. An abandoned lumber treatment facility (AC Dutton Lumber), remediated under a Brownfield Cleanup Agreement and currently under redevelopment, forms the remainder of the northern site boundary. To the east, beyond Water Street, lies a Metro North railroad yard.

Site Features:

The upland portion of the site consists of two relatively flat terraces, separated by steep, rocky slopes with very thin soil cover. The lower terrace lies on the banks of the Hudson River, roughly 5-10 feet above sea level. The upper terrace is roughly 50 feet higher, bordering Water Street. The only structure located at the site is an unoccupied cinder block valve house associated with the gas regulator station.

Important energy infrastructure is located on the site. Gas and electric lines cross beneath the Hudson River at this location, and connect with gas and electrical lines which serve much wider areas surrounding Poughkeepsie. An electrical transformer station is located on the lower terrace at the southwestern portion of the site, where the electrical transmission line meets the shoreline and a natural gas regulator station occupies the northwestern corner of the lower terrace of the site where the gas transmission line meets the shoreline. The transformer station and regulator station are each enclosed within a fence.

Current Zoning and Land Use:

The site is zoned for industrial use. Surrounding land uses are predominantly, but not exclusively, industrial. Immediately north and south of the site, riverfront access provides for recreational use of the waterfront. Immediately across Dutchess Avenue to the north of the site, a large scale restricted residential redevelopment is underway. Two residences are situated directly across Dutchess Avenue at the northeast corner of the site.

The City of Poughkeepsie has supported efforts to construct a continuous pedestrian walkway along the river bank, and to connect this walkway with the Walkway Over the Hudson, which occupies a former railroad bridge that spans the site and the Hudson River. It is anticipated that the riverfront walkway may be extended to include riverfront portions of this MGP site at some point in the future.

Past Uses of the Site:

The site housed a large manufactured gas plant (MGP) from 1911 to the mid-1950s. Coal tar from the gas manufacturing process leaked from storage vessels and piping, and is still present in the subsurface. Some of these tars still discharge sporadically into the Hudson River.

Previous investigations at the site include: Phase 1 Investigation (1986), Phase 2 Investigation (1990), Supplemental RCRA Testing (1991), Supplemental Preliminary Site Assessment (2000), Supplemental Land Investigation (2003), Supplemental Land and River Investigations (2004), Supplemental River and Land Investigations (2005).

Site Geology and Hydrogeology:

The upper tier of the site consists of highly deformed slate and limestone bedrock, with a very thin fill cover. The lower tier consists of fill containing broken rock derived from the blasting of the cliff face and silty sand. Bedrock on the lower tier ranges from 0 to 15' below grade, deepening toward the river.

Groundwater levels on the upper tier range from 10 to 19 feet below ground surface (bgs) and from 0 to 14 feet bgs on the lower tier. Flow in both the overburden and bedrock aquifers is to the west, toward the river. The Hudson River in this area is a tidal stream and tidal influences to near shore groundwater levels on the lower tier is pronounced.

A site location map is attached as Figure 1.

SECTION 4: LAND USE AND PHYSICAL SETTING

The Department may consider the current, intended, and reasonably anticipated future land use of the site and its surroundings when evaluating a remedy for soil remediation. For this site, alternatives (or an alternative) that restrict(s) the use of the site to industrial use as described in Part 375-1.8(g) were/was evaluated in addition to an alternative which would allow for unrestricted use of the site.

A comparison of the results of the Remedial Investigation (RI) to the appropriate standards, criteria and guidance values (SCGs) for the identified land use and the unrestricted use SCGs for the site contaminants is available in the RI Report.

SECTION 5: ENFORCEMENT STATUS

The Applicant under the Brownfield Cleanup Agreement is a Participant. The Applicant has an obligation to address on-site and off-site contamination. Accordingly, no enforcement actions are necessary.

SECTION 6: SITE CONTAMINATION

6.1: Summary of the Remedial Investigation

A remedial investigation (RI) serves as the mechanism for collecting data to:

- characterize site conditions;
- determine the nature of the contamination; and
- assess risk to human health and the environment.

The RI is intended to identify the nature (or type) of contamination which may be present at a site and the extent of that contamination in the environment on the site, or leaving the site. The RI reports on data gathered to determine if the soil, groundwater, soil vapor, indoor air, surface water or sediments may have been contaminated. Monitoring wells are installed to assess groundwater and soil borings or test pits are installed to sample soil and/or waste(s) identified. If other natural resources are present, such as surface water bodies or wetlands, the water and sediment may be sampled as well. Based on the presence of contaminants in soil and groundwater, soil vapor will also be sampled for the presence of contamination. Data collected in the RI influence the development of remedial alternatives. The RI report is available for review in the site document repository and the results are summarized in section 6.3.

The analytical data collected on this site includes data for:

- groundwater
- surface water
- soil
- sediment
- soil vapor

6.1.1: Standards, Criteria, and Guidance (SCGs)

The remedy must conform to promulgated standards and criteria that are directly applicable or that are relevant and appropriate. The selection of a remedy must also take into consideration guidance, as appropriate. Standards, Criteria and Guidance are hereafter called SCGs.

To determine whether the contaminants identified in various media are present at levels of concern, the data from the RI were compared to media-specific SCGs. The Department has developed SCGs for groundwater, surface water, sediments, and soil. The NYSDOH has developed SCGs for drinking water and soil vapor intrusion. For a full listing of all SCGs see: <http://www.dec.ny.gov/regulations/61794.html>

6.1.2: RI Results

The data have identified contaminants of concern. A "contaminant of concern" is a contaminant that is sufficiently present in frequency and concentration in the environment to require evaluation for remedial action. Not all contaminants identified on the property are contaminants of concern. The nature and extent of contamination and environmental media requiring action are summarized below. Additionally, the RI Report contains a full discussion of the data. The contaminant(s) of concern identified at this site is/are:

coal tar

benzene, toluene, ethylbenzene and
xylenes (BTEX)

polycyclic aromatic hydrocarbons (PAHS),
total

The contaminant(s) of concern exceed the applicable SCGs for:

- groundwater
- soil
- sediment

6.2: Interim Remedial Measures

An interim remedial measure (IRM) is conducted at a site when a source of contamination or exposure pathway can be effectively addressed before issuance of the Decision Document.

The following IRM(s) has/have been completed at this site based on conditions observed during the RI.

Shallow soil removal for construction of elevator to the Walkway Over the Hudson

A soil removal IRM was conducted in 2012 by Central Hudson Gas and Electric, to allow for construction of an elevator to the Walkway Over the Hudson (WOTH) New York State Park and a pedestrian walkway to reach the elevator.

The IRM for the elevator to the WOTH included the removal and off-site disposal of the uppermost 2 feet of soil located on the southern portion of the site adjacent to a proposed new walking pathway and elevator. Clean soil meeting restricted residential SCOs was then placed above a demarcation layer as backfill in the excavated area. The walking pathway and elevator associated with the WOTH, were constructed by others and were not part of the IRM. They are separated from the rest of the site by a fence.

6.3: Summary of Environmental Assessment

This section summarizes the assessment of existing and potential future environmental impacts presented by the site. Environmental impacts may include existing and potential future exposure pathways to fish and wildlife receptors, wetlands, groundwater resources, and surface water. The RI report presents a detailed discussion of any existing and potential impacts from the site to fish and wildlife receptors.

Contaminants of Concern:

The principal waste disposed on the site was MGP tar, which is a brown, oily liquid that is slightly denser than water. Large amounts of this tar escaped into the subsurface from plant structures located on the lower terrace near the river bank. This tar can still be found in soils and bedrock beneath the site. Tar was also discharged directly to the Hudson River, where it is found in sediments on the river bottom.

The tar contains high levels of benzene, toluene, ethylbenzene and xylenes, collectively known as BTEX, and polycyclic aromatic hydrocarbon (PAH) compounds. Both groups of compounds have been found in site groundwater.

Impacted Media:

The soil and bedrock aquifers beneath the western portion of the site, along the banks of the Hudson River, are contaminated with separate phase MGP tar and with dissolved BTEX and PAH compounds derived from the tar. MGP tar is being collected on a bi-annual basis from two wells along the western boundary of the site. Over 500 gallons have been collected from one overburden well along the riverfront. Hudson River sediments contain MGP tar and PAH contamination derived from the tar.

Subsurface Soil and Bedrock:

On the upper tier of the site, tar was observed in bedrock fractures in 3 of 32 soil borings. On the lower tier of the site, tar was observed in subsurface soil in 54 of 68 sample locations. BTEX was detected in 15 of the 20 samples analyzed. PAH constituents were detected in 19 of 20 samples. Total BTEX concentrations ranged from 0.001 to 916 parts per million (ppm) and total PAH concentrations ranged from 0.17 ppm to 16,300 ppm. Twelve of the 20 samples analyzed contained concentrations of the following individual constituents above the industrial use SCOs: benzene, benzo(a)anthracene, benzo(a)pyrene, benzo(b)fluoranthene, benzo(k)fluoranthene, chrysene, naphthalene, phenanthrene, and pyrene.

Six subsurface soil samples were collected and analyzed for target analyte list (TAL) metals. One or more metals were detected at each location. Arsenic was detected at concentrations exceeding industrial use SCOs at one location that is co-located with visible non-aqueous phase liquid (NAPL) and industrial use SCO exceedances for PAHs.

Surface Soil:

Twenty-two surface soil samples were collected and analyzed for BTEX and PAHs. BTEX constituents were detected in 7 of the 22 samples with total BTEX concentrations ranging from 0.00061 ppm to 151 ppm. No samples exhibited concentrations of individual BTEX constituents above industrial use SCOs. PAH constituents were detected in 21 of the 22 samples, with detected total PAH concentrations ranging from 0.55 ppm to 5,200 ppm. Thirteen of the twenty-two samples exhibited concentrations of one or more of the following individual PAH constituents exceeding industrial use SCOs: benzo(a)anthracene, benzo(a)pyrene, benzo(b)fluoranthene, dibenzo(a,h)anthracene, indeno(1,2,3,c-d)pyrene, naphthalene.

Twenty surface soil samples were analyzed for TAL metals. Measurable concentrations of metals were detected in 14 of the 20 samples. None of the concentrations exceeded industrial use SCOs.

Groundwater:

In three overburden wells sampled, BTEX concentrations ranged from non-detect to 9,744 parts per billion (ppb) and total PAH concentrations ranged from non-detect to 691 ppb. Trace thicknesses of NAPL were observed in all three overburden wells. In four bedrock wells sampled, total BTEX concentrations ranged from non-detect to 138 ppb and total PAH

concentrations ranged from non-detect to 462 ppb. In three bedrock wells sampled for TAL metals, cadmium was detected at concentrations ranging from 5 to 8 ppb and cyanide was detected at concentrations ranging from 80 to 460 ppb. Trace thicknesses of NAPL were observed in three of the four bedrock wells sampled.

Groundwater samples exceeded Ambient Water Quality Standards for the following individual constituents: benzene, ethylbenzene, m/p-Xylene, o-Xylene and toluene; acenaphthene, benzo(a)anthracene, benzo(a)pyrene, benzo(b)fluoranthene, benzo(k)fluoranthene, chrysene, fluorene, indeno(1,2,3-cd)pyrene, naphthalene, phenanthrene, pyrene, cadmium and cyanide.

Sediment:

Tar impacted sediments extend approximately 300 feet from the shoreline, and from approximately 350 feet north of the gas transmission line to approximately 350 feet south of the electrical transmission line. BTEX was observed in each of the nine sediment samples analyzed for volatile organic compounds (VOCs), with total BTEX concentrations ranging from 0.0091 ppm to 1,310 ppm. PAHs were detected in 239 of 249 samples analyzed for semi-volatile organic compounds (SVOCs), with concentrations ranging from non-detect to 21,200 ppm. 207 of the 239 samples collected for SVOC analysis exceeded the Class A sediment screening value of 4 ppm total PAH.

Surface Water:

Three surface water samples were collected from the Hudson River for analysis. Although none of the analytical results exceeded ambient water quality standards, the gas ebullition within tar-impacted river sediments routinely results in sheens and slicks on the river surface near the site.

Soil Vapor:

Two of the twenty four soil vapor samples collected on the site exhibited detectable levels of benzene ranging from 32 ug/m³ to 64 ug/m³ respectively .

Special Resources impacted.

The Hudson River is impacted by coal tar in the area near the MGP site, with both sediments and the overlying water column affected. Tar continues to move into the Hudson River by subsurface migration from upland source areas, but the principal impact of tar to the water column is the result of releases of tar from the tar contaminated on the river bottom which causes frequent slicks and sheens on the water surface, primarily during the warm weather months.

The site is within the Kingston-Poughkeepsie Deepwater Significant Coastal Fish and Wildlife Habitat area, a stretch of the Hudson River that is ecologically important to the life history of two endangered species, the Atlantic and Shortnose Sturgeon

6.4: Summary of Human Exposure Pathways

This human exposure assessment identifies ways in which people may be exposed to site-related contaminants. Chemicals can enter the body through three major pathways (breathing, touching or swallowing). This is referred to as *exposure*.

Access to the site is restricted and measures are in place to control the potential for coming in contact with subsurface soil and groundwater contamination remaining on the site. Contaminated groundwater at the site is not used for drinking or other purposes, and the site is served by a public water supply that obtains water from a different source not affected by this contamination. Volatile organic compounds in the soil or groundwater may move into the soil vapor (air spaces within the soil), which in turn may move into overlying buildings and affect the indoor air quality. This process, which is similar to movement of radon gas from the subsurface into the indoor air of buildings, is referred to as soil vapor intrusion. Because there are no occupied buildings on the site, the inhalation of site-related contaminants due to soil vapor intrusion does not represent a current concern. People using the Hudson River for recreational purposes such as boating may come into contact with site-related contaminants associated with sheens present on the water's surface.

6.5: Summary of the Remediation Objectives

The objectives for the remedial program have been established through the remedy selection process stated in 6 NYCRR Part 375. The goal for the remedial program is to restore the site to pre-disposal conditions to the extent feasible. At a minimum, the remedy shall eliminate or mitigate all significant threats to public health and the environment presented by the contamination identified at the site through the proper application of scientific and engineering principles.

The remedial action objectives for this site are:

Groundwater

RAOs for Public Health Protection

- Prevent ingestion of groundwater with contaminant levels exceeding drinking water standards.
- Prevent contact with, or inhalation of volatiles, from contaminated groundwater.

RAOs for Environmental Protection

- Restore ground water aquifer to pre-disposal/pre-release conditions, to the extent practicable.
- Prevent the discharge of contaminants to surface water.
- Remove the source of ground or surface water contamination.

Soil

RAOs for Public Health Protection

- Prevent ingestion/direct contact with contaminated soil.

RAOs for Environmental Protection

- Prevent migration of contaminants that would result in groundwater or surface water contamination.
- Prevent impacts to biota from ingestion/direct contact with soil causing toxicity or impacts from bioaccumulation through the terrestrial food chain.

Surface Water

RAOs for Public Health Protection

- Prevent contact or inhalation of contaminants from impacted water bodies.
- Prevent surface water contamination which may result in fish advisories.

RAOs for Environmental Protection

- Prevent impacts to biota from ingestion/direct contact with surface water causing toxicity and impacts from bioaccumulation through the marine or aquatic food chain.

Sediment

RAOs for Public Health Protection

- Prevent direct contact with contaminated sediments.
- Prevent surface water contamination which may result in fish advisories.

RAOs for Environmental Protection

- Prevent releases of contaminant(s) from sediments that would result in surface water levels in excess of (ambient water quality criteria).
- Prevent impacts to biota from ingestion/direct contact with sediments causing toxicity or impacts from bioaccumulation through the marine or aquatic food chain.
- Restore sediments to pre-release/background conditions to the extent feasible.

Soil Vapor

RAOs for Public Health Protection

- Mitigate impacts to public health resulting from existing, or the potential for, soil vapor intrusion into buildings at a site.

SECTION 7: ELEMENTS OF THE SELECTED REMEDY

The alternatives developed for the site and the evaluation of the remedial criteria are presented in the Alternative Analysis. The remedy is selected pursuant to the remedy selection criteria set forth in DER-10, Technical Guidance for Site Investigation and Remediation and 6 NYCRR Part 375.

The selected remedy is a Track 2: Restricted use with generic soil cleanup objectives remedy.

The selected remedy is referred to as the Source Excavation, Barrier Wall with Tar Collection, and Sediment Removal with L remedy.

The elements of the selected remedy, as shown in Figure 2, are as follows:

1. A remedial design program will be implemented to provide the details necessary for the construction, operation, optimization, maintenance, and monitoring of the remedial program. Green remediation principles and techniques will be implemented to the extent feasible in the design, implementation, and site management of the remedy as per DER-31. The major green remediation components are as follows;

- Considering the environmental impacts of treatment technologies and remedy stewardship over the long term;
- Reducing direct and indirect greenhouse gases and other emissions;

- Increasing energy efficiency and minimizing use of non-renewable energy;
- Conserving and efficiently managing resources and materials;
- Reducing waste, increasing recycling and increasing reuse of materials which would otherwise be considered a waste;
- Maximizing habitat value and creating habitat when possible;
- Fostering green and healthy communities and working landscapes which balance ecological, economic and social goals; and
- Integrating the remedy with the end use where possible and encouraging green and sustainable re-development.

2. Excavation and off-site disposal of upland contaminant source areas, located in the northern portion of the lower terrace area, to include:

- grossly contaminated soil, as defined in 6 NYCRR Part 375-1.2(u);
- removal of all underground MGP structures and underground piping; and
- soil containing visual coal tar or non-aqueous phase liquid;

3. Barrier Wall:

A subsurface barrier wall will be installed along the east bank of the Hudson River to prevent the migration of coal tar to the river. The wall will be constructed along the eastern bank of the river from the gas utility crossing immediately south of Dutchess Ave to a point approximately 450 feet to the south, where the walkway over the Hudson extends above the site. The wall will extend to a sufficient depth to prevent further movement of coal tar into the river. The final wall configuration, including the need for hydraulic relief and associated treatment, will be determined during the design phase of this project.

4. Coal Tar Recovery:

A series of coal tar recovery wells will be constructed behind the barrier wall to collect coal tar that accumulates behind the wall. The number, depth, type and spacing of the recovery wells will be determined during the design phase of the remedy. Coal tar will be collected periodically from each well; however, if wells are determined by the Department to accumulate large quantities of coal tar over extended time periods, they can be converted to automated collection.

5. In-situ Solidification:

In the area where the natural gas pipeline enters the upland portion of the site, which precludes the safe construction of the barrier wall, focused solidification (ISS) of soil horizons containing coal tar will be performed to prevent migration of coal tar toward the river

ISS is a process that binds the soil particles in place creating a low permeability mass. The contaminated soil will be mixed in place together with solidifying agents (typically Portland cement) or other binding agents using an excavator or augers. The soil and binding agents are mixed to produce a solidified mass resulting in a low permeability monolith. The solidified mass

will then be covered with a cover system as described in element 8 to prevent direct exposure to the solidified mass. The resulting solid matrix will reduce or eliminate mobility of contamination and also reduce or eliminate the matrix as a source of groundwater contamination.

6. Hudson River Dredging and Capping:

Dredging of coal tar contaminated sediments from the Hudson River channel where feasible, as described below. Contaminated dredge material will be dewatered and shipped off-site for proper treatment and disposal. A suitable benthic habitat will be established on the river bottom following dredging.

In areas near and above utility crossings, where dredging of contaminated sediment cannot be performed due to the possibility of damaging the utilities, coal tar contaminated sediment will be capped in place to prevent the migration of tar into the water column and to provide a clean habitat for benthic organisms.

Similarly, along the steep river bank immediately adjacent to the site, where dredging would create significant safety concerns due to the potential for slope instability, contaminated sediments will be capped in place to prevent tar migration into the water column, and to provide a clean benthic habitat. Because of the steep slopes involved in this area, it is anticipated that this cap will be installed as overlapping panels, which will be anchored in place to prevent downslope slumping of the cap. Similar panels were successfully tested during the site investigation.

7. Cover System:

A site cover will be required to allow for industrial use of the site, except as noted below. The cover will consist either of the structures such as buildings, pavement, sidewalks comprising the site development or a soil cover in areas where the upper one foot of exposed surface soil will exceed the applicable soil cleanup objectives (SCOs). Where the soil cover is required it will be a minimum of one foot of soil placed over a demarcation layer. In the lower terrace area outside of the fenced regulator and transformer stations, the soil cover will meet commercial SCOs to allow for passive recreational use such as a riverfront walkway. Removal of shallow soil prior to the placement of the cover may be required in some areas in order to maintain the appropriate finished grade. Soil cover material, including any fill material brought to the site, will meet the SCOs for cover material as set forth in 6 NYCRR Part 375-6.7(d).

Where the soil cover is required over the ISS treatment area, it will consist of a minimum of four feet of soil, in order to protect the underlying ISS mass from repeated freeze/thaw action. The uppermost foot of this soil cover must meet the SCOs for commercial use, due to the potential for this area along the riverfront to be included in future passive recreational facilities such as a riverfront walkway. For areas where solidified material underlies the cover, no demarcation layer is required. The solidified material itself will serve as the demarcation layer due to the obviously different nature of the material.

7. River and Riverbank Restoration:

The existing riverbank, made up largely of rip rap stone and a collapsing concrete crib wall, will be extensively disturbed during remediation. Existing gas and electric infrastructure along the riverbank must be protected as the site is remediated and restored. The remedial design will include a riverbank restoration plan which will incorporate measures to maximize wildlife habitat while protecting energy infrastructure and allowing for future development of a public access walkway along the river bank. Natural stream bank techniques will be employed to the extent practicable. All remedial and restoration work will comply with the substantive requirements of ECL Article 15 and 6 NYCRR Part 608.

8. Institutional Controls:

Imposition of institutional controls in the form of environmental easements for the controlled properties that:

- require the remedial party or site owner to complete and submit to the Department a periodic certification of institutional and engineering controls in accordance with Part 375-1.8(h)(3);
- allow the use and development of the controlled property for industrial use, except for areas where public access will be provided, which will be commercial use, as defined by Part 375-1.8(g), although land use is subject to local zoning laws;
- restrict the use of groundwater as a source of potable or process water, without necessary water quality treatment as determined by the NYSDOH or Dutchess County DOH; and
- require compliance with the Department approved Site Management Plan.

9. Site Management Plan

A Site Management Plan is required, which includes the following:

1. an Institutional and Engineering Control Plan that identifies all use restrictions and engineering controls for the site and details the steps and media-specific requirements necessary to ensure the following institutional and/or engineering controls remain in place and effective:

Institutional Controls:

The Environmental Easement discussed in Paragraph 8 above.

Engineering Controls:

- The cover system discussed in Paragraph 7 above;
- The solidified soils discussed in Paragraph 5 above;
- The sediment cap discussed in Paragraph 6 above; and
- The coal tar recovery system discussed in Paragraph 4 above.

This plan includes, but may not be limited to:

- o an Excavation Plan which details the provisions for management of future excavations in areas of remaining contamination;







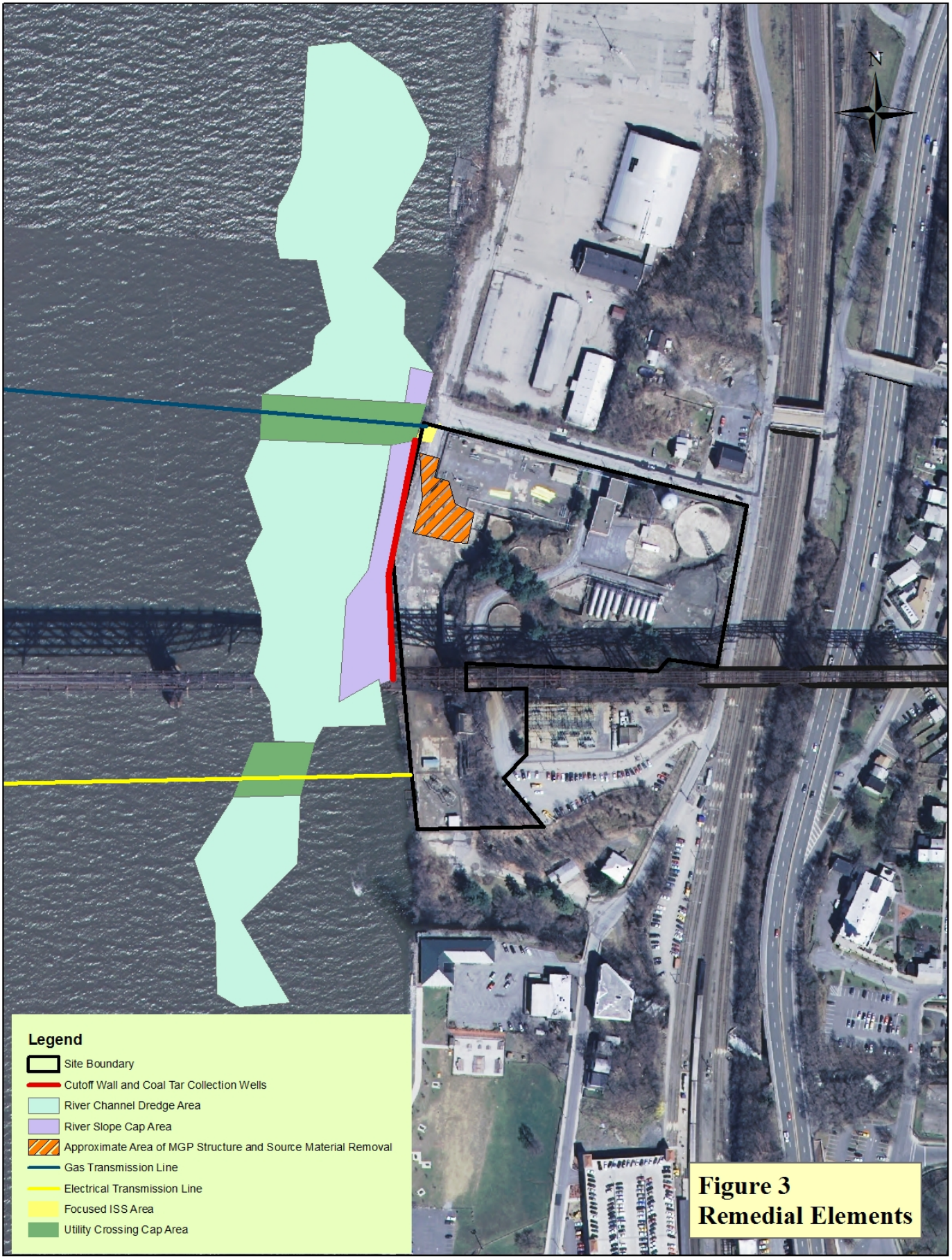

- o descriptions of the provisions of the environmental easement including any land use, and groundwater use restrictions;
 - o a provision for evaluation of the potential for soil vapor intrusion if the current building becomes occupied or if new buildings are developed on the site in the future, including provision for implementing actions recommended to address exposures related to soil vapor intrusion;
 - o provisions for the management and inspection of the identified engineering controls;
 - o maintaining site access controls and Department notification; and
 - o the steps necessary for the periodic reviews and certification of the institutional and/or engineering controls.
2. a Monitoring Plan to assess the performance and effectiveness of the remedy. The plan includes, but may not be limited to:
- o monitoring of groundwater to assess the performance and effectiveness of the remedy;
 - o a schedule of monitoring and frequency of submittals to the Department;
 - o monitoring for vapor intrusion for any occupied existing or future buildings developed on the site, as may be required by the Institutional and Engineering Control Plan discussed above.
3. an Operation and Maintenance (O&M) Plan to ensure continued operation, maintenance, optimization, monitoring, inspection, and reporting of any mechanical or physical components of the remedy. The plan includes, but is not limited to:
- o procedures for operating and maintaining the remedy;
 - o compliance monitoring of treatment systems to ensure proper O&M as well as providing the data for any necessary permit or permit equivalent reporting;
 - o maintaining site access controls and Department notification; and
 - o providing the Department access to the site and O&M records.



Figure 2:
Site Features



Legend

-  Site Boundary
-  Cutoff Wall and Coal Tar Collection Wells
-  River Channel Dredge Area
-  River Slope Cap Area
-  Approximate Area of MGP Structure and Source Material Removal
-  Gas Transmission Line
-  Electrical Transmission Line
-  Focused ISS Area
-  Utility Crossing Cap Area

**Figure 3
Remedial Elements**

Appendix B

Community Environmental Response Plan



Environment

Prepared for:
Central Hudson
Gas and Electric Cooperation
Poughkeepsie, New York

Prepared by:
AECOM
New York, New York
February 2018

Community and Environmental Response Plan (CERP)

**Former North Water Street Manufactured Gas Plant Site
Poughkeepsie, New York
Site ID No. C314070**

Contents

1.0 Introduction.....	1-1
2.0 Public Communication and Outreach	2-1
2.1 CHGE Contact Information.....	2-1
2.2 Document Repositories	2-1
2.3 Regulatory Agency Contact Information	2-1
3.0 Community Air Monitoring Plan (CAMP).....	3-1
4.0 Public Protection Measures	4-1
4.1 Warning Signs.....	4-1
4.2 Street Closure	4-1
4.3 Site Fencing	4-1
5.0 Odor, Vapor, and Dust Control.....	5-1
5.1 Odor and Vapor Control	5-1
5.2 Dust Control	5-1
6.0 Construction Noise Mitigation	6-1
7.0 Vibration Monitoring	7-1
8.0 Pre and Post-Construction Survey Program	8-1
9.0 Site Security.....	9-1
9.1 Perimeter Security	9-1
9.2 Equipment Security.....	9-1
9.3 Off-Hours Security	9-1
10.0 Erosion and Sediment Control Measures	10-1
10.1 Implementation of Erosion Control Measures	10-1
10.2 Stormwater Runoff Control.....	10-1
11.0 Waste Management.....	11-1

12.0 Water Management and Treatment Measures 12-1
 12.1 Wastewater Management and Treatment 12-1

13.0 Transportation Plan..... 13-1
 13.1 Truck Controls..... 13-1

List of Appendices

- Appendix A Community Air Monitoring Plan (CAMP)
- Appendix B Odor, Vapor, and Dust (OVD) Control Plan
- Appendix C Noise Monitoring Plan
- Appendix D Vibration and Settlement Monitoring Plan
- Appendix E Land and Marine Transportation Plan

List of Acronyms

bgs	below ground surface
CAMP	Community Air Monitoring Plan
CERP	Community and Environmental Response Plan
CHGE	Central Hudson Gas & Electric Corporation
MGP	Manufactured Gas Plant
NYSDEC	New York State Department of Environmental Conservation
NYSDOH	New York State Department of Health
OVD	Odor, Vapor, and Dust
Site	Former North Water Street MGP site, Poughkeepsie, Dutchess County, New York
SPDES	State Pollutant Discharge Elimination System
VOCs	Volatile Organic Compounds

1.0 Introduction

AECOM USA, Inc. (AECOM), on behalf of Central Hudson Gas & Electric Corporation (CHGE), has prepared this Community and Environmental Response Plan (CERP) to summarize the controls, monitoring, and work practices that will be implemented during the remedial activities at the former North Water Street Manufactured Gas Plant (MGP) site (site) to address the potential for short-term impacts to the surrounding community or environmental resources. The remedial activities will include installation of a subsurface barrier/bulkhead wall, limited excavation, non-aqueous phase liquid (NAPL) recovery well installation, removal of on-site and in-river visibly contaminated source material, capping of sediments to prevent NAPL migration, management and offsite transportation of impacted materials, restoration, placement of Institutional Controls and preparation and implementation of Site Management Plan (SMP). The site is located in Poughkeepsie, Dutchess County, New York.

The CERP is a concise summary of the controls, monitoring, and work practices, and how they combine to provide the necessary protection of the community and ecological resources. Additional details regarding how these controls will be implemented and will be contained in the project's Design Package. The purpose of the CERP is to provide members of the community with information on the steps and programs that have been put in place in order to protect their health and minimize the disturbance caused by construction activity. This effort will be performed under the approval and oversight of the New York State Department of Environmental Conservation (NYSDEC) and the New York State Department of Health (NYSDOH).

This CERP has been prepared in accordance with the NYSDEC Decision Document (March 2016) and NYSDEC Division of Environmental Remediation (DER)-10.

2.0 Public Communication and Outreach

2.1 CHGE Contact Information

If members of the community have questions or wish to report a concern (non-emergency), they can contact CHGE on the Project Hotline Telephone that will be developed for the project. For an emergency 911 should be contacted.

2.2 Document Repositories

CHGE has established local document repositories for site-related documents. Site documents are available to the community to review throughout the remedial program at the following locations:

Adriance Memorial Library
93 Market Street
Poughkeepsie, NY 12601
phone: (845) 485-3445

NYSDEC
21 South Putt Corners Road
New Paltz, NY 12561
phone: (845) 256-3000

2.3 Regulatory Agency Contact Information

The remedial activities at the site are being performed under the oversight of the NYSDEC. The contact information for the NYSDEC and other regulatory agencies involved in providing oversight for the remedial work being performed at the site are presented below.

New York State Department of Environmental Conservation

Doug MacNeal
Division of Environmental Remediation
625 Broadway
Albany, NY 12233-7014
(518) 402-9662
douglas.macneal@dec.ny.gov

New York State Department of Health

Kristin Kulow
Public Health Specialist
Bureau of Environmental Exposure Investigation
Empire State Plaza-Corning Tower Room 1787
Albany, New York 12237
518-402-7860
kristin.kulow@health.ny.gov

3.0 Community Air Monitoring Plan (CAMP)

A site-specific CAMP is provided in Appendix A. The CAMP shall be enforced 24 hours a day, 7 days a week during the course of the project. The intent of the CAMP is to provide a measure of protection for the downwind community (i.e., off-site receptors including residences and businesses, and on-site workers) from potential vapors and dust carried in the air as a direct result of remedial work activities on the site. The CAMP provides air monitoring procedures, contamination concentration limits, and procedures to reduce vapor and dust generation if the limits are approached.

During construction activities which may create dust or vapors (excavation, dredging, drilling, etc.) fence line perimeter air monitoring will be conducted using a combination of real-time (continuous and almost instantaneous) fixed locations and walk-around supplemental air monitoring using hand-held instruments on an as-needed basis. Contaminants commonly found at former MGP sites will be monitored, including volatile organic compounds (VOCs) and dust. VOCs are chemicals that easily enter the air as gases from some solids or liquids. During excavation at the site, VOCs could potentially enter the air from the chemicals in the contaminated soils.

The CAMP includes a Contingency Plan that defines the different concentration limits, and specific response activities to be implemented during working hours if the limit for a measured compound is exceeded. The response actions, potentially including work stoppage, are intended to prevent or significantly reduce the migration of contaminants carried in the air from the site.

The real-time perimeter limits consist of alert limits and action limits. An alert limit is a level of contaminant in the air that triggers a response action. An alert limit does not suggest the existence of a health hazard, but serves instead as a screening tool to take action, if necessary, to assist in minimizing contaminants from moving off site and away from remediation areas through the air. An action limit is a level of contaminant or odor in the air that triggers work stoppage.

4.0 Public Protection Measures

CHGE and their Contractor will implement a number of plans to protect the public from physical hazards at the site. Each of these measures is designed to make the area surrounding the remediation safe for the general public.

4.1 Warning Signs

The Contractor will place signs at the site entrance on Dutchess Avenue as well as on the southern portion of the site near the Walkway Over the Hudson elevator indicating that the property is being remediated by CHGE under the oversight of the NYSDEC. In addition, signs will be placed indicating that the property is an active construction site and only authorized personnel are allowed onto the property. A perimeter will be established beyond the in-river exclusion zone during the in-river remedial activities and appropriate signage will be placed to warn the public about the activities. Security may be present at the site during non-working hours to prevent access as discussed in Section 9.

4.2 Street Closure

Street closures are not anticipated to be required during the implementation of the remedial activities. Flaggers will be present to direct truck traffic coming in and out of the property.

4.3 Site Fencing

Construction fencing will encompass the entire remedial area and staging areas on the land side for the Contractor. As discussed in Section 8, temporary fencing will also be constructed around excavations. The perimeter fencing is intended to prevent public access to the construction site. This fencing will be monitored during non-working hours by site security as described in Section 9.

5.0 Odor, Vapor, and Dust Control

Odor, vapor, and dust control will be required for this project due to the immediate proximity of industrial, commercial, and residential buildings and public use areas. Engineering controls, as described below, will be applied during the excavation, dredging, and handling of soils and sediments. The Odor, Vapor, and Dust Control Plan is included as Appendix B of this report. A summary of the Plan is presented below.

5.1 Odor and Vapor Control

If the real-time perimeter limits are exceeded or significant nuisance odors are noted adjacent to the excavations or dredging areas, CHGE, the Construction Manager, and the Contractor will consult to determine what type of emission control action is appropriate. Actions that may be taken to reduce contaminant or odor levels include the following:

- Spraying water on exposed soil surfaces and/or roadways to reduce windblown dust.
- Covering working areas of exposed impacted soils, trucks loaded with impacted soils, decant barge with sediments, or stockpiles of impacted soils and sediments with tarpaulin covers, vapor reducing foam, or other vapor control agents.
- Temporarily relocating work to an area with potentially lower emission levels.
- Reduce the production rate or change the sequence of work activities.
- Change the work methods or equipment to alternatives that reduce the potential to create dust or release contaminants into the air.
- Using specialized odor suppressing foams or Biosolve[®] to cover the contaminated soils or sediments. The foam is a product which reduces the ability of vapors and dust to enter the air.

In practice, these actions will typically be used proactively to prevent alert levels from being reached at the site perimeter.

5.2 Dust Control

Construction activities will be performed so as to limit the creation of dust. Dust control measures will be used to minimize the potential for creating dust during soil excavation and handling, and the placement of clean fill. Minimal dust generation is expected during sediment dredging activities due to wet conditions. The Contractor will provide materials to help prevent generating dust which may include tarps and/or water, specialized foams, or other CHGE-approved methods. The Contractor will keep sufficient materials on site to help reduce the level of dust from the excavation and stockpiles of soils and sediments. The material will be stored near the excavation and will be easily mobile in case of need.

Truck routes on site will be inspected continuously during periods of high truck traffic for excessive dirt or dust. Heavily traveled truck routes on the site will be wet down to minimize dust emissions.

The cleaning of trucks exiting the Exclusion Zone will help eliminate dusty conditions on the site. Transport trucks exiting the Exclusion Zone will pass through an inspection area and be inspected to

ensure tires and undercarriages are clean and that tarps are secured. Excessive mud and loose dirt observed on the trucks will be manually removed with brooms and brushes as necessary. The proper cleaning of trucks exiting the site will aid in minimizing/ eliminating dust leaving the site. A decontamination pad large enough to accommodate equipment and truck traffic will be constructed at the exit point to clean tires of transport trucks exiting the site. Sediments will also be covered before being transported on the barges to the treatment and disposal facilities.

6.0 Construction Noise Mitigation

The activities conducted on the site will conform to the local and state noise codes. The Noise Monitoring Plan is included as Appendix C of this report. A summary of the Plan is presented below.

Work will be conducted at times on days as mandated by local rules and regulation and permit requirements. In the event of special or emergency circumstances that require work to be conducted outside the permitted time, the Contractor will obtain after hours work authorization.

The work that will be completed does not currently require the Contractor to perform tasks which are commonly associated with extreme levels of noise. However, some common construction sounds will be heard from the site, including installation of bulkhead piles, truck traffic sounds and engine noises and backup alarms.

If noise issues do become a concern the Contractor may also locate pieces of machinery on the site to maximize the distance from potential receptors and utilize additional sound barriers as needed. This should include levels of measureable noise which may trigger the need for alternative construction methods or shut down the operation resulting in the noise.

7.0 Vibration Monitoring

It is not anticipated that the remedial activities at the project site will generate high levels of vibrations outside of the site boundary. However, the barrier wall installation will require the Contractor to perform tasks that are commonly associated with high levels of vibration (pile driving).

The Vibration and Settlement Monitoring Plan is included as Appendix D of this report. A summary of the Plan is presented below:

The most common source of vibrations from the site will be from the pile driving and compaction equipment, which will be used to install the sheet piles and tighten together layers of clean backfill as it is used to replace impacted soil that has been excavated, respectively. Pile driving equipment, including a high frequency vibratory hammer, uses vibrations to vertically drive sheet piles into the ground. Compaction equipment tightens soil by creating vibrations over a very small area; however, the compaction equipment that will be used on this site is not expected to cause damage to nearby structures.

The Engineer (AECOM) will complete a thorough review of the means and methods selected by the Contractor to perform the required work. If vibrations are substantial, a vibration reduction plan will be put in place for the project site.

Vibration monitoring will be performed by AECOM, who has specialized training and equipment to measure vibrations which travel through the ground. Typically, when called for, small vibration monitoring devices are placed at the project site boundary and near sensitive infrastructure (i.e. underground utilities) to measure vibrations. One of the most commonly used instruments to measure vibrations on construction sites is manufactured by the InstanTel Company and the equivalent will be utilized during this project. (Visit <http://www.instanTel.com> for more information on these devices). For most types of structures there are guidelines available on acceptable vibration levels that should pose no risk of cosmetic or structural damage, which can be used as a maximum limit on vibrations for the work. These include levels of measureable vibration which may trigger the need for alternative construction methods or shut down the operation resulting in the vibration.

8.0 Pre and Post-Construction Survey Program

Structures such as warehouses and businesses that abut the site, and potentially some that are nearby may be contacted by CHGE to arrange for a pre- and post-construction survey of their property.

A pre-construction survey will be conducted by AECOM. The goal is to document the condition of the property and any structures that are on it prior to the start of work on the site. A survey of this nature is typically conducted on the interior and exterior portion of the structures on a property and can be completed on the order of a few hours, depending on the size and number of the structures to be inspected. Still photos or video recordings may be taken in some places to document pre-existing damage to structures.

A post-construction survey is similar to a pre-construction survey, but is conducted after the completion of work at the site. It is performed to document the condition of structures after the work to serve as a record for damages caused, if any, by the nearby construction.

An individual report will be sent to each property owner containing the findings of any pre-construction or post-construction surveys conducted on their structures. Copies of the pre- and post-construction survey results are kept by CHGE, and can be used as evidence in the event of claims of damage to structures caused by construction related activities. Likewise the survey results can also be used to defend the Contractor against false damage claims.

9.0 Site Security

The objectives of the site security plan are to prevent the vandalism/destruction/theft of construction equipment, prevent access, and minimize health and safety concerns for the surrounding neighborhood.

9.1 Perimeter Security

A temporary fence will be erected around the perimeter of the excavations and around the site with a minimum height of at least 6 ft and 8 ft around gas and electric structures. All gates will have the ability to be locked at the end of each work day. If the area is not otherwise lighted (i.e., building floodlights, municipal streetlights, etc.) the Contractor will provide temporary lighting at the gate.

9.2 Equipment Security

All vehicles and/or equipment left on the site will be secured at the end of each working day. Additionally, work trailers and equipment areas will be light overnight. These criteria can be met by vehicles and equipment remaining inside the perimeter fence, or at a secured remote area if left on site overnight or during non-work days. No vehicles or equipment will be left overnight in an unsecured location. The Contractor will insure that all non-essential equipment is de-energized when left on site and not in use to prevent any malfunctions from occurring while workers are not present.

9.3 Off-Hours Security

Security measures may be provided by the Contractor during non-working hours. Lights will be used as needed to maintain secure site conditions.

10.0 Erosion and Sediment Control Measures

The erosion and sedimentation control plan is intended to minimize soil erosion, and control stormwater on the site.

10.1 Implementation of Erosion Control Measures

The Contractor shall install and maintain the following erosion control measures for the duration of the excavation work. Additional erosion control measures may be needed due to events beyond the control of CHGE. The Contractor will install any additional measures necessary to prevent erosion as directed by CHGE.

Containment Berm: Containment Berm will be installed along the perimeter of Temporary Staging Area.

Catch Basin Protection: Catch basin protection will be installed in all catch basins adjacent to the site. The catch basin protection collects sediment that may runoff from the site and prevents it from entering the storm drain system.

Stabilized Construction Entrance: The site entrance and exit will be equipped with a construction entrance; a stabilized pad of aggregate which reduces or eliminates the tracking of sediment onto public streets.

Decontamination Pad: The site exit will be equipped with a decontamination pad, where trucks exiting the site can be washed, removing contaminants and dirt from trucks before they exit the site and travel on public roadways. Truck wash water is collected within the decontamination pad sump and treated by the onsite construction water treatment plant.

10.2 Stormwater Runoff Control

The work does not meet the substantive requirements of a SPDES General Permit for Stormwater Discharges from Construction Activity (GP-02-01). Erosion will be prevented and sediment will be controlled during all on-site earthwork activities in accordance with the applicable New York State guidance. Stormwater run-off will be controlled to prevent contact with impacted soils. Any stormwater that does contact impacted soils will be diverted to the temporary water staging area. Hay bales, silt fence, and rip rap will be used as necessary to prevent erosion of exposed soils.

Detailed plans and specifications for erosion and sediment control are provided in the Remedial Design/Remedial Action Work Plan.

11.0 Waste Management

This section identifies the procedures for managing, treatment, and disposal of waste materials generated as a result of the remedial activities. All wastes removed from the site will be transported from the site by properly permitted and/or licensed waste haulers directly to the CHGE-approved disposal facilities. All trucks and barges will be inspected to ensure the proper placards, decals and permits are displayed. Trucks will utilize the approved truck route and the most direct hauling route to the disposal facility and barges will also use approved waterways to haul the sediments to the approved treatment facility.

MGP-impacted soils removed from excavations will be directly loaded into trucks and MGP-impacted sediments will be loaded on the barges for shipment to the approved treatment facility. MGP-impacted soils will be stock-piled on-site and covered when direct loading is not possible. Prior to transport to the treatment facility, the MGP-impacted sediments will be left on the barges overnight to decant water, which will be transferred and treated in the on-site waste water treatment system. Trucks will not be allowed to stage on local roadways. The Contractor will schedule trucks in a manner that will minimize the wait time for loading.

Vehicles containing excavated soils and barges containing sediments will be covered with a solid plastic tarp. If necessary, spray-on odor suppressing materials such as Rusmar Foam may be used to reduce potential VOC emissions or odors during transit.

The impacted materials may be shipped to a thermal desorption treatment facility or to a landfill. At the thermal desorption facility the impacted soils and sediments are placed in a rotary kiln that heats the soil which volatilizes the organic contaminants in the soil. The contaminant laden vapors are then collected and treated at the facility. The treated soil is then re-used for beneficial uses such as cover materials at landfills or as aggregate for asphalt or concrete. Alternatively, the excavated soils and dredged sediments may also be disposed off-site at an approved landfill facility.

12.0 Water Management and Treatment Measures

12.1 Wastewater Management and Treatment

Wastewater associated with decontamination activities and stormwater on the site will be stored within appropriate containers onsite and transported offsite for disposal during the land-side excavation or stored on-site and treated at the on-site wastewater treatment system during dredging operations. Groundwater is not expected during the shallow excavation at the site. The decant water from the sediments will be transferred to the on-site wastewater treatment system from the barges before the sediments are shipped to an off-site treatment facility. The decant water will be treated and discharged into the Hudson River under the NYSDEC State Pollution Discharge Elimination System (SPDES) permit.

13.0 Land and Marine Transportation Plan

The purpose for the Land and Marine Transportation Plan at the site is to describe the objectives for traffic control and address any potential concerns. The transportation plan is currently being prepared and will be submitted prior to start of construction for informational purposes. The Transportation Plan will indicate the land and marine traffic routes and traffic management at the site for:

- Trucking soil and bulky waste off site
- Barging sediment offsite
- Importing clean fill to the site
- Marine traffic controls during sediment dredging
- Liquid waste hauler picking up construction liquids
- Contractor access and parking
- Equipment access and storage
- Traffic control at the site entrance
- Requirements for truck flagmen/safety spotters on site

The Contractor will provide traffic control personnel when all trucks are exiting the site onto Dutchess Avenue. Traffic control personnel will also direct traffic as needed upon delivery of equipment, trailers, excavation support materials, etc. To maintain access and lines of sight, the Contractor will arrange for and coordinate with the appropriate local authorities to ensure that on-street parking nearest to the entrance/exit gate is limited throughout the duration of the work. Trucks will not be allowed to queue on local streets; however, the Contractor may negotiate with a third party to obtain off-site parking where vehicles can wait to be loaded. All the roadways utilized by the Contractor during the work will be checked daily for spillage and seepage, and cleaned to the satisfaction of CHGE, as necessary.

13.1 Truck/Barge Controls

All material hauled to and away from the site will be performed by companies that are appropriately licensed in all applicable states to perform such work. Additionally, all truck drivers must read and sign a truck driver orientation training program that will occur prior to start of construction activities or as new truck drivers are brought to the site.

Upon arrival to the site, each truck will be visually inspected to ensure appropriate permits are in place. The truck will be initially lined with polypropylene plastic tarp along their beds to prevent water from seeping out of the soil onto local streets. When applicable, odorous truck loads of soil will be sprayed with odor suppressant foam or Biosolve[®] to control odors. The trucks will also utilize a heavy tarp which will be extended over the cargo area and overlap the sides and rear of the cargo area to prevent soil being removed from the truck by wind. Before each vehicle leaves the site it will pass through a decontamination station as described in subsection 4.1. Sediments on the barges will also be covered with a tarp before being transported to an off-site facility for treatment. The detailed transportation plan for the sediment transport will be prepared and submitted for informational purposes prior to any sediment related work at the site.

Appendix A of CERP

Community Air Monitoring Plan (CAMP)



Environment

Prepared for:
Central Hudson
Gas and Electric Corporation
Poughkeepsie, New York

Prepared by:
AECOM
New York, New York
February 2018

Community Air Monitoring Plan

**Former North Water Street Manufactured Gas Plant Site
Poughkeepsie, New York
Site ID No. C314070**

Contents

1.0 Introduction.....	1-1
2.0 Constituents of Concern and Action Levels.....	2-1
2.1 Constituents of Concern	2-1
2.2 Action Levels	2-1
2.3 Site Conditions and Responses	2-1
2.3.1 Alert Level Condition.....	2-2
2.3.2 Action Level Condition	2-2
2.3.3 Shutdown Level	2-3
3.0 Air Monitoring Equipment and Methods	3-1
3.1 Real-Time Monitoring	3-1
3.1.1 Total VOC Monitoring	3-1
3.1.2 Particulate Monitoring	3-2
3.1.3 Odor Monitoring	3-2
4.0 Emission Control Plan	4-1
5.0 Data Management and Reporting	5-1

List of Appendices

Appendix A NYSDOH Generic Community Air Monitoring Plan

List of Tables

Table 2-1	Action and Alert levels for the Remedial Activities	2-1
Table 2-2	Parameter Concentrations and Associated Site Condition Levels	2-2

List of Figures

Figure 2-1 Site Conditions and Associated Responses

List of Acronyms

BTEX	benzene, ethylbenzene, toluene, and xylene
CAMP	Community Air Monitoring Plan
CHGE	Central Hudson Gas & Electric Corporation
COCs	Constituents of Concern
CSM	Chip Measurement System
DER	Division of Environmental Remediation
DNAPL	dense non-aqueous phase liquid
ft bgs	feet below ground surface
HDPE	High Density Polyethylene
MGP	Manufactured Gas Plant
NYSDEC	New York State Department of Environmental Conservation
NYSDOH	New York State Department of Health
PAHs	Polycyclic Aromatic Hydrocarbons
PID	Photoionization Detector
ppmv	parts per million by volume
RPM	Respirable Particulate Matter
Site	Former North Water Street MGP site, Poughkeepsie, Dutchess County, New York
SMP	Site Management Plan
$\mu\text{g}/\text{m}^3$	micrograms per cubic meters
UV	Ultraviolet
VOCs	Volatile Organic Compounds
TVOCs	Total Volatile Organic Compound

1.0 Introduction

This document provides the Community Air Monitoring Plan (CAMP) that will be implemented during the remedial activities at the Former North Water Street Manufactured Gas plant (MGP) site (Site) located in Poughkeepsie, Dutchess County, New York. This CAMP has been prepared by AECOM Environment (AECOM) on behalf of Central Hudson Gas & Electric Corporation (CHGE) to present the methods and procedures that will be used to evaluate air quality in the immediate vicinity of the Site during remedial activities.

Dutchess Avenue is located immediately north of the Site, North Water Street and Amtrak railroad lines are located immediately east of the site, the Hudson River is located immediately west of the Site, and the City of Poughkeepsie Upper Landing Park and Fall Kill Creek is located just south of the Site (Figures 1 and 2). To the north of Dutchess Avenue lies a property currently under redevelopment, which is the site of the former A.C. Dutton Lumber Yard (NYSDEC Site No. C314081).

The remedial activities will include installation of a subsurface barrier/bulkhead wall, limited excavation of upland source material, installation of non-aqueous phase liquid (NAPL) recovery/monitoring wells, removal of on-site and in-river visibly contaminated source material, capping of sediments to prevent NAPL migration, management and offsite transportation of impacted materials, restoration, placement of Institutional Controls and preparation and implementation of Site Management Plan (SMP).

The objectives of this CAMP are to:

- Provide data on a real-time basis so that potential emission sources can be identified and controlled in a timely manner to be protective of off-site receptors.
- Collect appropriate data to document compliance with the Action Levels determined by the New York State Department of Health (NYSDOH) to be protective of off-site receptors.

The community air monitoring program will be performed at upwind and downwind locations around the perimeter of the Site, and will measure the concentrations of the indicator parameters required by NYSDOH during all ground-intrusive activities, including site preparation work, upland excavation, barrier/bulkhead wall installation, and dredging activities. A copy of the NYSDOH generic CAMP is provided as Appendix A.

2.0 Constituents of Concern and Action Levels

2.1 Constituents of Concern

The Site is known to have subsurface impacts dating from the Site's historical use. The primary constituents of concern (COCs) include benzene, ethylbenzene, toluene, and xylene (BTEX compounds) and naphthalene. Their potential contribution to fugitive emissions from remedial activities will be addressed through the monitoring of total volatile organic compound (TVOC) levels.

MGP residuals also contain higher molecular weight polycyclic aromatic hydrocarbons (PAHs) that are significantly less volatile than the COCs discussed above, and have generally been adsorbed onto soil/sediment particles. The potential contribution of these constituents to fugitive emissions will be addressed through the monitoring of respirable particulate matter (RPM₁₀) levels.

Odors, though not necessarily indicative of high constituent concentrations, could create a nuisance, and will be monitored and controlled to the extent practicable.

2.2 Action Levels

NYSDOH has established Action Levels for the principal monitoring parameters, i.e. TVOC and RPM₁₀, to identify conditions when the use of additional control measures may be warranted. An Action Limit is the parameter concentration that, when exceeded, requires a work stoppage and corrective action prior to continuing remedial activities at the site. Note that the program has incorporated an additional Action Level for benzene since it is a specific indicator parameter for MGP residuals that can be effectively monitored on a real-time basis.

The program will also use an Alert Level (75% of the Action Level) for the parameters discussed above to facilitate the effective management of site conditions. The Alert Limit is the parameter concentration that, when exceeded, triggers the use of response actions such as the use of water spray or odor suppressant foam, without a work stoppage. The Alert/Action Levels for the program are summarized in Table 2-1.

Table 2-1 Action and Alert Levels for the Remedial Activities

Parameter	Alert Level	Action Level
TVOC – ppmv	3.7	5.0
Benzene	0.8	1
RPM ₁₀ - µg/m ³	100	150

Note: Limits are the detected concentrations minus background.

2.3 Site Conditions and Responses

The use of Alert and Action Levels as site management tools provides for the following definitions of site conditions:

- **Operational Level:** Concentrations of all parameters (minus background) are less than the Alert Limit.
- **Alert Level:** Concentration of at least one parameter (minus background) is greater than Alert Limit, but do not exceed the Action Limit.
- **Action Level:**
 - TVOCs: Concentration is greater than the Action Limit, but does not exceed 25 parts per million by volume (ppmv).
 - Benzene: Concentration is greater than the Action Limit.
 - RPM₁₀: Concentration is greater than the Action Limit.
- **Shut Down:** Remedial activities must cease if the TVOC level exceeds 25 ppmv.

The site conditions levels are summarized in Table 2-2, with a summary of the associated monitoring requirements/activities provided in Figure 2-1

Table 2-2 Parameter Concentrations and Associated Site Condition Levels

Parameter	Operational Level	Alert Level	Action Level	Shut Down
TVOC – ppmv	$[C] \leq 3.7$	$3.7 < [C_{avg}] \leq 5.0$	$5.0 < [C_{avg}] \leq 25$	$[C_{avg}] > 25$
Benzene- ppmv	$[C] \leq 0.8$	$0.8 < [C_{avg}] \leq 1.0$	$[C_{avg}] > 1$	
RPM ₁₀ - $\mu\text{g}/\text{m}^3$	$[C] \leq 100$	$100 < [C_{avg}] \leq 150$	$[C_{avg}] > 150$	

Note: Levels are the detected concentrations minus background.

2.3.1 Alert Level Condition

In the event that the 15-minute average parameter concentration at the downwind location is greater than the Alert Limit, the contractor will be notified of elevated results and a possible Alert Level site condition. The result will then be compared to the corresponding upwind value to determine if the Alert Level condition is due to remedial activities. If so, the Alert Level condition will be verified and remain in effect as long as the 15-minute average parameter concentration (above background) is greater than the Alert Level but does not exceed the Action Limit.

Under an Alert Level condition, intrusive site work may continue but response actions must be implemented to reduce the elevated parameter concentrations. Example response actions are presented in Section 4. Note that the use of appropriate response actions will also be required upon detection of odors or visible dust at the site perimeter.

A meeting of appropriate site staff, e.g., Construction Manager and Contractors, as well as CHGE or its representative and NYSDEC, if present will be held within 30 minutes of the Alert Level site condition if the elevated results are not mitigated by the initial response actions.

2.3.2 Action Level Condition

An Action Level condition will go into effect if the average 15-minute parameter concentration at the downwind location exceeds the Action Limit. The result will then be compared to the corresponding upwind value to determine if the Action Level condition is due to remedial activities. If so, the Action

Level condition will be verified and remain in effect as long as the 15-minute average parameter concentration (above background) is greater than the Action Level. At this time, the Contractor and CHGE will be notified of an Action Level condition.

Under an Action Level condition, the activities that created the exceedance will be temporarily stopped and one or more response actions (Section 4) will be implemented. A meeting attended by appropriate site staff will be held within 30 minutes of the Action Level notification to review the effectiveness of the initial response and determine if additional actions are required. Work activities may resume provided that the parameter concentrations return to levels that are less than the Action Limit at following locations:

- TVOCs: TVOC levels 200 feet downwind of the exclusion zone or half the distance to the nearest potential receptor or residential/commercial structure, whichever is less – but in no case less than 20 feet
- Dust: the downwind perimeter location

2.3.3 Shutdown Level

For TVOCs, if the concentration is above 25 ppm at the perimeter of the work area, activities must be shutdown until the source of the emissions is identified and controlled.

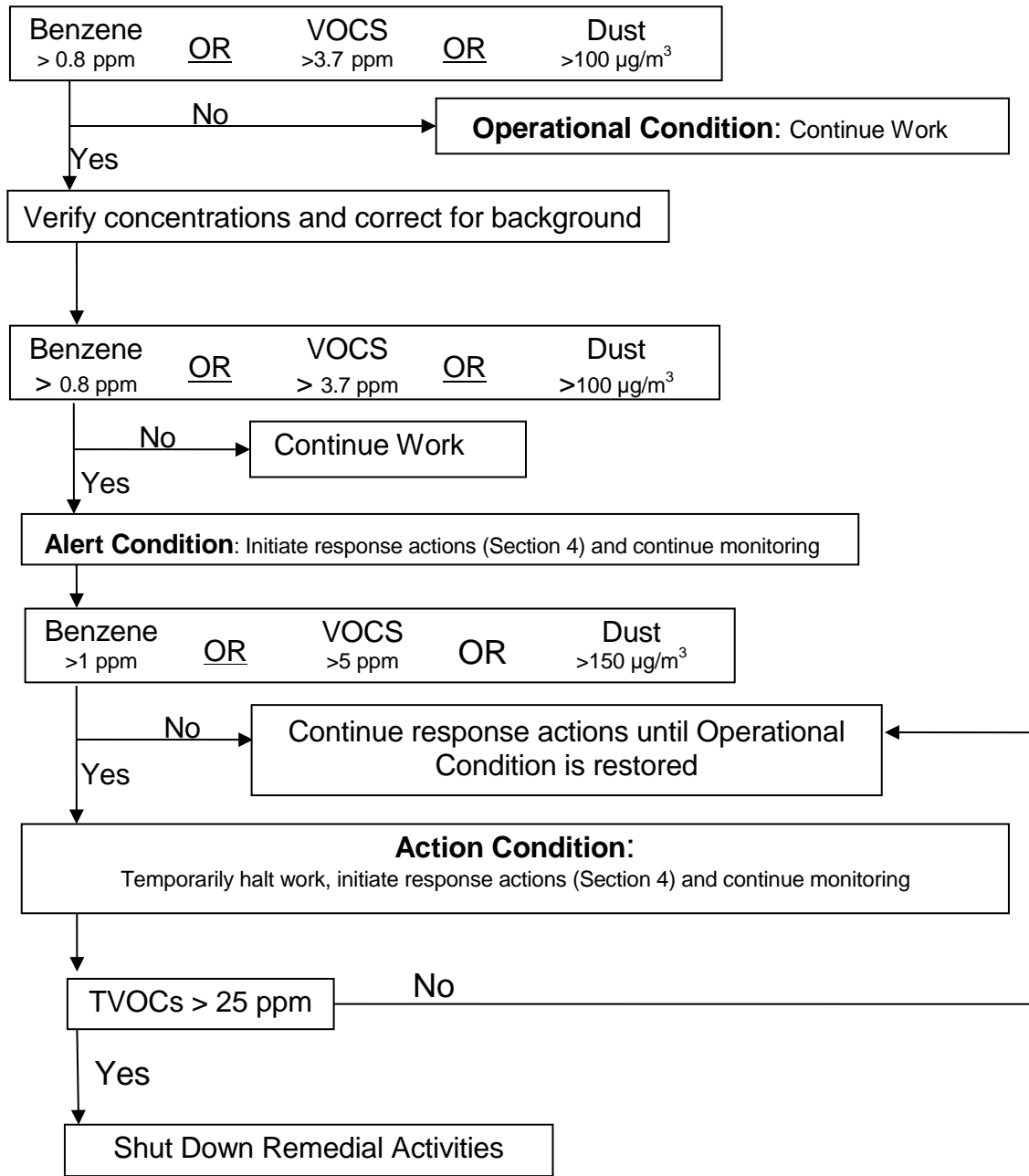

Figure 2-1 Site Conditions and Associated Responses

3.0 Air Monitoring Equipment and Methods

The NYSDOH Generic CAMP requires that real-time monitoring be conducted during ground intrusive activities at sites managed under Division of Environmental Remediation (DER)-10 guidance. The following discussion provides a detailed description of the air monitoring and reporting procedures that will be used during remedial activities at the Site.

3.1 Real-Time Monitoring

Real-time air monitoring for TVOCs and RPM_{10} will be conducted continuously during periods of intrusive activity at upwind and downwind locations along the perimeter of the site. Upwind TVOC concentrations will be measured at the start of each workday and periodically thereafter to establish background conditions. The locations of the instruments may be changed during the day to adapt to changing wind directions.

Portable (battery operated) monitoring stations will be used to collect the real-time data and will include the following components: station case and tripod; total organic vapor analyzer; particulate monitor and data logger. The monitoring data will be converted to 15-minute averages, and will be stored in data-loggers at each location. The averaged values will be compared to the Alert/Action Levels. The units will be equipped with an audible alarm to indicate exceedances of these levels. A portable meteorological station to record wind direction will be installed to accurately locate the up and downwind monitoring points.

3.1.1 Total VOC Monitoring

Ambient concentrations of volatile organic constituents will be measured using a PPB RAE, or equivalent, photoionization detector (PID). PIDs use an ultraviolet (UV) light of appropriate "strength" to ionize the COCs for the site. The associated response will be proportional to the constituent concentration, and will be reported as TVOCs in ppmv.

Instrument calibration procedures will be conducted according to the manufacturer's recommendations. The PID will be zeroed using a sample of ambient air drawn through a canister filled with activated charcoal. The calibration of each PID analyzer will be accomplished using an isobutylene calibration gas of known concentration. The data output will be observed and the response recorded in the field data sheet. Note that moisture, in the form of high humidity can affect instrument sensitivity. If the UV lamp cannot be cleaned, it will be replaced.

Calibrations will be performed at the start of each test day and more frequently as needed. If a unit fails to respond properly to the calibration check procedures, the response will be adjusted to the correct value. If the field technician determines that the instrument has a problem that cannot be resolved by adjustment, the unit will be repaired or replaced.

3.1.1.1 Benzene Monitoring

Additional monitoring for benzene will be conducted in instances when an exceedance of the TVOC Alert Level has been verified. Constituent-specific results will be obtained using a Draeger Chip Measurement System (CSM). Samples will be collected periodically during the Alert/Action conditions to document air quality at the downwind perimeter of the site, and reported as ppmv.

3.1.2 Particulate Monitoring

A MIE PDR-1200/Dustrak dust monitor, or equivalent, will be used to monitor respirable particulate (PM₁₀) levels.

Instrument calibration will be conducted according to the manufacturer's recommendations. At a minimum, each particulate monitor will be field checked daily using zero calibration air. At the beginning of each workday, when site investigation takes place, a calibration check will be performed on each unit at the measurement location. A zero (or particulate-free) test sample, using the appropriate particulate filter supplied by the manufacturer for this purpose, will be placed over the sample inlet. The data output for the monitor will be observed and the response recorded in the field data sheet. Additionally, a weekly upscale or smoke test of each particulate sensor shall be performed and the results recorded in the field data sheet. If the field technician determines that the instrument has a problem, the unit will be repaired or replaced.

Particulate monitoring is based on the measurement principle of near forward light scattering and may be effected by elevated levels of humidity or pollen which may be "counted" as particulate and provide an erroneously high value. During these types of situations the field technician will document atmospheric conditions, e.g. rain, high humidity or elevated pollen or mold spore count as reported by the local weather service.

3.1.3 Odor Monitoring

The disturbance of soil containing MGP residuals can produce odors similar to mothballs, roofing tar, or asphalt driveway sealer. However, the constituent concentrations associated with these odors are typically significantly less than levels that might pose a potential health risk. When odors attributable to the disturbance of impacted media are generated in the work area, observations will also be made at the down-wind limit of the former MGP site in order to assess the potential for off-site issues.

4.0 Emission Control Plan

Several general site management practices will be routinely implemented as primary measures to minimize potential fugitive emissions from remedial activities. They will include efforts to minimize the amount of time that impacted material is exposed to ambient air, and expedite the loading of excavated soil and debris for transport.

However, appropriate secondary measures will be enacted in instances where Alert/Action Level conditions exist or significant MGP odors/visible dust are observed at the perimeter of the site. Secondary controls may include the following:

- The use of temporary tarps or polyethylene covers for stockpiled soils and sediments.
- The use of odor suppressant foam to mitigate VOC emissions or odors. The foam or other agents, such as BioSolve™ or hydro-mulch, may be used where tarps cannot be effectively deployed over the source material, or where tarps are ineffective for controlling emissions.
- The placement of portable barriers close to small active source areas (test pits) can elevate the discharge point of emissions to facilitate dispersion and minimize the effect on downwind receptors. The barriers can be constructed using materials such as plastic “Jersey barriers”, or fence poles and visual barrier fabric/plastic during the land-side excavation. The barriers are placed as temporary two or three-sided structures around active test pit or other intrusive investigation areas, oriented such that the barriers are placed on the upwind and downwind sides of the source. If only one side of the source can be accessed, then the barrier should be placed on the downwind side.

The final selection of controls will be dependent on field conditions encountered. The AECOM field representative will work through the applicable list of secondary controls until the emission issues are resolved, and will work closely with CHGE and NYSDEC during this task. The AECOM field representative, in consultation with CHGE, will also provide information on CAMP monitoring and controls to stakeholders in the community, as required.

5.0 Data Management and Reporting

A field log book and calibration forms will be maintained on-site throughout the field activities. Information to be recorded will include:

- Daily Site maps showing the locations of all monitoring locations
- Dates for sampling equipment installation, operations (including start/stop times) and removal
- Sampling equipment calibration dates, times and results
- Sampling equipment maintenance dates and results
- General field weather conditions (observations of temperature, wind direction, precipitation)
- Description of intrusive activities conducted during periods when elevated data values were recorded
- Descriptions of contingent measures/response actions implemented in response to elevated monitoring results
- Any unusual situations which may affect samples or sampling

The following information will be summarized at the conclusion of each day:

- Averaged TVOC concentrations compared to the Action Levels
- Benzene results (if generated) compared to the Action Levels
- Averaged RPM_{10} concentrations compared to the Action Levels

The following data summaries will be prepared and provided to CHGE on a weekly basis for transmittal to NYSDEC and NYSDOH:

- Compiled 15-minute average concentrations of TVOC and RPM_{10}
- Maximum 15-minute average concentrations of TVOC and RPM_{10}
- Discussion of Alert and Action Limits (minus background concentrations) reached during the week
- Description of corrective actions taken in response to exceedances of Action/Alert Levels or complaints
- Monitoring station location maps

A final end of program data report will be produced summarizing the monitoring operations and data collection results.

Appendix A

NYSDOH Generic CAMP

Appendix 1A

New York State Department of Health Generic Community Air Monitoring Plan

Overview

A Community Air Monitoring Plan (CAMP) requires real-time monitoring for volatile organic compounds (VOCs) and particulates (i.e., dust) at the downwind perimeter of each designated work area when certain activities are in progress at contaminated sites. The CAMP is not intended for use in establishing action levels for worker respiratory protection. Rather, its intent is to provide a measure of protection for the downwind community (i.e., off-site receptors including residences and businesses and on-site workers not directly involved with the subject work activities) from potential airborne contaminant releases as a direct result of investigative and remedial work activities. The action levels specified herein require increased monitoring, corrective actions to abate emissions, and/or work shutdown. Additionally, the CAMP helps to confirm that work activities did not spread contamination off-site through the air.

The generic CAMP presented below will be sufficient to cover many, if not most, sites. Specific requirements should be reviewed for each situation in consultation with NYSDOH to ensure proper applicability. In some cases, a separate site-specific CAMP or supplement may be required. Depending upon the nature of contamination, chemical-specific monitoring with appropriately-sensitive methods may be required. Depending upon the proximity of potentially exposed individuals, more stringent monitoring or response levels than those presented below may be required. Special requirements will be necessary for work within 20 feet of potentially exposed individuals or structures and for indoor work with co-located residences or facilities. These requirements should be determined in consultation with NYSDOH.

Reliance on the CAMP should not preclude simple, common-sense measures to keep VOCs, dust, and odors at a minimum around the work areas.

Community Air Monitoring Plan

Depending upon the nature of known or potential contaminants at each site, real-time air monitoring for VOCs and/or particulate levels at the perimeter of the exclusion zone or work area will be necessary. Most sites will involve VOC and particulate monitoring; sites known to be contaminated with heavy metals alone may only require particulate monitoring. If radiological contamination is a concern, additional monitoring requirements may be necessary per consultation with appropriate DEC/NYSDOH staff.

Continuous monitoring will be required for all ground intrusive activities and during the demolition of contaminated or potentially contaminated structures. Ground intrusive activities include, but are not limited to, soil/waste excavation and handling, test pitting or trenching, and the installation of soil borings or monitoring wells.

Periodic monitoring for VOCs will be required during non-intrusive activities such as the collection of soil and sediment samples or the collection of groundwater samples from existing monitoring wells. "Periodic" monitoring during sample collection might reasonably consist of taking a reading upon arrival at a sample location, monitoring while opening a well cap or

overturning soil, monitoring during well baling/purging, and taking a reading prior to leaving a sample location. In some instances, depending upon the proximity of potentially exposed individuals, continuous monitoring may be required during sampling activities. Examples of such situations include groundwater sampling at wells on the curb of a busy urban street, in the midst of a public park, or adjacent to a school or residence.

VOC Monitoring, Response Levels, and Actions

Volatile organic compounds (VOCs) must be monitored at the downwind perimeter of the immediate work area (i.e., the exclusion zone) on a continuous basis or as otherwise specified. Upwind concentrations should be measured at the start of each workday and periodically thereafter to establish background conditions, particularly if wind direction changes. The monitoring work should be performed using equipment appropriate to measure the types of contaminants known or suspected to be present. The equipment should be calibrated at least daily for the contaminant(s) of concern or for an appropriate surrogate. The equipment should be capable of calculating 15-minute running average concentrations, which will be compared to the levels specified below.

1. If the ambient air concentration of total organic vapors at the downwind perimeter of the work area or exclusion zone exceeds 5 parts per million (ppm) above background for the 15-minute average, work activities must be temporarily halted and monitoring continued. If the total organic vapor level readily decreases (per instantaneous readings) below 5 ppm over background, work activities can resume with continued monitoring.

2. If total organic vapor levels at the downwind perimeter of the work area or exclusion zone persist at levels in excess of 5 ppm over background but less than 25 ppm, work activities must be halted, the source of vapors identified, corrective actions taken to abate emissions, and monitoring continued. After these steps, work activities can resume provided that the total organic vapor level 200 feet downwind of the exclusion zone or half the distance to the nearest potential receptor or residential/commercial structure, whichever is less - but in no case less than 20 feet, is below 5 ppm over background for the 15-minute average.

3. If the organic vapor level is above 25 ppm at the perimeter of the work area, activities must be shutdown.

4. All 15-minute readings must be recorded and be available for State (DEC and NYSDOH) personnel to review. Instantaneous readings, if any, used for decision purposes should also be recorded.

Particulate Monitoring, Response Levels, and Actions

Particulate concentrations should be monitored continuously at the upwind and downwind perimeters of the exclusion zone at temporary particulate monitoring stations. The particulate monitoring should be performed using real-time monitoring equipment capable of measuring particulate matter less than 10 micrometers in size (PM-10) and capable of integrating over a period of 15 minutes (or less) for comparison to the airborne particulate action level. The equipment must be equipped with an audible alarm to indicate exceedance of the action level. In addition, fugitive dust migration should be visually assessed during all work activities.

1. If the downwind PM-10 particulate level is 100 micrograms per cubic meter (mcg/m^3) greater than background (upwind perimeter) for the 15-minute period or if airborne dust is observed leaving the work area, then dust suppression techniques must be employed. Work may continue with dust suppression techniques provided that downwind PM-10 particulate levels do not exceed $150 \text{ mcg}/\text{m}^3$ above the upwind level and provided that no visible dust is migrating from the work area.

2. If, after implementation of dust suppression techniques, downwind PM-10 particulate levels are greater than $150 \text{ mcg}/\text{m}^3$ above the upwind level, work must be stopped and a re-evaluation of activities initiated. Work can resume provided that dust suppression measures and other controls are successful in reducing the downwind PM-10 particulate concentration to within $150 \text{ mcg}/\text{m}^3$ of the upwind level and in preventing visible dust migration.

3. All readings must be recorded and be available for State (DEC and NYSDOH) and County Health personnel to review.

December 2009

Appendix B of CERP

Odor, Vapor, and Dust (OVD) Control Plan



Environment

Prepared for:
Central Hudson
Gas and Electric Corporation
Poughkeepsie, New York

Prepared by:
AECOM
New York, New York
February 2018

Odor Vapor and Dust Control Plan

**Former North Water Street Manufactured Gas Plant Site
Poughkeepsie, New York
Site ID No. C314070**

Contents

1.0 Introduction.....	1-1
2.0 Potential Sources of Fugitive Emissions	2-1
2.1 Remediation Processes.....	2-1
2.1.1 Sheet Pile Installation	2-1
2.1.2 Excavation & Dredging	2-1
2.1.3 Transfer, Storage, and Loading of Material	2-2
2.1.4 Fill Placement.....	2-2
3.0 Site Controls	3-1
3.1 Level I Controls	3-1
3.1.1 Physical Controls	3-1
3.1.2 Site Layout	3-1
3.1.3 Coordination of Disposal	3-2
3.2 Level II Controls	3-2
3.2.1 Suppressing Agents.....	3-2
3.2.2 Tarps	3-3
3.3 Level III Controls	3-3
3.3.1 Production/Schedule.....	3-3
3.3.2 Meteorological Conditions	3-3
3.3.3 Relocation of Activities.....	3-3

List of Appendices

Appendix A Material Safety Data Sheet, AC-900 Series Equipment (PFUs)

List of Tables

Table 3-1 Levels and Response Actions

List of Acronyms

CAMP	Community Air Monitoring Plan
CHGE	Central Hudson Gas & Electric Corporation
COCs	Constituents of Concern
DNAPL	dense non-aqueous phase liquid
ft bgs	feet below ground surface
HDPE	High Density Polyethylene
MGP	Manufactured Gas Plant
NYSDEC	New York State Department of Environmental Conservation
OVD	Odor, Vapor, Dust
Site	Former North Water Street MGP site, Poughkeepsie, Dutchess County, New York
VOCs	Volatile Organic Compounds

1.0 Introduction

This Odor, Vapor, and Dust (OVD) Control Plan (the Plan) has been prepared by AECOM USA, Inc. (AECOM), on behalf of Central Hudson Gas & Electric Corporation (CHGE), to provide a summary of potential impact mitigation options that may be implemented to control, reduce, and minimize the effects of potential fugitive emissions resulting from the remedial activities at the Former North Water Street Manufactured Gas Plant (MGP) site (Site) located in Poughkeepsie, Dutchess County, New York. The implementation of the Plan will control fugitive emissions ensuring that the community and workers are not exposed to constituents of concern (COCs) at levels greater than federal, state, and local health-based guidelines. The remedial activities will be implemented according to the New York State Department of Environmental Conservation (NYSDEC) Decision Document (March 2016) to address the residuals remaining from the former MGP operations.

The information presented in the Plan is designed to provide the construction management team with a summary of typical control options and guidance in their implementation. As such, the Plan identifies construction activities that might be potential sources of fugitive emissions, distinctive impacts of odor or dust, and their corresponding control measures.

The potential sources of fugitive emissions are listed in Section 2 while the typical control options are discussed in Section 3. This Plan does not preclude the use of other mitigation technologies or techniques designated in other design documents.

2.0 Potential Sources of Fugitive Emissions

The following section details the potential sources of OVD resulting from the implementation of remedial activities at the Site. Fugitive emissions can be generated from a variety of activities including the remediation processes themselves and/or from the temporary staging of materials for characterization, consolidation, and scheduling for transportation.

Due to the COCs associated with the remedial activities at former MGP sites, fugitive emissions can take the form of volatile organic compounds (VOC's), odor, and/or dust. Dust can be entrained with low levels of high molecular weight constituents, while VOC's can volatilize into ambient air. Odor emissions will result from the atmospheric exposure of impacted media. Experience demonstrates that the potential for odor generation is more significant from Site soils/sediment than from groundwater. Therefore, the discussion of odor generation will be generally limited to activities involving the handling of impacted soils/sediment. It should be noted that the constituent concentrations associated with MGP odors are typically less than the levels that potentially pose a health risk, as the odor threshold of COC's are typically less than health-based action levels.

2.1 Remediation Processes

Remedial activities can generate fugitive emissions through the disturbance/exposure of impacted media, and/or the transfer/transport of materials. The following sections provide an overview of the proposed project site operations, i.e., sheet pile installation, subsurface obstructions removal, excavation, dredging, and transferring and loading of material and their associated emissions.

2.1.1 Sheet Pile Installation

Steel sheeting will be installed along the east bank of the Hudson River as a part of the remedial activities. The entire wall will serve as a structural replacement bulkhead; however, a portion of the wall will also be used as a barrier to prevent further migration of MGP-related residual impacts. Prior to sheet pile placement, the alignment will be pre-cleared to a depth of approximately 3 feet to remove any subsurface obstructions in the shallow soils that would prevent the sheeting from being installed to depth.

See the following section on subsurface obstructions removal for details on potential fugitive dust or VOC/odor emissions.

2.1.2 Excavation & Dredging

The principal sources of potential fugitive emissions during the site remedial action are expected to be:

- Pre-trenching along the barrier/bulkhead wall alignment. A 3-foot wide, approximately 850 foot long, and 3 foot deep trench will be excavated along the barrier wall alignment;
- Soil excavation to remove shallow MGP-impacted soils from up to 2 foot from different areas of the site; and

- Dredging of MGP-impacted sediments from the bottom of the Hudson River from dredge prisms varying in depths to a maximum of 13 feet.

The excavated material will be directly loaded on the trucks or temporarily placed on and covered with 12-mil polyvinyl if stockpiled at the site before loading on the truck for off-site disposal. It is expected that only a 20-30 foot section of the trench will be open at any given time to limit potential fugitive emissions. The excavation material is not anticipated to be heavily impacted with MGP- related residuals. During pre-clearing work water and odor suppressant (Bio-Solve and/or foam) will be on-site and applied as needed to eliminate potential odor and dust emissions. All concrete subsurface structures will be stockpiled on polyvinyl material until it is trucked off-site for disposal.

Material excavated from shallow MGP-impacted areas of the site will be directly loaded in the truck or stockpiled temporarily on polyvinyl as described above. The dredge sediments will be placed in a barge to decant and transported off-site after being covered with a 6-mil tarp. Based on the limited nature of the land-side shallow excavation and wet conditions during dredging, minimal fugitive dust is expected.

Past project experience suggests that fugitive dust from excavation and dredging activities will not generally pose a significant problem and that the intensity of VOC/odor emissions will be highly variable, with the greatest impact occurring when impacted areas are disturbed/exposed. However, in the event air and dust monitoring indicates action levels have been reached or surpassed, an odor suppressant foam (or similar agent) will be utilized as described in the Section 3.2.1.

2.1.3 Transfer, Storage, and Loading of Material

Another source of potential emissions associated with remedial action will be the stockpiling or manual loading of impacted soils and sediments for disposal. Additional consolidation or size reduction of material should be avoided to minimize the source of emissions.

To the extent practicable, the majority of the soils will be directly loaded into trucks for off-site disposal. However, contingent upon work activities and rate of production, it may be necessary to stockpile or stage impacted material for consolidation, characterization, or scheduling of transport. This material has the potential to be an emission source, and stockpile/staging areas will be covered, as required, with 12-mil high-density polyethylene (HDPE) fabric. The sediments will be covered overnight with 12-mil polyvinyl while on the barge for decant and also during transportation to minimize emissions.

2.1.4 Fill Placement

Dust may be generated during fill placement over the project area. Dust will be controlled by spraying with water.

3.0 Site Controls

This section describes site controls that will be implemented during the remedial activities for the minimization and control of fugitive emissions and to ensure that ambient concentrations of COCs remain below federal, state, and local health based guidelines. The mitigation options have been classified into levels to be implemented based on site-specific action levels delineated in the *Community Air Monitoring Plan*, AECOM, February 2018. The actual mitigation measures will be determined in the field by the on-site Construction Manager, who may also choose to implement mitigation measures to avoid reaching the site-specific action levels.

A three-tiered set of controls are proposed for this Plan:

- Level I – Built into the design of the Plan and includes proactive measures to minimize the effect of fugitive emissions. Level I includes air monitoring to ensure that levels of VOCs and dust are under site-specific action levels.
- Level II – Procedures that are implemented in response to specific increases in fugitive emissions but are not likely to have a significant impact in the schedule of remedial activities. Level II controls will be made available on-site at all times.
- Level III – More aggressive procedures, initiated in response to specific increases in fugitive emissions, which are likely to have a more significant impact on production schedule and remedial activities.

The Construction Manager is required to progressively implement these options until emission sources are controlled and ambient concentrations no longer have the potential to pose a health risk. A summary of the proposed controls for processes and storage activities are provided in Table 3-1.

3.1 Level I Controls

Level I Controls are built into the design of the remedial activities and involve physical controls, site layout, and scheduling.

3.1.1 Physical Controls

All stockpiles of impacted material will be covered with 12-mil polyvinyl if left inactive for a period of more than 2 hours.

All trucks and barges used for off-site transport will have 6-mil tarps in place to cover impacted material. On-site haul routes will be routinely wetted using a hose, sprinkler, or dedicated water truck to control dust.

3.1.2 Site Layout

The dispersion of fugitive emissions is controlled by meteorological conditions and their impact generally decreases with distance from the source. If possible, transfer/storage areas will be placed downwind of off-site receptors.

3.1.3 Coordination of Disposal

If characterization by the Engineer will be required for off-site disposal of impacted soils and sediments, the engineers will collect and categorize samples with fast track turnaround time to minimize the amount of time the impacted soils and sediments are staged on-site.

The Contractor will coordinate with all of the selected facilities and schedule transportation to ensure uninterrupted soil and sediment removal from the project site. These actions will allow for direct loading where practicable and minimize stockpiling.

3.2 Level II Controls

Air monitoring will routinely be performed at the fence line of the project site as delineated in the Community Air Monitoring Plan (CAMP) during all work activities. The results will be compared to site-specific action levels for VOC's and total particulates. These presumptive action levels are provided in Table 3-1.

If the action levels are exceeded, additional monitoring will be conducted to confirm the result. Level II controls will be enacted if the exceedance is confirmed. The Construction Manager will then work through the applicable list of site controls until the fence line monitoring results for all parameters are determined to be less than their associated action levels. Specific Level II controls are discussed below.

3.2.1 Suppressing Agents

Several agents that can be applied over emissions sources have been determined to be effective in controlling emissions. These include odor suppressant foam for VOC mitigation and water spray for dust suppression.

The following suppressing agents have been identified for use, but additional agents may be used or substituted for other proven agents such as odex, hydromulch, or ecosorb.

3.2.1.1 Odor Suppressant Foam

Odor suppressant foam can provide immediate, localized control of VOC and odor emissions. The foam is created by the injection of air into a foam concentrate/water mixture using a Pneumatic Foam Unit. The foam is applied via a hose to cover source areas to a depth of 3 to 6 inches. Foam (Rusmar AC-900 or equivalent) is a short term remedy and can be actively used to control VOC and odor emissions from active excavations/stockpiles and during the loading of trucks. It is shipped as a concentrate and diluted with water at the project site. Under normal conditions, this foam can last for several hours. However, it has been observed to degrade quickly in direct sunlight or precipitation, so it must be applied liberally and frequently to all areas that require odor control.

Information regarding the foam and application units is provided in Appendix A.

3.2.1.2 BioSolve

BioSolve can be used as an alternative to or in conjunction with foam. The dilute solution can be sprayed directly onto newly exposed soil surfaces or stockpiles of contaminated material where volatilization is taking place. BioSolve creates an emulsion with the MGP-related residuals thus suppressing vapors, allowing work to continue safely.

3.2.1.3 Water Spray

A spray of water can be used to minimize the amount of dust created. A water hose is effective for controlling dust over a small area, while lawn sprinklers or a dedicated water truck may be more efficient for extended control of large areas or on-site haul routes. Water will be used to control dust during land-side excavation. Due to wet conditions during the sediment dredging, use of water is not anticipated.

3.2.2 Tarps

Tarps can provide effective control for source areas that are likely to be inactive for extended periods of time. To be effective, the size of the source area should be controlled such that it can be covered using a single tarp. Rolls of 6-mil polyethylene will be used to cover inactive source areas. 6-mil Tarps will also be used for covering exposed soils loaded into trucks or sediments loaded on the barges. All trucks will be lined with 10-mil polyethylene sheeting. The liners will be large enough to overlap and fully cover the top of the load. Additional automatic mesh tarps will be used to secure the liners. The sediments on the barges will also be covered with 6-mil tarp prior to being transported off-site for treatment and disposal.

3.3 Level III Controls

Level III controls are to be implemented when Level II controls have been exhausted and ambient concentrations of emissions continue to exceed the site-specific action levels. Each of the control options listed in this subsection has the potential to significantly affect the schedule/production rate of remedial action activities. These delays may be required periodically to ensure that acceptable levels of fugitive emissions are maintained and are preferable to a complete work cessation to control an emission event.

3.3.1 Production/Schedule

It may be necessary to reduce the excavation rate to reduce the surface area of disturbed media or to slow the generation rate of stockpiles. These activities would result in smaller source areas that could be more effectively controlled using Level II techniques. Efficient scheduling/ coordination of operations can also limit the impact of active emission sources. Close coordination of excavation activities can decrease the surface area of disturbed material, thereby reducing the size of the emission source. A smaller source area can facilitate the implementation of additional controls, if required.

3.3.2 Meteorological Conditions

It may be necessary to limit certain activities to those periods when preferred meteorological conditions exist, such as wind direction or low temperatures.

3.3.3 Relocation of Activities

Another option is to temporarily cease work and move the remedial activities to lesser-impacted areas of the project site until adequate control measures can be implemented or more favorable meteorological conditions return.

Tables

**Table 3-1
Levels and Response Actions
OVD Control Plan
Former North Water Street MGP Site
Poughkeepsie, New York**

Site Condition	Response Action
Operational Level: Normal or ambient air-conditions where all target concentrations are less than the Alert Limits (75 percent of the Action Limit)	<ul style="list-style-type: none"> • Normal Site Operations – No Response Action Required
Alert Level: Concentration of at least one target is equal to or greater than Alert Limit (75 percent of the Action Limit), but less than the Action Limit	<ul style="list-style-type: none"> • Establish trend of data and determine if evaluation/wait period is warranted • Temporarily stop work • Temporarily relocate work to an area with potentially lower emission levels • Apply water to area of activity or haul roads to minimize dust levels • Reschedule work activities • Cover all or part of the excavation area • Apply VOC emission suppressant foam over open excavation areas • Slow the pace of construction activities • Change construction process or equipment that minimize air emissions
Action Level: of at least one target is equal to or greater than the Action Limit	<ul style="list-style-type: none"> • Cease construction activities • Assess work activity modifications • Re-evaluate air monitoring work plan
Notes: The bulleted response actions specified under each site condition can be implemented in any order that is most appropriate under the existing site conditions.	

Target Compounds	Alert Limit
TVOCs (15-minute average concentration)*	3.7 ppm greater than background**
Respirable Particulate Matter (RPM ₁₀) (15-min avg)*	100 µg/m ³ greater than background**

Target Compounds	Action Limit
TVOCs (15-minute average concentration)	5 ppm greater than background**
TVOCs (15 minute instantaneous concentration)	25 ppm greater than background**
Respirable Particulate Matter (RPM ₁₀) (15-min conc)	150 µg/m ³ greater than background**
Odor (n-butanol scale) (15-minute sustained)	3 (Verified related to construction)
Odor (nuisance)	Public complaints that are verified to be related to construction
Hydrogen cyanide	1 ppmv

ppmv - parts per million volume

µg/m³ - micrograms per meter cubed

* 15-minute average concentrations updated every 1 minute

** Background is defined as the current upwind 15-minute average concentration.

Appendix A

Material Safety Data Sheet, AC-900 Series Equipment (PFUs)



MATERIAL SAFETY DATA SHEET

LONG DURATION FOAM AC-645

SECTION I: GENERAL INFORMATION

- Manufacturer's Name: RUSMAR INCORPORATED
- Manufacturer's Address: 216 Garfield Avenue • West Chester, PA 19380
- Manufacturer's Phone No.: 610-436-4314
- Chemical Family: Aqueous anionic surfactant mixture
- Trade Name: RUSMAR AC-645

SECTION II: HAZARDOUS INGREDIENTS

- Paints, Preservatives, and Solvents - None
- Alloys and Metallic Coatings - None
- Hazardous Mixtures and Other Materials - None

SECTION III: PHYSICAL DATA

- Boiling Point: 100° C
- Vapor Pressure: 25mm Hg at 25° C
- Vapor Density (Air = 1): N/A
- Water Solubility: Complete
- Appearance/Odor: Translucent, white, milk-like, odorless, viscous liquid
- Specific Gravity: 1.01 to 1.06
- % Volatile, By Volume: None
- Evaporation Rate: N/A

SECTION IV: FIRE AND EXPLOSION HAZARD DATA

- Flash Point (Method): Nonflammable
- Flammable Limits: N/A
- Extinguishing Media: N/A
- Special Fire Fighting Procedures: None
- Unusual Fire and/or Explosion Hazards: None

SECTION V: HEALTH HAZARD DATA

- Threshold Limit Value: Not Determined
- Effects of Overexposure: This material is not expected to present an inhalation or ingestion hazard. It may cause an eye or skin irritation upon direct contact.
- Emergency and First Aid Procedures: Wash thoroughly with clean water



MATERIAL SAFETY DATA SHEET

LONG DURATION FOAM AC-645

SECTION VI: REACTIVITY DATA

- Material is stable
- No material incompatibility
- Hazardous Decomposition Products: Low levels of sulfur oxides on exposure to high temperatures (concentrate). Foam is non-combustible.
- Polymerization will not occur

SECTION VII: SPILL OR LEAK PROCEDURES

- Steps to be taken in case material is released or spilled: If spilled indoors on a hard surface, the spill area may be slippery and should be thoroughly washed with water. Contain spill and absorb material with dirt or other appropriate absorbent.
- Waste Disposal Method: This material is completely biodegradable and can be disposed of in a sanitary landfill according to local regulations.

SECTION VIII: SPECIAL PROTECTION INFORMATION

- Respiratory Protection: None required for normal operations
- Ventilation: No special requirements
- Protective Gloves: Not required, but recommended
- Eye Protection: Not required, but recommended
- Other Protective Equipment: None

SECTION IX: SPECIAL PRECAUTIONS

- Storing/Handling Precautions: Avoid excessive heat. Material will freeze, but thawing will not cause changes in the product.
- Other Precautions: None



MATERIAL SAFETY DATA SHEET

LONG DURATION FOAM AC-900 SERIES

SECTION I: GENERAL INFORMATION

- Manufacturer's Name: RUSMAR INCORPORATED
- Manufacturer's Address: 216 Garfield Avenue • West Chester, PA 19380
- Manufacturer's Phone No.: 610-436-4314
- Chemical Family: Aqueous anionic surfactant, polymer latex mixture
- Trade Name: RUSMAR AC-900

SECTION II: HAZARDOUS INGREDIENTS

- Paints, Preservatives, and Solvents - None
- Alloys and Metallic Coatings - None
- Hazardous Mixtures and Other Materials - None

SECTION III: PHYSICAL DATA

- Boiling Point: 100° C
- Vapor Pressure: 25mm Hg at 25° C
- Vapor Density (Air = 1): N/A
- Water Solubility: Complete
- Appearance/Odor: Opaque, gray, viscous liquid
- Specific Gravity: 1.01 to 1.06
- % Volatile, By Volume: None
- Evaporation Rate: N/A

SECTION IV: FIRE AND EXPLOSION HAZARD DATA

- Flash Point (Method): Nonflammable
- Flammable Limits: N/A
- Extinguishing Media: N/A
- Special Fire Fighting Procedures: None
- Unusual Fire and/or Explosion Hazards: None

SECTION V: HEALTH HAZARD DATA

- Threshold Limit Value: Not Determined
- Effects of Overexposure: This material is not expected to present an inhalation or ingestion hazard. It may cause an eye or skin irritation upon direct contact.
- Emergency and First Aid Procedures: Wash thoroughly with clean water



MATERIAL SAFETY DATA SHEET

LONG DURATION FOAM AC-900 SERIES

SECTION VI: REACTIVITY DATA

- Stability: Material is stable. This material will likely coagulate if frozen.
- Incompatibility: Addition of other materials may cause coagulation
- Hazardous Decomposition Products: Low levels of sulfur oxides on combustion and dense, black smoke
- Polymerization will not occur

SECTION VII: SPILL OR LEAK PROCEDURES

- Steps to be taken in case material is released or spilled: If spilled indoors on a hard surface, the spill area may be slippery and should be thoroughly washed with water. Contain spill and absorb material with dirt or other appropriate absorbent.
- Waste Disposal Method: This material has only a modest BOD and can be deposited in sewers. However, it should be flushed with copious amounts of water. The material can be disposed of in approved landfill; dried waste may be incinerated.

SECTION VIII: SPECIAL PROTECTION INFORMATION

- Respiratory Protection: None required for normal operations
- Ventilation: No special requirements
- Protective Gloves: Not required, but recommended
- Eye Protection: Not required, but recommended
- Other Protective Equipment: None

SECTION IX: SPECIAL PRECAUTIONS

- Storing/Handling Precautions: Avoid excessive heat. Material will freeze, thawing will NOT return product to usable form.
- Other Precautions: None



LONG DURATION FOAM AC-645

GENERAL DESCRIPTION

AC-645 Long Duration Foam is a patented product which produces a thick, long-lasting, viscous foam barrier for immediate control of dust, odors and volatile organic compounds (VOCs). AC-645 is designed for use with Rusmar Pneumatic Foam Units.

AC-645 foam is recognized by the Environmental Protection Agency and the U.S. Army Corps of Engineers as providing superior emission control for a period up to 17 hours. AC-645 has been specified for use at Superfund and other hazardous waste sites across the United States and Canada.

FEATURES

- Biodegradable
- Will not add to treatment costs
- No ambient temperature limitations
- Easy to use
- More effective than tarps
- Non-reactive
- Non-hazardous
- Safe for workers and the environment
- Requires only water dilution
- No clean up necessary
- Non-combustible
- Covers any contamination source

APPLICATIONS

The primary application for AC-645 is control of odors, VOCs and dust during active excavation and for overnight coverage of contaminated soils at hazardous waste sites. AC-645 can also be applied on top of liquid surfaces.

SPECIAL ODOR CONTROL PROBLEMS

The remediation of hazardous waste sites often includes excavation of soil contaminated with odorous compounds. AC-645 has little or no odor itself, although a pleasant wintergreen or vanilla scent can be added. It forms a barrier between contaminants and the atmosphere and can be applied during active excavation to provide an immediate and effective barrier to minimize odors. It is completely biodegradable and poses no threat to workers, neighboring residents or ground water. AC-645 will not add to soil volume or treatment costs.



LONG DURATION FOAM AC-645

AC-645 can also be applied on top of trucks for emission control during transport of materials such as contaminated soils or sewage sludge. Ammonia tests performed on trucks containing sewage sludge resulted in a drop of concentration levels from 170 ppm prior to foaming down to 6 ppm after coverage with AC-645.

- Minimizes worker exposure
- Maintains fence-line odor and VOC emission limits
- Works on lagoon and pond closures
- Can be applied to near vertical or liquid surfaces

FUGITIVE DUST

At hazardous waste sites, fugitive dust can present a health hazard. AC-645 can be applied on top of the dusty material to prevent any wind-borne emissions. There is no need to mobilize equipment to immediately cover with soil or tarps. The Pneumatic Foam Unit can be filled and placed at the site to be used at a moment's notice.

EMERGENCY SPILL CLEAN UP

In emergency spills, odor and VOC control is often difficult because of the terrain and accident conditions. AC-645 Long Duration Foam can be applied to any shaped object, as well as steep slopes, water, mud, snow and ice. It is non-flammable and non-reactive - difficult spill problems can be accommodated.

METHOD OF APPLICATION

AC-645 Long Duration Foam is supplied in either 450 pound (55 gal.) drums or by bulk load (approximately 46,000 pounds). Bulk shipments can be stored outside in a Rusmar Bulk Storage-Dilution System. The Bulk Storage and Dilution system is comprised of a 7000 gallon heated and stirred chemical storage tank and a microprocessor to accurately dilute and transfer the chemical. AC-645 is designed to be applied with a Rusmar Pneumatic Foam Unit. The Pneumatic Foam Units are available in a variety of sizes to accommodate a range of site conditions and application needs.



LONG DURATION FOAM AC-900 SERIES

GENERAL DESCRIPTION

The AC-900 Series Long Duration Foam products produce an impermeable, flexible membrane that seals a surface to prevent emissions. AC-900 Series foam products utilize foam as a distribution method for latex. After the foam has been applied, the air bubbles begin to collapse and the latex coagulates to form a continuous flexible membrane that adheres to the substrate. AC-900 Series products are designed for use with Rusmar Pneumatic Foam Units.

AC-900 Series foams are recognized by the Environmental Protection Agency and the U.S. Army Corps of Engineers as providing superior emission control for periods up to 6 months. AC-900 Series foams have been specified for use at Superfund and other hazardous waste sites across the United States and Canada.

FEATURES

- Adheres to vertical and irregular surfaces
- Completely controls odors & VOCs
- Prevents erosion
- Easy to use, no mixing necessary
- Available in black, red, green or brown
- Non-hazardous
- Controls dusting
- Repels water
- No temperature limitations
- More effective than tarps

APPLICATIONS

AC-900 Series foams are the technology of choice when conditions demand superior coverage for periods up to 6 months. Some of the more common uses are:

ODOR AND VOC CONTROL

As a medium for controlling odors and VOCs, AC-900 Series has proven to be very effective with diverse applications.

- Can be left in place or disposed of with soil - will not interfere with thermal or bioremediation process
- Extended odor & VOC control of open excavations or exposed trash
- Extended odor & VOC control of stockpiled soils or debris
- Special odor control problems, such as sewage sludge
- Baled trash cover - the membrane seals the surface completely



LONG DURATION FOAM AC-900 SERIES

FUGITIVE DUST

Exposed soil can often become a dust problem in windy locations, presenting a potential health hazard. Hazardous waste sites, receiving periodic shipments of dusty materials, can prevent windborne dust by immediately applying AC-900 Series foam.

- No need to mobilize equipment to immediately cover with soil or tarps. The Pneumatic Foam Unit can be filled and placed at the site to be used at a moment's notice.
- Extended dust control of stockpiled soils or debris

EROSION CONTROL

Graded areas can be covered with AC-900 Series Membrane reducing erosion damage caused by rain, melting snow or ice and wind.

- On outside slopes of the landfill – prevents trash from being exposed
- On landfill caps - prevents erosion before growth of new vegetation
- Stockpiles

SEALING HIGH PERCOLATION SOILS

Sand and other high percolation soils do not effectively repel rain water or melting snow and ice. Covering areas with AC-900 Series foam dramatically reduces soil permeability.

- Improved run-off from inside surfaces of the landfill
- Reduced leachate generation

WASTE TRANSPORTATION

Trucks or railcars transporting trash, odorous or dusty materials can be quickly covered with AC-900 Series foam to form a complete barrier between emissions and the atmosphere.

- No wind blown losses
- Produces a better visual appearance



LONG DURATION FOAM AC-900 SERIES

METHOD OF APPLICATION

AC-900 Series Long Duration Foam products are supplied in either 450 pound (55 gal.) drums or by bulk load (approximately 46,000 pounds). Bulk shipments can be stored outside in a Rusmar Bulk Storage-Dilution System. The Bulk Storage and Dilution system is comprised of a 7000 gallon heated and stirred chemical storage tank and a microprocessor to accurately transfer the chemical.

AC-900 Series products are designed to be applied with a Rusmar Pneumatic Foam Unit. The Pneumatic Foam Units are available in a variety of sizes to accommodate a range of site conditions and application needs.



REMEDIATION PRODUCT DATA SHEET

PNEUMATIC FOAM UNIT 1600/40



A completely self-contained and portable foam generating system designed to withstand the rugged demands and harsh elements found at remediation sites. Quick start-up time means that emission control is available when you need it. Recommended for medium to large size remediation projects, dredging operations and hazardous waste sites. Can be towed around site with a back-hoe or other large vehicle. Typically, foam is applied using a hand-line.

System includes air compressor, pump, hoses, nozzles, solution storage tank and proprietary foam generating technology. Unit has freeze protection for outdoor storage year-round.

FEATURES

- Simple to operate
- Durable, rugged construction
- No clean-up necessary
- Can be filled and placed aside until needed

SPECIFICATIONS

Solution Storage Tank.....	1600 Gallons
Coverage Rate.....	430 Sq. Ft./Min. @3" depth
Coverage Area.....	18,000 - 22,000 Sq. Ft.
Size.....	24' L x 8' W x 8'6" H
Weight.....	17,000 Pounds
Hose.....	200 Feet of 1-1/2" Diameter
Products.....	All Long Duration and Soil Equivalent Foam Products
Freeze Protection System.....	120V or 230V, 30 amp, single phase



REMEDIATION PRODUCT DATA SHEET

PNEUMATIC FOAM UNIT 400/25



A completely self-contained and portable foam generating system designed to withstand the rugged demands and harsh elements found at remediation sites. Quick start-up time means that emission control is available when you need it. Recommended for small to medium size remediation projects, dredging operations and hazardous waste sites. Can be towed around site with a pick-up truck. Foam is applied using a hand-line.

System includes air compressor, pump, hoses, nozzles, solution storage tank and proprietary foam generating technology. Unit has freeze protection for outdoor storage year-round.

FEATURES

- Simple to operate
- Durable, rugged construction
- No clean-up necessary
- Can be filled and placed aside until needed

SPECIFICATIONS

Solution Storage Tank..... 400 Gallons
Coverage Rate.....270 Sq. Ft./Min. @3" depth
Coverage Area per fill.....2,000 - 6,000 Sq. Ft.
Size.....16'8" L x 8'6" W x 7'8" H
Dry Weight.....6,880 Pounds
Hose..... 200 Feet of 1-1/2" Diameter
Products.....All Long Duration and Soil Equivalent Foam Products
Freeze Protection System.....120V or 230V, 30 amp, single phase

Appendix C of CERP
Noise Monitoring Plan



Environment

Prepared for:
Central Hudson
Gas and Electric Corporation
Poughkeepsie, New York

Prepared by:
AECOM
New York, New York
February 2018

Noise Monitoring Plan

**Former North Water Street Manufactured Gas Plant Site
Poughkeepsie, New York
Site ID No. C314070**

Contents

1.0 Introduction.....	1-1
1.1 Noise Basics	1-1
1.1.1 A-Weighting (dBA)	1-1
1.1.2 Equivalent Sound Level (Leq)	1-2
1.1.3 Maximum Sound Level (Lmax)	1-2
1.1.4 Statistical Descriptors	1-2
1.2 Noise from Typical Construction Equipment and Operations	1-2
1.3 Receptors	1-3
2.0 Noise Monitoring	2-1
2.1 Noise Monitoring	2-1
2.1.1 Pre-construction Noise Survey	2-2
2.1.2 Construction Period Noise Monitoring	2-2
3.0 Noise Thresholds	3-1
3.1 Noise Standards	3-1
3.1.1 Local City Codes	3-1
3.1.2 New York State	3-1
3.2 Noise Threshold Limits	3-1
3.3 Anticipated Noise Levels	3-2
4.0 Exceedance and Mitigation	4-1
4.1 Noise Mitigation	4-2
4.1.1 Tier 1- Mitigation Measures for General Site Construction	4-2
4.1.2 Tier 2- Mitigation Measures for Site-Specific Construction Activities.....	4-3
4.1.3 Tier 3- Focused Response Measures	4-3
4.2 Mitigation Protocol	4-4
5.0 References	5-1

List of Appendices

Appendix A Typical Construction Equipment Noise Levels

Appendix B Construction Noise Mitigation Measures

List of Tables

Table 1-1	Typical Equipment 50 Feet Emission Reference Levels and Usage Factors
Table 3-1	Human Reaction to Increase in Sound Pressure Level
Table 3-2	Preliminary Noise Threshold Levels
Table 4-1	Required Action for "Warning Action Limit" or "Stop Work Action Limit"

List of Figures

Figure 1	Typical Sound Levels of Noise Sources and Expected Reactions
Figure 2	Approximate Noise Monitoring Locations

List of Acronyms

ANSI	American National Standards Institute
CEQR	City Environmental Quality Review Technical Manual
CHGE	Central Hudson Gas & Electric Corporation
dB	Decibels
DNAPL	Dense Non Aqueous Phase Liquid
EPA	Environmental Protection Agency
Leq	Energy equivalent or energy average sound level
Lmax	“Slow response” maximum sound level
MGP	Manufactured Gas Plant
NYSDEC	New York State Department of Environmental Conservation
Site	Former North Water Street MGP site, Poughkeepsie, Dutchess County, NY
SPL	Sound Pressure Level

1.0 Introduction

This Noise Monitoring Plan has been prepared by AECOM USA, Inc. (AECOM), on behalf of Central Hudson Gas & Electric Corporation (CHGE), to provide a summary of noise monitoring activities that will be implemented to monitor potential noise impacts resulting from the remedial construction activities at the former North Water Street Manufactured Gas Plant (MGP) site (Site) located in Poughkeepsie, Dutchess County, New York. The Noise Monitoring Plan identifies the relevant criteria, the proposed monitoring locations, and the mitigation procedures for responding to observed exceedances of the noise thresholds. The remedial activities will be implemented according to the New York State Department of Environmental Conservation (NYSDEC) Decision Document (March 2016) to address the residuals left behind from the former MGP operations.

The Noise Monitoring Plan is an “evergreen document” and is intended to be a framework within which noise levels from the excavation, dredging, and sheet piling activities are documented and recorded. Any changes to the proposed remedial construction activities and the proposed construction phases will be updated in a revised Noise Monitoring Plan as necessary. Evaluations of the noise monitoring program and requirements by the Engineer should be completed periodically to determine if more or less monitoring is required.

This Noise Monitoring Plan does not preclude the use of other mitigation technologies or techniques designated in other design documents.

1.1 Noise Basics

Noise can be defined as unwanted sound. Sound is generated by pressure waves in air. Sound pressure level (SPL) is used to measure the intensity of sound, which is described in terms of decibels. The decibel (dB) is a logarithmic unit that expresses the ratio of the sound pressure level being measured to a standard reference level. Sound pressure waves may be of various frequencies. The human ear responds only to a limited range of frequencies. When measuring noise levels, frequencies to which the human ear does not respond must be filtered out. The procedure referred to as “A-scale” weighting best approximates the frequency response of the human ear. Sound levels measured on the A scale are designated by the term dBA.

A number of noise descriptors are used to characterize various aspects of noise that take into account the variability of noise levels over time. Common descriptors, criteria, and guidelines used to characterize noise are discussed below.

1.1.1 A-Weighting (dBA)

Noise measurements are most often taken using the "A-weighted" frequency response function. The A-weighted frequency or dBA scale simulates the response of the human ear to sound levels (particularly low-level sound) and has been given prominence as a means for estimating annoyance caused by noise; for estimating the magnitude of noise-induced hearing damage; for use in hearing conservation criteria; for speech interference measurements; and in procedures for estimating community reaction to (general broadband) noise (Clayton, 1978; Cheremisinoff, 1977). Figure 1 gives typical A-weighted sound levels for various noise sources and the typical reactions to these

levels (Advanced Engineering Acoustics, 2010). All sound levels referred to in this document are A-weighted, slow response, sound pressure levels.

The two acoustical metrics most frequently used to provide a single number sound level for time-varying sounds over a given time period are the energy equivalent or energy average sound level (L_{eq}) and the “slow response” maximum sound level (L_{max}).

1.1.2 Equivalent Sound Level (L_{eq})

The equivalent sound level (L_{eq}) is the value of a steady-state sound which has the same A-weighted sound energy as that contained in the time-varying sound. The L_{eq} is a single sound level value for a desired duration which includes all of the time-varying sound energy during the measurement period. The U.S. Environmental Protection Agency (EPA) has selected the L_{eq} as the best environmental noise descriptor primarily because it correlates reasonably well with the effects of noise on people, even for wide variations of environmental sound levels and different time exposure patterns.

The long-term A-weighted energy average sound level, called the 24-hour equivalent sound level, $L_{eq}(24h)$, is the logarithmic average of the individual 24 hourly equivalent sound levels, $L_{eq}(hi)$. Since it has been found that noise is more disturbing in the evening and nighttime when the ambient noise is generally quieter, modifications to the 24-hour L_{eq} have been adopted. The Day-Night sound level (DNL or L_{dn}) is a 24-hour energy average noise level based on the daytime and nighttime hourly average $L_{eq}(h)$ noise levels, with a 10 dB penalty added to each hourly nighttime average noise level.

1.1.3 Maximum Sound Level (L_{max})

The L_{max} is the maximum measured sound level at any instant in time.

1.1.4 Statistical Descriptors

Statistical sound level descriptors such as L10, L50, and L90 are used to represent noise levels that are exceeded, 10, 50, and 90 percent of the time, respectively. L50, the SPL exceeded 50 percent of the time, provides an indication of the median sound level. L90 represents the residual level, or the background noise level, without intrusive noises. The L10 is the sound level that is exceeded 10 percent of the time for a specified monitoring period.

1.2 Noise from Typical Construction Equipment and Operations

The equivalent sound level (L_{eq}) as it relates to construction activity depends on several factors including machine power, the manner of operation and the amount of time the equipment is operated over a given time period. The following provides information on typical levels generated by various construction equipment and provides guidance on determining the noise from construction activities.

The most dominant source of noise for the majority of construction equipment is the engine exhaust. However, for some construction work, such as impact pile driving or pavement breaking, the noise produced by the work process is the dominant source. Similar construction activities can create different noise impacts, depending on the location of the construction site, the terrain, and other intervening features and the type of receptor populations in the vicinity of the construction site. Equipment backup alarm and truck bed slamming during deliveries are also known sources of noise during construction activities.

For most construction activities, different construction equipment operate in one of two modes, *stationary* and *mobile*. *Stationary* equipment are those that operate in one small area for one or more days at a time, with either a steady power cycle operation (e.g., pumps, generators, compressors, etc.) or a periodic impulsive operation (e.g., pile drivers, pavement breakers, etc.). *Mobile* equipment are those that frequently move around a much larger area of the construction site with power applied in a rapidly changing, non-steady fashion (e.g., bulldozers, loaders, etc.), or move to and from the construction site (e.g., haul trucks, material trucks, etc.). These variations in operating power and location add a great deal of complexity in characterizing the source noise level of a given piece of construction equipment. This complexity can be simplified by determining the equipment noise level at a 50-foot reference distance from the equipment operating at full power and adjusting its full power noise level according to the duty cycle or "usage factor" of the particular construction activity and project phase to determine the characteristic noise level of the operation during each phase.

The NYSDEC Program Policy "Assessing and Mitigating Noise Impacts" on Construction Noise Mitigation rule provides typical construction equipment noise reference levels measured in terms of L_{eq} at 50 feet distance for those with potential to be used during the construction.

Society of Automotive Engineers has developed standardized procedures for measuring reference noise levels for the certification of mobile and stationary construction equipment. For informational purposes, typical 50-foot reference noise levels from representative pieces of construction equipment are listed in Appendix A.

Construction activity noise is characterized by the combined duty cycle and resulting noise emission of each piece of equipment. The duty cycle is expressed in terms of the "usage factor" of the equipment, which is the percentage of time during the work period that the equipment is operating under load or at near full power. Typical equipment "usage factor" is shown in Table 1-1. Final noise level limits will be decided upon discussions with the City of Poughkeepsie.

In addition to the minute-by-minute variations in noise producing activities, construction projects are carried out in several different phases. Each phase has a different equipment mix depending on the work to be accomplished. Some have more continuous noise, while others may have more impact type noise. Construction phase equipment usage factors, combined with receptor distances and equipment noise emissions, can be used in estimating future project noise (See Section 3).

1.3 Receptors

A background noise survey will be conducted prior to mobilization of construction equipment. If an access agreement is already in place, the noise monitoring points will be placed as close as practicable to the receptor property. For properties where an access agreement has not been negotiated, the noise monitoring points will be placed near the property line of the potentially affected property. The following properties are located near the site and will be monitored for any noise impacts resulting from construction activities:

- Pedestrian bridge (Walkway Over the Hudson) above the site and park south of the site
- Residences across the Hudson River west of the site
- Businesses/museum to the south of the project site
- Construction activity in adjacent property directly north of the project site

Table 1-1 Typical Equipment 50 Feet Emission Reference Levels and Usage Factors

Equipment	Noise Level (L_{max}) dBA at 50 feet	Usage Factor (%)
Auger Drill Rig	85	20
Backhoe	80	40
Chain Saw	85	20
Clam Shovel (dropping) Trucks	93	20
Air Compressor	80	40
Concrete Saw	90	20
Crane	85	16
Dozer	85	40
Dump Truck	84	40
Front End Loader	80	40
Excavator	85	40
Generator	82	50
Impact Pile Driver	95	20
Jackhammer	85	20
Hoe Ram	90	20
Pump	77	50
Rock Drill	85	20
Roller	85	20
Slurry Trenching Machine	82	50
Soil Mix Drill Rig	80	50
Tractor	84	40
Vibratory Pile Driver	95	20

2.0 Noise Monitoring

The remedial activities that may require noise monitoring include site preparation work, pre-trenching, sheet pile installation, land-site excavation of limited areas, dredging and capping of impacted sediments, and restoration.

Any project related noise monitoring performed at the site will be done so in coordination with the remediation Contractor. The remediation Contractor shall provide the proposed construction sequence to the Construction Manager a minimum of 2 weeks prior to mobilization to allow mobilization for noise monitoring. The remediation Contractor shall provide a minimum of 48-hour notice to the Construction Manager before they mobilize. The Contractor shall provide a minimum of 24-hour notice to the Construction Manager before the Contractor begins any demolition or hammering activities. The Construction Manager shall coordinate placement of the noise monitoring equipment with the remediation Contractor.

Monitoring equipment proposed for the construction noise measurements shall be in compliance with or exceed the criteria for a Type 1 or Type 2 instrument in accordance with the American National Standards Institute (ANSI), S1.4. The sound level meters to be used are capable of collecting a wide range of measurements, taking several measurements simultaneously and automatically storing data at the end of a pre-set time period.

2.1 Noise Monitoring

The planned remedial construction activities will be performed so as to limit the potential for adverse impacts due to noise. The installation of sheet piles and demolition activities might increase noise levels above background conditions. Other planned remediation activities are not expected to produce noise above the background conditions.

Noise monitoring will be conducted at the site entrance on Dutchess Avenue and by the elevator for the Walkway Over the Hudson Bridge. The number and locations of monitoring points may be adjusted as the field work progresses to obtain the most representative data in proximity to sensitive receptors. Monitors may be re-located based on site activity, field logistics, and access to adjacent properties.

At each location, the noise levels from the construction equipment and truck passbys will be measured during each construction phases. The following construction phases are currently proposed as part of the remedial activity:

- Equipment mobilization;
- Upland excavation and disposal;
- Installation of subsurface barrier/bulkhead wall; and
- In-River work including sediment dredging and cap placement.

2.1.1 Pre-construction Noise Survey

Given the construction setting around the project site, it is anticipated that the ambient L_{eq} and L_{max} levels are relatively high. In order to establish and identify the construction-generated noise component in ambient noise during construction period, it is important to conduct a pre-construction noise survey at selected monitoring sites through which appropriate warning thresholds can be reasonably established during the construction period monitoring.

A pre-construction noise survey will be undertaken prior to the initiation of any activity at the project site. The objective of the noise survey will be to establish baseline ambient noise condition caused by vehicular traffic (buses, cars, trucks, and other noise sources) near the sensitive properties selected surrounding the project site. These noise levels will be compared to noise induced during construction and may be used to revise noise warning threshold.

2.1.2 Construction Period Noise Monitoring

Noise monitoring will be conducted based on ANSI standard established requirement including instrumentation, calibration, and ambient weather condition including wind, temperature range, rain condition, etc. Specific monitoring procedures will follow detail steps described in the NYSDEC Program Policy "*Assessing and Mitigating Noise Impacts.*"

During monitoring, the following procedures will be followed:

- The sound level meter shall be calibrated using an acoustic calibrator, according to the manufacturer's specifications, just before each measurement.
- Noise measurements will be performed using the A-weighting network and the "slow" response of the sound level meter but "fast" response can be used for impulsive noise if applicable.
- The microphone will be fitted with a windscreen.
- The noise monitoring will be measured at approximately four to five feet above the ground surface.
- Monitoring will be performed at least three to four feet away from the nearest acoustically-reflective surface (i.e., fences, buildings, body of the person performing the measurements).
- Noise level measurements will be continuously taken during the daytime during sheet pile installation and excavation activities. Need for continuous noise monitoring will be evaluated during the sediment dredging and capping activities.
- If, in the estimation of the person performing the measurements, non-project related noise sources contribute significantly to the measured noise level, additional measurements (with the same non-project noise source contributions) shall be repeated when project construction is inactive to determine the non-project ambient background noise level.
- L_{eq} and L_{max} noise measurements will be computed.
- Noise measurements will be performed during the construction activity that has the greatest noise potential.
- Noise measurement data will be stored electronically and summarized with notice upon request (i.e., tables, plotted graphically, etc.) and will also be compared with the baseline survey data.
- Construction activities observed during noise monitoring will be noted.

Noise monitoring equipment will be operated, maintained, and calibrated in accordance with the manufacturer's instructions and the established quality assurance procedures. Noise monitoring equipment will be checked daily for proper operation. Field validation logs will be maintained on-site.

3.0 Noise Thresholds

3.1 Noise Standards

3.1.1 Local City Codes

Construction noise is regulated by the local City Code and by the EPA noise emission standards for construction equipment.

Construction noise is usually temporary and of relatively short duration. The local requirements mandate that certain classifications of construction equipment and motor vehicles meet specified noise emissions standards. As per the City of Poughkeepsie Building Code e360, Chapter 13 ½, operation of construction equipment will be prohibited between 9 PM and 6:30 AM, unless during an emergency and then only with a permit of the Building Inspector.

3.1.2 New York State

The NYSDEC has published a policy and guidance document titled *Assessing and Mitigating Noise Impacts* (NYSDEC, 2000). This document provides guidance on when noise due to projects has the potential for adverse impacts and requires review and possible mitigation in the absence of local regulations. The NYSDEC guidance indicates that local noise ordinances or regulations are not superseded by the NYSDEC guidance. The guidance contains a table identifying expected human reaction to various increases in sound pressure levels. The contents of that table are presented as Table 3-1 below. The New York State guidance indicates that a noise increase of 10 dBA at a residential property boundary deserves consideration of avoidance and mitigation measures in most cases. These guidelines are intended for permanent noise sources and do not apply to temporary noise sources such as construction work; however, these guidelines can be used as reference for the perception of noise.

Table 3-1 Human Reaction to Increases in Sound Pressure Level

Increase in Sound Pressure (dBA)	Human Reaction
Under 5	Unnoticed to Tolerable
5 – 10	Intrusive
10 – 15	Very Noticeable
15 – 20	Objectionable
Over 20	Very Objectionable to Intolerable

Source: *New York State Department of Environmental Conservation Program Policy: Assessing and Mitigating Noise Impacts, 2001.*

3.2 Noise Threshold Limits

Three “action” noise threshold levels will be used to evaluate the potential for noise level exceedance near the sensitive receptors (Table 3-2). Monitoring to assess the threshold noise levels will be the

L_{eq} , measured/evaluated outdoors between sensitive receptors and the construction activity at the project site using a 10 minute average recording. Placement of monitors near sensitive receptors will provide data on noise levels in these areas. Measured sound levels based on a monitored 10-minute average will be compared to the action levels to be finalized after the pre-construction noise survey is completed. The Stop Work Action Level will be anticipated to follow the Local Law-established 85 dBA threshold. However, whether this level is reasonable will be further evaluated after the pre-construction noise survey is completed. At the same time, if any impact equipment operation (e.g., sheet pile, hoe ram) is required, impulsive impact will be monitored as well to determine whether the city noise code-defined threshold is exceeded.

Table 3-2 Preliminary Noise Threshold Levels

Monitoring Action Level	Warning Action Level	Stop Work Action Level
80	85	90

3.3 Anticipated Noise Levels

For reference purposes, a quantitative assessment of the noise levels from the project site construction activities may be completed. The recommended procedure for estimating noise levels from construction activities is as follows:

Calculate each phase's L_{max} according to the following method:

$$L_{max} [\text{equipment type}] = ML - 20 \log_{10} (D/50)$$

Where:

ML = Typical single equipment maximum noise level (L_{max}) at 50 feet, in dBA.

D = Distance from the equipment to the noise-sensitive location, in feet.

Repeat the above calculation for each item of potentially noisy equipment. Then, select the noisiest individual pieces of equipment that operate in their loudest mode at the very same time and combine them logarithmically to estimate the overall maximum construction noise level (L_{max}) at the noise-sensitive location(s) for each project phase, as follows:

$$L_{max} [\text{overall project at receptor}] = 10 \log_{10} (\sum 10^{(L_{max} [\text{equipment type}] / 10)})$$

Calculate each phase's one-hour L_{eq} according to the method recommended by the U.S. Federal Highway Administration (U.S. Department of Transportation, 1977), as follows:

First, the construction phase's one-hour L_{eq} is to be calculated at the sensitive receptor location for each item of potentially noisy equipment using the following equation:

$$L_{eq}(h) [\text{equipment type}] = ML - 20 \log_{10} (D/50) + 10 \log_{10} (N \times HP/100)$$

Where:

ML = Typical single equipment maximum noise level (L_{max}) at 50 feet, in dBA.

- D = Shortest distance (feet) from the equipment type to the nearest noise-sensitive location, or if a more sensitive receptor is further away, to the noise-sensitive receptor with the greatest impact.
- N = Maximum number of the same equipment type operating hourly on the project during the construction phase.
- HP = "Hourly percentage," expressed as the greatest nominal percent of time that the equipment is operated under load at the project site. This factor is based on EPA values or is estimated based on past experience with similar projects. Thus, the effective usage factor is (EUF) = N x HP/100.

Repeat the above calculations for each item of potentially noisy equipment. Then, the individual contributions of every item of equipment are to be combined logarithmically to obtain the overall construction hourly L_{eq} at the noise-sensitive location(s) for each project phase, as follows:

$$L_{eq}(h) \text{ [overall project at receptor]} = 10 \log_{10} \left(\sum 10^{(\text{one-hour } L_{eq} \text{ [equipment type]} / 10)} \right)$$

The calculated L_{max} and $L_{eq}(h)$ levels can then be compared with the construction noise threshold criteria. Where it is estimated that the criteria would be exceeded, noise mitigation planning can be undertaken.

4.0 Exceedance and Mitigation

Notwithstanding the specific noise levels specified herein, noise mitigation measures listed below will be utilized to minimize, to the greatest extent feasible, the noise levels near the project site:

- Develop and implement a noise monitoring program in order to quantify noise levels at nearby sensitive receptors during construction (this document);
- Inform people living and working in the vicinity about construction method, possible effects, quality control measures, precautions to be used, and channels of communication available to them;
- Route traffic and heavy equipment to avoid impacts to sensitive receptors;
- Operate earth-moving equipment on the site as far away from noise-sensitive sites as possible;
- Select demolition methods not involving impact, where possible;
- Minimize the use of impact devices, such as jackhammers, pavement breakers, and hoe rams. Where possible, use concrete crushers or pavement saws rather than hoe rams for tasks such as concrete structure removal;
- Provide impact noise producing equipment, i.e. jackhammers and pavement breaker(s), with noise attenuating shields, shrouds, portable barriers, or enclosures to reduce operating noise;
- Avoid, to the extent possible, use of vibratory rollers and packers near sensitive areas;
- Schedule work to limit weekend and nighttime work;
- Utilize OSHA-compliant quieter-type manually adjustable backup alarms set to their low level;
- Utilize shields, impervious fences, or other physical barriers to inhibit transmission of noise;
- Utilize sound retardant housings or enclosures around noise producing equipment;
- Utilize effective intake and exhaust mufflers on internal combustion engines and compressors;
- Avoid, to the extent possible, the use of pneumatic or gasoline driven saws;
- Disarm all back-up alarms at 8:00 p.m. and do not reactivate until 7:00 a.m. on weekdays and 9:00 a.m. on weekends and local holidays. Signal persons and strobe lights must be used during periods when the back-up alarms are disarmed;
- Conduct loading, unloading, and hauling operations so that noise is kept to a minimum;
- Route construction equipment and other vehicles carrying spoil, concrete, or other materials over streets and routes that will cause the least disturbance to residents in the vicinity of the activity;
- Maximize physical separation, as far as practicable, between noise generators and noise receptors. Separation includes following measures:

- Provide enclosures for stationary items of equipment and noise barriers around particularly noisy areas at the project site; and
- Locate stationary equipment to minimize noise impacts on community.
- Minimize the duration of any high noise activities.

The following procedures are recommended if a measured level exceeds the damage thresholds.

4.1 Noise Mitigation

The mitigation approaches selected for use at the site consist of a combination of methods which will be implemented on a tiered approach. Three primary tiers will be implemented, as necessary, to mitigate noise associated with construction activities. A description of these measures, including applicability and implementability, is presented below and detailed in Appendix B.

4.1.1 Tier 1- Mitigation Measures for General Site Construction

Initial (Tier 1) mitigation measures will be implemented from the start of construction activities to address site-related construction noise levels. Tier 1 includes general mitigation measures for construction operations as listed below.

Noise mitigation measures for general construction, will include, but not be limited to:

- a. *The Contractor will self-certify in its construction noise mitigation plan that all construction tools and equipment have been maintained so that they operate at normal manufacturer's operating specifications, including at peak loading.*
- b. *All construction equipment being operated on site must be equipped with the appropriate manufacturer's noise reduction device.*
- c. *The Contractor shall mitigate noise from construction devices with internal combustion engines by ensuring that the engine's housing doors are kept closed and by using noise-insulating material mounted on the engine housing that does not interfere with the manufacturer's guidelines for engine operation or exhaust.*
- d. *Portable compressors, generators, pumps, and other such devices shall be covered with noise-insulating fabric to the maximum extent possible that does not interfere with the manufacturer's guidelines for engine operation or exhaust.*
- e. *Vehicle engine idling on site shall be prevented.*
- f. *Quieter back-up alarms shall be used in pre-2008 model year vehicles when practicable for the job site.*
- g. *The Contractor shall create and utilize a noise mitigation training program, which shall be implemented for all field-worker supervisory personnel including sub-Contractor supervisors.*
- h. *Construction activities may take place during the hours of permitted by the local rules and regulations.*

Most modern construction equipment is equipped with engine noise control devices (e.g., exhaust mufflers and acoustic casing enclosures) in accordance with Federal and State regulations. In addition to proper maintenance and operation of construction machinery, several means of controlling construction noise impacts will be employed as needed, and as may be practical, including:

- Operate earthmoving equipment on the project site as far away from noise-sensitive receptors as possible
- Avoid nighttime activity - operate equipment during daylight hours to limit any potential disturbance during the nighttime (sleep interference) periods, to the extent possible, in accordance with the local Noise Ordinance

4.1.2 Tier 2- Mitigation Measures for Site-Specific Construction Activities

Tier 2 mitigation measures include modifications to standard construction operation practices based on specific work activities to be conducted at the project site. Tier 2 mitigation measures include:

4.1.2.1 Construction Activities

The first consideration in the plan is to enforce an operational schedule for running construction equipment to make sure the noise from construction activities would occur in fewer noise-sensitive hours, particularly those during the morning.

4.1.3 Tier 3- Focused Response Measures

Tier 3 mitigation includes the identification of focused measures to address localized community feedback on a case-by-case basis. The objective of this approach is to address the concerns of individual community members with mitigation measures specific to their concern and/or circumstance. Tier 3 Measures are intended to be flexible in their implementation and will require direct discussions with individual community members. Some examples of potential Tier 3 Measures include:

4.1.3.1 Focused Inspections/Monitoring

Supplemental monitoring may be conducted immediately adjacent to the receptor properties as well as other properties based on community feedback and/or comparison to prescribed action levels.

4.1.3.2 Interior/Exterior Treatments

Treatments may include the placement of flexible coverings or acoustic materials on interior/exterior openings, windows and/or portions of the walls of businesses or residential dwellings in close proximity to construction activities. Treatment options will likely require additional property access and the cooperation of the affected building owners and/or residents.

4.1.3.3 Temporary Sound Barriers

Small-scale moveable and/or fixed barriers can be erected at locations along the project site perimeter. These barriers, which may be located on public rights-of-way, would be relatively low-profile and consist of sound attenuating material affixed to stationary or moveable platforms or stands. The exact construction and location of these barriers will be dependent on the presence of the aboveground obstructions (and overhead utilities), the existence of viable access points, the nature of the building or use in question, and the results of any focused monitoring.

Appendix B contains a detailed list of possible mitigation measures that can be employed.

4.2 Mitigation Protocol

Detailed review and interpretation of all noise data will be made in order to determine whether construction activities have resulted in an action limit.

In the event that a “Warning Action Level” is reached:

- The Contractor must meet with the Project Team to discuss the need for mitigation actions;
- The Engineer will develop the Tier 2 Mitigation Protocol and prepare a plan of action for the activity or activities responsible for the exceedance;
- If directed by the Engineer or the Construction Manager, the Contractor must implement the plan of action within 24 hours of submittal of the plan of action so that the “Stop Work Action Level” is not reached; and
- The monitoring frequency of the affected instrument will be increased and additional instruments installed if necessary.

In the event that a “Stop Work Action Level” is reached:

- The Contractor must meet with the Project Team to discuss the need for mitigation actions;
- The Engineer will develop the Tier 3 Mitigation Protocol and prepare a plan of action for the activity or activities responsible for the exceedance;
- If directed by the Engineer or the Construction Manager, the Contractor must implement the plan of action within 12 hours of submittal of the plan of action so that the “Stop Work Action Level” is not exceeded further; and
- The Contractor must install additional instrumentation if necessary.

The definition of the required action that must be taken should any instrument achieve an action limit is defined in Table 4-1 below:

Table 4-1 Required Action for “Warning Action Limit” or “Stop Work Action Limit”

Action Limit	Required Action
Warning Action Level	The value of the noise instrumentation reading at which the Engineer and Contractor jointly assess the necessity of either or all of the following: <ul style="list-style-type: none"> • Evaluate the activity responsible for the exceedance • Install acoustic insulation if necessary • Alter the method of excavation or construction • Alter the rate of excavation or construction • Alter the sequence of excavation or construction • Change excavation/dredge or construction machinery • Increase frequency of monitoring of affected instrument

Stop Work Action Limit	<p>The value of the noise instrumentation reading at which the Engineer and Contractor jointly assess the necessity of either or all of the following:</p> <ul style="list-style-type: none">• Cease excavation/dredging or construction operations• Make site and affected properties secure <p>Take necessary predetermined measures to mitigate movements and assure the safety of the public and the Work. The Stop Work Action Level for each instrument represents the absolute maximum noise level.</p>
------------------------	---

Work procedures will be evaluated and modified to prevent further exceedance of the monitoring criteria. All work activities will only proceed at the discretion of the Engineer and after the source of the exceedance has been determined and corrected.

5.0 References

Advanced Engineering Acoustics, 2010. "*Construction Noise Threshold Criteria and Control Plan*," Adapted 2005, Amended 2010, County of Ventura, Simi Valley, CA. July 2010.

Cheremisinoff, P.N. and P.P. Cheremisinoff. 1977. "*Industrial Noise Control Handbook*." Ann Arbor Science Publishers, Inc. 1977.

Clayton, G.D. and F.E. Clayton, 1978. "*Volume I: General Principles - Patty's Industrial Hygiene and Toxicology*," Third Revised Edition. John Wiley & Sons, Inc. 1978.

Federal Transit Administration, 2006. "*Transit Noise and Vibration Impact Assessment*," FTA-VA-90-1003-06, U.S. Department of Transportation, Washington, DC. May 2006.

Department of Environmental Conservation (NYSDEC). 2001. "*Assessing and Mitigating Noise Impacts - PROGRAM POLICY*", Department ID:DEP-00-1. October 6, 2000 Revised: February 2, 2001.

U.S. Environmental Protection Agency (EPA), 1971. "*Noise from Construction Equipment. NTID 300.1*." 1971.

U.S. EPA, 1974. "*Information on Levels of Environmental Noise Requisite to Protect Public Health and Welfare with an Adequate Margin of Safety*." EPA 550/9-74-004. March 1994.

U.S. EPA, 1978. "*Protective Noise Levels*," Condensed Version of EPA Levels Document, EPA 550/9-79-100. November 1978.

Figures

Figure 1 Typical Sound Levels of Noise Sources and Expected Reactions

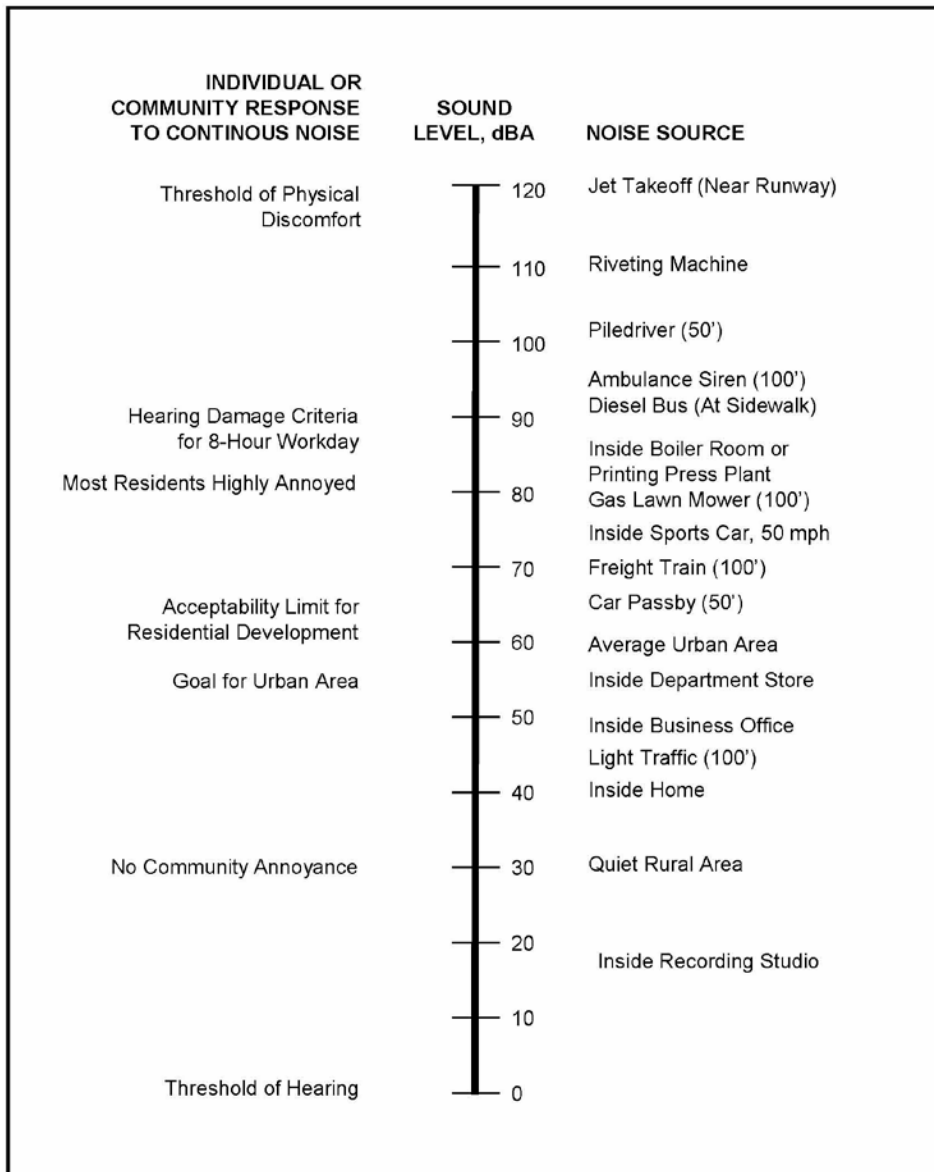

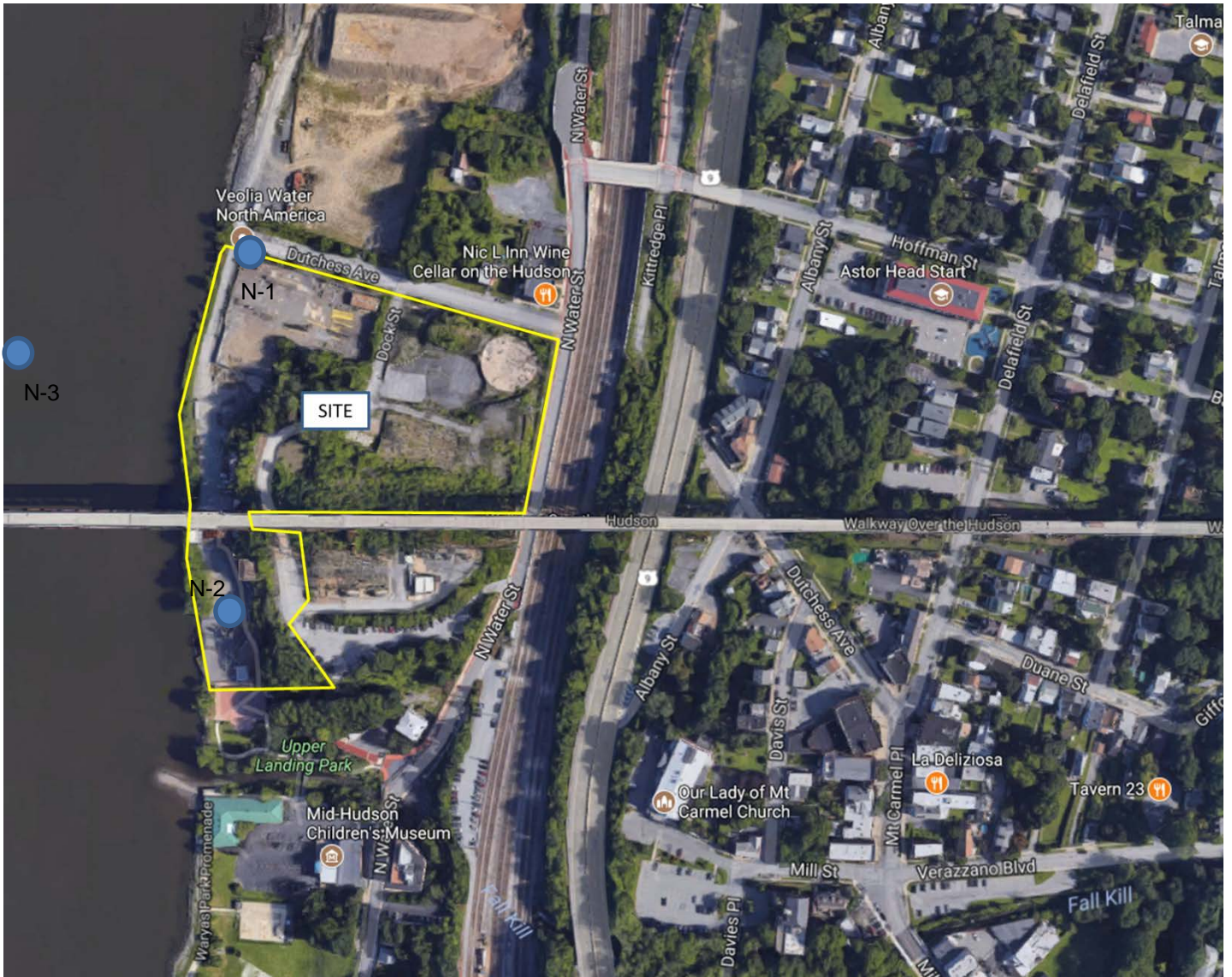

Figure 2 Approximate Noise Monitoring Locations

Appendices

Appendix A

Typical Construction Equipment Noise Levels

Appendix A

Typical Equipment Noise, Construction Phases and Use Factors

Figure A-1. Typical Construction Equipment Noise

Equipment Type Noise Source	Dominant Noise Components ¹	50-Foot Noise Level (L _{eq}) dBA ^{2,3}	Noise Level Range (L _p) dBA ^{2,3}	50-Foot Maximum Noise Level (L _{max}) dBA ^{2,3}
Air Compressor (portable) ⁴	E, C, H, I	81	76-89	89
Air Compressor (stationary)	E, C, H, I	82	76-89	89
Auger, Drilled Shaft Rig	E, C, F, I, W	82	76-89	89
Backhoe	E, C, F, I, H, W	85	81-90	90
Bar Bender	E, P, W	82	78-88	85
Chain Saw	E, W, C	85	72-88	88
Compactor	E, C, F, I, W	82	81-85	85
Concrete Batch Plant	W, E, C	92	80-96	96
Concrete Mixer (small trailer)	W, E, C	67	65-68	68
Concrete Mixer Truck	E, C, F, W, T	85	69-89	89
Concrete Pump Trailer	E, C, H	82	74-84	84
Concrete Vibrator	W, E, C	76	68-81	81
Crane, Derrick	E, C, F, I, T	88	79-90	90
Crane, Mobile	E, C, F, I, T	83	80-85	85
Dozer (Bulldozer)	E, C, F, I, H	80	77-90	90
Excavator	E, C, F, I, H, W	87	83-92	92
Forklift	E, C, I, W	84	81-86	86
Front End Loader	E, C, F, I, H	79	77-90	90
Generator	E, C	78	71-87	87
Gradall	E, C, F, I, W	82	78-85	85
Grader	E, C, F, I, W	85	79-89	89
Grinder	W	80	75-82	82
Hydraulic Hammer	W, E, C, H	102	99-105	105
Impact Wrench	W, P	85	75-85	85
Jack Hammer	P, W, E, C	82	75-88	88
Paver	E, D, F, I	89	82-92	92
Pile Driver (Impact/ Sonic/ Hydraulic)	W, P, E	101 / 96 / 65	94-107 / 90-99 / 65	107 / 99 / 65
Pavement Breaker	W, E, P	82	75-85	85
Pneumatic Tool	P, W, E, C	85	78-88	88
Pump	E, C	76	68-80	80
Rock Drill	W, E, P	98	83-99	99
Roller	E, C, F, I, W	74	70-83	83
Sand Blaster	W, E, C, H, I	85	80-87	87
Saw, Electric	W	78	59-80	80
Scraper	E, C, F, I, W	88	82-91	91
Shovel	E, C, F, I, W	82	77-90	90
Tamper	W, E, C	86	85-88	88
Tractor	E, C, F, I, W	82	77-90	90
Trencher		83	81-85	85
Trucks (Under Load)	E, C, F, I, T	88	81-95	95
Water Truck	W, E, C, F, I, T	90	89-94	94
Other Equipment with Diesel	E, C, F, I	82	75-88	88

Note 1. Ranked noisy components. C=Casing, E=Exhaust, F=Fan, H=Hydraulics, I=Intake air, P=Pneumatic exhaust, T=Transmission, W=Work tool.

Note 2. Table based on EPA studies and measured data from various construction equipment and manufacturer's data.

Note 3. Equipment noise levels are at 50 feet from individual construction equipment and with no other noise contributors.

Note 4. Portable air compressor rated at 75 cfm or greater and operating at greater than 50 psi.

**Figure A-2
Typical Domestic Housing Construction Equipment and Use Factors**

Equipment Item	50-Foot Leq, dBA	Mitigated ¹ Leq, dBA	Highest Hourly Use Percentage per Construction Phase				
			Clear	Excavate	Base	Build	Finish
Air Compressor	81	75	--2	10	--	--	25
Backhoe	85	75	2	4	--	--	2
Concrete Mixer	85	75	--	--	4	8	16
Concrete Pump	82	75	--	--	--	--	--
Concrete Vibrator	76	75	--	--	--	--	--
Crane, Derrick	88	75	--	--	--	--	--
Crane, Mobile	83	75	--	--	--	10	4
Dozer	80	75	4	8	--	--	4
Generator	78	75	4	--	--	--	--
Grader	85	75	5	--	--	--	2
Jack Hammer	82	75	--	--	--	--	3
Loader	79	75	4	8	--	--	4
Paver	89	80	--	--	--	--	3
Pile Driver	101	95	--	--	--	--	--
Pneumatic Tool	85	80	--	--	4	10	4
Pump	76	75	--	4	7	--	--
Rock Drill	98	80	--	1	--	--	0.5
Roller	74	74	--	--	--	--	4
Saw, Electric	78	75	--	--	4 (2) 3	10 (2)	4 (2)
Scraper	88	80	5	--	--	--	1
Shovel	82	75	--	2	--	--	--
Truck	88	75	16	40	--	--	16

Note 1. Estimated level obtainable by quieter methods or equipment and implementing feasible noise controls.

Note 2. "--" indicates typically zero or very little use during construction phase.

Note 3: Numbers in parentheses are greatest multiple number of same items in use.

**Figure A-3
Typical Large Building and Institutional Construction Equipment and
Use Factors**

Construction Equipment	50-Foot Leq, dBA	Mitigated ¹ Leq, dBA	Highest Hourly Use Percentage per Construction Phase				
			Clear	Excavate	Base	Build	Finish
Air Compressor	81	75	--2	100 (2) 3	100 (2)	100 (2)	40 (2)
Backhoe	85	75	04	16	--	--	4
Concrete Mixer	85	75	--	--	40	40	16
Concrete Pump	82	75	--	--	40	8	8
Concrete Vibrator	76	75	--	--	40	10	4
Crane, Derrick	88	75	--	--	--	16	4
Crane, Mobile	83	75	--	--	--	16 (2)	4 (2)
Dozer	80	75	16	40	--	--	16
Generator	78	75	40 (2)	100 (2)	--	--	--
Grader	85	75	8	--	--	--	2
Jack Hammer	82	75	--	10	4	4	4
Loader	79	75	16	40	--	--	16
Paver	89	80	--	--	--	--	10
Pile Driver	101	95	--	--	4	--	--
Pneumatic Tool	85	80	--	--	4	16 (2)	4 (2)
Pump	76	75	--	100 (2)	100 (2)	40	--
Rock Drill	98	80	--	4	--	--	0.5
Roller	74	74	--	--	--	--	--
Saw, Electric	78	75	--	--	4 (3)	100 (3)	--
Scraper	88	80	55	--	--	--	--
Shovel	82	75	--	40	--	--	--
Truck	88	75	16 (2)	40	--	--	16

Note 1. Estimated level obtainable by quieter methods or equipment and implementing feasible noise controls.

Note 2. "--" indicates typically zero or very little use during construction phase.

Note 3: Numbers in parentheses are greatest number of same items in use during any hour.

Figure A-4
Typical Commercial and Industrial Construction Equipment and Use Factors

Construction Equipment	50-Foot Leq, dBA	Mitigated ¹ Leq, dBA	Highest Hourly Use Percentage per Construction Phase				
			Clear	Excavate	Base	Build	Finish
Air Compressor	81	75	--2	100	40	40	40
Backhoe	85	75	4	16	--	--	4
Concrete Mixer	85	75	--	--	40	16	16
Concrete Pump	82	75	--	--	40	--	8
Concrete Vibrator	76	75	--	--	--	--	--
Crane, Derrick	88	75	--	--	--	4	2
Crane, Mobile	83	75	--	--	--	8	4
Dozer	80	75	4	16	--	--	4
Generator	78	75	40	40	--	--	--
Grader	85	75	5	--	--	--	2
Jack Hammer	82	75	--	10	4	4	4
Loader	79	75	16	16	--	--	4
Paver	89	80	--	--	--	--	12
Pile Driver	101	95	--	--	4	--	--
Pneumatic Tool	85	80	--	--	4	10 (3) 3	4 (3)
Pump	76	75	--	40	100 (2)	40	--
Rock Drill	98	80	--	4	--	--	5
Roller	74	74	--	--	--	--	10
Saw, Electric	78	75	--	--	4 (2)	10 (2)	--
Scraper	88	80	14	--	--	--	8
Shovel	82	75	--	20	--	--	6
Truck	88	75	16 (2)	16 (2)	--	--	16

Note 1. Estimated level obtainable by quieter methods or equipment and implementing feasible noise controls.

Note 2. "--" indicates typically zero or very little use during construction phase.

Note 3: Numbers in parentheses are greatest number of same items in use during any hour.

Figure A-5
Typical Public Works and Roadway Construction Equipment and Use Factors

Construction Equipment	50-Foot Leq, dBA	Mitigated ¹ Leq, dBA	Highest Hourly Use Percentage per Construction Phase				
			Clear	Excavate	Base	Build	Finish
Air Compressor	81	75	--2	100 (2) ³	40	40	40 (2)
Backhoe	85	75	4	40	--	--	16
Concrete Mixer	85	75	--	--	16 (2)	40 (2)	16 (2)
Concrete Pump	82	75	--	--	--	--	--
Concrete Vibrator	76	75	--	--	--	--	--
Crane, Derrick	88	75	--	10	4	4	--
Crane, Mobile	83	75	--	--	--	16	--
Dozer	80	75	4	40	--	--	16
Generator	78	75	100 (2)	40 (2)	40 (2)	40	40 (2)
Grader	85	75	8	--	--	20	8
Jack Hammer	82	75	--	--	--	4	10 (2)
Loader	79	75	4	40	--	--	16
Paver	89	80	--	--	--	--	--
Pile Driver	101	95	--	--	--	--	--
Pneumatic Tool	85	80	--	--	4 (2)	10	4
Pump	76	75	--	40 (2)	100 (2)	40 (2)	--
Rock Drill	98	80	--	4	--	--	--
Roller	74	74	--	--	100	--	--
Saw, Electric	78	75	--	--	4 (2)	--	--
Scraper	88	80	8		20	8	8
Shovel	82	75	4	40	4	--	4
Truck	88	75	16 (2)	16	40 (2)	--	16 (2)

Note 1. Estimated level obtainable by quieter methods or equipment and implementing feasible noise controls.

Note 2. "--" indicates typically zero or very little use during construction phase.

Note 3: Numbers in parentheses are greatest number of same items in use during any hour.

Appendix B

Construction Noise Mitigation Measures

Construction Noise Mitigation Measures

Construction noise mitigation may be achieved using various combinations of equipment source noise reduction, propagation path noise reduction and sensitive receptor noise reduction.

Equipment Source Noise Reduction Methods

Feasible and reasonable equipment noise mitigation measures may need to be implemented to meet the construction noise threshold criteria. Examples of equipment source noise reduction methods to reduce construction noise impacts at sensitive receptor locations are listed in this section. The implementation of one or more of these measures, along with those of the other sections, may be necessary to achieve compliance with the construction noise threshold criteria.

Equipment Noise Reduction:

1. Minimize the use of impact devices, such as jackhammers, pavement breakers, and hoe rams. Where possible, use concrete crushers or pavement saws rather than hoe rams for tasks such as concrete or asphalt demolition and removal.
2. Pneumatic impact tools and equipment used at the construction site shall have intake and exhaust mufflers recommended by the manufacturers thereof, to meet relevant noise limitations.
3. Provide impact noise producing equipment, i.e. jackhammers and pavement breaker(s), with noise attenuating shields, shrouds or portable barriers or enclosures, to reduce operating noise.
4. Line or cover hoppers, conveyor transfer points, storage bins, and chutes with sound-deadening material (e.g., apply wood or rubber liners to metal bin impact surfaces).
5. Provide upgraded mufflers, acoustical lining or acoustical paneling for other noisy equipment, including internal combustion engines.
6. Avoid blasting and impact-type pile driving.
7. Use alternative procedures of construction and select a combination of techniques that generate the least overall noise and vibration. Such alternative procedures could include the following:
 - a. Use electric welders powered by remote generators.
 - b. Mix concrete at non-sensitive off-site locations, instead of on-site.
 - c. Erect prefabricated structures instead of constructing buildings on-site.

8. Use construction equipment manufactured or modified to reduce noise and vibration emissions, such as:
 - a. Electric instead of diesel-powered equipment.
 - b. Hydraulic tools instead of pneumatic tools.
 - c. Electric saws instead of air- or gasoline-driven saws.
9. Turn off idling equipment when not in use for periods longer than 30 minutes.

Operations Noise Reduction Methods:

In no case shall the following mitigation measures alter the project's responsibility for compliance with applicable Federal, state, and local safety ordinances and regulations, as well as project-specific construction specifications.

1. Operate equipment so as to minimize banging, clattering, buzzing, and other annoying types of noises, especially near residential and other noise sensitive areas during the evening and nighttime hours.
2. To the extent feasible, configure the construction site in a manner that keeps noisier equipment and activities as far as possible from noise sensitive locations and nearby buildings.
3. All back-up alarms should be disarmed at 8:00 p.m. and not reactivated until 7:00 a.m. on weekdays and 9:00 a.m. on weekends and local holidays. Signal persons and strobe lights must be used during periods when the back-up alarms are disarmed.
4. Maximize physical separation, as far as practicable, between noise generators and noise receptors. Separation includes following measures:
 - a. Provide enclosures for stationary items of equipment and noise barriers around particularly noisy areas at the project site.
 - b. Locate stationary equipment to minimize noise and vibration impacts on community.
5. Minimize noise-intrusive impacts during most noise sensitive hours.
 - a. Plan noisier operations during times of highest ambient noise levels.
 - b. Keep noise levels relatively uniform; avoid excessive and impulse noises.
 - c. Turn off idling equipment.
 - d. Phase in start-up and shut-down of project site equipment.

6. Select truck routes for material delivery and spoils disposal so that noise from heavy-duty trucks will have a minimal impact on noise sensitive receptors. Proposed truck haul routes are to be submitted to the local government for approval.
 - a. Conduct truck loading, unloading, and hauling operations so noise and vibration are kept to a minimum.
 - b. Route construction equipment and vehicles carrying soil, concrete or other materials over streets and routes that will cause the least disturbance to residents in the vicinity of construction sites and haul roads.

A summary of equipment noise control methods is given in Figure 1. Incorporating the construction noise mitigation methods and techniques would reduce construction noise and vibration impacts.

Construction Noise Propagation Path Reduction Methods

Feasible and reasonable propagation path mitigation measures may need to be implemented to help meet the construction noise threshold criteria. Examples of propagation path noise reduction methods to reduce construction noise impacts at sensitive receptor locations are listed in this section. The implementation of one or more of these measures, along with those of the other sections, may be necessary to achieve compliance with the construction noise threshold criteria.

Construction Site Noise Barriers

Moveable noise barriers can be positioned and relocated along a construction corridor, while fixed noise barriers can be located at a fixed construction site.

Moveable Construction Noise Blankets

1. For lesser noise reduction, install moveable frame-mounted noise curtains, blankets or enclosures adjacent to or around noisy equipment where required to meet the project noise limits. Noise control shields shall be made of a durable, flexible composite material featuring a noise barrier layer bonded to a weather-protected, sound-absorptive material on the construction-activity side of the noise shield.
2. Provide readily removable and moveable noise shields so that they may be repositioned, as necessary, to provide noise abatement for non-stationary and stationary processes along a construction corridor as the construction process moves.
3. Installation and Maintenance:
 - a. Install noise blanket shields with sound-absorptive surfaces facing the noise source.
 - b. Maintain the moveable noise shields and repair damage that occurs, including, but not limited to, keeping noise shields clean and free from graffiti, and maintaining structural integrity. Promptly repair or replace gaps, holes, and weaknesses in the noise shields, and openings between, or under the noise shield blankets.

Moveable Construction Noise Barriers

1. For greater noise reduction, install moveable paneled noise shields, barriers or enclosures adjacent to or around noisy equipment where required to meet the project noise limits. Noise control shields shall be made of panels featuring a solid panel with a weather-protected, sound-absorptive material on the construction-activity side of the noise shield.
2. Provide readily removable and moveable noise shields so that they may be repositioned, as necessary, to provide noise abatement for non-stationary and stationary processes along a construction corridor as the construction process moves.
3. Installation and Maintenance:
 - a. Install paneled noise shields with sound-absorptive surfaces facing the noise source.
 - b. Maintain the moveable noise shields and repair damage that occurs, including, but not limited to, keeping noise shields clean and free from graffiti, and maintaining structural integrity. Promptly repair or replace gaps, holes, and weaknesses in the noise shields, and openings between, or under the noise shield panels.

Fixed Construction Noise Curtains

1. For lesser noise reduction, install frame-mounted sound noise control curtains or noise control blankets in locations adjacent to or around noisy equipment as required to meet the noise limits specified in this document and to shield the public from excessive construction noise. Noise control curtains shall be made of a durable, flexible composite material featuring a noise barrier layer bonded to a weather-protected, sound-absorptive material on one or both sides. The supporting structure shall be engineered and erected according to applicable codes.
2. Noise control curtains shall be installed, as necessary, to provide greater noise abatement for non-stationary and stationary processes.
3. Installation, Maintenance and Removal
 - a. Noise control curtains shall be installed without any gaps and with the sound absorptive side facing the construction activity area.
 - b. Maintain the noise control curtains and promptly repair any damage that may occur. Gaps, holes or weaknesses in the curtain, or openings between the curtain and the ground shall be promptly repaired.
 - c. The fixed noise control curtains and associated elements shall be completely removed and the site appropriately restored upon the conclusion of the construction activity.

Fixed Noise Control Barriers

1. For greater noise reduction, install solid noise control panels or enclosures in locations adjacent to or around noisy equipment as required to meet the noise threshold criteria specified in this document and to shield the public from excessive construction noise. Noise control panels shall be made of a solid, heavy noise barrier material with a weather-protected, sound-absorptive material on the construction-activity side of the barrier. The supporting structure shall be engineered and erected according to applicable codes.
2. Noise control panels shall be erected, as necessary, to provide greater noise abatement for non-stationary and stationary processes.
3. Installation, Maintenance, and Removal
 - a. Solid noise control panels shall be installed without any gaps and with the sound absorptive side facing the construction activity area.
 - b. Maintain the noise control panels and promptly repair any damage that may occur. Gaps, holes or weaknesses in the panels or openings between the panels and the ground shall be promptly repaired.
 - c. The fixed noise control panels and associated elements shall be completely removed and the site appropriately restored upon the conclusion of the construction activity.

Sensitive Receptor Construction Noise Reduction Methods

Feasible and reasonable receptor noise mitigation measures may be implemented to meet the construction noise threshold criteria. Examples of receptor noise reduction methods to reduce construction noise impacts at sensitive receptor locations are listed in this section. The implementation of one or more of these measures, along with those of the other sections, may be necessary to achieve compliance with the construction noise threshold criteria.

Receptor Building Interior Noise Control Measures

1. For noise reduction at fixed, mid-term construction sites, install removable secondary acoustic window inserts (i.e., Quiet Window, or equal) to existing windows in sensitive receptor buildings as required to meet the noise threshold criteria specified in this document.
2. For noise reduction at fixed, long-term construction sites, install permanent replacement acoustic windows with an STC rating 5 dB greater than the construction noise reduction needed. Where sliding doors are exposed to excessive construction noise, acoustic sliding patio doors may also need to be installed. Careful attention must be taken to seal the frame airtight to the existing structure.
3. Install properly fitted, tubular compression-type weather strip gasketing around the door frames (jamb and head) and install automatic drop thresholds and threshold plates to exposed swinging doors. Careful attention must be taken to seal the existing door frame airtight to the existing structure.

Moveable Exterior Receptor Noise Control Barriers

1. For construction along a construction corridor, install moveable paneled noise shields or barriers at noise sensitive receptor sites. Noise control shields shall be made of panels featuring a solid panel with a weather-protected, sound-absorptive material on the construction-activity side of the noise shield.
2. Provide readily removable and moveable noise shields so that they may be repositioned, as necessary, to provide greater noise abatement along a construction corridor as the construction process moves.
3. Installation and Maintenance:
 - a. Install paneled noise shields with sound-absorptive surfaces facing the noise source.
 - b. Maintain the moveable noise shields and repair damage that occurs, including, but not limited to, keeping noise shields clean and free from graffiti, and maintaining structural integrity. Promptly repair or replace gaps, holes, and weaknesses in the noise shields, and openings between, or under the noise shield panels.

Fixed Exterior Receptor Noise Control Barriers

1. For noise reduction at fixed construction sites, install solid noise control panels at sensitive receptor locations as required to meet the noise threshold criteria specified in this document and to shield the sensitive receptor from excessive construction noise. Noise control panels shall be made of a solid, heavy noise barrier material with a weather-protected, sound-absorptive material on the construction-activity side of the barrier. The supporting structure shall be engineered and erected according to applicable codes.
2. Noise control panels shall be erected, as necessary, to provide greater noise abatement for non-stationary and stationary processes at fixed construction sites.
3. Installation, Maintenance, and Removal
 - a. Solid noise control panels shall be installed without any gaps and with the sound absorptive side facing the construction activity area.
 - b. Maintain the noise control panels and promptly repair any damage that may occur. Gaps, holes or weaknesses in the panels or openings between the panels and the ground shall be promptly repaired.
 - c. The fixed noise control panels and associated elements shall be completely removed and the site appropriately restored upon the conclusion of the construction activity.

Appendix D of CERP

Vibration and Settlement Monitoring Plan



Environment

Prepared for:
Central Hudson
Gas and Electric Corporation
Poughkeepsie, New York

Prepared by:
AECOM
New York, New York
February 2018

Vibration and Settlement Monitoring Plan

**Former North Water Street Manufactured Gas Plant Site
Poughkeepsie, New York
Site ID No. C314070**

Contents

1.0 Introduction.....	1-1
1.1 Vibration Basics	1-1
1.2 Receptors.....	1-2
2.0 Vibration and Settlement Monitoring.....	2-1
2.1 Vibration Monitoring.....	2-1
2.1.1 Pre-construction Vibration Monitoring	2-1
2.1.2 Construction Period Vibration Monitoring	2-2
2.1.3 Construction Period Crack Monitoring	2-3
2.2 Settlement Monitoring.....	2-3
3.0 Vibration and Settlement Damage Thresholds.....	3-1
3.1 Vibration Damage Thresholds.....	3-1
3.2 Settlement Thresholds.....	3-4
4.0 Exceedance and Mitigation	4-1
4.1 Vibration and Settlement Mitigation	4-1
4.2 Crack Monitoring Exceedance	4-2
5.0 References	5-1

List of Appendices

Appendix A Expected Vibration Levels at Receptor Locations

List of Tables

Table 3-1	Construction Vibration Damage Criteria (in PPV)
Table 3-2	Preliminary Vibration Threshold Limits (in PPV)
Table 3-3	Vibration Source Levels for Construction Equipment
Table 3-4	Vibration Impacts Expected at Neighboring Receptors
Table 3-5	Settlement Limits
Table 4-1	Required Action for “Warning Action Limit” or “Stop Work Action Limit”

List of Figures

Figure 2-1	Approximate Vibration Monitoring Locations
------------	--

List of Acronyms

AASHTO	American Association of State Highway and Transportation Officials
bgs	below ground surface
CHGE	Central Hudson Gas & Electric Corporation
COIs	constituents of interest
in/s	inches per second
MGP	Manufactured Gas Plant
NYSDEC	New York State Department of Environmental Conservation
PPV	Peak Particle Velocity
VOCs	volatile organic compounds
USBM	United States Bureau of Mines
Site	Former North Water Street MGP site, Poughkeepsie, Dutchess County, New York

1.0 Introduction

This Vibration and Settlement Monitoring Plan has been prepared by AECOM Environment (AECOM), on behalf of Central Hudson Gas & Electric Corporation (CHGE), to provide a summary of vibration and settlement monitoring activities that will be implemented to monitor potential vibration and settlement impacts resulting from the remedial construction activities at the former North Water Street Manufactured Gas Plant (MGP) site (Site) in Poughkeepsie, Dutchess County, New York. The Vibration and Settlement Monitoring Plan identifies the relevant damage criteria, the proposed monitoring locations, and the mitigation procedures for responding to observed exceedances of the vibration and settlement thresholds. The remedial activities will be implemented according to the New York State Department of Environmental Conservation (NYSDEC) Decision Document (March 2016) to address the residuals remaining from the former MGP operations.

The Vibration and Settlement Monitoring Plan is intended to be a framework within which the vibration and settlement levels from the excavation and sheet piling activities are documented and recorded. Any changes to the proposed remedial construction activities and the proposed construction phases will be updated in a revised Vibration Monitoring Plan, as necessary. Evaluations of the vibration and settlement monitoring programs and requirements by the Engineer should be completed periodically to determine if more or less monitoring is required.

This Vibration and Settlement Monitoring Plan does not preclude the use of other mitigation technologies or techniques designated in other design documents.

1.1 Vibration Basics

A source (such as using a backhoe hammer to demolish large pieces of subsurface concrete structures) can excite the adjacent ground, creating vibration waves that propagate (or move) through the various soil and rock strata. This could potentially reach the foundations of nearby buildings, street, sidewalks and then spread throughout parts of the structure. Although ground-borne vibration is sometimes noticeable outdoors, it is almost exclusively an indoor problem. The effects of ground-borne vibration can include perceptible movement of the building floors, rattling of windows, shaking of items on shelves or hanging on walls, and rumbling sounds. Vibration effects can range from simply causing annoyance to people inside buildings to minor (cosmetic) damage to walls and ceiling to major structural damage, although the latter is an extremely rare occurrence. Differences in these vibration outcomes are related to the magnitude of the vibration that propagates to nearby structures. Vibrations of greater magnitude may cause building or structure damage, but vibrations at much lower levels may be felt by humans but be too low to cause building damage.

Construction activity can result in varying degrees of ground vibration, depending on the equipment and methods employed. Operation of construction equipment causes ground vibrations that spread through the ground and diminish in strength with distance. Buildings founded on the soil or underground structures in the vicinity of the construction site respond to these vibrations with varying results, ranging from no perceptible effects at the lowest levels, low rumbling sounds and perceptible vibrations at moderate levels, and slight damage at the highest levels. Ground vibrations from construction activities do not often reach the levels that can damage structures, but they can achieve the audible and perceptible ranges in buildings very close to the site. A possible exception is the case

of fragile buildings or structure, many of them old, where special care must be taken to avoid damage. The construction vibration action levels include special consideration for such buildings.

Evaluation criteria for determining vibration impacts due to construction activities include thresholds for (1) human perception, annoyance, and interference, (2) damage to fragile and historical buildings, and (3) damage to underground utility pipelines and structures. Although no standardized vibration criteria for construction activities have been established, exceedances of certain vibration levels may typically cause community reactions.

Vibration energy is measured as peak particle velocity (PPV). PPV is appropriate for evaluating vibration associated with construction activities and the resulting stresses that potentially are damaging to buildings. PPV represents the maximum instantaneous positive or negative peak of a vibration signal, and it is commonly used to measure and evaluate impulse vibrations associated with blasting or pile driving. The U.S. Bureau of Mines (USBM) publishes guidelines based on PPV that are frequently used to set acceptable vibration limits for various types of structures.

Excessive vibration levels from construction activities, although temporary in duration, may create a nuisance condition at nearby receptors. Ground-borne vibrations from construction activities rarely reach the levels that can damage structures; however, the vibrations can reach the audible and perceptible ranges in buildings that are very close to those experienced on the active work area [FTA, 2006]. The types of construction activities that typically generate the greatest vibrations are blasting and impact pile driving. As proposed a vibratory hammer will be used for the sheet pile driving activity at the site which typically generates fewer vibrations than impact hammer. Pile driving activity is expected to last approximately for eight weeks.

Annoyance from vibration occurs when vibration levels exceed the thresholds of human perception. These criteria are well below vibration levels at which damage might be expected to occur in buildings. In other words, a person may be able to feel or perceive vibration at levels that are much lower than levels that could cause structural damage [Jones and Stokes, 2004]. It is important to note that the term "damage," when used in the context of acceptable levels of ground vibrations, refers to threshold damage as defined by the USBM. The definition states "the occurrence of cosmetic damage; that is, the most superficial interior cracking of the type that develops in all homes independent of blasting." It should be noted that the occurrence of PPV values greater than the threshold value does not imply that cosmetic cracking will occur but that it could occur.

1.2 Receptors

Structures located near the site will be subject to a pre- and post-construction survey and vibration monitoring to document their condition before and after the remedial construction. If an access agreement is already in place, the vibration monitoring points will be placed as close as practicable to the existing structures. For properties where an access agreement has not been negotiated, the vibration monitoring points will be placed near the property line of the potentially affected property.

The following structures are located near the site which will be monitored for any impacts resulting from construction activities:

- Pedestrian bridge (Wa kway Over the Hudson) elevator tower located on the southern portion of the site
- Gas infrastructure and gas utility crossing located on the northern portion of the site

- Electric transmission transition station, electric utility crossing, and fiber optic line crossings located on the southern portion of the site.

2.0 Vibration and Settlement Monitoring

The remedial activities will include site preparation work, pre-trenching, sheet pile installation, excavation of shallow soils on the site, dredging of MGP-impacted sediments from the Hudson River, grading of the river slope, capping of impacted sediments that can't be dredged, and restoration. Vibration and settlement monitoring will be required for these activities.

The vibration and settlement monitoring will be conducted in coordination with the Contractor. The Contractor shall provide the proposed construction sequence to the Construction Manager a minimum of 2 weeks prior to mobilization to allow mobilization for vibration monitoring. The remediation Contractor shall provide a minimum of 48 hours' notice to the Construction Manager before they mobilize. The Contractor shall provide a minimum of 24 hours' notice to the Construction Manager before the Contractor begins any demolition or hammering activities. The Construction Manager shall coordinate placement of the vibration and settlement monitoring equipment with the Contractor.

Monitoring equipment proposed for the construction vibration measurements include InstanTel Minimate Plus seismographs, the GeoSonics 3000EZplus, or their equivalents. All the monitoring equipment will be utilized according to the manufacturer's specifications.

2.1 Vibration Monitoring

Vibration monitoring may be conducted at the following locations as shown in Figure 2-1:

- Adjacent to the gas infrastructure and subsurface gas utility crossing on the northern portion of the site (V1)
- Adjacent to the underwater gas utility crossing on the northern portion of the site (V2)
- Adjacent to the subsurface electric utility crossing, and fiber optics crossing located on the southern portion of the site (V3)
- Adjacent to the Walkway Over the Hudson elevator tower located on the southern portion of the site (V4)
- Adjacent to the electric transmission transition station (V5)
- Following construction, the Barrier/Bulkhead Wall located on the western portion of the site (V6)

Monitoring locations were selected based on their close proximity to the site and sensitivity to ground-borne vibration. Additional vibration monitoring locations may be added to the north and east of the project site during pre-construction vibration monitoring, if necessary.

2.1.1 Pre-construction Vibration Monitoring

Given the setting around the site, it is important to conduct a pre-construction vibration survey at selected monitoring locations.

2.1.1.1 Vibration Baseline Survey

A pre-construction vibration survey will be undertaken for a week prior to the initiation of any activity at the site. The vibration monitors will record the vector sum of the wave velocity in inches per second. The objective of the vibration survey is to establish baseline ground motions caused by vehicular and train traffic near the sensitive structures selected surrounding the Site. These vibration levels will be compared to vibrations induced during construction and may be used to revise threshold limitations for vibration induced damage.

2.1.1.2 Existing Structures Condition Survey

An existing condition survey of the surrounding structures will be performed. Pre-construction surveys will include inspecting structure's foundations, exterior, and interior elements and documenting any pre-existing defects such as cracks, settlement, subsidence, corrosion, or water damage. Defects that should be monitored during construction will be noted and, where appropriate, crack monitors will be installed prior to the start of construction. The surveys will be documented through notes and photography to establish the pre-construction conditions. At the end of construction, a similar set of photos will be taken for comparison. Post-construction photographs will be compared with the initial pre-construction photographs to establish the growth of any pre-existing cracks or the onset of any new cracks.

2.1.2 Construction Period Vibration Monitoring

At each location, the peak vibration levels from the construction equipment and trucks will be measured during each construction phase. The following construction phases are currently proposed as part of the remedial activity:

- Equipment mobilization;
- Above ground site clearing activities including any demolition and hammering activities;
- Subsurface structure demolition activities, trenching, and soil excavation;
- Pile driving and installation of subsurface barrier/bulkhead wall;
- Sediment dredging in the Hudson River; and
- Placement of caps on and around the utility corridors and Hudson River Slope

The vibration monitoring plan consists of performing vibration monitoring of construction activities, evaluating it daily, and preparing weekly summary reports of the vibration readings. The vibration monitoring plan will include:

- Developing a layout for the vibration monitoring equipment and a schedule for vibration monitoring. The equipment layout will involve placing monitoring units equipped with geophones capable of triaxial displacement measurements next to buildings and/or structures adjacent to the construction areas. The monitoring units will be installed and secured at locations where firm subgrade is exposed. The layout and schedule will depend on the Contractor's proposed construction sequence.
- Performing continuous vibration monitoring during each of the construction phases to adequately document the ground-borne vibration from the construction activities. American Association of State Highway and Transportation Officials (AASHTO) R-8-96 uses USBM published vibration damage research and establishes a PPV of 2 inches per second (in/s) as the "structural damage threshold limit". PPV limits will be developed that will be used as

“warning action limits” and “stop work action limits”. These limits will be used as threshold values for the vibration mitigation plan during the construction activities. Vibration levels will be monitored to detect construction operations that cause vibrations above the recommended vibration action limits.

- Performing vibration monitoring continuously from the start to end of each construction work shift. Data recording will commence prior to the start of each shift. At the end of each shift, data collected will be downloaded and reviewed, and a summary report will be submitted.
- If the vibration “warning action limit,” which may be revised after pre-construction survey is completed, is exceeded, the situation will be reviewed, and the cause of the vibration will be identified. A corrective action plan will be formulated, implemented, and monitored. If the vibration “stop work action limit” is exceeded or abnormal monitoring data is recorded, work should stop to allow for review of the vibration data. In the event that the vibrations exceed the stop work action limit, the monitoring units will set off an alarm that will signal for the stop of construction work. The causes of vibration will be investigated and vibration mitigation procedures can then be reviewed and implemented as needed before work proceeds. Additional monitoring units might be required to further mitigate excessive vibrations.
- At the end of construction, the data will be summarized in a report. Summary tables of the warning/action events recorded during the monitoring duration and associated causes observed for each event will be included in this summary memo.

2.1.3 Construction Period Crack Monitoring

Additionally, tell-tale crack monitors (or strain gauges) may also be installed on nearby structures (where necessary) to document the status of existing hairline cracks. Prior to the start of the construction activities, baseline crack gauge measurements may be conducted to identify and document any existing hairline cracks on the structures. Furthermore, crack monitor (or strain gauge) measurements will be collected twice a week, typically midweek during the construction activities and at the end of the week after construction is completed. However, if high vibration levels are recorded during the actual vibration monitoring, more frequent crack monitoring may be conducted at the discretion of the Engineer.

The vibration and crack monitoring program will depend on the remedial Contractor’s construction plan and duration of the construction operations. The number and locations of vibration monitoring units will depend on the location and extent of the construction activities being monitored. Depending on levels observed during initial construction, additional vibration monitoring units may be required to evaluate the vibration levels. Periodic evaluations of the vibration monitoring program will be completed to determine the program’s adequacy and continuing requirements.

2.2 Settlement Monitoring

Settlement monitoring will be conducted adjacent to the gas infrastructure, electric transmission transition station, and the elevator to the Walkway over the Hudson during pre-trenching, sheet pile installation, excavation, backfilling, and sediment dredging operations and if necessary during other activities. Monitoring shall be performed for both (x, y) horizontal directions using a GPS system with a ground station. The settlement (vertical displacement) shall be measured using a conventional or digital level. Initial monitoring of each settlement point shall start within 24 hours of sheet pile installation and excavation to obtain a baseline and then when the excavation occurs as described below. The instrument reading schedule for the settlement points shall be:

- Three initial sets of readings prior to any site activities.

- Daily when sheet pile installation is within 20 feet of the settlement points.
- Daily when excavating and dredging is within 15 feet of the settlement points.
- Increase frequency of readings where action limits are reached.
- Monthly after completion of backfilling or until measurements remain stable over three consecutive readings.
- Concurrence to stop monitoring must be obtained from the Engineer in writing.

Additional settlement points may be installed if required by the Engineer. Additional monitoring shall be performed as directed by the Engineer.

3.0 Vibration and Settlement Damage Thresholds

3.1 Vibration Damage Thresholds

The damage thresholds are defined for various buildings and structures depending on the structure's strength and ability to absorb ground-borne vibration. Since all buildings are continually exposed to seismic vibration, buildings are generally designed to withstand elevated ground-borne vibration levels without resulting in stress fractures or hairline cracks. For most buildings, the likelihood of damage or even minor cosmetic damage is highly unlikely unless there are pre-existing faults with the building structure, and there is nearby blasting or excessive pounding from construction equipment (such as pile driving). The generally accepted damage criteria listed in Table 3-1 were developed by the USBM [Nicholls, 1971] as well as European construction and tunnel authorities [Association of Swiss Highway Professionals, 1992].

By definition, the peak particle velocity (PPV) is the maximum rate of change of position (displacement) with respect to time as measured on the ground surface. The velocity amplitudes are given in units of inches per second (in/s) zero to peak amplitude. The frequency of vibration is the number of oscillations that occur in 1 second. The frequency units given are in hertz (cycles per second). The dominant frequency is usually defined as the frequency at the maximum particle velocity, which will be calculated visually from the seismograph strip chart for the half cycle that has its peak, the maximum velocity. The particle velocity must be recorded in three (3) mutually perpendicular axes, with the maximum allowable peak particle velocity being in the maximum measure along any of three axes.

Thresholds of vibration induced cracking are generally site specific and depend on the type and age of the structure, frequency of ground vibration, and type of soil supporting the structure. Research by the USBM and other investigative groups have established criteria relating the occurrence of structural damage to certain frequencies and level of ground motion. According to the USBM, within the range of four (4) to 12 hertz, the maximum particle velocity recommended to preclude the threshold damage to plaster-on-wood for old structures is 0.5 in/s and for historic monuments is 0.1 in/s.

Table 3-1 Construction Vibration Damage Criteria (in PPV)

Land-Use/Building Category	Applicable Receptor ID	Peak Particle Velocity ¹	
		mm/s	in/s
Industrial buildings (and other structures of substantial construction)	Electric transition station, Walkway Over the Hudson elevator tower, Bulkhead	100	4
Residential, new construction	--	50	2
Residential, poor condition	Gas infrastructure, utility crossings	25	1
Residential, very poor condition	--	12.7	0.5
Reinforced-concrete, steel, or timber (no plaster)	--	12.7	0.5
Engineered concrete and masonry (no plaster)	--	7.62	0.3
Non-engineered timber and masonry buildings	--	5.08	0.2
Historic buildings	--	3	0.12
Historic buildings, poor condition	--	2	0.08

¹ PPV levels are reported in both metric and SAE units including millimeters per second (mm/s) and inches per second (in/s).

According to a USBM blasting study, a PPV of 2.0 in/sec is the threshold level at which minor structural damage may begin to occur in 0.01 percent of structures. A PPV of 2.0 in/s is the generally accepted threshold of minor cosmetic damage due to repeated construction activities, and there is research that suggests that many single family residences and other structures can sustain substantially higher vibration levels without damage. However, recent research has demonstrated that historic or fragile buildings or structures may be more susceptible to potential damage at lower levels depending on the condition of their foundations. As per the City of Poughkeepsie Zoning and Land Use Regulation Chapter 19 of the Code, it is recommended that construction shall not create vibration that is perceptible beyond the property boundary. The Federal Transit Administration Office of Planning and Environmental document Transit Noise and Vibration Impact Assessment, recommends a threshold limit of ppv 0.5 in/sec for reinforced concrete and steel. Therefore, based on the structure types identified for each monitoring location and the above discussion, the vibration threshold limits to be used for stop work action are summarized in Table 3-2.

Table 3-2 Preliminary Vibration Threshold Limits (in PPV)

Vibration Monitoring Location	Vibration Threshold Limits (PPV)	
	Warning Action Limit (in/sec)	Stop Work Action Limit (in/sec)
General, Observational	-	Any complains (third party) or visible movement of objects within neighboring structures, residences, buildings, business or utilities.
V1 – Gas Infrastructure	1.0	2.0
V2 – Gas Utility Crossings	0.5	1.0
V3 – Electric Utility Crossings	0.5	1.0
V4 – Elevator Tower	1.0	2.0
V5 – Electric Transmission Transfer Station	2.0	4.0
V6 – Barrier/Bulkhead Wall	2.0	4.0

Please note that these threshold limits may be revised following the pre-construction baseline vibration monitoring.

Construction vibration should be assessed quantitatively in cases where there is significant potential for impact from construction activities. Such activities include blasting, pile-driving, vibratory compaction, demolition, and drilling or excavation in close proximity to sensitive structures. For reference purposes, a quantitative assessment of the vibration from the site construction activities has been completed below. The recommended procedure for estimating vibration impact from construction activities is as follows:

- Select the equipment and associated vibration source levels at a reference distance of 25 feet from Table 3-3.
- Make the propagation adjustment according to the following formula [(this formula is based on point sources with normal propagation conditions); FTA, 2006]:

$$PPV_{equip} = PPV_{ref} \times (25/D)^{1.5}$$

Where:

$PPV_{(equip)}$ = peak particle velocity in in/s of the equipment adjusted for distance

$PPV_{(ref)}$ = reference vibration level in in/s at 25 feet from Table 3-3

D = distance from the equipment to the receiver.

Apply the vibration damage threshold limits from Table 3-2.

Table 3-3 Vibration Source Levels for Construction Equipment

Equipment		Peak Particle Velocity at 25 ft	
		mm/s	in/s
Pile Driver (impact)	upper range	38.5	1.518
	typical	16.3	0.644
Pile Driver (sonic)	upper range	18.6	0.734
	typical	4.3	0.170
Clam shovel drop (slurry wall)		5.1	0.202
Hydromill (slurry wall)	in soil	0.2	0.008
	in rock	0.4	0.017
Vibratory Roller		5.3	0.210
Hoe Ram		2.3	0.089
Large bulldozer		2.3	0.089
Caisson drilling		2.3	0.089
Loaded trucks		1.9	0.076
Jackhammer		0.9	0.035
Small bulldozer		0.1	0.003

The above methodology was used to calculate the expected vibration levels at the receptors neighboring the site. The results are presented below for the remediation construction equipment that would result in the maximum vibrations (pile driver) with the exception of barrier/bulkhead wall:

Table 3-4 Vibration Impacts Expected at Neighboring Receptors

Receptor	Distance (feet)	Peak Particle Velocity	
		mm/s	in/s
V1 – Gas Infrastructure	35	11.23	.0.443
V2 and V3 – Utility Corridors	10	73.52	2.9
V4 – Elevator Tower	35	11.23	0.443
V5 – Electric Transmission Transfer Station	35	11.23	0.443
V6 – Barrier/Bulkhead Wall	10	20.95	0.83

A full list of vibration impacts expected from all construction equipment used during the site remediation for all receptors is included as Appendix A of this document. Please note that a typical value for a pile driver (sonic) was used based on knowledge of site-specific lithography.

As shown in Table 3-4, the installation of sheet piles has the highest probability of exceeding the stop work action limit. Special controls shall be implemented during sheet pile installation to minimize the risk of damage to nearby building and underground structures including:

- Periodic monitoring of any crack gauges installed on the structures during installation of sheet piles
- Telemetric (text messages) alerts for any Warning and Stop Work Action Limits exceedances during installation of sheet piles
- Use of a pneumatic pile driver if mitigation measures listed in Section 4 fail to minimize vibration levels

It is known that vibrations can densify soils. However, only certain soils are susceptible to this type of densification, and very high vibration levels are required to produce this effect. Two extreme soil types have been studied for vibration-induced densification, and they represent the worst case of base materials. These soils are saturated, cohesionless soil and loose, fine, cohesionless soil. Saturated cohesionless soils are susceptible to a vibration effect called liquefaction. Studies observed liquefaction at 2.0 in/s [Seed, 1979; Veyera, 1987], while collapse of loose fine cohesionless soil was found to be insignificant at 2.0 in/s. Both vibration studies subjected the samples to high amplitudes for tens to hundreds of cycles. Long duration vibration events at this amplitude are not typical at construction sites. Thus, if required, a stop work action limit of 0.5 in/s for the utility crossings, which is a conservative limit, may be established following the results of the pre-construction baseline vibration monitoring, to ensure protection of the utilities.

3.2 Settlement Thresholds

The settlement threshold levels will be uniform for various locations across the site and shall be as follows:

Table 3-5 Settlement Limits

Instrument Type	Depth (Feet)	Action Levels (Feet)		
		Warning Action Limit 1	Warning Action Limit 2	Stop Work Action Limit
Settlement Point	0	0.04	0.06	0.08

4.0 Exceedance and Mitigation

Notwithstanding the specific vibration levels specified herein, vibration mitigation measures listed below will be utilized to minimize, to the greatest extent feasible, the vibration levels near the site:

- Develop and implement a vibration-monitoring program in order to compare vibration levels at nearby sensitive receptors during construction (this document) with the pre-construction baseline condition as well as the vibration threshold limits established in Table 3-1;
- Inform people living and working in the vicinity about construction method, possible effects, quality control measures, precautions to be used, and channels of communication available to them;
- Route truck traffic and heavy equipment to avoid impacts to sensitive receptors;
- Operate earth-moving equipment on the site as far away from vibration-sensitive sites as possible;
- Debris removal, earth-moving, and ground-impacting operations so as not to occur in the same time period. The total vibration level produced are significantly less when each vibration source operates separately;
- Minimize the use of impact devices, such as jackhammers, pavement breakers, and hoe rams to remove obstructions or debris where possible;
- Avoid vibratory rollers and packers near sensitive areas;
- Schedule work to limit weekend and nighttime work; and
- Minimize the duration of any high vibration activities.

The following procedures are recommended if a measured level exceeds the damage thresholds or if the crack monitors indicate new or larger cracks.

4.1 Vibration and Settlement Mitigation

Detailed review and interpretation of all geotechnical and structural monitoring data will be made in order to determine whether movements, settlements, tilt, and vibrations have reached an action limit.

In the event that a "Warning Action Limit" is reached:

- The Contractor must meet with the Project Team to discuss the need for mitigation actions;
- The Engineer will prepare a plan of action for the activity or activities responsible for the exceedance;
- If directed by the Engineer or the Construction Manager, the Contractor must implement the plan of action within 24 hours of submittal of the plan of action so that the "Stop Work Action Limit" is not reached; and
- The monitoring frequency of the affected instrument will be increased and additional instruments installed, if necessary.

In the event that a “Stop Work Action Limit” is reached:

- The Contractor must cease all construction activities and meet with the Project Team to discuss the need for mitigation actions;
- The Engineer will prepare a plan of action for the activity or activities responsible for the exceedance;
- If directed by the Engineer or the Construction Manager, the Contractor must implement the plan of action within 12 hours of submittal of the plan of action so that the “Stop Work Action Limit” is not exceeded further; and
- The Contractor will install additional instrumentation, if necessary.

The definition of the required action that must be taken should any geotechnical or structural instrument achieve an action limit is defined in Table 4-1 below:

Table 4-1 Required Action for “Warning Action Limit” or “Stop Work Action Limit”

Action Limit	Required Action
Warning Action Limit	The value of the geotechnical or structural instrumentation reading at which the Engineer and Contractor jointly assess the necessity of either or all of the following: <ul style="list-style-type: none"> • Evaluating the activity responsible for the exceedance • Altering the method of excavation or construction • Altering the rate of excavation or construction • Altering the sequence of excavation or construction • Changing excavation or construction machinery • Increasing frequency of monitoring of affected instrument
Stop Work Action Limit	The value of the geotechnical or structural instrumentation reading at which the Engineer and Contractor jointly assess the necessity of either or all of the following: <ul style="list-style-type: none"> • Making site and affected properties secure • Taking necessary predetermined measures to mitigate movements and assure the safety of the public and the Work • Restarting excavation or construction operations <p>The Stop Work Action Limit for each instrument represents the absolute maximum permissible ground or structure movement and the maximum permissible vibration.</p>

The on-site crack monitors (strain gauges) will be checked to determine if there has been any change since the last recording. Work procedures will be evaluated and modified to prevent further exceedance of the monitoring criteria. All work activities will only proceed at the discretion of the Engineer and after the source of the exceedance has been determined and corrected.

4.2 Crack Monitoring Exceedance

In the event that there is a change in an existing crack or if new cracks are observed during visual inspections, all site work should stop until the Engineer can evaluate the integrity of the monitored structures. Similar to the vibration monitoring exceedance, the recent activities and machinery will be evaluated to determine the correlation between the ongoing activities and the onset of structural

cracks. Work procedures will be evaluated and modified to prevent further exceedance of the monitoring criteria. All work activities will only proceed at the discretion of the Engineer and after the source of the exceedance has been determined and corrected.

5.0 References

Association of Swiss Highway Professionals, 1992. "*Effects of Vibration on Construction*," Committee VSS 272, Swiss Standards SN640-312a, Zurich, Switzerland. April 1992.

Federal Transit Administration, 2006. "*Transit Noise and Vibration Impact Assessment*," FTA-VA-90-1003-06, U.S. Department of Transportation, Washington, DC. May 2006.

Jones & Stokes. 2004. "*Transportation-and construction-induced vibration guidance manual*," J&S 02-039, Sacramento, CA. Prepared for California Department of Transportation, Noise, Vibration, and Hazardous Waste Management Office, Sacramento, CA. June, 2004.

Nicholls, H.R., Johnson, C.F., and Duvall, W. I., 1971. "*Blasting Vibrations And Their Effects on Structures*," U.S. Bureau of Mines Bulletin 656, 1971.

Seed, H.B., 1979. "*Soil Liquefaction and Cyclic Mobility Evaluation for Level Ground During Earthquakes*," J. Geotech. Engg Div., ASCE pg. 201-255, vol. 105, no. GT2. 1979.

Veyera, G.E., and Charlie, 1987. "*Liquefaction of Shock Loaded Saturated Sand*," Chapter in Soil Dynamics and Liquefaction, Ed. by A.S. Cakmak, Developments in Geotechnical Engineering, No. 42, Elsevier. 1987.

Figure

Figure 2-1 Approximate Vibration Monitoring Locations

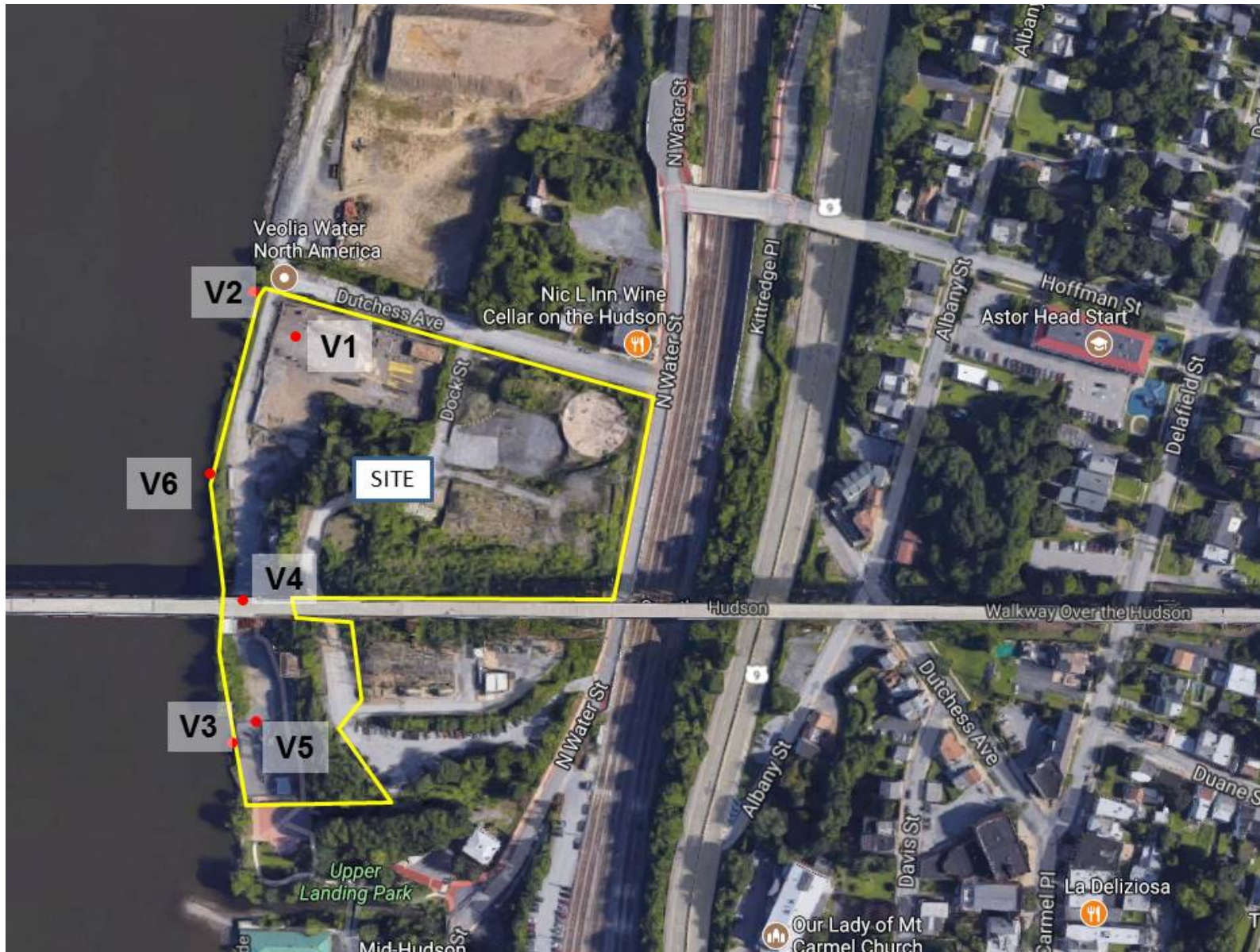

Appendices

Appendix A

Expected Vibration Levels at Receptor Locations

Appendix A - Vibration and Settlement Monitoring Plan
Expected Vibration Levels at Receptor Locations
CHGE Former North Water Street MGP Site
Poughkeepsie, New York

Receptor	Distance	Equipment	Threshold Peak Particle Velocity at 25 ft		Expected Peak Particle Velocity at Receptor	
			mm/s	in/s	mm/s	in/s
V2 – Utility Crossings	10	Vibratory Roller	5.3	0.2	20.95	0.83
	10	Pile Driver (Sonic typical)	4.3	0.2	17.00	0.67
	10	Pile Driver (Sonic upper range)	18.6	0.7	73.52	2.90
	10	Hoe Ram	2.3	0.1	9.09	0.35
	10	Large Bulldozer	2.3	0.1	9.09	0.35
	10	Loaded Truck	1.9	0.1	7.51	0.30
	10	Jackhammer	0.0	0.3	0.14	1.26
	10	Small Bulldozer	0.1	0.0	0.40	0.01
V1 – Gas Infrastructure, V3 – Elevator Tower, V4 – Electric Transmission Transition Station, V5 - Bulkhead	35	Vibratory Roller	5.3	0.2	3.20	0.13
	35	Pile Driver (Sonic typical)	4.3	0.2	2.60	0.10
	35	Pile Driver (Sonic upper range)	18.6	0.7	11.23	0.44
	35	Hoe Ram	2.3	0.1	1.39	0.05
	35	Large Bulldozer	2.3	0.1	1.39	0.05
	35	Loaded Truck	1.9	0.1	1.15	0.05
	35	Jackhammer	0.0	0.2	0.02	0.12
	35	Small Bulldozer	0.1	0.0	0.06	0.00

Appendix E of CERP

Land and Marine Transportation Plan



Environment

Prepared for:
Central Hudson
Gas and Electric Corporation
Poughkeepsie, New York

Prepared by:
AECOM
New York, New York
June 2018

Transportation Plan

**Former CHGE-North Water Street Manufactured Gas Plant Site
Poughkeepsie, New York
Site ID No. C314070**

Contents

- 1.0 Introduction..... 1-1**
- 2.0 Truck Selection 2-1**
- 3.0 Truck Loading 3-1**
- 4.0 Transportation Routes..... 4-1**
- 5.0 Transportation Management 5-1**
 - 5.1 Truck Staging5-1
 - 5.2 Traffic Control5-1
 - 5.3 Driver Code of Conduct.....5-1
 - 5.4 Traffic Accidents and Releases.....5-1
- 6.0 Traffic Control during Marine Activities 6-1**
 - 6.1 Lighting.....6-1
 - 6.2 Coordination and Communication.....6-1
 - 6.3 Local Notice to Mariners.....6-1
- 7.0 Barge Loading..... 7-1**
- 8.0 Barge Transportation..... 8-2**
 - 8.1 Accidental Releases.....8-2

List of Appendices

Appendix A Truck Routes

Appendix B Instruction to Truckers

Appendix C Local Notice to Mariners

List of Acronyms

BIC	Business Integrity Commission
CHGE	Central Hudson Gas & Electric Corporation
cy	cubic yards
DNAPL	Dense non-aqueous phase liquid
GVW	Gross Vehicle Weigh
MGP	Manufactured Gas Plant
NYCRR	New York Codes, Rules, and Regulations
ROW	Right-of-way
Site	Former North Water Street MGP site, Poughkeepsie, Dutchess County, New York

1.0 Introduction

Central Hudson Gas & Electric Corporation (CHGE) is responsible for the remediation of the North Water Street Former Manufactured Gas Plant (MGP) site (site) located in Poughkeepsie, Dutchess County, New York. The site is approximately 13 acres in size and is fenced on the northern, eastern, and southern sides. The remediation will involve installation of a subsurface barrier/bulkhead wall, excavation and management of impacted soils, grading of the river slope, capping of the river slope and underwater utility crossings, dredging of the river sediments impacted by the former MGP operations, off-site disposal of impacted material and restoration.

Soil and sediments will be disposed of at one of the following disposal facilities or at a landfill:

1. Environmental Soil Management Inc. (ESMI) of New York, located at 304 Tow Path Road, Fort Edward, NY 12828.
2. Bayshore Recycling, located at 75 Crows Mill Rd., Keasbey, NJ 08832.
3. Clean Earth of New Castle, Inc., Pyles Lane, New Castle, Delaware 19720.
4. Clean Earth of Southeast Pennsylvania, 7 Steel Road East, Morrisville, PA 19067.

The remediation work will require the transport of the following materials:

- Export approximately 6,000 tons of impacted soil from land side remediation
- Export approximately 500 tons of debris from upland work
- Import approximately 6,000 tons of clean backfill for land side restoration
- Export approximately 5,000 tons of debris from river slope grading and dredging activities
- Export approximately 90,000 tons of impacted sediments from the dredging activities
- Import approximately 90,000 tons of sand/fill for the river slope grading and restoration of the dredge areas
- Mobilize and demobilize remedial equipment

Approximately 20 to 25 trucks are expected each day during landside excavation and each material truck may weigh approximately 35 tons. Material and equipment deliveries during the landside as well as the water site remedial activities will not exceed the weight limit of 54 tons for the Kingston-Rhinecliff Bridge or 55 tons of the Mid-Hudson Bridge. One or two barges carrying approximately 700 cubic yards (cy) of sediments are expected to travel to the pre-treatment facility each day during dredging activities.

Transportation required for this work will be performed in accordance with all local, state, and federal laws, as well as with the Remedial Design/Remedial Action (RD/RA) Work Plan. Transportation must meet the requirements described in this document. These requirements include truck selection (Section 2), truck loading (Section 3), transportation routes (Section 4),

transportation management (Section 5), traffic control during marine activities (Section 6), barge loading (Section 7), and barge transportation (Section 8).

2.0 Truck Selection

Either 18-wheel trailer dumps or tri-axle dump trucks will be used dependent upon local bridge/road conditions and project site conditions, contract documents, and availability. The Contractor shall verify all allowable truck weights for this project.

All trucks will have the required licenses and permits, including 6 New York Codes Rules and Regulations (NYCRR) Part 364 Waste Transporter Permits.

3.0 Truck Loading

The soil that will be removed from the project site during the upland work will be excavated and loaded in a manner that minimizes the release of odors. Excavated soils will be monitored and managed using odor control methods, such as the application of odor-control foam. In keeping with this plan, the loading and shipping of impacted soils will also need to be performed in a manner that minimizes the potential for the release of odors.

The impacted soil will be loaded with a conventional excavator or front-end loader onto trucks. Each truck will be lined with 10-mil-thick polyethylene sheeting prior to loading by the on-site remediation Contractor. Use of the liner minimizes the need for decontamination of the truck after contaminated soil is dumped at the disposal or treatment facility and provides containment for any residual liquids which may be associated with wet soils. The plastic liner is also wrapped over loaded soils and closed to minimize odors during transport.

Note that soils with free liquids will not be shipped from the project site. Saturated soils, if any, will be allowed to drain before being loaded onto trucks for shipping.

The trucks will be loaded directly from excavations, or from stockpiles, to ensure impacted material is not spread throughout the project site. Odor-suppressing foam will be applied to the excavations, stockpiles, and material on the trucks, when necessary. Additionally, an odor-masking agent may also be applied to the impacted soil while loading and stockpiling activities are ongoing to reduce nuisance odors.

All trucks will be covered with a tarpaulin supplied by the trucking firm prior to leaving the project site to ensure that no material is blown off the truck during transportation and to minimize the release of odors. Each truck will be dispatched from the project site with the appropriate bill-of-lading or manifest and will follow the prescribed transportation route to its destination.

After loading, all trucks will enter a decontamination pad where all residual soil will be removed from the truck body, wheels, and tires to ensure that impacted soil from the project site is not tracked onto the streets. Tracking, dropping, or depositing of soil or any other material onto local, county, or state roadways or paved parking areas by or from any vehicle is prohibited.

4.0 Transportation Routes

Trucks will be required to enter and exit the project site via designated entrance. Truck Routes to and from the ESMI facility are included in Appendix A as the soils from the landside work will be shipped to this facility. The truck routes are developed in consultation with the City of Poughkeepsie and in accordance with the rules of the New York State Department of Transportation.

5.0 Transportation Management

Truck traffic will be managed in a way to minimize any impact on the vehicular and pedestrian traffic. Specific instructions to contract truckers are provided in Appendix B of this document.

5.1 Truck Staging

An on-site staging area, located on the lower terrace of the site, has been identified for trucks waiting to be loaded or to deliver. Trucks cannot be staged on the streets adjoining the project site or in any other areas awaiting entrance into the loading area. Due to tight project site conditions, truck staging will be limited to three (3) trucks prior to loading if space is available on-site. Trucks staged on-site shall not be allowed to idle longer than 5 minutes in duration and shall be in compliance with 6 NYCRR subparts 217-3.

Drivers will be responsible for communicating with on-site staff to ensure that the site is ready to accept them.

5.2 Traffic Control

Due to the narrow nature of the surrounding streets and the limited maneuverability of trailer/tri-axle dump rigs, there will need to be certified flaggers present whenever trucks enter or exit the project site. All flaggers will be equipped with the appropriate signage or flags.

The Contractor will be responsible for coordinating, via radio or telephone, careful arrival of trucks to avoid congestion.

Extreme caution must be taken when entering and exiting the project site, as there is likely to be both vehicular and pedestrian traffic very close to the work area.

5.3 Driver Code of Conduct

All truck drivers are expected to adhere to the following code of conduct:

- Drivers must treat safety as a top priority at all times
- Drivers must obey all applicable laws (no speeding, no double parking, following special speed limits around school, etc.)
- Drivers must act in a professional manner (no spitting, no cursing, following project personnel and flagger's instructions, etc.)

5.4 Traffic Accidents and Releases

In the event that a loaded truck is involved in an incident that results in a release of the transported materials, the cleanup shall follow local and State DOT spill response procedures. The remediation Contractor will contact all involved parties immediately, including the Construction Manager, Engineer (AECOM), and CHGE representatives. The remediation Contractor and/or transporter will be responsible for the cleanup of any releases which may occur during transport to the disposal facility.

It will be the responsibility of the remediation Contractor to keep all haul routes and public rights-of-way (ROW) free of any project site materials due to transportation operations.

6.0 Traffic Control during Marine Activities

During in-water work, including installation of sheet piles for the barrier/bulkhead wall, river slope grading, river slope and underwater utility capping, dredging, and restoration activities, the contractor shall develop a marine work area plan including all the work locations and the marine equipment deployed and update it as the work progresses. Boundaries of the work location shall be given in latitude and longitude as well as distance from the shoreline and distance to the navigable channel. Description of stations for inspection boats and monitoring buoys should be shown. The area designated for public access to the shore will be kept clear at all times. The work plan shall be submitted to the Engineer and Construction Manager for review and approval.

6.1 Lighting

Vessel/marine equipment lighting shall be in accordance with Navigation Rules – 33 Code of Federal Regulations Part 83. Specifically required lights for moored barges and moored power driven vessels as well as vessels underway (power driven and towed) shall be identified and in place. Lights on turbidity barriers shall be installed incrementally along the length of the barriers. The work equipment navigational lighting plan shall be submitted to the Engineer for review and approval. A copy of the Navigation Rules (33 CFR Part 83) must be aboard and readily available on all self-propelled vessels 12 meters or greater in length.

6.2 Coordination and Communication

The contractor must maintain a 24/7 operational number at all times (during working and non-working hours). This number must be monitored at all times to receive emergency calls. This number will be included in the Local Notice to Mariners item (discussed below). Prior to commencement of work in the water the contractor shall establish contact with the Dutchess County Sheriff's Office marine unit, LT Mike Dampf, mdampf@dutchessny.gov, (845) 486-3800, apprising them of the marine plan and ascertain any special coordination requirements. As dictated by Dutchess County Sheriff's office, periodic updates via telephone or email of the status of the marine construction activity will be given.

6.3 Local Notice to Mariners

The contractor shall summarize the marine work plan in an article to be published in the First Coast Guard District's Local Notice to Mariners (LNM) weekly marine advisory to be submitted a minimum of two (2) weeks prior to the commencement of work. The LNM article shall include all applicable information in the format included in Appendix C in a word document and sent to Mary Swanson at LNLM@uscg.mil or fax at 617-223-8291.

7.0 Barge Loading

The impacted sediments and debris from the river will be dredged using an environmental bucket and within a containment cell to minimize dripping and spreading of impacts. The operator must keep the environmental bucket closed and lower it over the barge significantly to minimize splashing. Odor suppressant foam will be used as needed to suppress the odors. If the dredging activities are suspended for more than one hour and at the end of the day, the barge will be kept covered to minimize odors and vapors.

8.0 Barge Transportation

After decanting, the barge will be transported to the facility identified by the disposal facility for off-loading and processing before being transported to the inland thermal facility. The barge will follow the selected route and will stay in constant contact with the Contractor during transport. The barge will be covered before leaving the project area and must stay covered during the transportation to minimize potential spread of impacts and odors.

8.1 Accidental Releases

In the event that a loaded barge is involved in an incident that results in a release of the transported sediments, the cleanup shall follow local, State, and marine spill response procedures. The remediation Contractor will contact all involved parties immediately, including the Construction Manager, Engineer (AECOM), and CHGE representatives. The remediation Contractor and/or transporter will be responsible for the cleanup of any releases which may occur during transport to the disposal facility.

Appendix A

Truck Routes

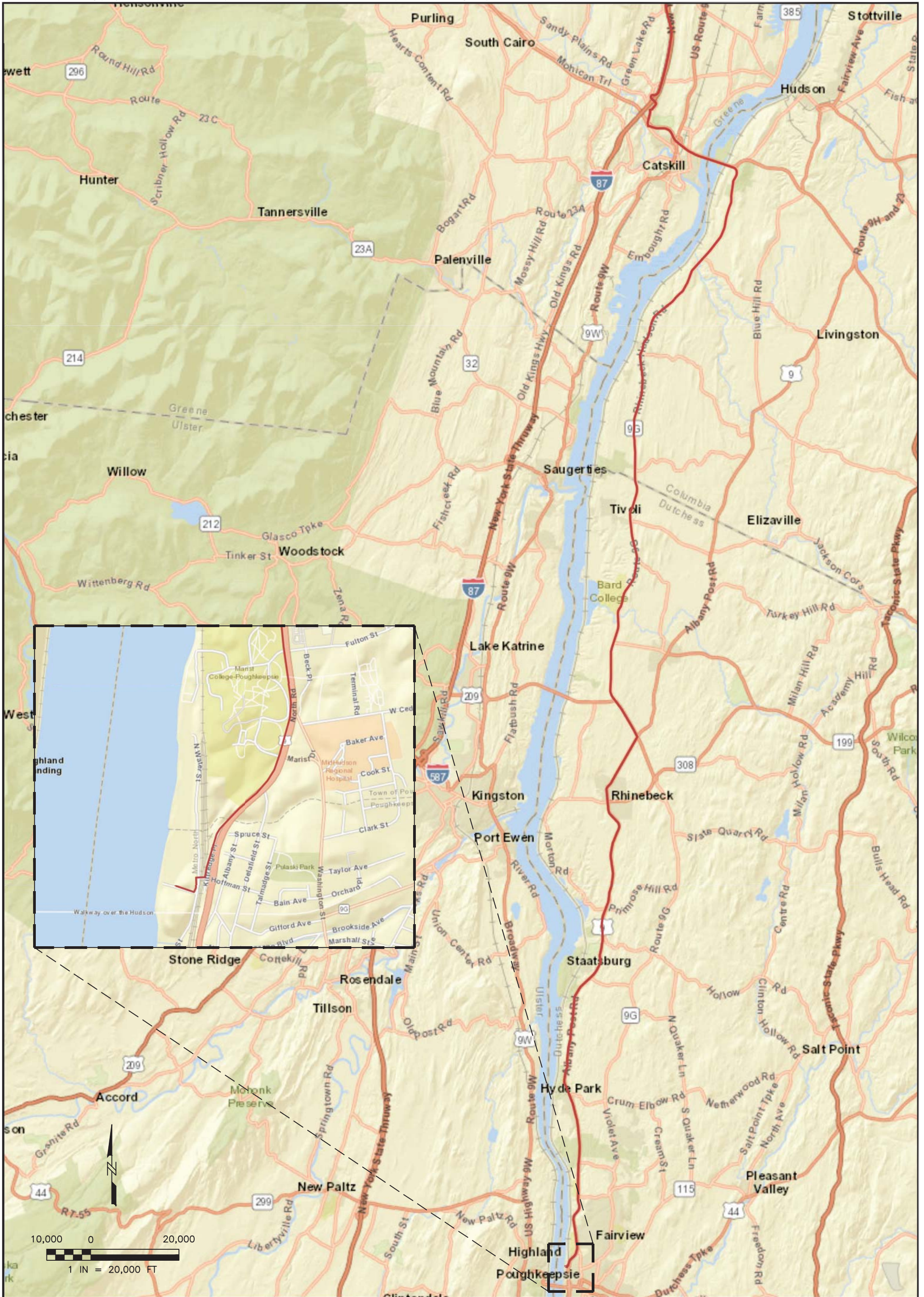

MAP SOURCE: Esri, HERE, Garmin, USGS, Intermap, INCREMENT P, NRCAN, Esri Japan, METI, Esri China (Hong Kong), Esri Korea, Esri (Thailand), NGCC, (C) OpenStreetMap contributors, and the GIS User Community



CENTRAL HUDSON GAS & ELECTRIC
POUGHKEEPSIE, NY
60540671

PROPOSED TRUCK ROUTE
TO THE SITE

DATE: 06/18/2018

DRWN: ELH

FIGURE 1



MAP SOURCE: Esri, HERE, Garmin, USGS, Intermap, INCREMENT P, NRCAN, Esri Japan, METI, Esri China (Hong Kong), Esri Korea, Esri (Thailand), NGCC, (C) OpenStreetMap contributors, and the GIS User Community



CENTRAL HUDSON GAS & ELECTRIC
POUGHKEEPSIE, NY
60540671

PROPOSED TRUCK ROUTE
FROM THE SITE

DATE: 06/18/2018

DRWN: ELH

FIGURE 1

Appendix B

Instruction to Truckers

Guidelines for Truck Drivers

1. All truckers must provide permits at the staging area.
2. Trucks are not allowed onsite before 7 AM for any reason. Trucks must offload at the disposal facility the same day truck is loaded.
3. The truck route will be developed prior to construction activities for the site.
4. A staging area will be identified at the former CHGE-North Water Street MGP site for trucks waiting to be loaded or to deliver. Trucks will remain in staging area until radioed by contractor.
5. Stay in cab during loading, shut off the truck once in loading position.
6. Each truck will be lined with 10-mil-thick polyethylene sheeting prior to loading.
7. All trucks will be covered with a tarpaulin supplied by the trucking firm prior to leaving the Site.
8. After loading, all trucks will enter a decontamination pad where all residual soil will be removed from the truck body, wheels, and tires.
9. Trucks must off load at the disposal facility the same day they are loaded, must leave Site with enough time before facility closes.
10. All trucking traffic must obey New York State traffic regulations. In the event of a violation, immediate action, up to and including permanent driver dismissal from the project will be taken. Particular care must be taken in sensitive areas, along residential streets, and near historic structures.
11. In the event that a loaded truck is involved in an incident that results in a release of the transported materials, the cleanup shall follow local and State Department of Transportation spill response procedures and Contractor shall be notified immediately. Truck must remain at the scene of the accident or spill until clean up is complete.

Appendix C

Local Notice to Mariners



Homeland
Security

U.S. COAST GUARD
First Coast Guard District



DATE: _____

NAME: _____

PHONE NUMBER: _____

EMAIL ADDRESS: _____

COMPANY NAME: _____

TYPE OF WORK: _____

WATERWAY & LOCATION WHERE WORK WILL BE DONE: _____

LAT/LONG: (Degrees, Minutes, Thousandths of seconds) _____

BEGINNING/ENDING DATES: _____

HOURS OF OPERATION: _____

EQUIPMENT ON SCENE: _____

PASSING ARRANGEMENTS/Time to move vessels to not impede navigation: _____

RADIO FREQUENCY (IF USED): _____

DISPOSAL SITE (IF USED): _____

NOAA Chart Number for the area: _____

EMAIL FORM TO LN@uscg.mil or fax to Mary Swanson @ 617-223-8291 two weeks before the work is to begin. The LNM (Local Notice to Mariners) can be found online at: <http://www.navcen.uscg.gov>.

Appendix C

Pre Design Investigation Geotechnical Boring Logs and Sediment Precharacterization Observation Logs

		<i>Client</i>		Central Hudson Gas & Electric			Boring ID:	GT17-100
		<i>Project Number:</i>		60540671.1A				
		<i>Site:</i>		North Water Street - MGP				
<i>Project Manager:</i>		S. Pandya		<i>Logged By:</i>	J. Christopher		<i>Drilling Method:</i>	Hollow Stem Auger
<i>Drilling Co.:</i>		ADT		<i>Driller:</i>	L. Darrow		<i>Ground Elev.(NAVD):</i>	0.8 (est)
				<i>Date Started:</i>	6/14/2017		<i>Depth of Boring:</i>	49.3 ft
				<i>Date Finished:</i>	6/15/2017		<i>Water Level:</i>	~ 5fbg
<i>Depth</i>	<i>Blow Count</i>	<i>Lab Sample</i>	<i>Recovery</i>	<i>Moisture</i>	<i>PID</i>	<i>USCS</i>	<i>Classification of Material</i>	
<i>feet</i>		<i>ID</i>	<i>%</i>		<i>ppm</i>			
5	NA	NA	NA	UNK	UNK	FILL	Preleared by hand to 5fbg without logging	
7	2	NA	27%	WET	0.6	FILL	loose, brown to black, wet, fine to coarse SAND, with fine to coarse Gravel, with little Silt, with little brick fragments, no odor, no staining	
	3				3.9			
9	1	NA	33%	WET	7.3	FILL	loose, brown to black, wet, fine to coarse SAND, with fine to coarse Gravel, with little Silt, with little brick fragments, moderate MGP odor, no staining	
	5				27.5			
11	3	NA	33%	WET	61.1	FILL	woody debris, with some fine Sand, with some Silt, moderate MGP odor	
	5				52.7			
13	19	NA	35%	WET	36.9	FILL	woody debris, with some fine Sand, with some Silt, weak MGP odor	
	4				10.4			
15	9	NA	40%	WET	59.2	FILL	woody debris, with some fine Sand, with some Silt, moderate MGP odor	
	12				6.8	SW/GW	loose, brown-grey, wet, fine to medium SAND, with some fine to medium Gravel (shale fragments), with some Silt, weak MGP odor, no staining	
17	3	NA	38%	WET	10.2	SW	loose, brown, wet, fine to medium SAND, with little fine to medium Gravel (shale fragments), with little Silt, no odor, no staining	
	9				6.1			
19	5	NA	29%	WET	0.9	SW	loose, brown, wet, fine to medium SAND, with little fine to medium Gravel (shale fragments), with little Silt, no odor, no staining	
	6				0.1			
21	5	GT17-100 (19-21)	71%	WET	0.0	SW		
	3				0.0			
	1							
	6							

		<i>Client</i>		Central Hudson Gas & Electric			Boring ID:	GT17-100
		<i>Project Number:</i>		60540671.1A				
		<i>Site:</i>		North Water Street - MGP				
						<i>Drilling Method:</i>	Hollow Stem Auger	
						<i>Ground Elev.(NAVD):</i>	0.8 (est)	
<i>Project Manager:</i>	S. Pandya	<i>Logged By:</i>	J. Christopher	<i>Date Started:</i>	6/14/2017	<i>Depth of Boring:</i>	49.3 ft	
<i>Drilling Co.:</i>	ADT	<i>Driller:</i>	L. Darrow	<i>Date Finished:</i>	6/15/2017	<i>Water Level:</i>	~ 5fbg	
23	7	NA	50%	WET	0.0	SW	loose, brown, wet, fine to medium SAND, with some vegetation debris, with little fine to medium Gravel (shale fragments), with little Silt, no odor, no staining	
	7			MOIST	0.0	CL		medium stiff, moist, brown-grey, CLAY, with little Silt, no odor, no staining (@22.5')
25	2	NA	52%	WET	0.0	GW	loose, brown-grey, wet, fine to medium SAND and GRAVEL, with little Silt, no odor, no staining	
	9				0.0			
27	3	NA	42%	WET	0.0	GW	very soft, wet, brown, SILT with some Clay, with little fine Sand, no odor, no staining	
	1				0.0	ML		
29	W	GT17-100 (27-29)	92%	WET	0.0	ML	very soft, wet, brown, SILT with some Clay, with little fine Sand, no odor, no staining	
	O				0.0			
31	0	NA	69%	WET	0.0	ML	soft, wet, brown, SILT with some Clay, with little fine Sand, no odor, no staining	
	1			MOIST	0.0			
33	W	NA	0%	NA	NA	---	No Recovery	
	O				NA			
35	W	NA	71%	DRY	4.1	WOOD	wood, solid, whole (stump?)	
	H				3.9			
37	12	NA	23%	DRY	10.1	WOOD	wood, solid, pulverized, strong cedar odor	
	5				21.1			
39	4	NA	100%	WET	0.0	ML	very soft, wet, brown, SILT with some Clay, with little fine Sand, no odor, no staining	
	3			MOIST	0.0			
41	6	NA	0%	NA	NA	---	No Recovery	
	3				NA			
43	3	NA	100%	WET	0.0	ML	very soft, wet, brown-grey, SILT, with trace Clay, with woody debris lens (~2" @42.5', @44.75'), organic odor, no staining	
	2				1.4			
45	6	NA	29%	WET	0.0	ML	very soft, wet, brown-grey, SILT, with trace Clay, with woody debris lens (~2" @42.5', @44.75'), organic odor, no staining	
	3				0.0			
47	14	NA	0%	NA	NA	---	No Recovery	
	6				NA			
49	17	NA	100%	WET	0.0	ML	very soft, wet, brown-grey, SILT, with trace Clay, with woody debris lens, organic odor, no staining	
	36				0.0	GW	medium tight, wet, dark grey, shale fragments, no odor, no staining	
49.3	50/0 3'	NA	83%	WET	0.0	GW	Bedrock @ 49.3ft	
51								

		<i>Client</i>		Central Hudson Gas & Electric			Boring ID:	GT17-101	
		<i>Project Number:</i>		60540671.1A					
		<i>Site:</i>		North Water Street - MGP					
						<i>Drilling Method:</i>	Hollow Stem Auger		
						<i>Ground Elev.(NAVD):</i>	7.15 (est)		
<i>Project Manager:</i>	S. Pandya		<i>Logged By:</i>	J. Christopher		<i>Date Started:</i>	6/12/2017	<i>Depth of Boring:</i>	31.3 ft
<i>Drilling Co.:</i>	ADT		<i>Driller:</i>	L. Darrow		<i>Date Finished:</i>	6/12/2017	<i>Water Level:</i>	~ 7fbg
<i>Depth</i>	<i>Blow Count</i>	<i>Lab Sample</i>	<i>Recovery</i>	<i>Moisture</i>	<i>PID</i>	<i>USCS</i>	<i>Classification of Material</i>		
<i>feet</i>		<i>ID</i>	<i>%</i>		<i>ppm</i>				
2	15	NA	71%	DRY	0.0	FILL	(0 - 0 25') loose, dry, grey, medium GRAVEL, with some medium to coarse Sand, no odor, no staining loose, dry, black and brown, anthropogenic fill, coal, ash, fine to medium Sand, some fine to medium Gravel, no odor, no staining		
	12				0.0				
4	10	NA	88%	DRY	0.0	FILL			
	5				0.0				
6	5	NA	50%	DRY	0.0	FILL			
	4			MOIST	56.2				
	2								
8	2	NA	60%	MOIST	124.0	FILL			
	2			WET	271.0				
	3								
10	2	NA	69%	WET	41.6	FILL			
	4			MOIST	78.6				
	3								
12	4	NA	17%	MOIST	12.7	FILL			
	6			WET	20.2				
	5								
14	3	GT17-101 (13-14)	35%	WET	77.8	SW			
	3				56.1				
	3								
16	7	NA	52%	WET	28.3	GW			
	3				10.9				
	3								
18	3	NA	33%	WET	11.7	GW			
	4				9.6				
	3								

		<i>Client</i>		Central Hudson Gas & Electric		Boring ID:		GT17-101			
		<i>Project Number:</i>		60540671.1A							
		<i>Site:</i>		North Water Street - MGP							
						<i>Drilling Method:</i>		Hollow Stem Auger			
						<i>Ground Elev.(NAVD):</i>		7.15 (est)			
<i>Project Manager:</i>	S. Pandya		<i>Logged By:</i>	J. Christopher		<i>Date Started:</i>	6/12/2017		<i>Depth of Boring:</i>	31.3 ft	
<i>Drilling Co.:</i>	ADT		<i>Driller:</i>	L. Darrow		<i>Date Finished:</i>	6/12/2017		<i>Water Level:</i>	~ 7fbg	
20	2	NA	42%	WET	15.2	SW	medium loose, fine to medium SAND, with some fine to medium Gravel (shale fragments), slight coal tar odor				
	18			MOIST	4.6						
22	7	NA	58%	MOIST	1.9	SW					
	9				0.7	GW					
24	11	NA	46%	WET	0.4	GW		tight, dark grey, heavily weathered shale, slight coal tar odor, no NAPL			
	42				1.1						
26	5	NA	58%	WET	3.9	SW					
	2				25.6						
28	10	GT17-101 (27'-28')	96%	WET	57.9	SP			medium tight, dark grey to black, medium SAND, strong coal tar odor, NAPL		
	7				28.1	SW			tight, dark grey, fine to coarse SAND, with some fine to medium shale fragments, moderate coal tar odor (NAPL 26.5' - 27')		
30	6	NA	48%	WET	10.1	SW	tight, dark grey, fine to coarse SAND, with some fine to medium shale fragments, with little Silt, moderate coal tar odor, no NAPL Bedrock @ 31.3ft				
	8				8.8						
31.3	4	NA	63%	WET	5.1	SW					
	9				2.8						
32	50/0.3'										

		<i>Client</i>		Central Hudson Gas & Electric			Boring ID:	GT17-102				
		<i>Project Number:</i>		60540671.1A								
		<i>Site:</i>		North Water Street - MGP								
							<i>Drilling Method:</i>	Hollow Stem Auger				
							<i>Ground Elev.(NAVD):</i>	8 (est)				
<i>Project Manager:</i>	S. Pandya		<i>Logged By:</i>	J. Christopher		<i>Date Started:</i>	6/13/2017	<i>Depth of Boring:</i>	26.6 ft			
<i>Drilling Co.:</i>	ADT		<i>Driller:</i>	L. Darrow		<i>Date Finished:</i>	6/13/2017	<i>Water Level:</i>	~8fbg			
<i>Depth</i>	<i>Blow Count</i>	<i>Lab Sample</i>	<i>Recovery</i>	<i>Moisture</i>	<i>PID</i>	<i>USCS</i>	<i>Classification of Material</i>					
<i>feet</i>		<i>ID</i>	<i>%</i>		<i>ppm</i>							
2	5	NA	71	DRY	00	FILL	medium loose, dry, brown to black, fine SAND and SILT, with some medium Sand, with little brick fragments, with little ash, no odor, no staining (@5' - 6' some orange coloration)					
	4				00							
4	4	NA	69	DRY	00	FILL						
	5				00							
6	2	NA	88	DRY	00	FILL						
	1			MOIST	00							
8	2	NA	63	MOIST	00	FILL						
	3				00							
10	3	NA	40	WET	00	FILL				loose, wet, orange-brown, fine to medium SAND, with some fine shale Gravel, with little ash, no odor, no staining		
	2				00							
12	6	NA	48	WET	00	GW	loose, wet, brown, fine SAND, with fine to medium Gravel (shale fragments), with little Silt, no odor, no staining					
	3	GT17-102 (11-14)			13							
14	9		38	WET	0.6	GW						
	10	00										
16	3	NA	33	WET	00	GW	loose, wet, dark grey to black, fine SAND, with fine to medium Gravel (shale fragments), with little Silt, organic odor, no staining					
	4				00							
18	3	GT17-102 (17-18)	79	WET	00	GW	medium stiff, brown-grey CLAY, with trace Silt, no odor, no staining					
	1			MOIST	00					CL		
20	1	NA	52		MOIST	00					CL	
	3			WET	00	GW				loose, wet, dark grey to black, fine SAND, with fine to medium Gravel (shale fragments), with little Silt, organic odor, no staining		

		<i>Client</i>		Central Hudson Gas & Electric		Boring ID:	GT17-102
		<i>Project Number:</i>		60540671.1A			
		<i>Site:</i>		North Water Street - MGP			
						<i>Drilling Method:</i>	Hollow Stem Auger
						<i>Ground Elev.(NAVD):</i>	8 (est)
<i>Project Manager:</i>	S. Pandya		<i>Logged By:</i>	J. Christopher		<i>Date Started:</i>	6/13/2017
<i>Drilling Co.:</i>	ADT		<i>Driller:</i>	L. Darrow		<i>Date Finished:</i>	6/13/2017
	2 8 9 10	NA	50	WET	00 00	GW	medium tight, wet, grey, fine SAND and fine to medium GRAVEL (shale fragments), with little Silt, no odor, no staining
22	10 11 9 9	NA	73	WET	00 00	SP SW	loose, wet, brown, medium SAND, no odor, no staining
24	4 9 7 4	NA	33	WET	00 00	SW	loose, wet, light brown, fine to coarse SAND, with fine to medium Gravel, with some Silt, no odor, no staining
26	15 50/0.1	NA	---	WET	00	GW	medium loose, wet, grey to brown, fine to medium SAND, and fine to medium GRAVEL (shale fragments), with little Silt, no odor, no staining
26.6							Bedrock @ 26.6fbg
28							

		<i>Client</i>		Central Hudson Gas & Electric			Boring ID:	GT17-103		
		<i>Project Number:</i>		60540671.1A						
		<i>Site:</i>		North Water Street - MGP						
							<i>Drilling Method:</i>	Hollow Stem Auger		
							<i>Ground Elev.(NAVD):</i>	7.6 (est)		
<i>Project Manager:</i>		S. Pandya		<i>Logged By:</i>		J. Christopher		<i>Date Started:</i> 6/15/2017		
<i>Drilling Co.:</i>		ADT		<i>Driller:</i>		L. Darrow		<i>Date Finished:</i> 6/15/2017		
								<i>Depth of Boring:</i>		
								21 8 ft		
								<i>Water Level:</i>		
								~ 6fbg		
<i>Depth</i>	<i>Blow Count</i>	<i>Lab Sample</i>	<i>Recovery</i>	<i>Moisture</i>	<i>PID</i>	<i>USCS</i>	<i>Classification of Material</i>			
<i>feet</i>		<i>ID</i>	<i>%</i>		<i>ppm</i>					
6	4	NA	33	MOIST	61.7	FILL	Precleared by hand to 4fbg without logging. loose, moist, black and brown, fine to coarse SAND, with some brick fragments, with some Silt, wi h little ash, moderate coal tar odor, no staining			
	2				11.4					
	3									
8	4	NA	35	WET	21.2	FILL				
	6				4.1	GW				
	3									
10	2	NA	21	WET	0.0	GW	loose, wet, brown-grey, fine to medium shale fragments, with little fine to medium Sand, slight coal tar odor, no staining			
	2				0.0					
	2									
12	4	NA	13	WET	2.1	GW			loose, wet, grey to black, fine to medium shale fragments, with little fine to medium Sand, organic odor, no staining	
	2				0.0					
	1									
14	1	GT17-103 (12-15)	40	WET	2.1	ML	soft, wet, dark grey to black SILT, with some fine Sand, wi h trace Clay, organic odor, no staining			
	1				0.0					
	3									
16	1	NA	54	WET	0.0	ML				
	1				0.0	GW				
	6									
18	5	GT17-103 (16-19)	67	WET	0.0	GW	loose, wet, dark grey to black, fine to medium GRAVEL, with some fine Sand, with some Silt, with little glass fragments, no odor, no staining			
	6				0.0					
	11									
20	7	NA	60	WET	0.1	GW			medium loose, wet, dark grey to black, fine to medium GRAVEL, with some fine Sand, with some Silt, wi h little glass fragments, no odor, no staining	
	12				0.0					
	14									
21.8	5	NA	63	WET	0.0	GW				
	7				0.0					
	8									
22	50/0 3'						Bedrock @ 21.8fbg			

		<i>Client</i>		Central Hudson Gas & Electric			Boring ID:	GT17-104	
		<i>Project Number:</i>		60540671.1A					
		<i>Site:</i>		North Water Street - MGP					
						<i>Drilling Method:</i>	Hollow Stem Auger		
						<i>Ground Elev. (NAVD)</i>	6.6 (est)		
<i>Project Manager:</i>	S. Pandya		<i>Logged By:</i>	J. Christopher		<i>Date Started:</i>	6/15/2017	<i>Depth of Boring:</i>	20.9 ft
<i>Drilling Co.:</i>	ADT		<i>Driller:</i>	L. Darrow		<i>Date Finished:</i>	6/15/2017	<i>Water Level:</i>	~ 7fbg
<i>Depth</i>	<i>Blow Count</i>	<i>Lab Sample</i>	<i>Recovery</i>	<i>Moisture</i>	<i>PID</i>	<i>USCS</i>	<i>Classification of Material</i>		
<i>feet</i>		<i>ID</i>	<i>%</i>		<i>ppm</i>				
5	NA	NA	NA	NA	NA	NA	Prcleared by hand to 5 fbg without logging		
7	2	NA	29	MOIST	0.0	GW	loose, moist, brown and grey, fine to medium GRAVEL, with little fine to medium Sand, no odor, no staining		
	1				0.0				
9	6	NA	35	WET	0.0	GW	loose, wet, brown and grey, fine to medium GRAVEL, with little fine to medium Sand, no odor, no staining		
	8				0.0				
11	4	NA	25	WET	0.0	ML	soft, wet, black, SILT, with little fine Sand, organic odor, slight sheen, no staining		
	2				0.0				
13	1	NA	13	WET	0.0	ML	medium tight, wet, grey, fine SAND, with some Silt, no odor, no staining		
	1				0.0	SP			
15	3	GT17-104 (13-15)	75	MOIST	0.0	ML	medium tight, moist, grey, SILT, with some fine Sand, no odor, slight sheen, no staining (@ 16.5' little Clay)		
	2				0.0				
17	2	NA	60	MOIST	0.0	ML			
	7				0.0				
19	7	GT17-104 (17-19)	63	MOIST	0.0	GW	medium tight, moist, grey to dark grey, fine to medium Gravel (weathered shale), with little fine Sand, with little Silt, no odor, no staining		
	11				0.0				
20.9	7	NA	65	WET	0.0	GW			
	8				0.0				
21	50/0.4						Bedrock @ 20.9 fbg		

		Client		Central Hudson Gas & Electric			Boring ID:	GT17-105			
		Project Number:		60540671.1A							
		Site:		North Water Street - MGP							
Project Manager:		S. Pandya		Logged By:		J. Christopher		Date Started:	6/21/2017	Drilling Method:	Vibracore
Drilling Co.:		ATL		Driller:		B. Perry		Date Finished:	6/21/2017	Ground Elev. (NAVD):	-12 (EST)
Depth		Blow Count		Lab Sample		Recovery		Moisture		PID	
feet		ID		%		ppm		USCS		Classification of Material	
2	W O R	NA	0	WET	NA	---	No Recovery				
4	W O R	NA	8	WET	00 00	GW	loose, wet, black and brown, fine to medium GRAVEL, no odor, no staining (fines washed out?)				
6	W O H 2 2 3	NA	25	WET	00	GW	loose, wet, brown, fine GRAVEL, with some Silt, no odor, no staining				
					00		loose, wet, black, fine GRAVEL, with some Silt, no odor, no staining				
8	1 4 3 7	GT17-105 (6-8)	54	WET	00	GW	loose, wet, black-grey, fine GRAVEL, with some Silt, no odor, no staining				
					00						
10	W O H 4 1 W O H	NA	21	WET	00	SW	loose, wet, black, medium to coarse SAND, with little fine Gravel, no odor, no staining				
					00						
12	3 2 4 2	GT17-105 (10-14)	50	WET	00	SW	loose, wet, black, medium to coarse SAND, with some fine Gravel, with little Silt, no odor, no staining				
					00						
14	3 8 W O H W O R	GT17-105 (10-14)	38	WET	00	SW	loose, wet, black, medium to coarse SAND, with some fine Gravel, with trace Silt, no odor, no staining				
					00						
16	1 3 6 18	NA	48	WET	00	SW					
					00		CL	medium soft, wet, brown-grey CLAY, no odor, no staining			
						GW	loose, wet, brown-grey, fine to med GRAVEL, with little Silt, no odor/staining				
18	5 6 1 1	NA	8	WET	00	ML	soft, wet, brown-grey, S LT, with little Clay, no odor, no staining				
		GT17-105 (17-20)			00						
20	7 8 3 2	GT17-105 (17-20)	29	WET	00	ML	soft, wet, brown-grey, SILT, with little coarse Sand, with little Clay, no odor, no staining				
					00						
22	W O R W O H W O H W O H	NA	0	WET	NA	---	No Recovery				

		<i>Client</i>		Central Hudson Gas & Electric			Boring ID:	GT17-105			
		<i>Project Number:</i>		60540671.1A							
		<i>Site:</i>		North Water Street - MGP							
<i>Project Manager:</i>		S. Pandya		<i>Logged By:</i>		J. Christopher		<i>Date Started:</i>	6/21/2017	<i>Drilling Method:</i>	Vibracore
<i>Drilling Co.:</i>		ATL		<i>Driller:</i>		B. Perry		<i>Date Finished:</i>	6/21/2017	<i>Ground Elev. (NAVD):</i>	-12 (EST)
								<i>Depth of Boring:</i>	69.5 ft	<i>Water Level:</i>	0 fbg
<i>Depth</i>	<i>Blow Count</i>	<i>Lab Sample</i>	<i>Recovery</i>	<i>Moisture</i>	<i>PID</i>	<i>USCS</i>	<i>Classification of Material</i>				
<i>feet</i>		<i>ID</i>	<i>%</i>		<i>ppm</i>						
24	W O H	NA	0	WET	NA	---	No Recovery				
26	W O R	NA	67	WET	00 00	ML	soft, wet, brown-grey, S LT, with little Clay, no odor, no staining				
28	W O R W O H	NA	63	WET	00 00	ML					
30	W O R W O R W O H	NA	75	WET	00 00	ML					
32	W O R W O H 3 7	NA	100	WET	00 00	ML					
34	W O H W O H W O H 3	NA	100	WET	00 00	ML	soft, wet, brown-grey, SILT, no odor, no staining				
36	W O R 1 5 7	NA	100	WET	00 00	ML					
38	W O R W O H 3 5	NA	75	WET	00 00	ML					
40	W O R 1 4 5	NA	54	WET	00 00	ML					
42	W O H W O H 5 6	NA	0	WET	NA	---	No Recovery				
44	W O H W O H 4 6	NA	83	WET	00 00	ML	soft, wet, brown-grey, SILT, no odor, no staining				
46	W O R W O R 3 7	NA	88	WET	00 00	ML					
48	W O H 3 8 9	NA	67	WET	00 00	ML					
50	W O R	NA	100	WET	00 00	ML	soft, wet, brown-grey, SILT, with small roots, no odor, no staining				
69.5	NA	NA	NA	NA	NA	NA	Geotechnical sampling concluded at 50 fbg				
70							Bedrock @ 69.5 fbg				

		<i>Client</i>		Central Hudson Gas & Electric			Boring ID:	GT17-106
		<i>Project Number:</i>		60540671.1A				
		<i>Site:</i>		North Water Street - MGP				
						<i>Drilling Method:</i>	Vibracore	
						<i>Ground Elev.(NAVD):</i>	-9	
<i>Project Manager:</i>		S. Pandya		<i>Logged By:</i>		J. Christopher	<i>Date Started:</i>	6/27/2017
<i>Drilling Co.:</i>		ATL		<i>Driller:</i>		B. Perry	<i>Date Finished:</i>	6/27/2017
							<i>Depth of Boring:</i>	43.75 ft
							<i>Water Level:</i>	0 fbg
<i>Depth</i>	<i>Blow Count</i>	<i>Lab Sample</i>	<i>Recovery</i>	<i>Moisture</i>	<i>PID</i>	<i>USCS</i>	<i>Classification of Material</i>	
<i>feet</i>		<i>ID</i>	<i>%</i>		<i>ppm</i>			
2	WOR 3 3	NA	17	WET	0.2	SW	loose, grey, wet, fine to coarse SAND, with some Silt, with little fine to medium Gravel, no odor, no staining	
	0.0							
4	1 WOH 3 3	NA	13	WET	0.0	SW		
	0.4							
6	3 2 2	NA	0	---	---	---	No recovery	
	1							
8	2 1 3 2	NA	0	---	---	---	No recovery	
	2							
10	1 2 WOH WOH	NA	8	WET	16.4	WD	Wood	

12	WOR 1 WOH WOH	GT106 (10-14)	25	WET	38.2	ML	soft, wet, brown-grey, SILT, with trace Clay, moderate coal tar odor, no staining	
	31.7							
14	WOH 1 1 1		46	WET	52.2	ML		
	18.1							
16	5 1 WOH 1	NA	0	---	---	---	No recovery	

18	WOH 2 2 3	NA	42	WET	47.1	ML	soft, wet, brown-grey, SILT, with little Clay, with little coarse Sand, with trace brick fragments, moderate coal tar odor, no staining	
	29.2							

		Client		Central Hudson Gas & Electric			Boring ID:	GT17-106
		Project Number:		60540671.1A				
		Site:		North Water Street - MGP				
				Drilling Method:		Vibracore		
				Ground Elev.(NAVD):		-9		
Project Manager:		S. Pandya		Logged By:		J. Christopher		
Date Started:		6/27/2017		Depth of Boring:		43.75 ft		
Drilling Co.:		ATL		Driller:		B. Perry		
Date Finished:		6/27/2017		Water Level:		0 fbg		
Depth	Blow Count	Lab Sample	Recovery	Moisture	PID	USCS	Classification of Material	
feet		ID	%		ppm			
20	5 3 2 2	GT17-106 (18-23)	17	WET	14.2	FILL	loose, wet, black/brown/red, fine to coarse SAND, with some brick fragments and glass, with trace fine Gravel, slight coal tar odor, no staining	
22	7 9 4 2				16.1			
	21				13.3			FILL
24	2 3 2 2	NA	25	WET	10.2	FILL		
	3				21.4	WD		wood, moderate oil odor
26	8 2 WOR	GT17-106 (24-26)	83	WET	4.1	ML		medium tight, wet, grey, SILT, with little Clay, no odor, no staining
	WOR				1.8			
28	WOR WOR WOR WOR	NA	27	WET	8.6	ML		
	WOR				7.1			
30	WOR WOR WOR WOR	NA	33	WET	0.4	ML		
	WOR				0.2			
32	WOR WOH WOH WOH	NA	17	WET	0.0	ML	medium loose, wet brown-grey, SILT, with fine Sand, no odor, slight sheen, slight staining, some NAPL blebs present (trace shells @ 31.5 ft)	
	WOR				0.0			
34	WOR WOR WOH WOH	NA	88	WET	0.0	ML		
	WOR				0.0			
36	WOR WOR WOR WOR	NA	8	WET	0.0	ML		
	WOR				0.0			
38	WOH WOH WOH 1	NA	79	WET	0.0	ML		
	WOR				0.0			
38.75	WOR 50/0 5	NA	21	WET	0.0	GM	loose, wet, grey, fine GRAVEL (weathered shale), with some Silt, no odor, no staining	
40							Bedrock @ 38.75 fbg REC: 47"/60" = 78% RQD: 15.9"/60" = 27%	
42								
44								

		<i>Client</i>		Central Hudson Gas & Electric			Boring ID:	GT17-107	
		<i>Project Number:</i>		60540671.1A					
		<i>Site:</i>		North Water Street - MGP					
						<i>Drilling Method:</i>	Vibracore		
						<i>Ground Elev.(NAVD):</i>	-19.5 (est)		
<i>Project Manager:</i>	S. Pandya		<i>Logged By:</i>	J. Christopher		<i>Date Started:</i>	6/22/2017	<i>Depth of Boring:</i>	42 ft
<i>Drilling Co.:</i>	ATL		<i>Driller:</i>	B. Perry		<i>Date Finished:</i>	6/22/2017	<i>Water Level:</i>	0 fbg
<i>Depth</i>	<i>Blow Count</i>	<i>Lab Sample</i>	<i>Recovery</i>	<i>Moisture</i>	<i>PID</i>	<i>USCS</i>	<i>Classification of Material</i>		
<i>feet</i>		<i>ID</i>	<i>%</i>		<i>ppm</i>				
2	WOH 2	NA	27	WET	00	FILL	loose, dark grey, wet, fine to medium GRAVEL, with some fine to coarse Sand, with little Silt, with little brick fragments, no odor, no staining		
	1				00				
4	WOH 1	NA	10	WET	00	FILL			
	1				00				
6	4 3 1	NA	4	WET	00	FILL			
	1				00				
8	WOH 1 WOH 1	NA	0	WET	NA	---		No recovery	
10	6 2 1	NA	0	WET	NA	---		No recovery - rock in tip of sampler	
	3								
12	3 2 1	NA	0	WET	NA	---		No recovery - rock in tip of sampler	
	2								
14	1 5 3	NA	17	WET	00	FILL			
	4				00				
16	5 4 2	NA	0	WET	NA	---	No recovery - brick in tip of sampler		
	1								

		<i>Client</i>		Central Hudson Gas & Electric		Boring ID:	GT17-107
		<i>Project Number:</i>		60540671.1A			
		<i>Site:</i>		North Water Street - MGP			
						<i>Drilling Method:</i>	Vibracore
						<i>Ground Elev.(NAVD):</i>	-19.5 (est)
<i>Project Manager:</i>	S. Pandya	<i>Logged By:</i>	J. Christopher	<i>Date Started:</i>	6/22/2017	<i>Depth of Boring:</i>	42 ft
<i>Drilling Co.:</i>	ATL	<i>Driller:</i>	B. Perry	<i>Date Finished:</i>	6/22/2017	<i>Water Level:</i>	0 fbg
18	2 3 1 1	NA	29	WET	0.0 0.0	FILL	loose, dark grey, wet, fine to medium GRAVEL, with some fine to coarse Sand, with little Silt, with little brick fragments, no odor, no staining
20	2 1 1 2	NA	17	WET	0.0 0.0	FILL	
22	WOH 2 1 1	NA	0	WET	NA	---	No recovery
24	WOH WOH 45 49	NA	42	WET	14.6 21.4	WD	wood, strong cedar odor, some staining between plies
26	6 4 2 3	NA	0	WET	15.4	WD	No recovery - moderate coal tar odor on spoon, PID reading from barrel
28	4 1 WOH WOH	NA	0	WET	NA	---	No recovery
30	1 WOH WOH 1	GT17-107 (30-38)	0	WET	68.4	---	No recovery - PID reading from barrel
32	2 3 6 6		17	WET	0.0 0.0	GM	medium tight, dark grey, wet, SILT, with little fine to medium shale fragments, no odor, no staining
34	3 4 7 7		17	WET	0.0	GM	
36	1 1 2 2		0	WET	NA	---	No recovery - no odor on barrel
36.75	4 50/0.5		29	WET	0.0	GM	medium tight, dark grey, wet, SILT, with little fine to medium shale fragments, no odor, no staining
38							Bedrock @ 36.75 fbg REC: 60"/60" = 100% RQD: 39.5"/60" = 66%
40							
42							

		<i>Client</i>		Central Hudson Gas & Electric			Boring ID:	GT17-108
		<i>Project Number:</i>		60540671.1A				
		<i>Site:</i>		North Water Street - MGP				
						<i>Drilling Method:</i>		Vibracore
						<i>Ground Elev.(NAVD):</i>		-21.5 (est)
<i>Project Manager:</i>		S. Pandya		<i>Logged By:</i>		J. Christopher		<i>Date Started:</i> 6/23/2017
<i>Drilling Co.:</i>		ATL		<i>Driller:</i>		B. Perry		<i>Date Finished:</i> 6/23/2017
						<i>Depth of Boring:</i>		32.3 ft
						<i>Water Level:</i>		0 fbg
<i>Depth</i>	<i>Blow Count</i>	<i>Lab Sample</i>	<i>Recovery</i>	<i>Moisture</i>	<i>PID</i>	<i>USCS</i>	<i>Classification of Material</i>	
<i>feet</i>		<i>ID</i>	<i>%</i>		<i>ppm</i>			
2	WOR WOR WOR WOR	--	21	WET	0.0 0.0	ML	very soft, wet, brown, SILT, with trace fine Gravel, with trace fine Sand, no odor, no staining	
4	WOH WOH WOH	--	21	WET	0.0 0.0	GM	very soft, wet, brown, SILT, with some fine to medium Gravel, with trace fine Sand, no odor, no staining	
6	WOH WOH WOH WOH	--	25	WET	0.0 0.0	GM	very soft, wet, brown, SILT, with some fine to medium Gravel, with some fine to medium Sand, no odor, no staining	
8	WOH WOH WOH WOH	--	0	WET	-- --	--	No recovery	
10	WOH WOH WOH WOH	GT17-108 (8-13)	29	WET	0.0 0.0	ML	soft, brown-grey, wet, SILT, no odor, no staining	
12	WOH WOH WOH WOH		8	WET	0.0	ML		
14	WOH WOH WOH WOH		58	WET	9.4 16.8	ML		
16	WOR WOR WOH WOH	--	25	WET	4.6 0.0	ML FILL	loose, brown and black, wet, fine to coarse SAND, with some brick, fine Gravel, trace Silt, moderate coal tar odor	
18	WOH WOH WOH WOH	--	0	WET	-- --	--	No recovery	

		<i>Client</i>		Central Hudson Gas & Electric		Boring ID:		GT17-108	
		<i>Project Number:</i>		60540671.1A					
		<i>Site:</i>		North Water Street - MGP					
						<i>Drilling Method:</i>		Vibracore	
						<i>Ground Elev.(NAVD):</i>		-21.5 (est)	
<i>Project Manager:</i>		S. Pandya		<i>Logged By:</i>		J. Christopher		<i>Date Started:</i> 6/23/2017	
<i>Drilling Co.:</i>		ATL		<i>Driller:</i>		B. Perry		<i>Date Finished:</i> 6/23/2017	
								<i>Depth of Boring:</i> 32.3 ft	
								<i>Water Level:</i> 0 fbg	
20	W O H	---	17	WET	0.0	FILL	loose, brown and black, wet, fine to coarse SAND, with some brick, fine Gravel, trace Silt, moderate coal tar odor medium loose, grey, wet, fine to medium GRAVEL (shale fragments), with some Silt, no odor, no staining		
	2				0.0	GM			
22	W O H	GT17-108 (20-25)	21	WET	0.0	GM			
	13				0.0	GM			
24	2	---	8	WET	0.0	GM			
	1					GM			
26	1	---	42	WET	0.0	GM			
	1				0.0	GM			
27.3	6	---	29	WET	0.0	GM			
	17				0.0	GM			
28	50/0.3								
30									
32									
34									

Bedrock @ 27 3 fbg
 REC: 44"/60" = 73%
 RQD: 30.9"/60" = 52%

Physical Observations - Sediment Precharacterization

December 2017

CHGE Former North Water Street MGP Site

Poughkeepsie, New York



Dredge Prism	NAPL Observation (Ft below SS)	Obstruction Observation (Ft below SS)	Comments	Geological Observations
1	---	---	No issue	Clayey silt with woody debris - very soft
2	---	---	No issue	Clayey silt with woody debris - very soft
3	---	---	No issue	Clayey silt with woody debris - very soft
4				
5	2'	---	NAPL odor	Clayey silt with woody debris - very soft
6	0' - 2'	---	NAPL present	Sandy silt with woody debris, little gravel or slag, NAPL present
7				
8	1' - 4'	---	Visible product	Clayey silt with woody debris, NAPL stringers and strong odor
9	---	0' - 1'	coarse	Sandy Gravel with some silt, some slag
10	2' - 4'	---	Lots of visible product	Clayey silt with woody debris, some gravel and slag, heavy NAPL pockets
11	---	2'	Refusal at Location 18 3x	Clayey silt, obstruction at 2'
12	---	3'	coarse	Gravelly sand, with some Silt
13				
14	3' - 9'	---	Visible product	Clayey silt with woody debris, NAPL stringers and strong odor
15	---	---	No issue	Sandy silt with woody debris, little gravel or slag
16	---	---	No issue	Sandy silt with woody debris, little gravel or slag
17	---	---	No issue	Clayey silt with woody debris, some gravel and slag
18				
19	---	7'	obstruction	Clayey silt with gravel and slag
20				
21				
22	2' - 6'	---	Visible product and sheen and odor	Clayey silt, heavy NAPL pockets strong odor
23				
24	0' - 1'	---	Heavy sheen and strong odor	Clayey silt, heavy sheen, strong odor
25	---	---	No issue	Clayey silt with woody debris
26	0' - 1'	---	Visible product and sheen and odor	Clayey silt, NAPL pockets strong odor
27	---	---	No issue	Clayey silt with woody debris, some gravel and slag
28	---	---	No issue	Clayey silt with woody debris, some gravel and slag

Appendix D

Pre Design Investigation Geotechnical Samples Laboratory Results



Client:	AECOM		
Project:	North Water Street - MGP		
Location:	Poughkeepsie, NY	Project No:	GTX-306681
Boring ID:	---	Sample Type:	---
Sample ID:	---	Test Date:	07/20/17
Depth :	---	Tested By:	GA
		Checked By:	emm
		Test Id:	416538

Moisture Content of Soil and Rock - ASTM D2216

Boring ID	Sample ID	Depth	Description	Moisture Content, %
GT17-100	GT17- 100 (19-21)	19-21 ft	Moist, very dark gray silty sand with gravel	19.0
GT17-100	GT17- 100 (27-29)	27-29 ft	Moist, very dark brown clay	73.0
GT17-101	GT17- 101 (15-18)	15-18 ft	Moist, very dark gray gravel with silt and sand	12.6
GT17-101	GT17- 101 (27-28)	27-28 ft	Moist, very dark gray clayey sand with gravel	12.3
GT17-102	GT17- 102 (11-14)	11-14 ft	Moist, dark olive gray gravel with silt and sand	12.9
GT17-102	GT17- 102 (17-18)	17-18 ft	Moist, very dark brown silt	53.9
GT17-103	GT17- 103 (12-15)	12-15 ft	Moist, very dark gray sandy silt with gravel	58.4
GT17-103	GT17- 103 (16-19)	16-19 ft	Moist, very dark gray clayey gravel with sand	10.6
GT17-104	GT17- 104 (13-15)	13-15 ft	Moist, very dark brown silt	53.7
GT17-104	GT17- 104 (17-19)	17-19 ft	Moist, very dark gray clayey gravel with sand	13.6

Notes: Temperature of Drying : 110° Celsius



Client:	AECOM		
Project:	North Water Street - MGP		
Location:	Poughkeepsie, NY	Project No:	GTX-306681
Boring ID:	---	Sample Type:	---
Sample ID:	---	Test Date:	07/20/17
Depth :	---	Test Id:	416547
		Tested By:	GA
		Checked By:	emm

Moisture Content of Soil and Rock - ASTM D2216

Boring ID	Sample ID	Depth	Description	Moisture Content, %
GT17-105	GT17- 105 (6-8)	6-8 ft	Moist, very dark gray gravel with silt and sand	16.8
GT17-105	GT17- 105 (10-14)	10-14 ft	Moist, very dark gray sand with gravel	18.5
GT17-105	GT17- 105 (17-20)	17-20 ft	Wet, very dark gray clay	54.6
GT17-106	GT17- 106 (10-14)	10-14ft	Moist, very dark gray gravelly silt	65.3
GT17-106	GT17- 106 (18-23)	18-23 ft	Moist, very dark gray and pale yellow gravel with sand	16.2
GT17-106	GT17- 106 (24-26)	24-26 ft	Wet, very dark gray clay	48.7
GT17-107	GT17- 107 (30-38)	30-38 ft	Moist, very dark gray sandy clay	33.6
GT17-108	GT17- 108 (8-13)	8-13 ft	Wet, very dark brown clay	85.2
GT17-108	GT17- 108 (20-25)	20-25 ft	Moist, very dark gray clayey gravel with sand	18.7

Notes: Temperature of Drying : 110° Celsius



Client: AECOM	Project: North Water Street - MGP	Location: Poughkeepsie, NY	Project No: GTX-306681
Boring ID: GT17-100	Sample Type: jar	Tested By: GA	
Sample ID: GT17-100 (19-21)	Test Date: 07/21/17	Checked By: emm	
Depth: 19-21 ft	Test Id: 416491		
Test Comment: ---			
Visual Description: Moist, very dark gray silty sand with gravel			
Sample Comment: ---			

Particle Size Analysis - ASTM D422

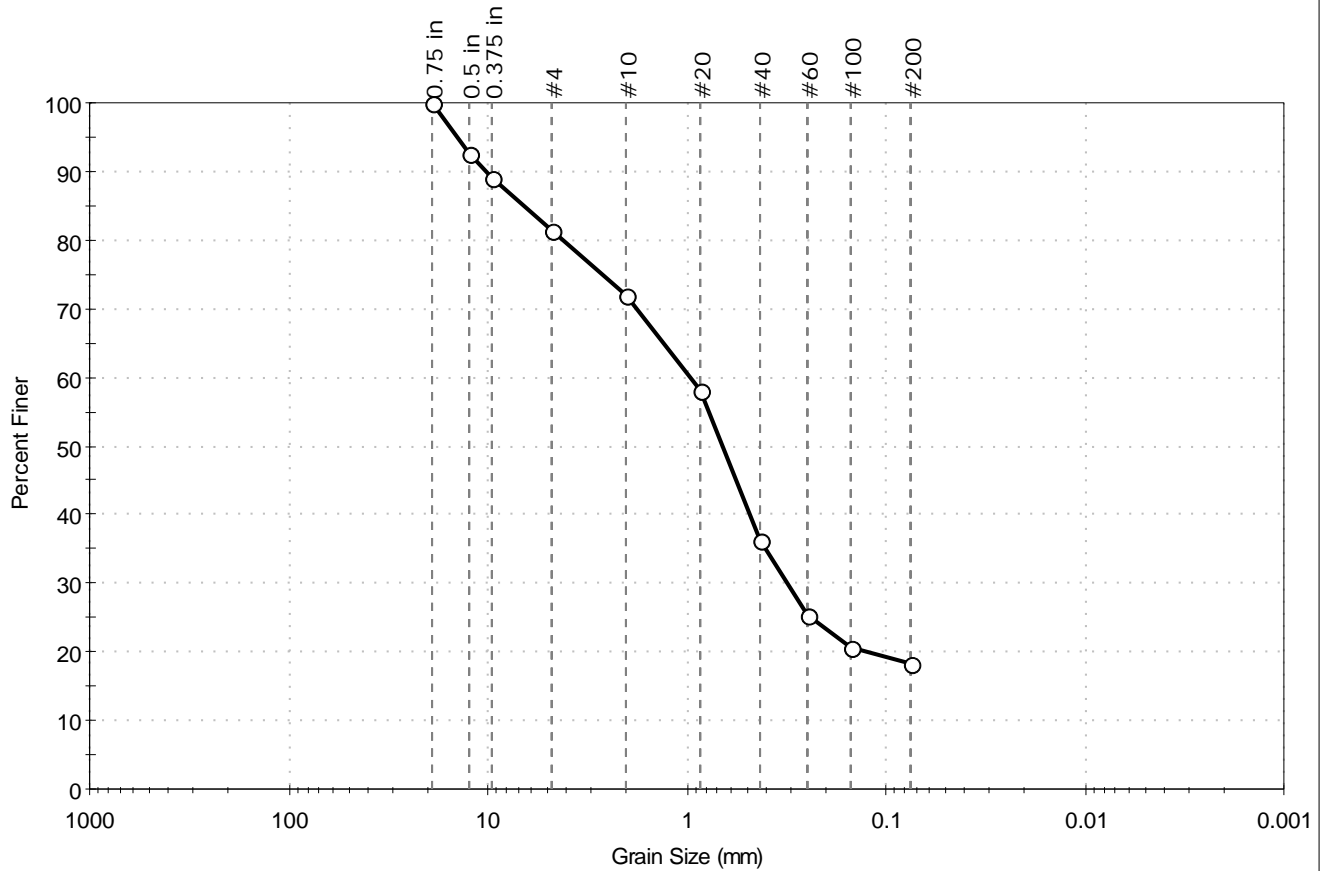

% Cobble	% Gravel	% Sand	% Silt & Clay Size
--	18.5	63.1	18.4

Sieve Name	Sieve Size, mm	Percent Finer	Spec. Percent	Complies
0.75 in	19.00	100		
0.5 in	12.50	93		
0.375 in	9.50	89		
#4	4.75	81		
#10	2.00	72		
#20	0.85	58		
#40	0.42	36		
#60	0.25	25		
#100	0.15	21		
#200	0.075	18		

<u>Coefficients</u>	
D ₈₅ = 6.5302 mm	D ₃₀ = 0.3142 mm
D ₆₀ = 0.9499 mm	D ₁₅ = N/A
D ₅₀ = 0.6555 mm	D ₁₀ = N/A
C _u = N/A	C _c = N/A

<u>Classification</u>	
<u>ASTM</u>	Silty sand with gravel (SM)
<u>AASHTO</u>	Stone Fragments, Gravel and Sand (A-1-b (0))

<u>Sample/Test Description</u>	
Sand/Gravel Particle Shape : ANGULAR	
Sand/Gravel Hardness : HARD	



Client:	AECOM	Project No:	GTX-306681
Project:	North Water Street - MGP	Sample Type:	jar
Location:	Poughkeepsie, NY	Tested By:	GA
Boring ID:	GT17-100	Test Date:	07/21/17
Sample ID:	GT17-100 (27-29)	Checked By:	emm
Depth:	27-29 ft	Test Id:	416492
Test Comment:	---		
Visual Description:	Moist, very dark brown clay		
Sample Comment:	---		

Particle Size Analysis - ASTM D422

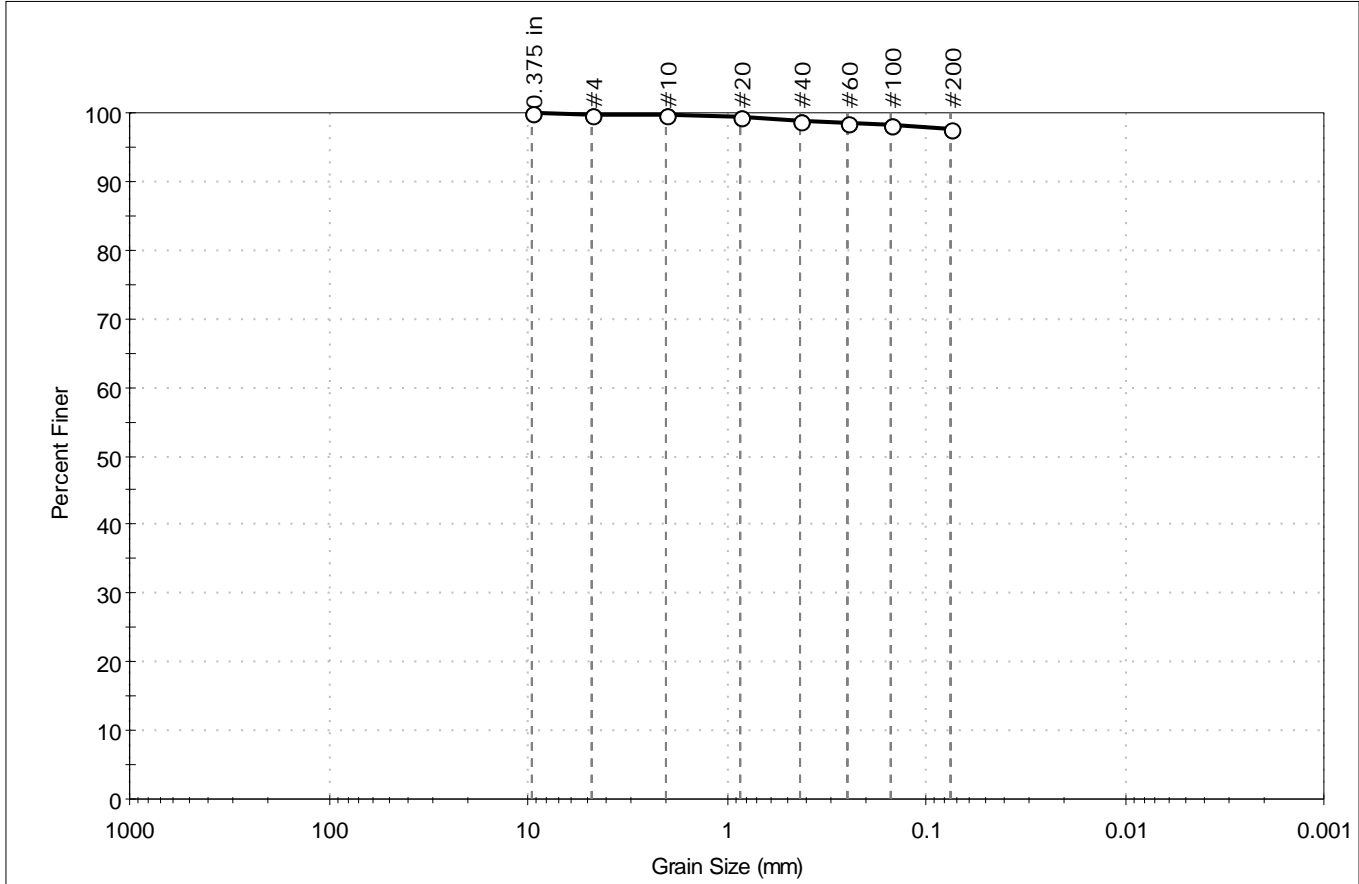

% Cobble	% Gravel	% Sand	% Silt & Clay Size
--	0.2	2.2	97.6

Sieve Name	Sieve Size, mm	Percent Finer	Spec. Percent	Complies
0.375 in	9.50	100		
#4	4.75	100		
#10	2.00	100		
#20	0.85	99		
#40	0.42	99		
#60	0.25	98		
#100	0.15	98		
#200	0.075	98		

<u>Coefficients</u>	
D ₈₅ = N/A	D ₃₀ = N/A
D ₆₀ = N/A	D ₁₅ = N/A
D ₅₀ = N/A	D ₁₀ = N/A
C _u = N/A	C _c = N/A

<u>Classification</u>	
<u>ASTM</u>	Fat clay (CH)
<u>AASHTO</u>	Clayey Soils (A-7-5 (48))

<u>Sample/Test Description</u>	
Sand/Gravel Particle Shape :	---
Sand/Gravel Hardness :	---



Client: AECOM	Project: North Water Street - MGP	Location: Poughkeepsie, NY	Project No: GTX-306681
Boring ID: GT17-101	Sample Type: jar	Tested By: GA	
Sample ID: GT17-101 (15-18)	Test Date: 07/21/17	Checked By: emm	
Depth: 15-18 ft	Test Id: 416493		
Test Comment: ---			
Visual Description: Moist, very dark gray gravel with silt and sand			
Sample Comment: ---			

Particle Size Analysis - ASTM D422

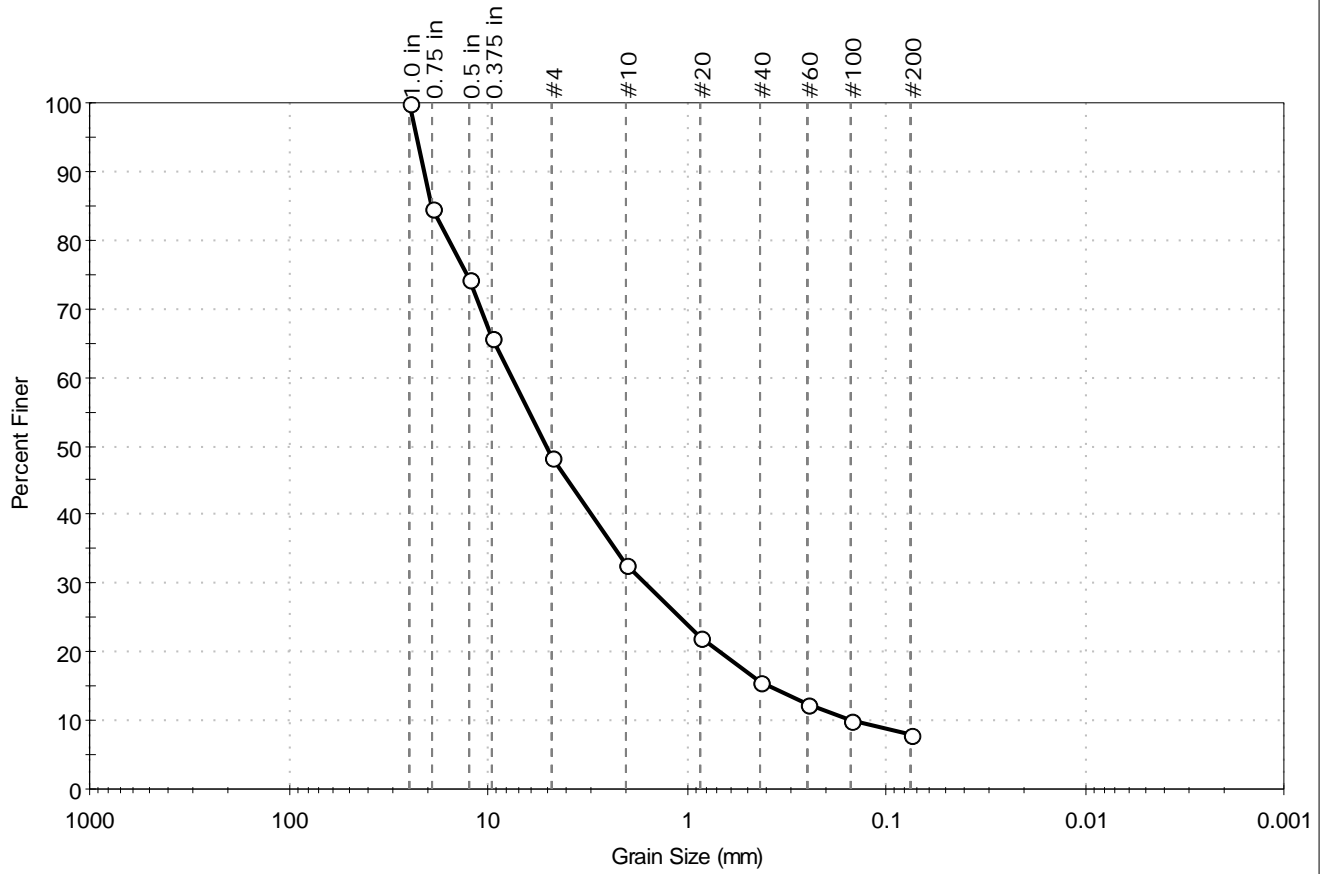

% Cobble	% Gravel	% Sand	% Silt & Clay Size
--	51.6	40.5	7.9

Sieve Name	Sieve Size, mm	Percent Finer	Spec. Percent	Complies
1.0 in	25.00	100		
0.75 in	19.00	85		
0.5 in	12.50	74		
0.375 in	9.50	66		
#4	4.75	48		
#10	2.00	33		
#20	0.85	22		
#40	0.42	16		
#60	0.25	12		
#100	0.15	10		
#200	0.075	7.9		

<u>Coefficients</u>	
D ₈₅ = 19.0911 mm	D ₃₀ = 1.6155 mm
D ₆₀ = 7.5350 mm	D ₁₅ = 0.3901 mm
D ₅₀ = 5.0551 mm	D ₁₀ = 0.1515 mm
C _u = 49.736	C _c = 2.286

<u>Classification</u>	
ASTM	Well-graded gravel with silt and sand (GW-GM)
AASHTO	Stone Fragments, Gravel and Sand (A-1-a (1))

Sample/Test Description
 Sand/Gravel Particle Shape : ANGULAR
 Sand/Gravel Hardness : HARD



Client:	AECOM		
Project:	North Water Street - MGP		
Location:	Poughkeepsie, NY	Project No:	GTX-306681
Boring ID:	GT17-101	Sample Type:	jar
Sample ID:	GT17-101 (27-28)	Test Date:	07/21/17
Depth :	27-28 ft	Test Id:	416494
Test Comment:	---		
Visual Description:	Moist, very dark gray clayey sand with gravel		
Sample Comment:	---		

Particle Size Analysis - ASTM D422

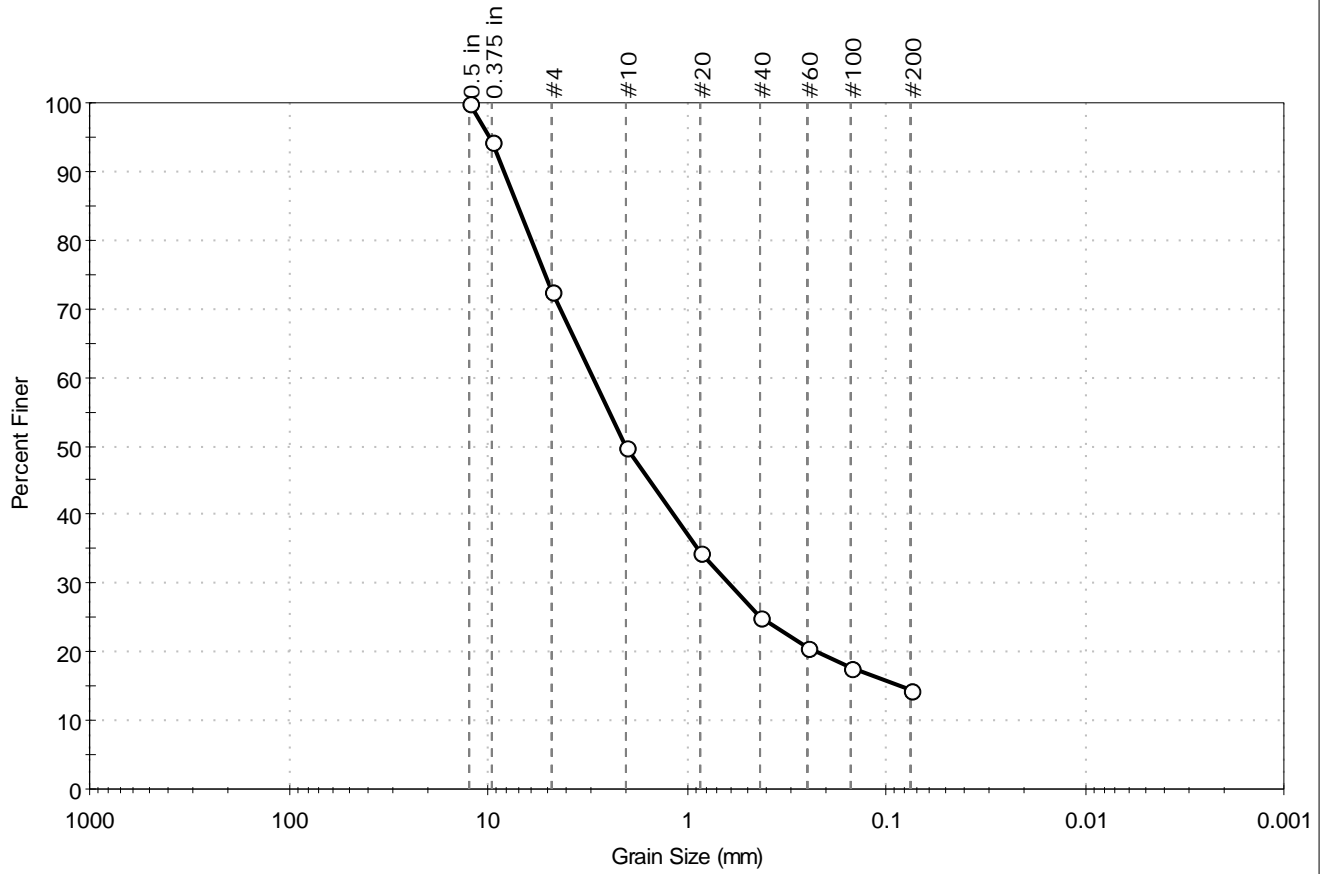

% Cobble	% Gravel	% Sand	% Silt & Clay Size
--	27.4	58.1	14.5

Sieve Name	Sieve Size, mm	Percent Finer	Spec. Percent	Complies
0.5 in	12.50	100		
0.375 in	9.50	95		
#4	4.75	73		
#10	2.00	50		
#20	0.85	35		
#40	0.42	25		
#60	0.25	21		
#100	0.15	18		
#200	0.075	15		

<u>Coefficients</u>	
D ₈₅ = 7.0318 mm	D ₃₀ = 0.6107 mm
D ₆₀ = 2.9460 mm	D ₁₅ = 0.0836 mm
D ₅₀ = 2.0160 mm	D ₁₀ = N/A
C _u = N/A	C _c = N/A

<u>Classification</u>	
<u>ASTM</u>	Clayey sand with gravel (SC)
<u>AASHTO</u>	Clayey Gravel and Sand (A-2-6 (0))

<u>Sample/Test Description</u>
Sand/Gravel Particle Shape : ANGULAR
Sand/Gravel Hardness : HARD



Client:	AECOM		
Project:	North Water Street - MGP		
Location:	Poughkeepsie, NY	Project No:	GTX-306681
Boring ID:	GT17-102	Sample Type:	jar
Sample ID:	GT17-102 (11-14)	Test Date:	07/21/17
Depth :	11-14 ft	Test Id:	416495
Test Comment:	---		
Visual Description:	Moist, dark olive gray gravel with silt and sand		
Sample Comment:	---		

Particle Size Analysis - ASTM D422

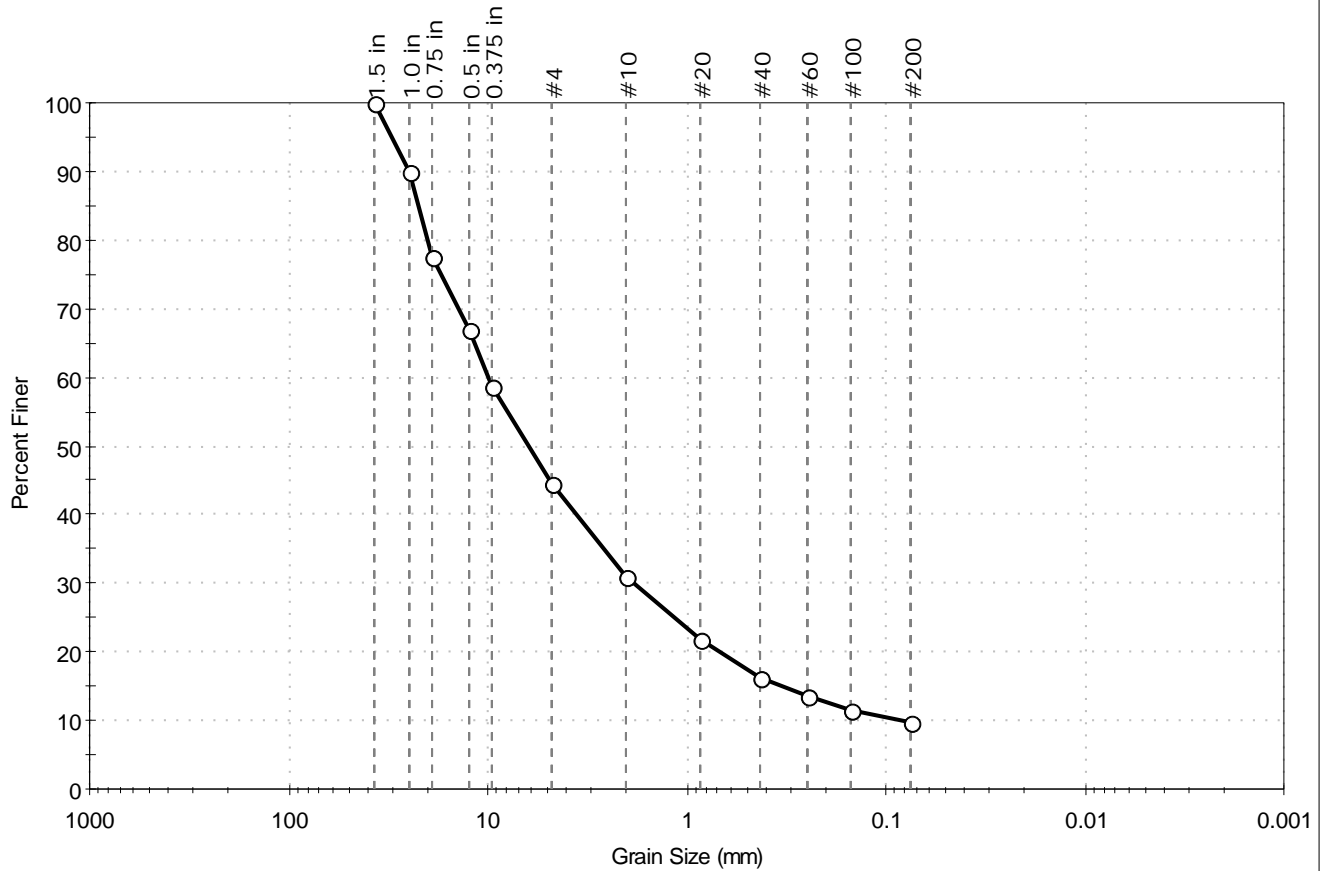

% Cobble	% Gravel	% Sand	% Silt & Clay Size
--	55.3	34.9	9.8

Sieve Name	Sieve Size, mm	Percent Finer	Spec. Percent	Complies
1.5 in	37.50	100		
1.0 in	25.00	90		
0.75 in	19.00	78		
0.5 in	12.50	67		
0.375 in	9.50	59		
#4	4.75	45		
#10	2.00	31		
#20	0.85	22		
#40	0.42	16		
#60	0.25	14		
#100	0.15	11		
#200	0.075	9.8		

<u>Coefficients</u>	
D ₈₅ = 22.4160 mm	D ₃₀ = 1.8085 mm
D ₆₀ = 9.8949 mm	D ₁₅ = 0.3281 mm
D ₅₀ = 6.1732 mm	D ₁₀ = 0.0829 mm
C _u = 119.359	C _c = 3.987

<u>Classification</u>	
<u>ASTM</u>	Poorly graded gravel with silt and sand (GP-GM)
<u>AASHTO</u>	Stone Fragments, Gravel and Sand (A-1-a (1))

<u>Sample/Test Description</u>	
Sand/Gravel Particle Shape : ANGULAR	
Sand/Gravel Hardness : HARD	



Client: AECOM	Project: North Water Street - MGP		Project No: GTX-306681
Location: Poughkeepsie, NY	Boring ID: GT17-102	Sample Type: jar	Tested By: GA
Sample ID: GT17-102 (17-18)	Test Date: 07/21/17	Checked By: emm	
Depth: 17-18 ft	Test Id: 416496		
Test Comment: ---	Visual Description: Moist, very dark brown silt		
Sample Comment: ---			

Particle Size Analysis - ASTM D422

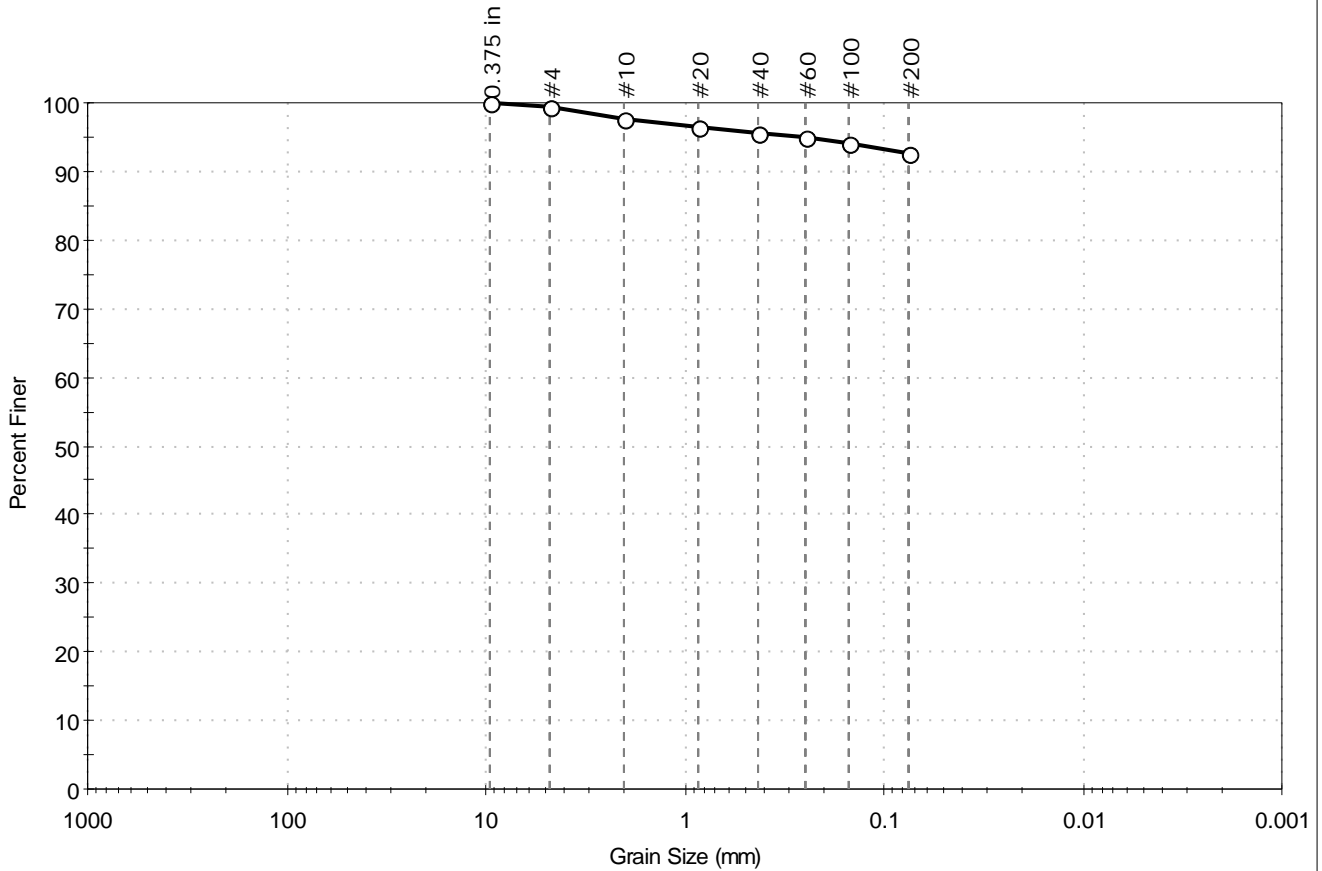

% Cobble	% Gravel	% Sand	% Silt & Clay Size
---	0.5	6.9	92.6

Sieve Name	Sieve Size, mm	Percent Finer	Spec. Percent	Complies
0.375 in	9.50	100		
#4	4.75	99		
#10	2.00	98		
#20	0.85	97		
#40	0.42	96		
#60	0.25	95		
#100	0.15	94		
#200	0.075	93		

<u>Coefficients</u>	
D ₈₅ = N/A	D ₃₀ = N/A
D ₆₀ = N/A	D ₁₅ = N/A
D ₅₀ = N/A	D ₁₀ = N/A
C _u = N/A	C _c = N/A

<u>Classification</u>	
<u>ASTM</u>	Elastic silt (MH)
<u>AASHTO</u>	Clayey Soils (A-7-5 (39))

<u>Sample/Test Description</u>
Sand/Gravel Particle Shape : ---
Sand/Gravel Hardness : ---



Client: AECOM	Project: North Water Street - MGP	Location: Poughkeepsie, NY	Project No: GTX-306681
Boring ID: GT17-103	Sample Type: jar	Tested By: GA	
Sample ID: GT17-103 (12-15)	Test Date: 07/21/17	Checked By: emm	
Depth: 12-15 ft	Test Id: 416497		
Test Comment: ---			
Visual Description: Moist, very dark gray sandy silt with gravel			
Sample Comment: ---			

Particle Size Analysis - ASTM D422

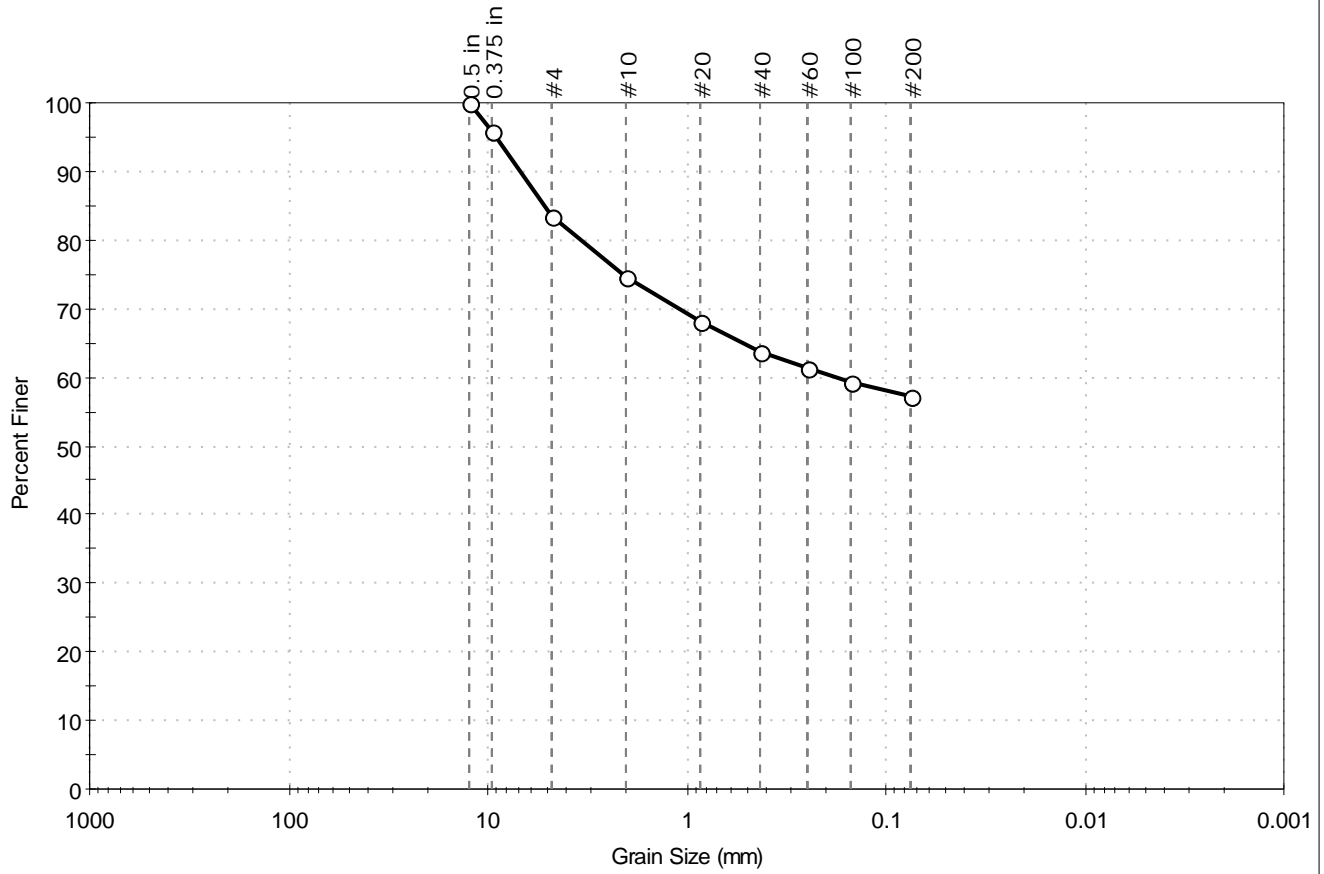

% Cobble	% Gravel	% Sand	% Silt & Clay Size
--	16.6	26.1	57.3

Sieve Name	Sieve Size, mm	Percent Finer	Spec. Percent	Complies
0.5 in	12.50	100		
0.375 in	9.50	96		
#4	4.75	83		
#10	2.00	75		
#20	0.85	68		
#40	0.42	64		
#60	0.25	61		
#100	0.15	59		
#200	0.075	57		

<u>Coefficients</u>	
D ₈₅ = 5.2029 mm	D ₃₀ = N/A
D ₆₀ = 0.1738 mm	D ₁₅ = N/A
D ₅₀ = N/A	D ₁₀ = N/A
C _u = N/A	C _c = N/A

<u>Classification</u>	
<u>ASTM</u>	Sandy Elastic silt with gravel (MH)
<u>AASHTO</u>	Clayey Soils (A-7-5 (17))

<u>Sample/Test Description</u>	
Sand/Gravel Particle Shape : ANGULAR	
Sand/Gravel Hardness : HARD	



Client:	AECOM		
Project:	North Water Street - MGP		
Location:	Poughkeepsie, NY	Project No:	GTX-306681
Boring ID:	GT17-103	Sample Type:	jar
Sample ID:	GT17-103 (16-19)	Test Date:	07/21/17
Depth :	16-19 ft	Test Id:	416498
Test Comment:	---		
Visual Description:	Moist, very dark gray clayey gravel with sand		
Sample Comment:	---		

Particle Size Analysis - ASTM D422

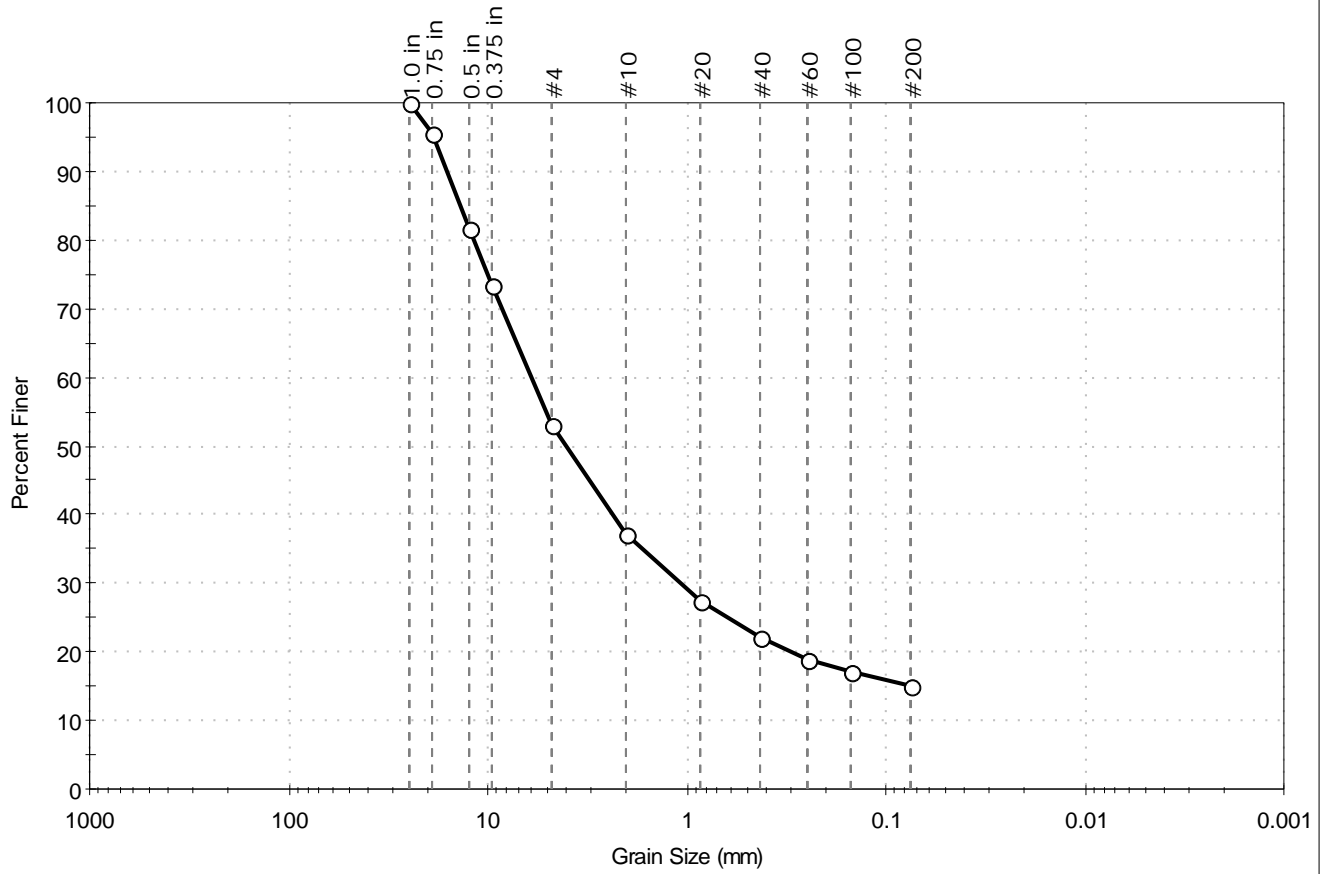

% Cobble	% Gravel	% Sand	% Silt & Clay Size
--	47.0	38.0	15.0

Sieve Name	Sieve Size, mm	Percent Finer	Spec. Percent	Complies
1.0 in	25.00	100		
0.75 in	19.00	96		
0.5 in	12.50	82		
0.375 in	9.50	73		
#4	4.75	53		
#10	2.00	37		
#20	0.85	28		
#40	0.42	22		
#60	0.25	19		
#100	0.15	17		
#200	0.075	15		

<u>Coefficients</u>	
D ₈₅ = 13.7611 mm	D ₃₀ = 1.0555 mm
D ₆₀ = 6.0253 mm	D ₁₅ = 0.0750 mm
D ₅₀ = 4.0245 mm	D ₁₀ = N/A
C _u = N/A	C _c = N/A

<u>Classification</u>	
<u>ASTM</u>	Clayey gravel with sand (GC)
<u>AASHTO</u>	Clayey Gravel and Sand (A-2-7 (0))

<u>Sample/Test Description</u>
Sand/Gravel Particle Shape : ANGULAR
Sand/Gravel Hardness : HARD



Client: AECOM	Project: North Water Street - MGP	Location: Poughkeepsie, NY	Project No: GTX-306681
Boring ID: GT17-104	Sample Type: jar	Tested By: GA	Checked By: emm
Sample ID: GT17-104 (13-15)	Test Date: 07/21/17	Test Id: 416499	
Depth: 13-15 ft			
Test Comment: ---	Visual Description: Moist, very dark brown silt	Sample Comment: ---	

Particle Size Analysis - ASTM D422

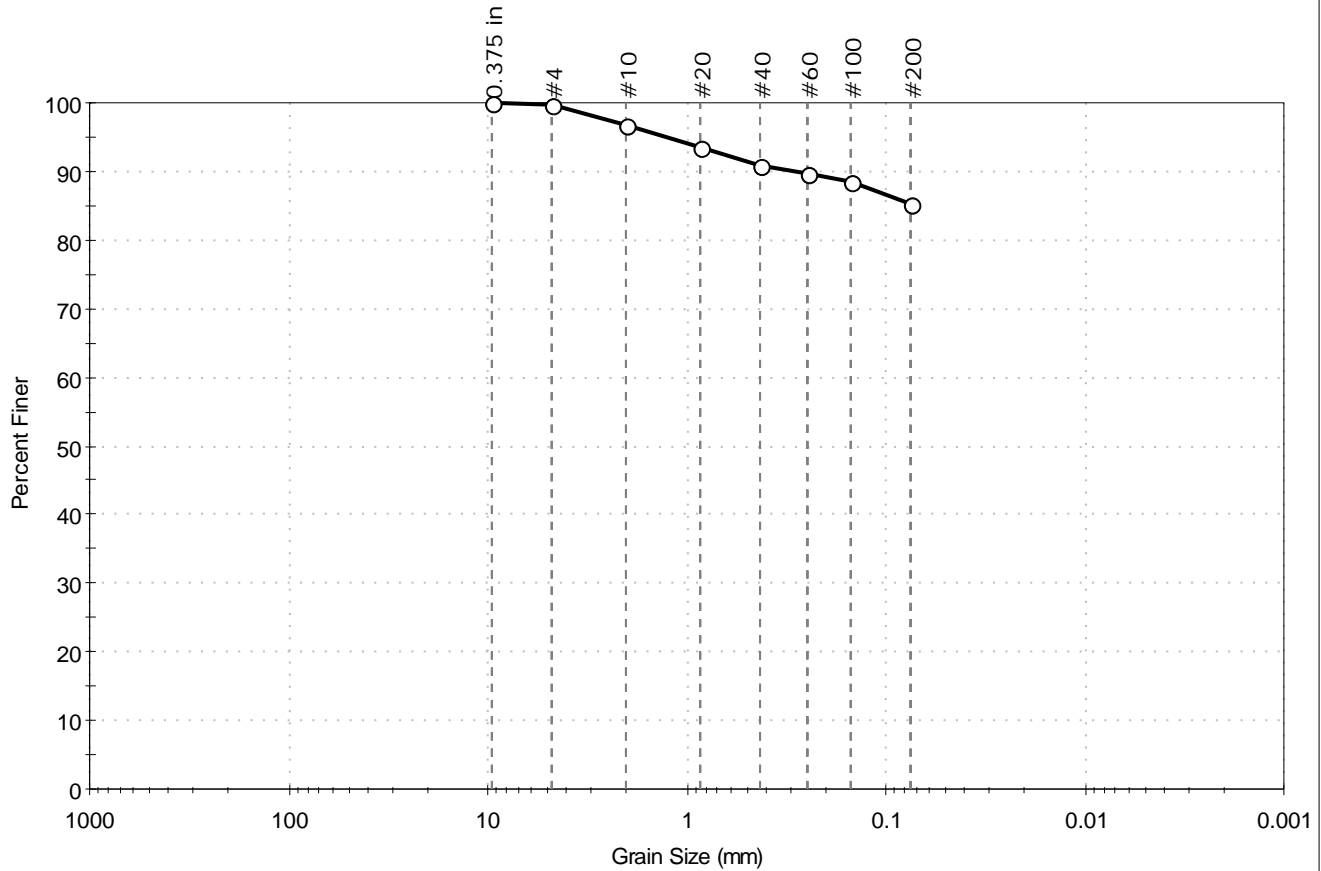

% Cobble	% Gravel	% Sand	% Silt & Clay Size
---	0.4	14.4	85.2

Sieve Name	Sieve Size, mm	Percent Finer	Spec. Percent	Complies
0.375 in	9.50	100		
#4	4.75	100		
#10	2.00	97		
#20	0.85	93		
#40	0.42	91		
#60	0.25	90		
#100	0.15	89		
#200	0.075	85		

<u>Coefficients</u>	
D ₈₅ = N/A	D ₃₀ = N/A
D ₆₀ = N/A	D ₁₅ = N/A
D ₅₀ = N/A	D ₁₀ = N/A
C _u = N/A	C _c = N/A

<u>Classification</u>	
<u>ASTM</u>	Elastic silt (MH)
<u>AASHTO</u>	Clayey Soils (A-7-5 (22))

<u>Sample/Test Description</u>
Sand/Gravel Particle Shape : ---
Sand/Gravel Hardness : ---



Client:	AECOM		Project No:	GTX-306681	
Project:	North Water Street - MGP		Boring ID:	GT17-104	
Location:	Poughkeepsie, NY		Sample Type:	jar	
Tested By:	GA		Sample ID:	GT17-104 (17-19)	
Checked By:	emm		Test Date:	07/21/17	
Test Id:	416500		Depth :	17-19 ft	
Test Comment:	---				
Visual Description:	Moist, very dark gray clayey gravel with sand				
Sample Comment:	---				

Particle Size Analysis - ASTM D422

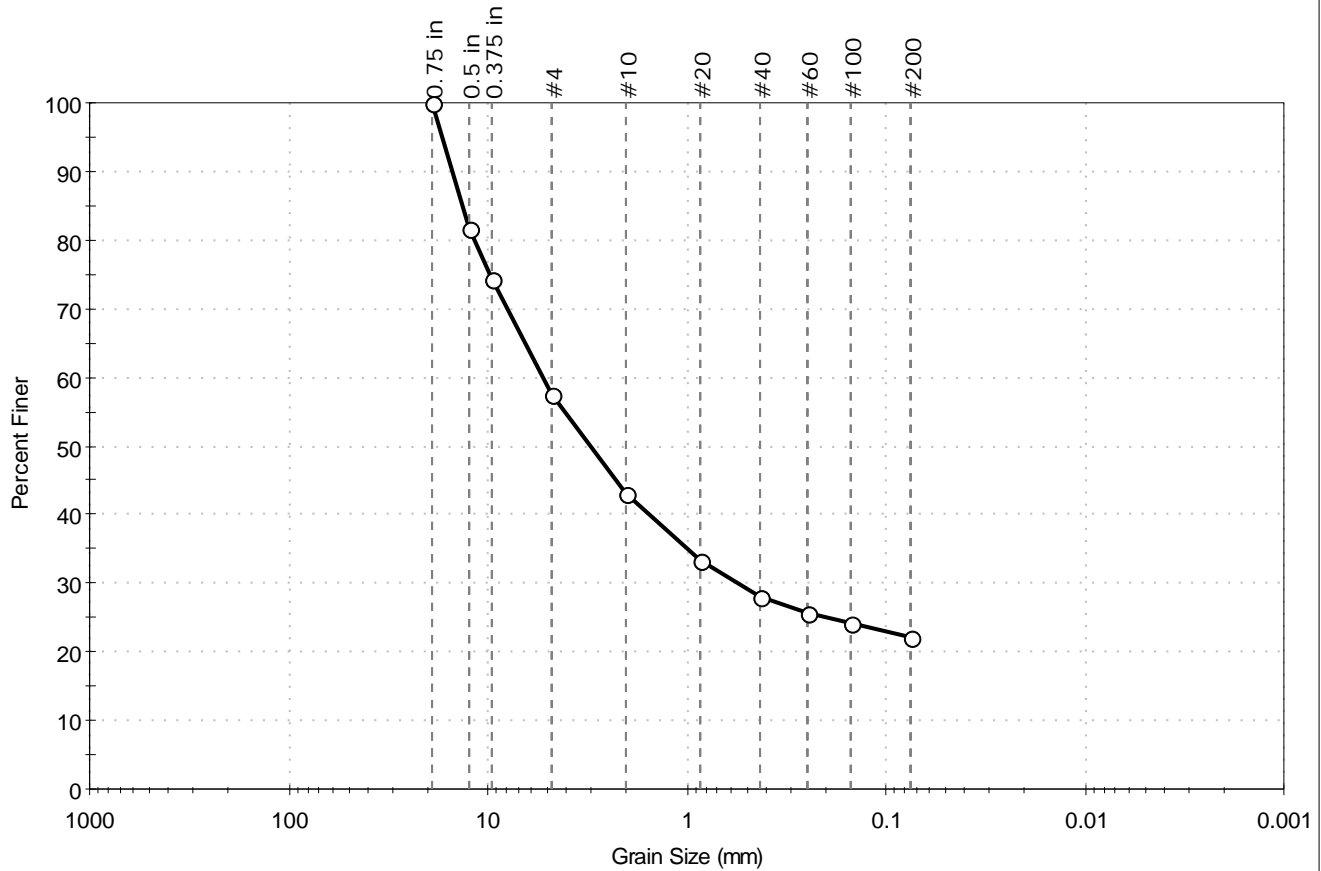

% Cobble	% Gravel	% Sand	% Silt & Clay Size
--	42.5	35.4	22.1

Sieve Name	Sieve Size, mm	Percent Finer	Spec. Percent	Complies
0.75 in	19.00	100		
0.5 in	12.50	82		
0.375 in	9.50	74		
#4	4.75	57		
#10	2.00	43		
#20	0.85	33		
#40	0.42	28		
#60	0.25	26		
#100	0.15	24		
#200	0.075	22		

<u>Coefficients</u>	
D ₈₅ = 13.5025 mm	D ₃₀ = 0.5472 mm
D ₆₀ = 5.2752 mm	D ₁₅ = N/A
D ₅₀ = 3.0361 mm	D ₁₀ = N/A
C _u = N/A	C _c = N/A

<u>Classification</u>	
<u>ASTM</u>	Clayey gravel with sand (GC)
<u>AASHTO</u>	Clayey Gravel and Sand (A-2-6 (0))

<u>Sample/Test Description</u>
Sand/Gravel Particle Shape : ANGULAR
Sand/Gravel Hardness : HARD



Client:	AECOM		
Project:	North Water Street - MGP		
Location:	Poughkeepsie, NY	Project No:	GTX-306681
Boring ID:	GT17-105	Sample Type:	jar
Sample ID:	GT17-105 (6-8)	Test Date:	07/21/17
Depth :	6-8 ft	Test Id:	416501
Test Comment:	---		
Visual Description:	Moist, very dark gray gravel with silt and sand		
Sample Comment:	---		

Particle Size Analysis - ASTM D422

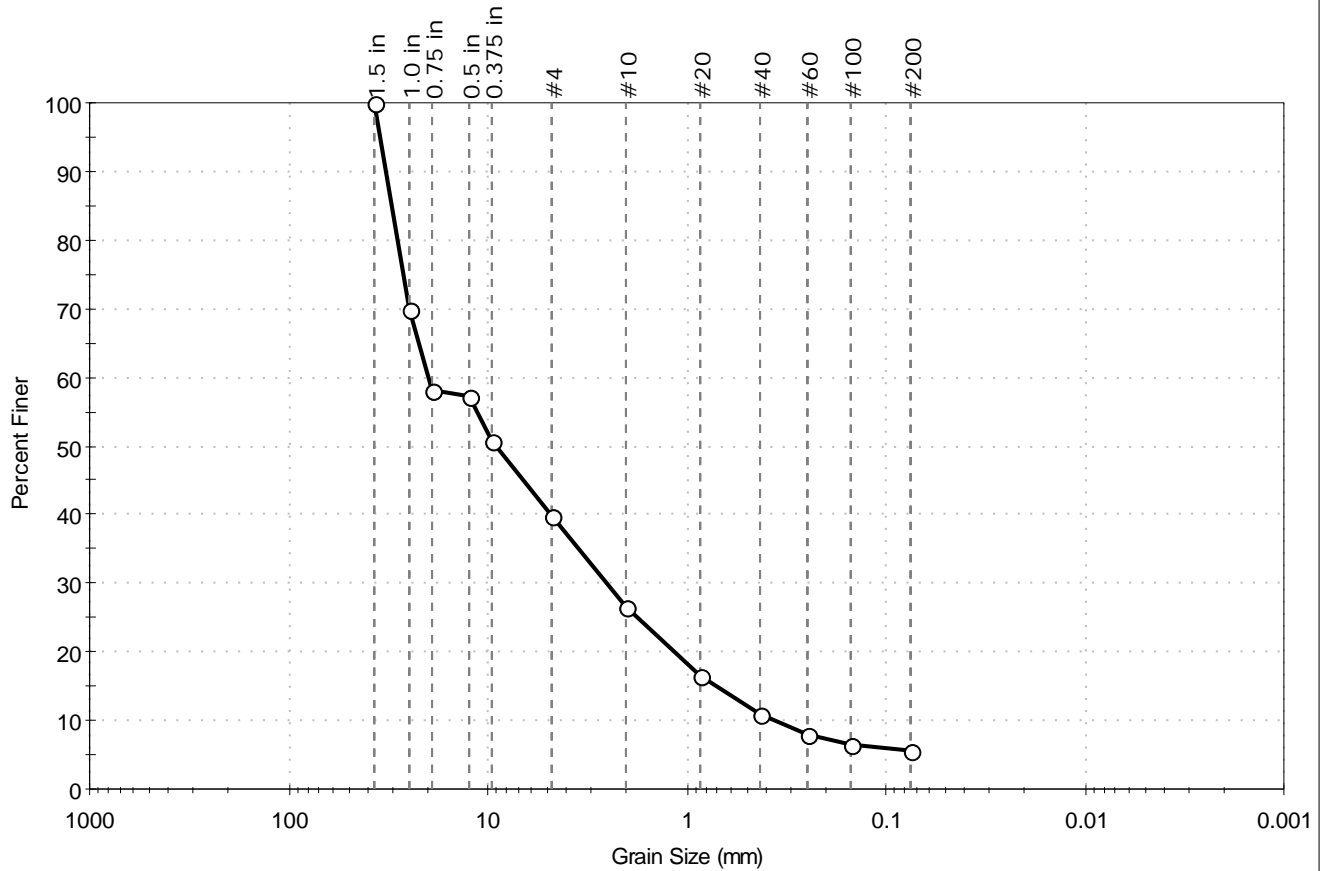

% Cobble	% Gravel	% Sand	% Silt & Clay Size
--	60.3	34.1	5.6

Sieve Name	Sieve Size, mm	Percent Finer	Spec. Percent	Complies
1.5 in	37.50	100		
1.0 in	25.00	70		
0.75 in	19.00	58		
0.5 in	12.50	57		
0.375 in	9.50	51		
#4	4.75	40		
#10	2.00	26		
#20	0.85	16		
#40	0.42	11		
#60	0.25	8		
#100	0.15	7		
#200	0.075	5.6		

<u>Coefficients</u>	
D ₈₅ = 30.6332 mm	D ₃₀ = 2.5218 mm
D ₆₀ = 19.8299 mm	D ₁₅ = 0.7045 mm
D ₅₀ = 9.0744 mm	D ₁₀ = 0.3550 mm
C _u = 55.859	C _c = 0.903

<u>Classification</u>	
ASTM	Poorly graded gravel with silt and sand (GP-GM)
AASHTO	Stone Fragments, Gravel and Sand (A-1-a (1))

<u>Sample/Test Description</u>	
Sand/Gravel Particle Shape : ANGULAR	
Sand/Gravel Hardness : HARD	



Client:	AECOM		Project No:	GTX-306681	
Project:	North Water Street - MGP		Boring ID:	GT17-105	
Location:	Poughkeepsie, NY		Sample Type:	jar	
Tested By:	GA		Sample ID:	GT17-105 (10-14)	
Checked By:	emm		Test Date:	07/21/17	
Test Id:	416502		Depth :	10-14 ft	
Test Comment:	---				
Visual Description:	Moist, very dark gray sand with gravel				
Sample Comment:	---				

Particle Size Analysis - ASTM D422

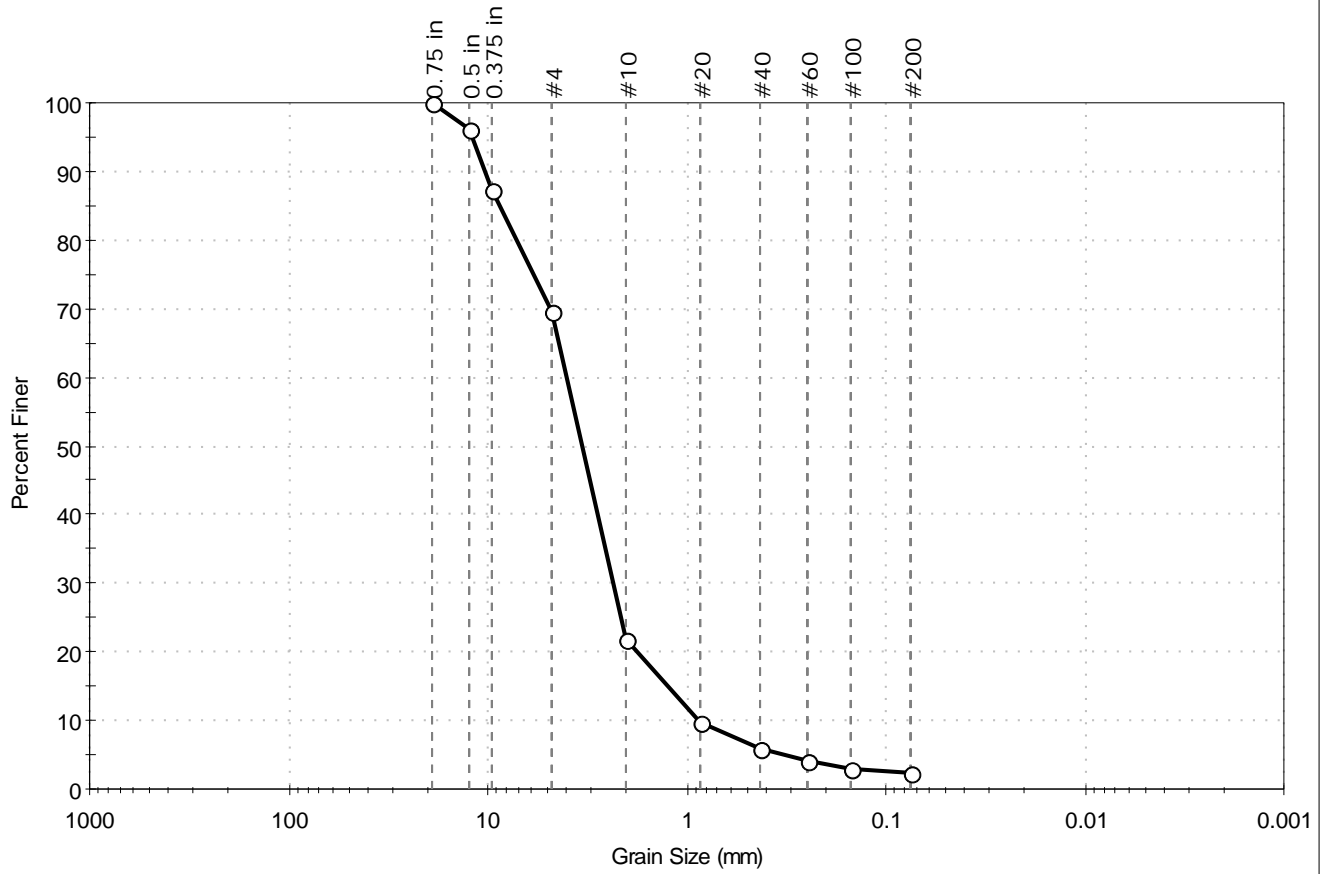

% Cobble	% Gravel	% Sand	% Silt & Clay Size
--	30.3	67.3	2.4

Sieve Name	Sieve Size, mm	Percent Finer	Spec. Percent	Complies
0.75 in	19.00	100		
0.5 in	12.50	96		
0.375 in	9.50	87		
#4	4.75	70		
#10	2.00	22		
#20	0.85	10		
#40	0.42	6		
#60	0.25	4		
#100	0.15	3		
#200	0.075	2.4		

<u>Coefficients</u>	
D ₈₅ = 8.6905 mm	D ₃₀ = 2.3167 mm
D ₆₀ = 3.9856 mm	D ₁₅ = 1.2289 mm
D ₅₀ = 3.3262 mm	D ₁₀ = 0.8623 mm
C _u = 4.622	C _c = 1.562

<u>Classification</u>	
<u>ASTM</u>	Poorly graded sand with gravel (SP)
<u>AASHTO</u>	Stone Fragments, Gravel and Sand (A-1-a (1))

<u>Sample/Test Description</u>	
Sand/Gravel Particle Shape : ANGULAR	
Sand/Gravel Hardness : HARD	



Client: AECOM	Project: North Water Street - MGP	Location: Poughkeepsie, NY	Project No: GTX-306681
Boring ID: GT17-105	Sample Type: jar	Tested By: GA	
Sample ID: GT17-105 (17-20)	Test Date: 07/21/17	Checked By: emm	
Depth: 17-20 ft	Test Id: 416503		
Test Comment: ---			
Visual Description: Wet, very dark gray clay			
Sample Comment: ---			

Particle Size Analysis - ASTM D422

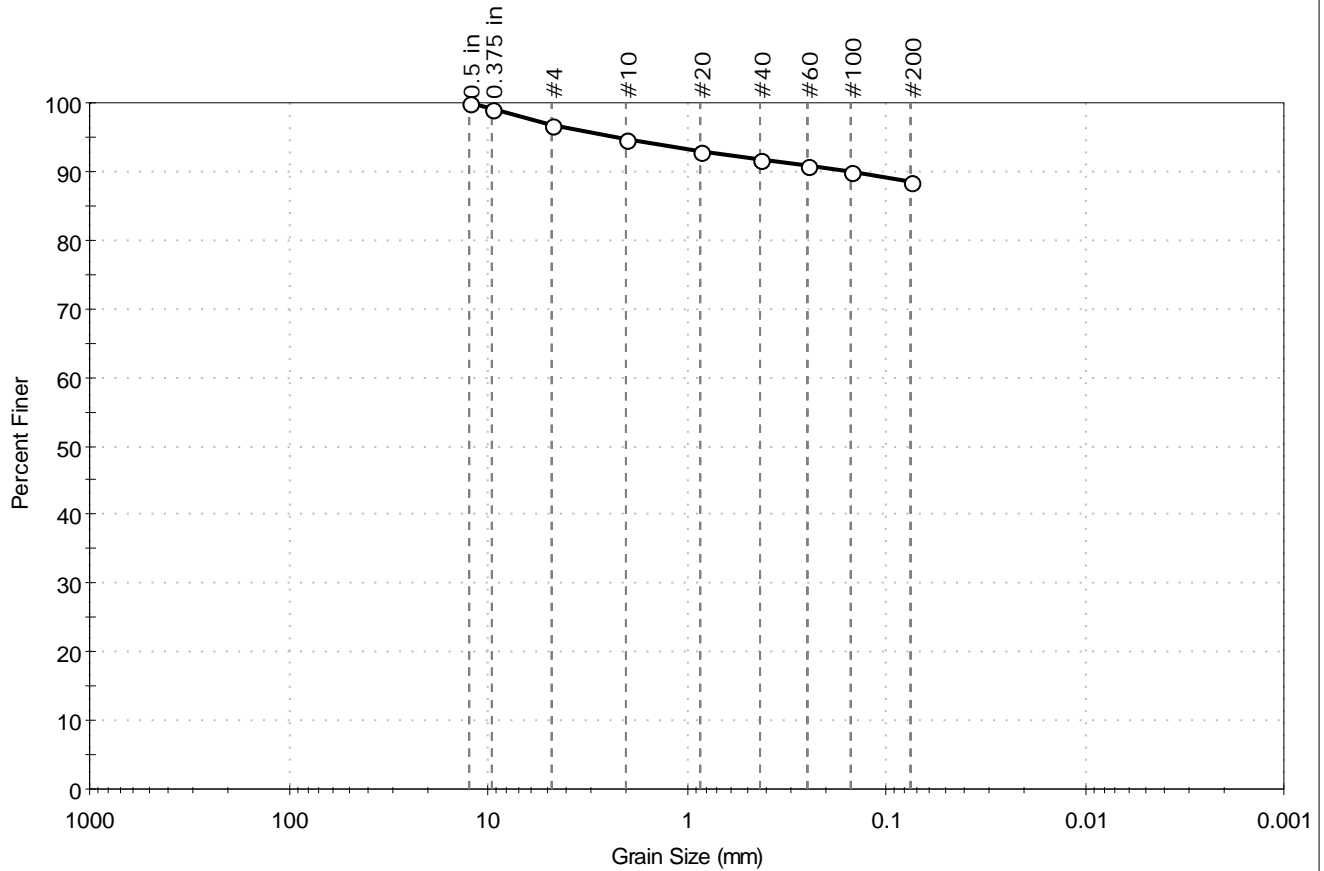

% Cobble	% Gravel	% Sand	% Silt & Clay Size
---	3.3	8.2	88.5

Sieve Name	Sieve Size, mm	Percent Finer	Spec. Percent	Complies
0.5 in	12.50	100		
0.375 in	9.50	99		
#4	4.75	97		
#10	2.00	95		
#20	0.85	93		
#40	0.42	92		
#60	0.25	91		
#100	0.15	90		
#200	0.075	88		

<u>Coefficients</u>	
D ₈₅ = N/A	D ₃₀ = N/A
D ₆₀ = N/A	D ₁₅ = N/A
D ₅₀ = N/A	D ₁₀ = N/A
C _u = N/A	C _c = N/A

<u>Classification</u>	
<u>ASTM</u>	Fat clay (CH)
<u>AASHTO</u>	Clayey Soils (A-7-6 (24))

<u>Sample/Test Description</u>
Sand/Gravel Particle Shape : ---
Sand/Gravel Hardness : ---



Client: AECOM	Project: North Water Street - MGP	Location: Poughkeepsie, NY	Project No: GTX-306681
Boring ID: GT17-106	Sample Type: jar	Tested By: GA	
Sample ID: GT17-106 (10-14)	Test Date: 07/21/17	Checked By: emm	
Depth: 10-14ft	Test Id: 416504		
Test Comment: ---			
Visual Description: Moist, very dark gray gravelly silt			
Sample Comment: ---			

Particle Size Analysis - ASTM D422

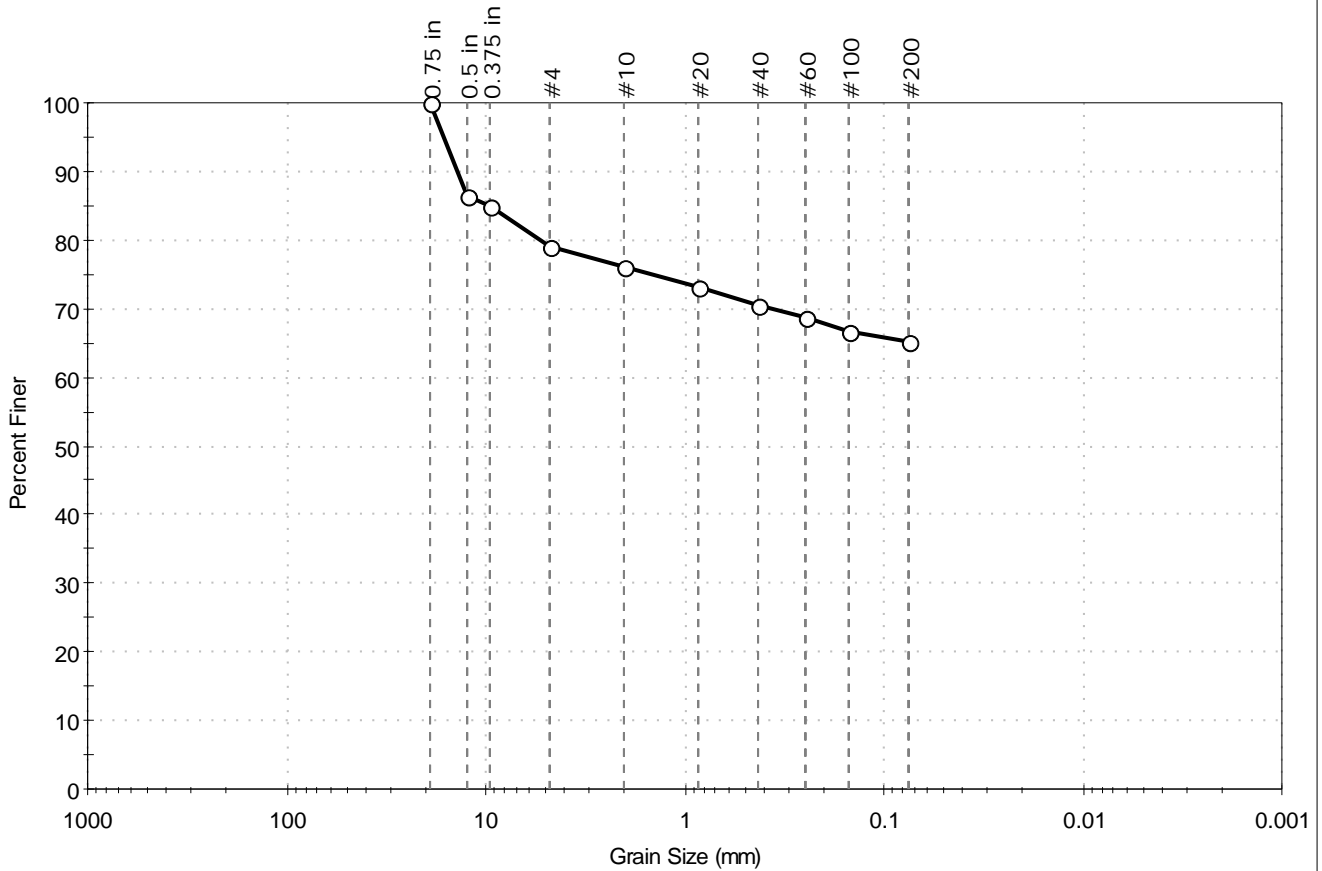

% Cobble	% Gravel	% Sand	% Silt & Clay Size
--	21.0	14.0	65.0

Sieve Name	Sieve Size, mm	Percent Finer	Spec. Percent	Complies
0.75 in	19.00	100		
0.5 in	12.50	87		
0.375 in	9.50	85		
#4	4.75	79		
#10	2.00	76		
#20	0.85	73		
#40	0.42	71		
#60	0.25	69		
#100	0.15	67		
#200	0.075	65		

<u>Coefficients</u>	
D ₈₅ = 9.3976 mm	D ₃₀ = N/A
D ₆₀ = N/A	D ₁₅ = N/A
D ₅₀ = N/A	D ₁₀ = N/A
C _u = N/A	C _c = N/A

<u>Classification</u>	
<u>ASTM</u>	Gravelly Elastic silt (MH)
<u>AASHTO</u>	Clayey Soils (A-7-5 (22))

<u>Sample/Test Description</u>	
Sand/Gravel Particle Shape : ANGULAR	
Sand/Gravel Hardness : HARD	



Client:	AECOM		
Project:	North Water Street - MGP		
Location:	Poughkeepsie, NY	Project No:	GTX-306681
Boring ID:	GT17-106	Sample Type:	jar
Sample ID:	GT17-106 (18-23)	Test Date:	07/21/17
Depth :	18-23 ft	Test Id:	416505
Test Comment:	---		
Visual Description:	Moist, very dark gray and pale yellow gravel with sand		
Sample Comment:	---		

Particle Size Analysis - ASTM D422

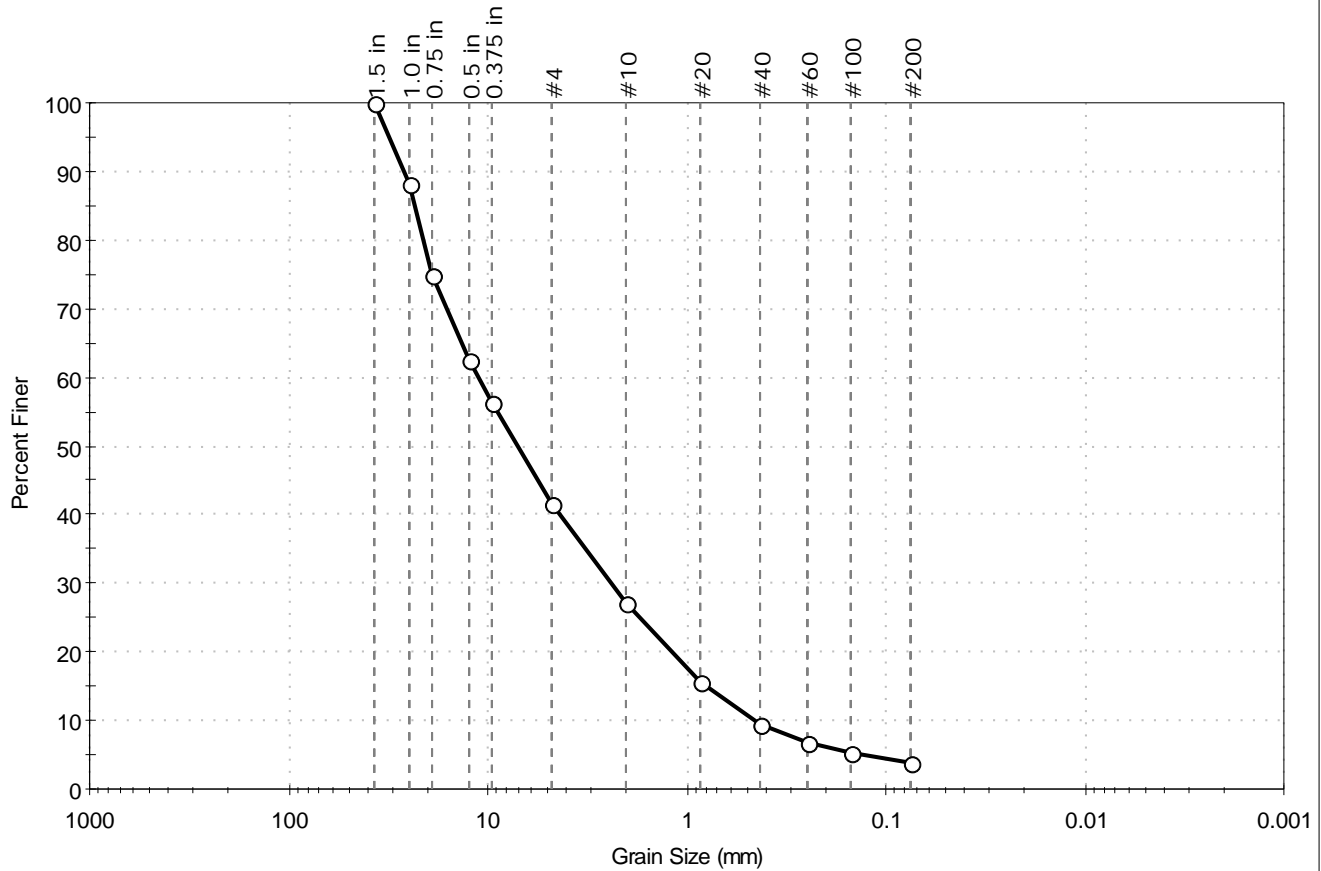

% Cobble	% Gravel	% Sand	% Silt & Clay Size
--	58.4	37.7	3.9

Sieve Name	Sieve Size, mm	Percent Finer	Spec. Percent	Complies
1.5 in	37.50	100		
1.0 in	25.00	88		
0.75 in	19.00	75		
0.5 in	12.50	62		
0.375 in	9.50	56		
#4	4.75	42		
#10	2.00	27		
#20	0.85	16		
#40	0.42	10		
#60	0.25	7		
#100	0.15	5		
#200	0.075	3.9		

<u>Coefficients</u>	
D ₈₅ = 23.3616 mm	D ₃₀ = 2.3879 mm
D ₆₀ = 11.1943 mm	D ₁₅ = 0.7861 mm
D ₅₀ = 7.0564 mm	D ₁₀ = 0.4470 mm
C _u = 25.043	C _c = 1.140

<u>Classification</u>	
<u>ASTM</u>	Well-graded gravel with sand (GW)
<u>AASHTO</u>	Stone Fragments, Gravel and Sand (A-1-a (1))

<u>Sample/Test Description</u>	
Sand/Gravel Particle Shape : ANGULAR	
Sand/Gravel Hardness : HARD	



Client: AECOM	Project: North Water Street - MGP	Project No: GTX-306681
Location: Poughkeepsie, NY	Boring ID: GT17-106	Sample Type: jar
Sample ID: GT17-106 (24-26)	Test Date: 07/21/17	Tested By: GA
Depth: 24-26 ft	Test Id: 416506	Checked By: emm
Test Comment: ---	Visual Description: Wet, very dark gray clay	Sample Comment: ---

Particle Size Analysis - ASTM D422

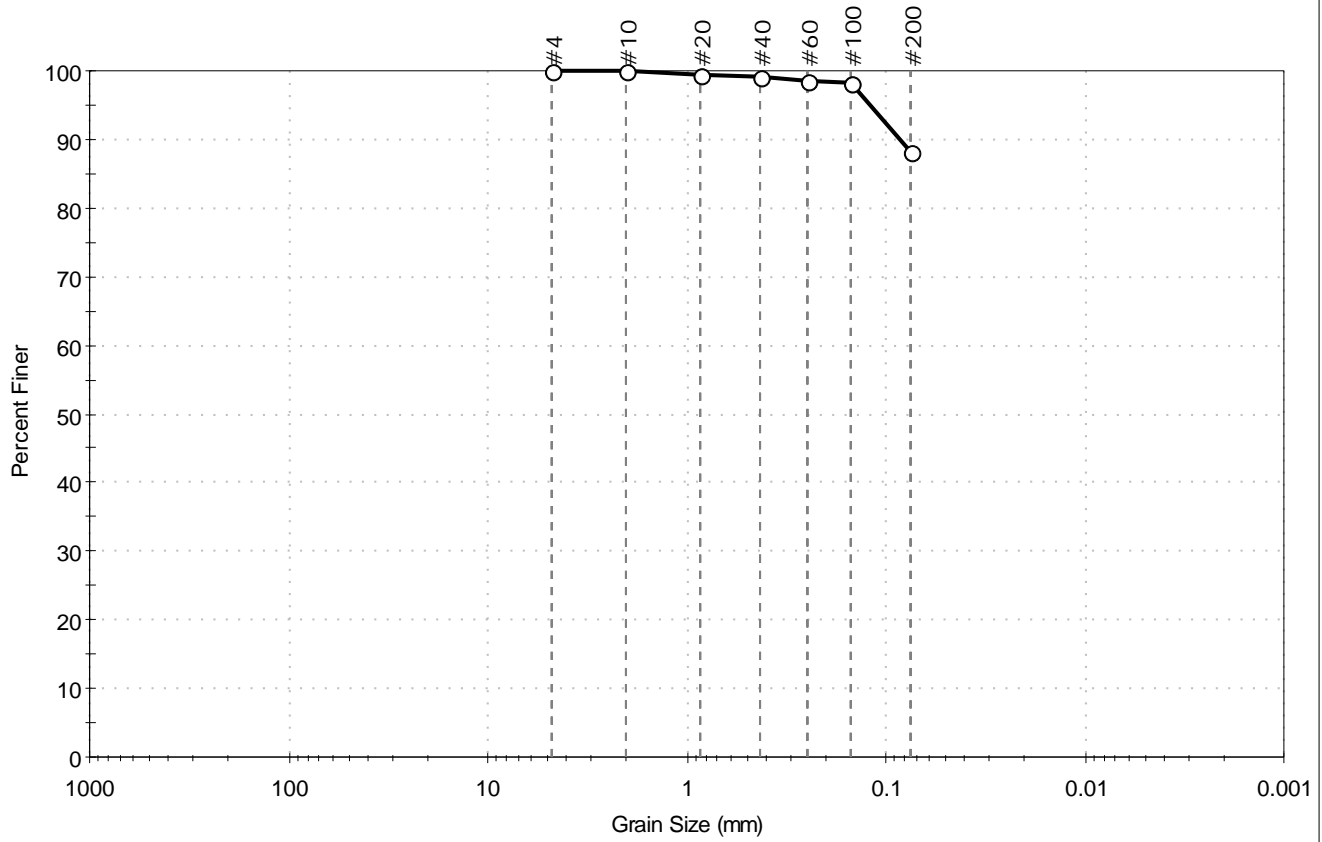

% Cobble	% Gravel	% Sand	% Silt & Clay Size
--	0.0	11.9	88.1

Sieve Name	Sieve Size, mm	Percent Finer	Spec. Percent	Complies
#4	4.75	100		
#10	2.00	100		
#20	0.85	100		
#40	0.42	99		
#60	0.25	99		
#100	0.15	98		
#200	0.075	88		

<u>Coefficients</u>	
D ₈₅ = N/A	D ₃₀ = N/A
D ₆₀ = N/A	D ₁₅ = N/A
D ₅₀ = N/A	D ₁₀ = N/A
C _u = N/A	C _c = N/A

<u>Classification</u>	
<u>ASTM</u>	Lean clay (CL)
<u>AASHTO</u>	Clayey Soils (A-6 (15))

<u>Sample/Test Description</u>
Sand/Gravel Particle Shape : ---
Sand/Gravel Hardness : ---



Client: AECOM	Project: North Water Street - MGP	Project No: GTX-306681
Location: Poughkeepsie, NY	Boring ID: GT17-107	Sample Type: jar
Sample ID: GT17-107 (30-38)	Test Date: 07/21/17	Tested By: GA
Depth: 30-38 ft	Test Id: 416507	Checked By: emm
Test Comment: ---	Visual Description: Moist, very dark gray sandy clay	Sample Comment: ---

Particle Size Analysis - ASTM D422

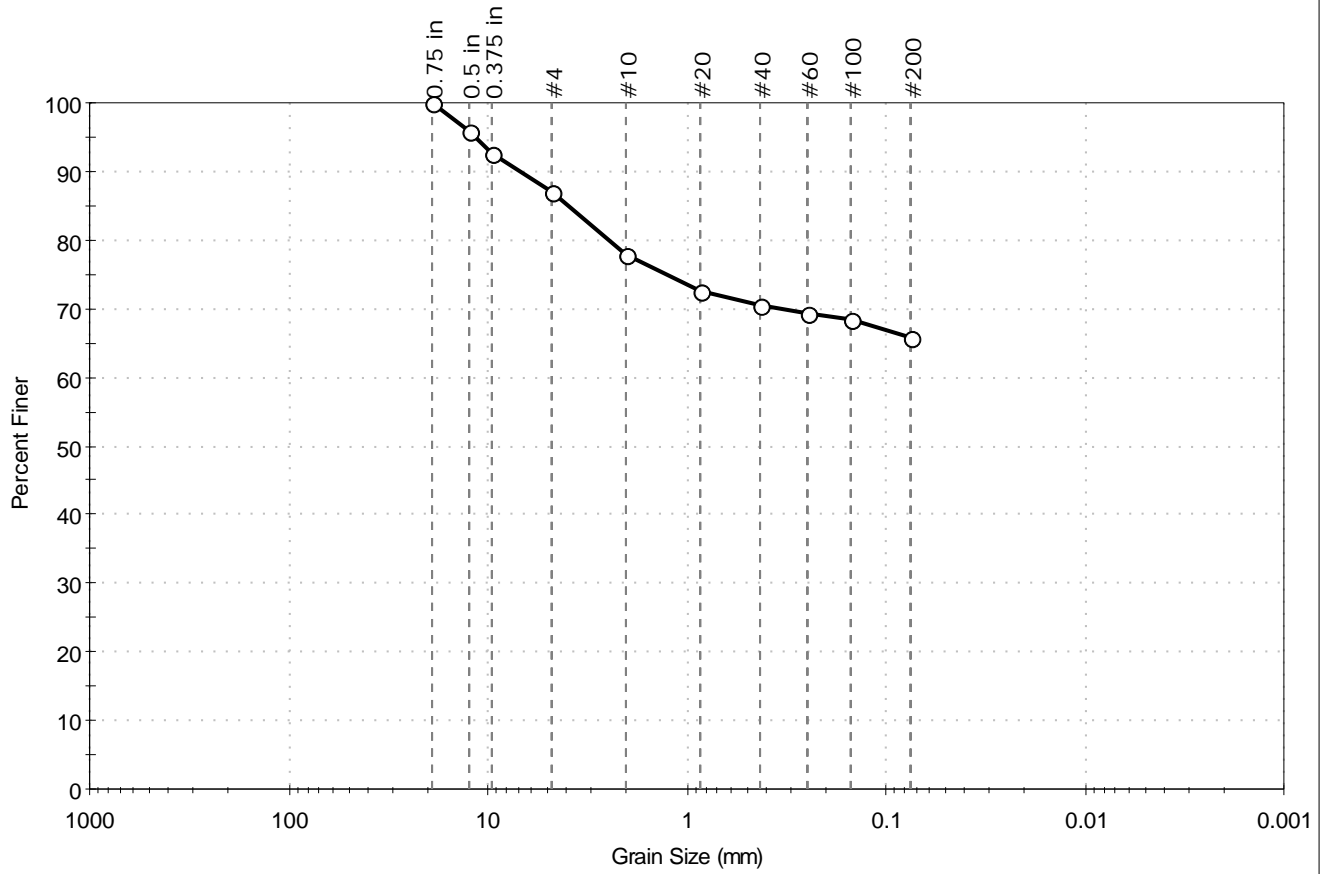

% Cobble	% Gravel	% Sand	% Silt & Clay Size
--	13.1	21.1	65.8

Sieve Name	Sieve Size, mm	Percent Finer	Spec. Percent	Complies
0.75 in	19.00	100		
0.5 in	12.50	96		
0.375 in	9.50	93		
#4	4.75	87		
#10	2.00	78		
#20	0.85	73		
#40	0.42	70		
#60	0.25	69		
#100	0.15	68		
#200	0.075	66		

<u>Coefficients</u>	
D ₈₅ = 3.9436 mm	D ₃₀ = N/A
D ₆₀ = N/A	D ₁₅ = N/A
D ₅₀ = N/A	D ₁₀ = N/A
C _u = N/A	C _c = N/A

<u>Classification</u>	
<u>ASTM</u>	Sandy Lean clay (CL)
<u>AASHTO</u>	Clayey Soils (A-6 (10))

<u>Sample/Test Description</u>	
Sand/Gravel Particle Shape : ANGULAR	
Sand/Gravel Hardness : HARD	



Client: AECOM	Project: North Water Street - MGP	Location: Poughkeepsie, NY	Project No: GTX-306681
Boring ID: GT17-108	Sample Type: jar	Tested By: GA	
Sample ID: GT17-108 (8-13)	Test Date: 07/21/17	Checked By: emm	
Depth: 8-13 ft	Test Id: 416508		
Test Comment: ---			
Visual Description: Wet, very dark brown clay			
Sample Comment: ---			

Particle Size Analysis - ASTM D422

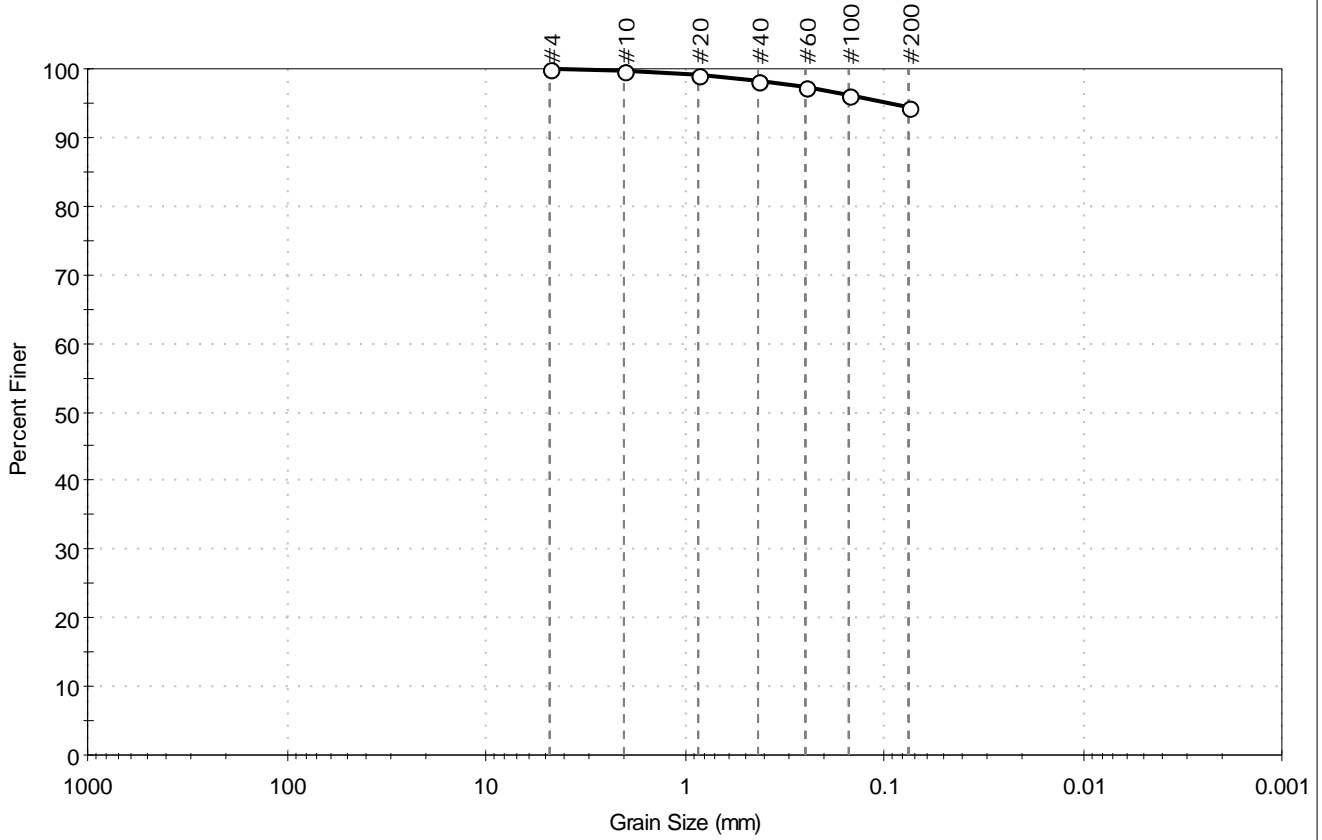

% Cobble	% Gravel	% Sand	% Silt & Clay Size
---	0.0	5.6	94.4

Sieve Name	Sieve Size, mm	Percent Finer	Spec. Percent	Complies
#4	4.75	100		
#10	2.00	100		
#20	0.85	99		
#40	0.42	98		
#60	0.25	97		
#100	0.15	96		
#200	0.075	94		

<u>Coefficients</u>	
D ₈₅ = N/A	D ₃₀ = N/A
D ₆₀ = N/A	D ₁₅ = N/A
D ₅₀ = N/A	D ₁₀ = N/A
C _u = N/A	C _c = N/A

<u>Classification</u>	
<u>ASTM</u>	Fat clay (CH)
<u>AASHTO</u>	Clayey Soils (A-7-5 (49))

<u>Sample/Test Description</u>
Sand/Gravel Particle Shape : ---
Sand/Gravel Hardness : ---



Client: AECOM	Project: North Water Street - MGP	Location: Poughkeepsie, NY	Project No: GTX-306681
Boring ID: GT17-108	Sample Type: jar	Tested By: GA	Checked By: emm
Sample ID: GT17-108 (20-25)	Test Date: 07/21/17	Test Id: 416509	
Depth: 20-25 ft			
Test Comment: ---	Visual Description: Moist, very dark gray clayey gravel with sand		
Sample Comment: ---			

Particle Size Analysis - ASTM D422

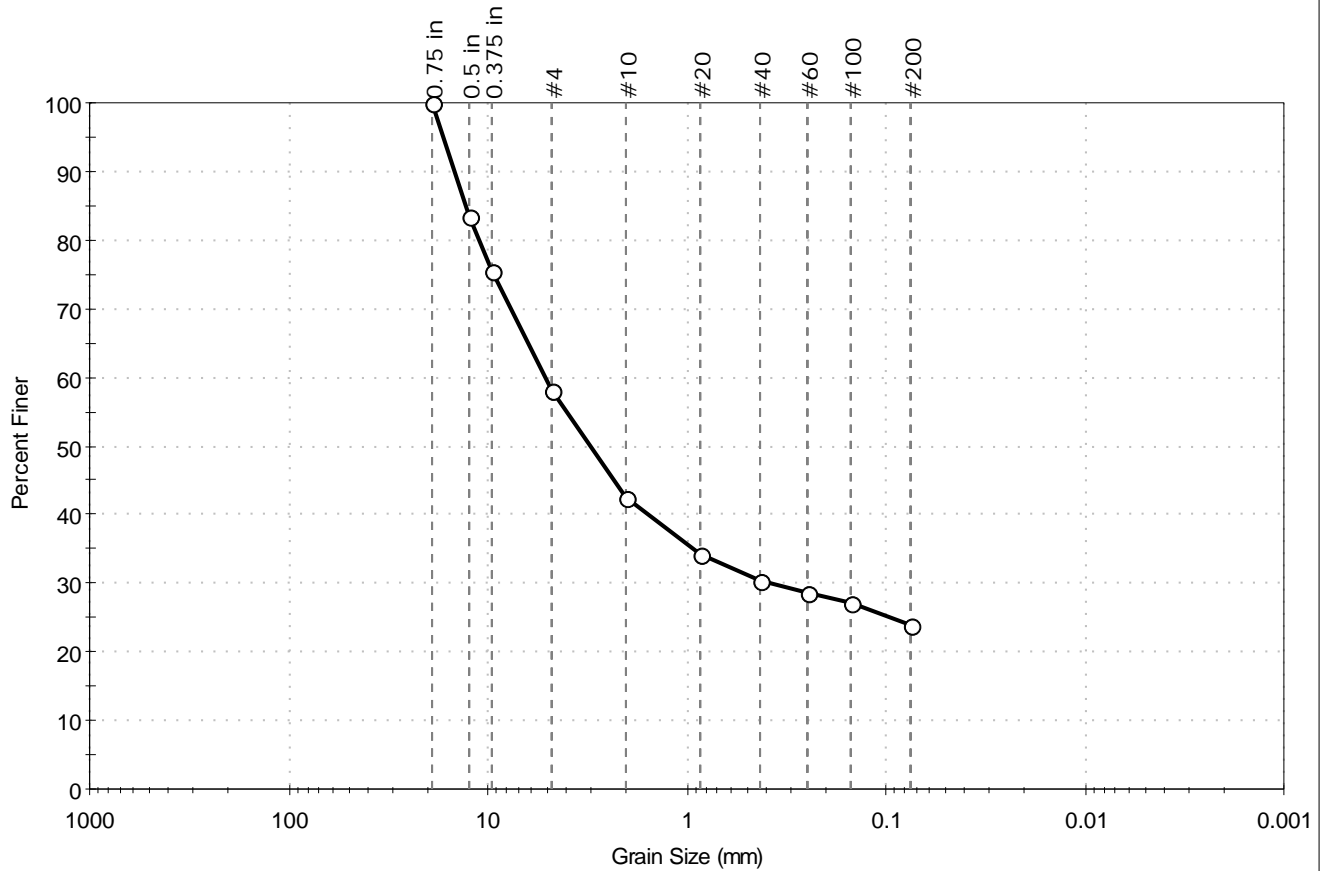

% Cobble	% Gravel	% Sand	% Silt & Clay Size
--	41.9	34.3	23.8

Sieve Name	Sieve Size, mm	Percent Finer	Spec. Percent	Complies
0.75 in	19.00	100		
0.5 in	12.50	84		
0.375 in	9.50	75		
#4	4.75	58		
#10	2.00	42		
#20	0.85	34		
#40	0.42	30		
#60	0.25	29		
#100	0.15	27		
#200	0.075	24		

<u>Coefficients</u>	
D ₈₅ = 12.9630 mm	D ₃₀ = 0.3929 mm
D ₆₀ = 5.1262 mm	D ₁₅ = N/A
D ₅₀ = 3.0400 mm	D ₁₀ = N/A
C _u = N/A	C _c = N/A

<u>Classification</u>	
<u>ASTM</u>	Clayey gravel with sand (GC)
<u>AASHTO</u>	Clayey Gravel and Sand (A-2-7 (1))

<u>Sample/Test Description</u>	
Sand/Gravel Particle Shape : ANGULAR	
Sand/Gravel Hardness : HARD	



Client:	AECOM		
Project:	North Water Street - MGP		
Location:	Poughkeepsie, NY	Project No:	GTX-306681
Boring ID:	GT17-100	Sample Type:	jar
Sample ID:	GT17-100 (19-21)	Test Date:	07/20/17
Depth :	19-21 ft	Test Id:	416510
Test Comment:	---		
Visual Description:	Moist, very dark gray silty sand with gravel		
Sample Comment:	---		

Atterberg Limits - ASTM D4318

Sample Determined to be non-plastic

Symbol	Sample ID	Boring	Depth	Natural Moisture Content, %	Liquid Limit	Plastic Limit	Plasticity Index	Liquidity Index	Soil Classification
◆	GT17-100 (19-21)	GT17-100	19-21 ft	19	n/a	n/a	n/a	n/a	Silty sand with gravel (SM)

64% Retained on #40 Sieve
 Dry Strength: NONE
 Dilatancy: RAPID
 Toughness: n/a
 The sample was determined to be Non-Plastic



Client:	AECOM		Project No:	GTX-306681	
Project:	North Water Street - MGP		Boring ID:	GT17-100	
Location:	Poughkeepsie, NY		Sample Type:	jar	
Tested By:	GA		Sample ID:	GT17-100 (27-29)	
Checked By:	emm		Test Date:	07/20/17	
Test Id:	416511		Depth :	27-29 ft	
Test Comment:	---				
Visual Description:	Moist, very dark brown clay				
Sample Comment:	---				

Atterberg Limits - ASTM D4318

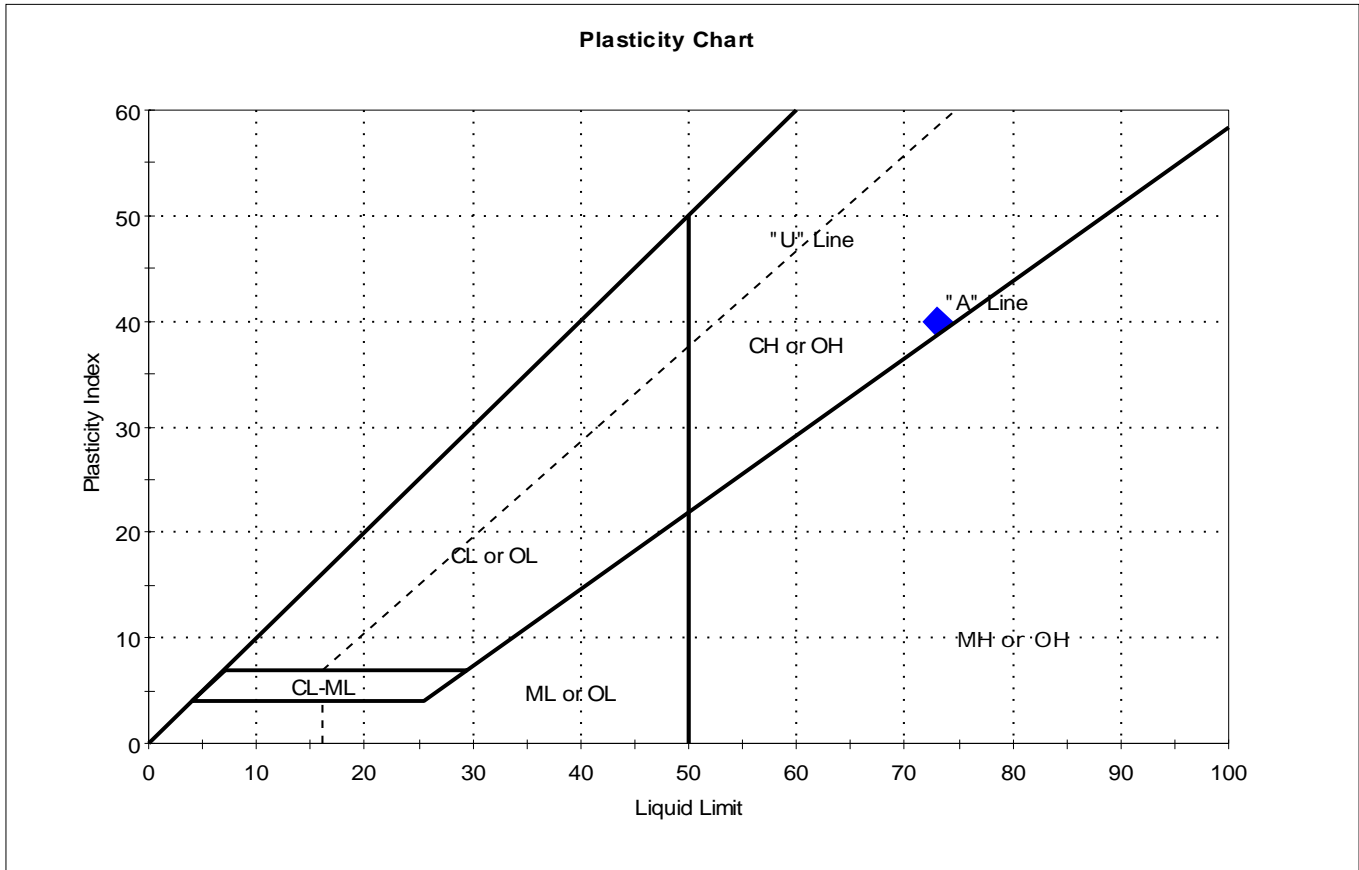

Symbol	Sample ID	Boring	Depth	Natural Moisture Content, %	Liquid Limit	Plastic Limit	Plasticity Index	Liquidity Index	Soil Classification
◆	GT17-100 (27-29)	GT17-100	27-29 ft	73	73	33	40	1	Fat clay (CH)

Sample Prepared using the WET method
 1% Retained on #40 Sieve
 Dry Strength: HIGH
 Dilatancy: SLOW
 Toughness: MEDIUM



Client:	AECOM		
Project:	North Water Street - MGP		
Location:	Poughkeepsie, NY	Project No:	GTX-306681
Boring ID:	GT17-101	Sample Type:	jar
Sample ID:	GT17-101 (15-18)	Test Date:	07/20/17
Depth :	15-18 ft	Test Id:	416512
Test Comment:	---		
Visual Description:	Moist, very dark gray gravel with silt and sand		
Sample Comment:	---		

Atterberg Limits - ASTM D4318

Sample Determined to be non-plastic

Symbol	Sample ID	Boring	Depth	Natural Moisture Content, %	Liquid Limit	Plastic Limit	Plasticity Index	Liquidity Index	Soil Classification
◆	GT17-101 (15-18)	GT17-101	15-18 ft	13	n/a	n/a	n/a	n/a	Well-graded gravel with silt and sand (GW-GM)

84% Retained on #40 Sieve
 Dry Strength: NONE
 Dilatancy: RAPID
 Toughness: n/a
 The sample was determined to be Non-Plastic



Client:	AECOM		Project No:	GTX-306681				
Project:	North Water Street - MGP		Boring ID:	GT17-101	Sample Type:	jar	Tested By:	GA
Location:	Poughkeepsie, NY		Sample ID:	GT17-101 (27-28)	Test Date:	07/21/17	Checked By:	emm
	Depth :	27-28 ft		Test Id:	416513			
Test Comment:	---							
Visual Description:	Moist, very dark gray clayey sand with gravel							
Sample Comment:	---							

Atterberg Limits - ASTM D4318

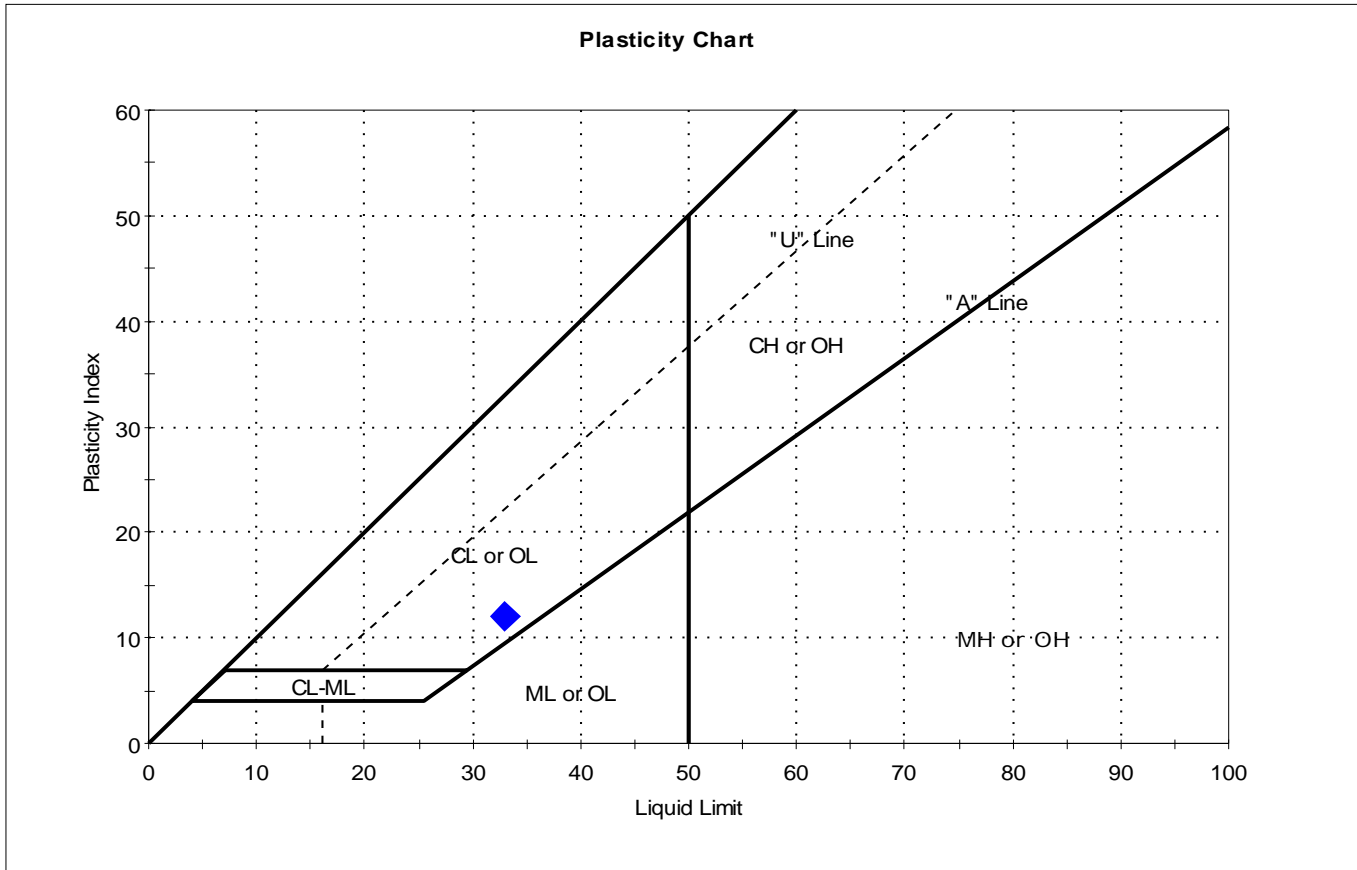

Symbol	Sample ID	Boring	Depth	Natural Moisture Content, %	Liquid Limit	Plastic Limit	Plasticity Index	Liquidity Index	Soil Classification
◆	GT17-101 (27-28)	GT17-101	27-28 ft	12	33	21	12	-0.7	Clayey sand with gravel (SC)

Sample Prepared using the WET method
 75% Retained on #40 Sieve
 Dry Strength: HIGH
 Dilatancy: SLOW
 Toughness: MEDIUM



Client:	AECOM		
Project:	North Water Street - MGP		
Location:	Poughkeepsie, NY	Project No:	GTX-306681
Boring ID:	GT17-102	Sample Type:	jar
Sample ID:	GT17-102 (11-14)	Test Date:	07/20/17
Depth :	11-14 ft	Test Id:	416514
Test Comment:	---		
Visual Description:	Moist, dark olive gray gravel with silt and sand		
Sample Comment:	---		

Atterberg Limits - ASTM D4318

Sample Determined to be non-plastic

Symbol	Sample ID	Boring	Depth	Natural Moisture Content, %	Liquid Limit	Plastic Limit	Plasticity Index	Liquidity Index	Soil Classification
◆	GT17-102 (11-14)	GT17-102	11-14 ft	13	n/a	n/a	n/a	n/a	Poorly graded gravel with silt and sand (GP-GM)

84% Retained on #40 Sieve
 Dry Strength: NONE
 Dilatancy: RAPID
 Toughness: n/a
 The sample was determined to be Non-Plastic



Client:	AECOM		Project No:	GTX-306681				
Project:	North Water Street - MGP		Boring ID:	GT17-102	Sample Type:	jar	Tested By:	GA
Location:	Poughkeepsie, NY		Sample ID:	GT17-102 (17-18)	Test Date:	07/20/17	Checked By:	emm
Depth :	17-18 ft		Test Id:	416515				
Test Comment:	---							
Visual Description:	Moist, very dark brown silt							
Sample Comment:	---							

Atterberg Limits - ASTM D4318

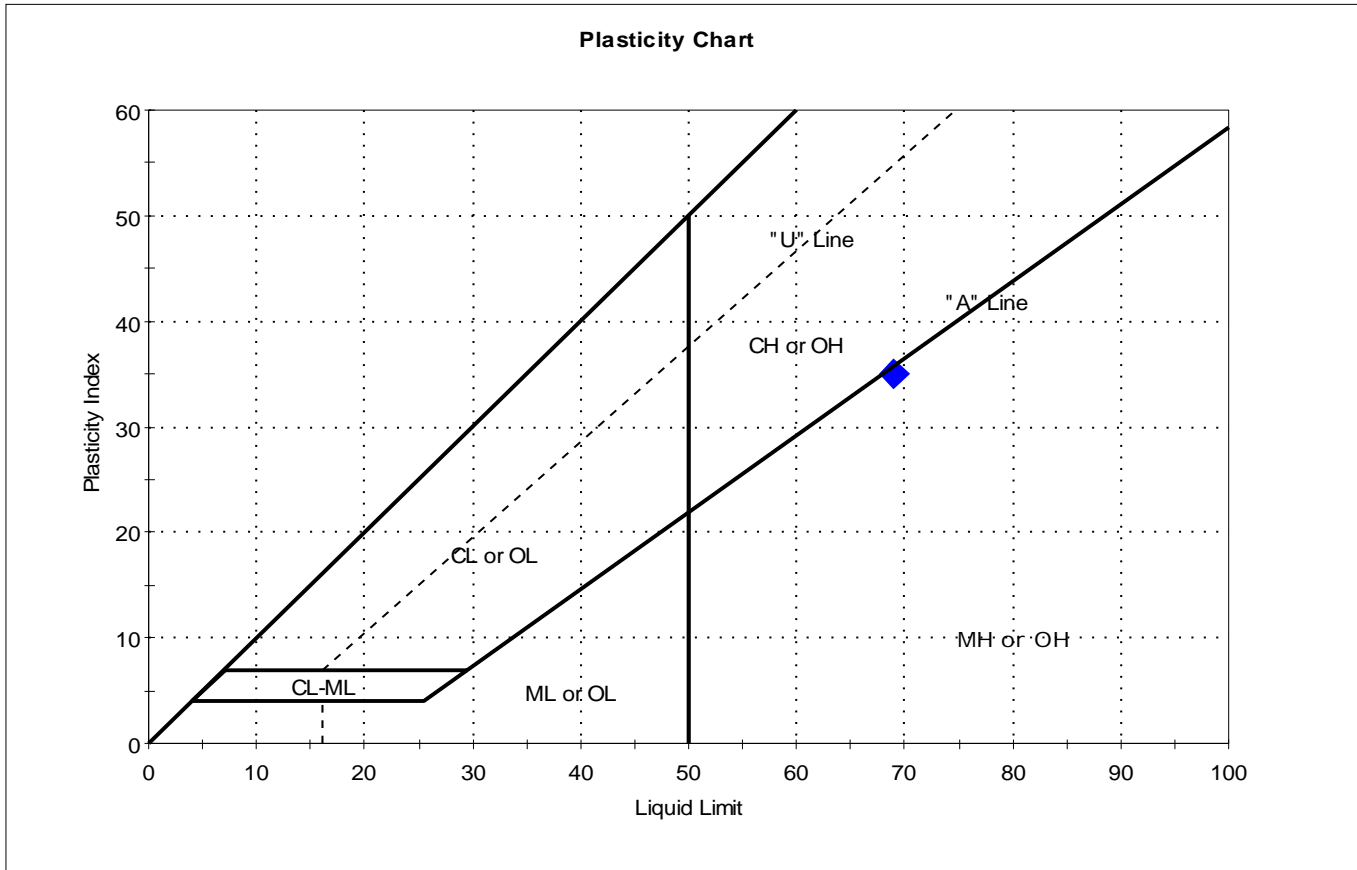

Symbol	Sample ID	Boring	Depth	Natural Moisture Content, %	Liquid Limit	Plastic Limit	Plasticity Index	Liquidity Index	Soil Classification
◆	GT17-102 (17-18)	GT17-102	17-18 ft	54	69	34	35	0.6	Elastic silt (MH)

Sample Prepared using the WET method
 4% Retained on #40 Sieve
 Dry Strength: HIGH
 Dilatancy: SLOW
 Toughness: MEDIUM



Client:	AECOM		Project No:	GTX-306681	
Project:	North Water Street - MGP		Boring ID:	GT17-103	
Location:	Poughkeepsie, NY		Sample Type:	jar	
Tested By:	GA		Sample ID:	GT17-103 (12-15)	
Checked By:	emm		Test Date:	07/21/17	
Test Id:	416516		Depth :	12-15 ft	
Test Comment:	---				
Visual Description:	Moist, very dark gray sandy silt with gravel				
Sample Comment:	---				

Atterberg Limits - ASTM D4318

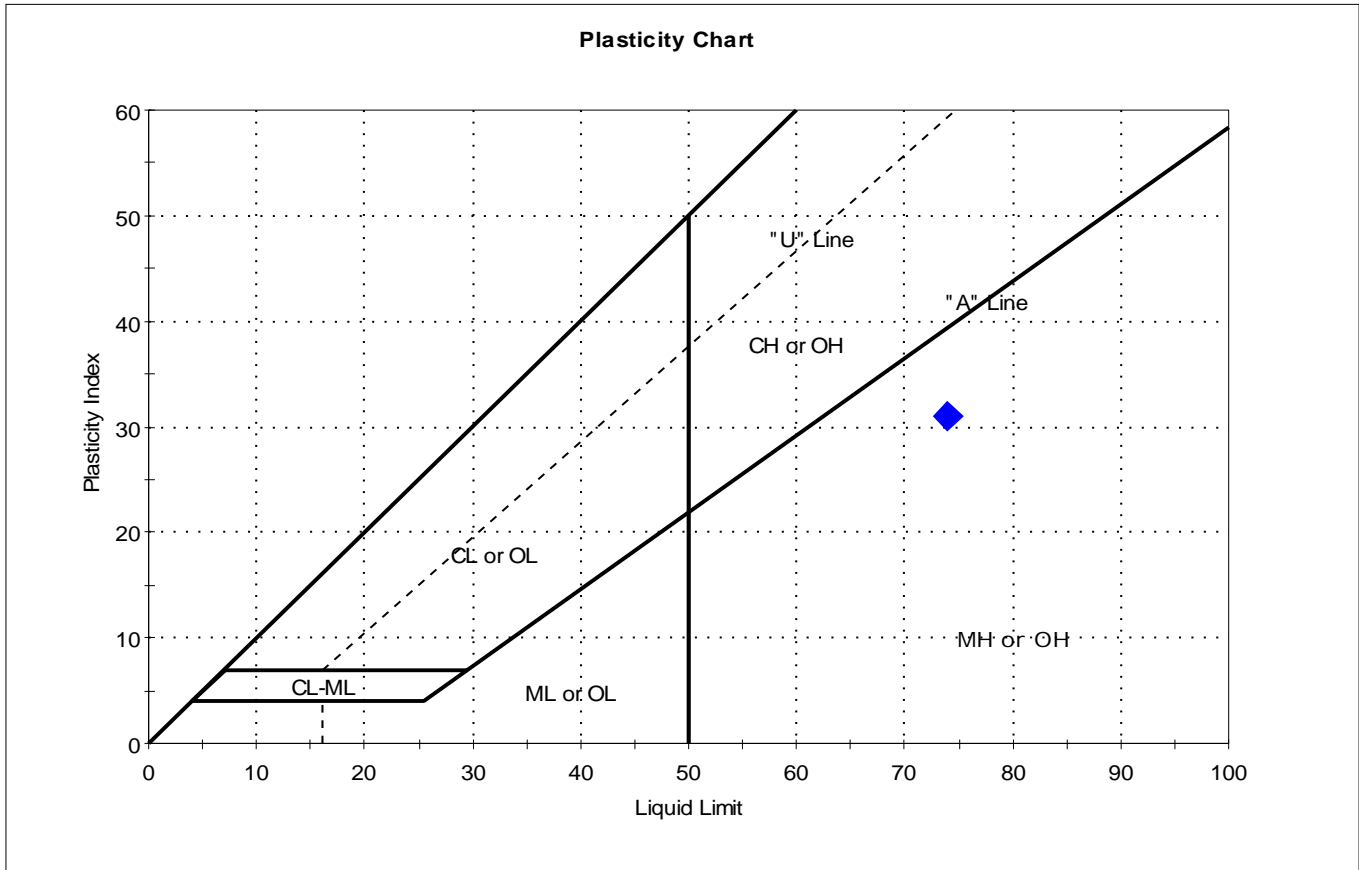

Symbol	Sample ID	Boring	Depth	Natural Moisture Content, %	Liquid Limit	Plastic Limit	Plasticity Index	Liquidity Index	Soil Classification
◆	GT17-103 (12-15)	GT17-103	12-15 ft	58	74	43	31	0.5	Sandy Elastic silt with gravel (MH)

Sample Prepared using the WET method
 36% Retained on #40 Sieve
 Dry Strength: MEDIUM
 Dilatancy: RAPID
 Toughness: MEDIUM



Client:	AECOM		Project No:	GTX-306681	
Project:	North Water Street - MGP		Boring ID:	GT17-103	
Location:	Poughkeepsie, NY		Sample Type:	jar	
Tested By:	GA		Sample ID:	GT17-103 (16-19)	
Checked By:	emm		Test Date:	07/20/17	
Test Id:	416517		Depth :	16-19 ft	
Test Comment:	---				
Visual Description:	Moist, very dark gray clayey gravel with sand				
Sample Comment:	---				

Atterberg Limits - ASTM D4318

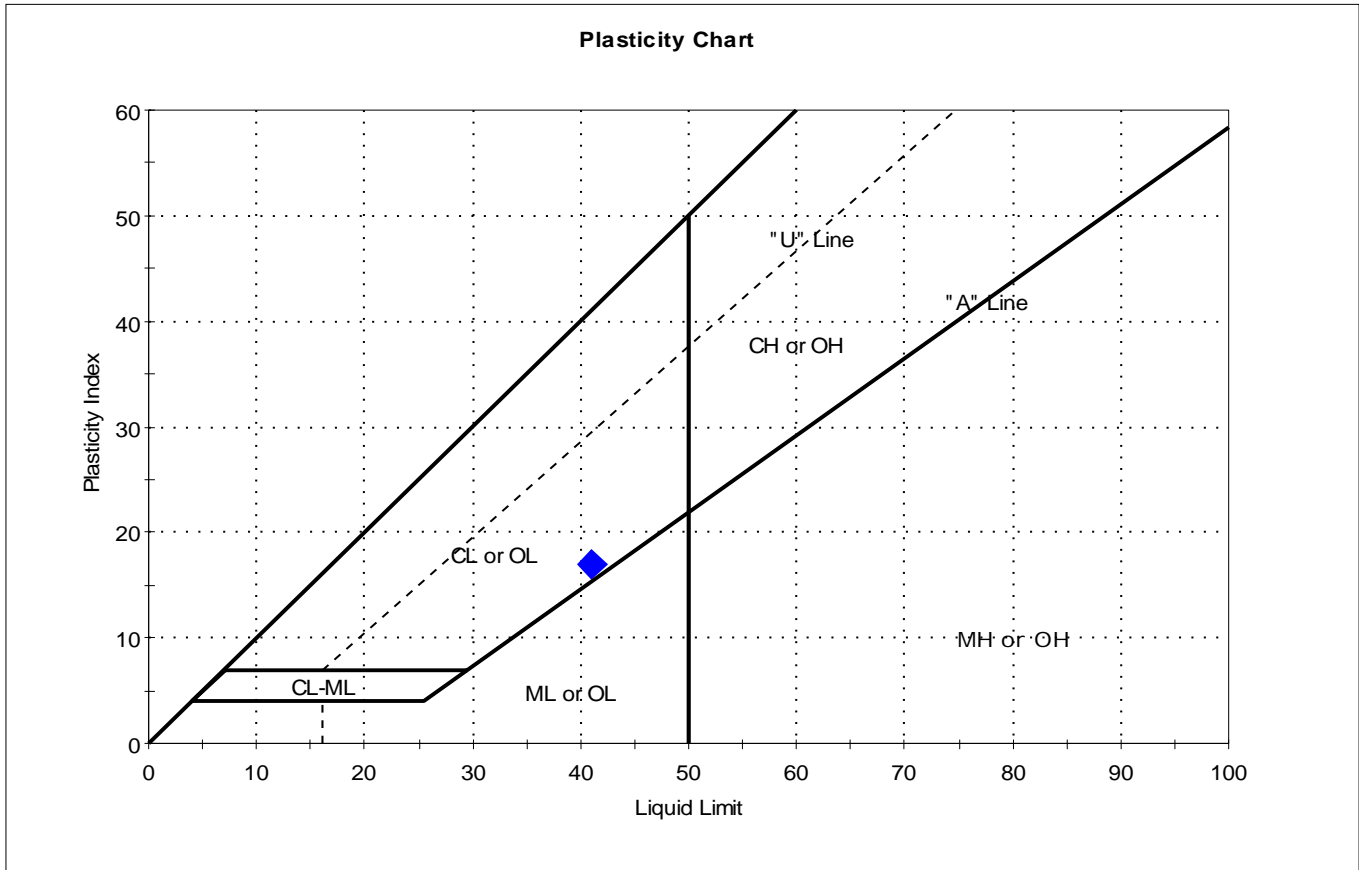

Symbol	Sample ID	Boring	Depth	Natural Moisture Content, %	Liquid Limit	Plastic Limit	Plasticity Index	Liquidity Index	Soil Classification
◆	GT17-103 (16-19)	GT17-103	16-19 ft	11	41	24	17	-0.8	Clayey gravel with sand (GC)

Sample Prepared using the WET method
 78% Retained on #40 Sieve
 Dry Strength: HIGH
 Dilatancy: SLOW
 Toughness: MEDIUM



Client:	AECOM		Project No:	GTX-306681				
Project:	North Water Street - MGP		Boring ID:	GT17-104	Sample Type:	jar	Tested By:	GA
Location:	Poughkeepsie, NY		Sample ID:	GT17-104 (13-15)	Test Date:	07/21/17	Checked By:	emm
	Depth :	13-15 ft		Test Id:	416518			
Test Comment:	---							
Visual Description:	Moist, very dark brown silt							
Sample Comment:	---							

Atterberg Limits - ASTM D4318

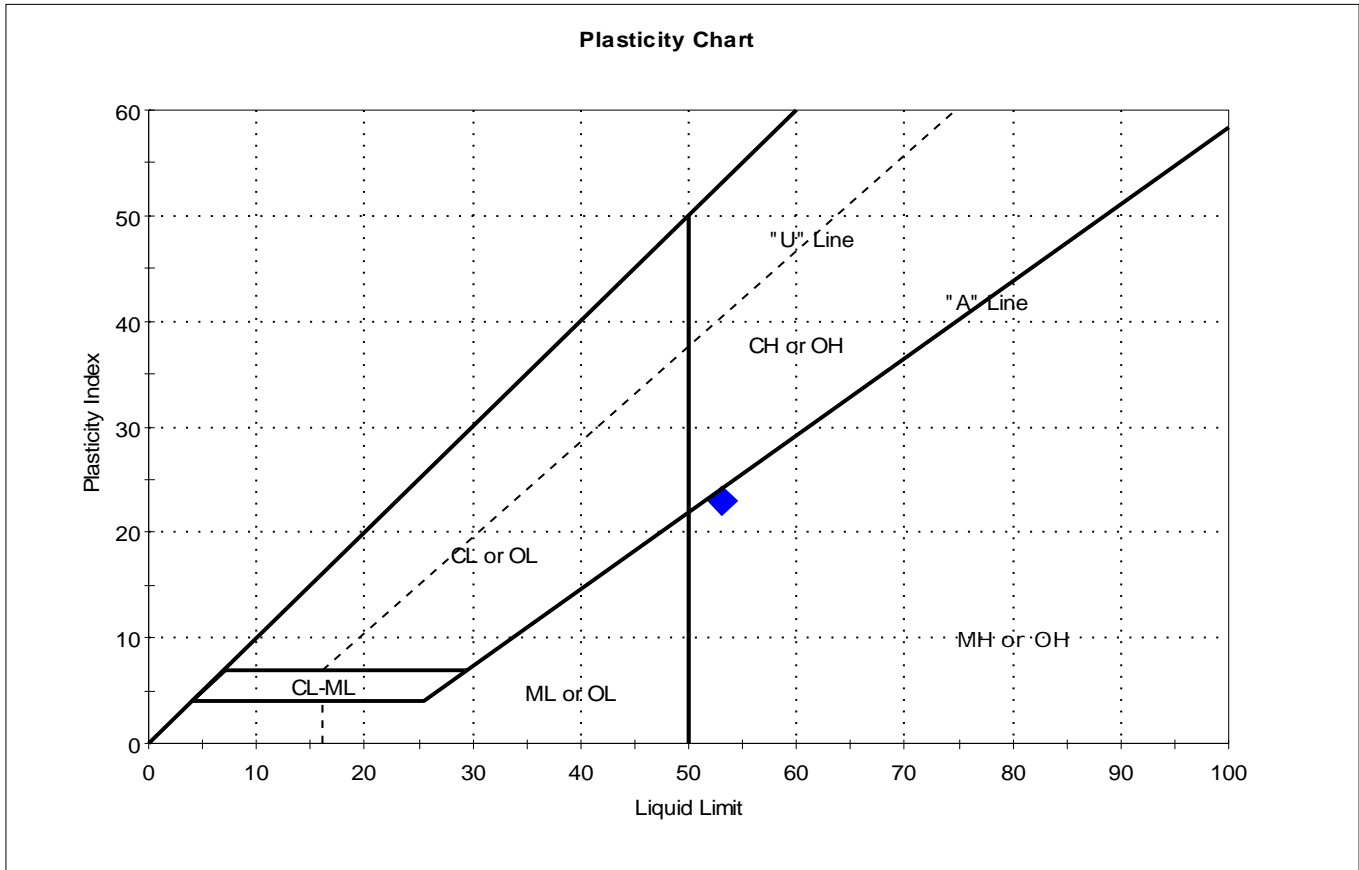

Symbol	Sample ID	Boring	Depth	Natural Moisture Content, %	Liquid Limit	Plastic Limit	Plasticity Index	Liquidity Index	Soil Classification
◆	GT17-104 (13-15)	GT17-104	13-15 ft	54	53	30	23	1	Elastic silt (MH)

Sample Prepared using the WET method
 9% Retained on #40 Sieve
 Dry Strength: HIGH
 Dilatancy: NONE
 Toughness: MEDIUM



Client:	AECOM		Project No:	GTX-306681				
Project:	North Water Street - MGP		Boring ID:	GT17-104	Sample Type:	jar	Tested By:	GA
Location:	Poughkeepsie, NY		Sample ID:	GT17-104 (17-19)	Test Date:	07/21/17	Checked By:	emm
	Depth :	17-19 ft		Test Id:	416519			
Test Comment:	---							
Visual Description:	Moist, very dark gray clayey gravel with sand							
Sample Comment:	---							

Atterberg Limits - ASTM D4318

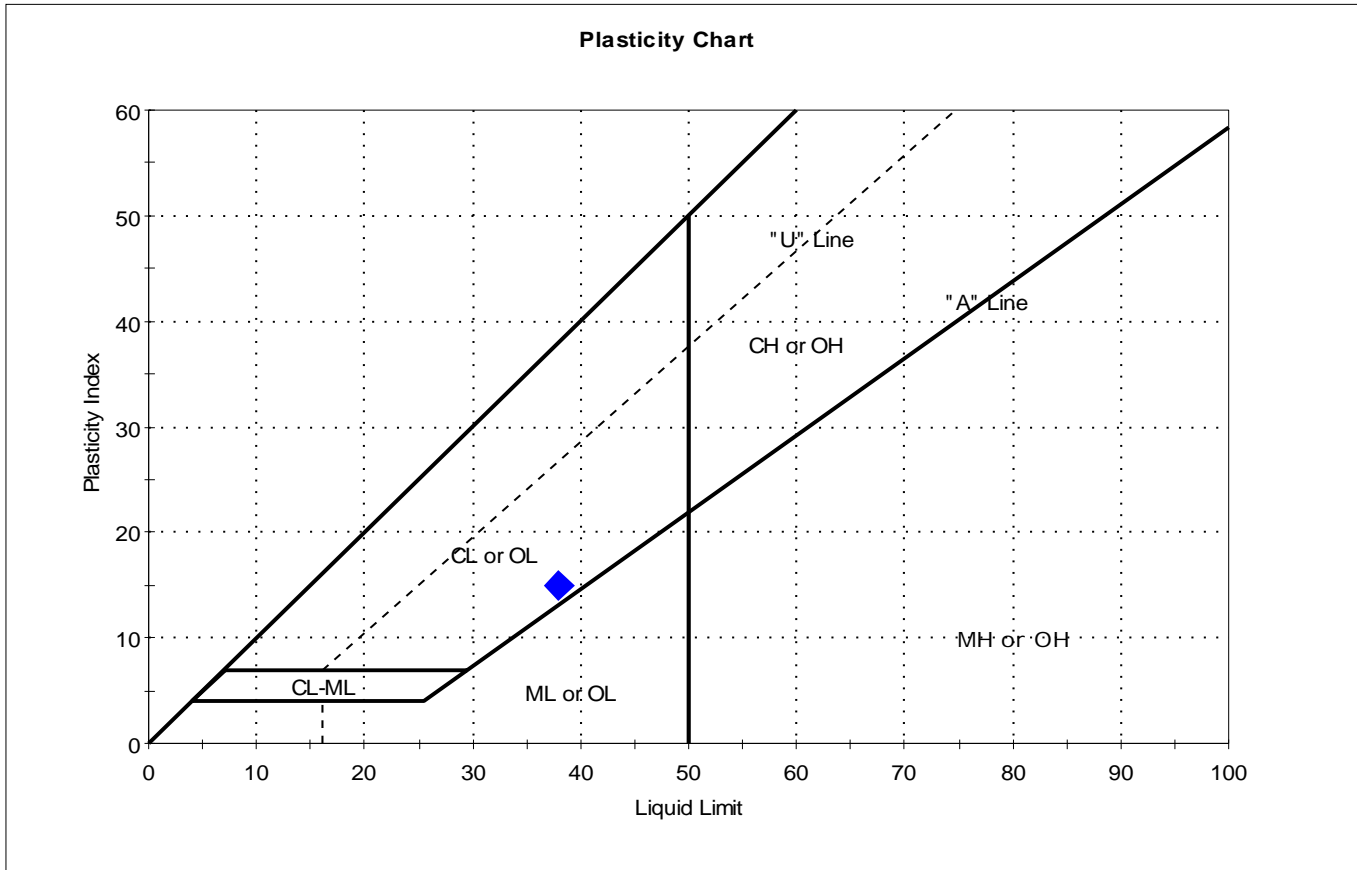

Symbol	Sample ID	Boring	Depth	Natural Moisture Content, %	Liquid Limit	Plastic Limit	Plasticity Index	Liquidity Index	Soil Classification
◆	GT17-104 (17-19)	GT17-104	17-19 ft	14	38	23	15	-0.6	Clayey gravel with sand (GC)

Sample Prepared using the WET method
 72% Retained on #40 Sieve
 Dry Strength: HIGH
 Dilatancy: NONE
 Toughness: MEDIUM



Client:	AECOM		
Project:	North Water Street - MGP		
Location:	Poughkeepsie, NY	Project No:	GTX-306681
Boring ID:	GT17-105	Sample Type:	jar
Sample ID:	GT17-105 (6-8)	Test Date:	07/20/17
Depth :	6-8 ft	Test Id:	416520
Test Comment:	---		
Visual Description:	Moist, very dark gray gravel with silt and sand		
Sample Comment:	---		

Atterberg Limits - ASTM D4318

Sample Determined to be non-plastic

Symbol	Sample ID	Boring	Depth	Natural Moisture Content, %	Liquid Limit	Plastic Limit	Plasticity Index	Liquidity Index	Soil Classification
◆	GT17-105 (6-8)	GT17-105	6-8 ft	17	n/a	n/a	n/a	n/a	Poorly graded gravel with silt and sand (GP-GM)

89% Retained on #40 Sieve
 Dry Strength: NONE
 Dilatancy: RAPID
 Toughness: n/a
 The sample was determined to be Non-Plastic



Client:	AECOM		
Project:	North Water Street - MGP		
Location:	Poughkeepsie, NY	Project No:	GTX-306681
Boring ID:	GT17-105	Sample Type:	jar
Sample ID:	GT17-105 (10-14)	Test Date:	07/20/17
Depth :	10-14 ft	Test Id:	416521
Test Comment:	---		
Visual Description:	Moist, very dark gray sand with gravel		
Sample Comment:	---		

Atterberg Limits - ASTM D4318

Sample Determined to be non-plastic

Symbol	Sample ID	Boring	Depth	Natural Moisture Content, %	Liquid Limit	Plastic Limit	Plasticity Index	Liquidity Index	Soil Classification
◆	GT17-105 (10-14)	GT17-105	10-14 ft	18	n/a	n/a	n/a	n/a	Poorly graded sand with gravel (SP)

94% Retained on #40 Sieve
 Dry Strength: NONE
 Dilatancy: RAPID
 Toughness: n/a
 The sample was determined to be Non-Plastic



Client:	AECOM		Project No:	GTX-306681	
Project:	North Water Street - MGP		Sample Type:	jar	
Location:	Poughkeepsie, NY		Tested By:	GA	
Boring ID:	GT17-105	Sample ID:	GT17-105 (17-20)	Test Date:	07/20/17
Sample ID:	GT17-105 (17-20)	Test Id:	416522	Checked By:	emm
Depth :	17-20 ft		Test Comment:	---	
Visual Description:	Wet, very dark gray clay				
Sample Comment:	---				

Atterberg Limits - ASTM D4318

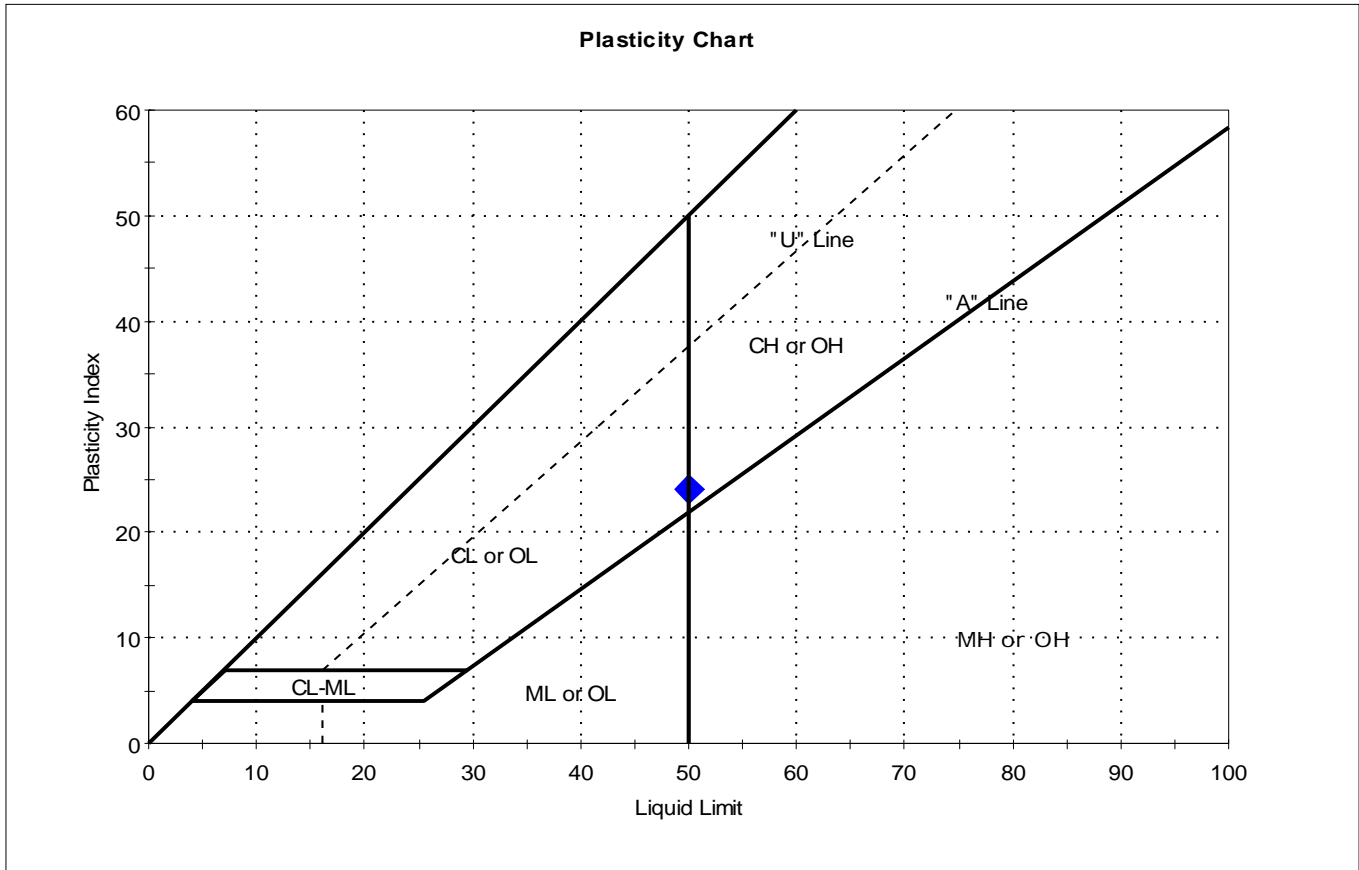

Symbol	Sample ID	Boring	Depth	Natural Moisture Content, %	Liquid Limit	Plastic Limit	Plasticity Index	Liquidity Index	Soil Classification
◆	GT17-105 (17-20)	GT17-105	17-20 ft	55	50	26	24	1.2	Fat clay (CH)

Sample Prepared using the WET method
 8% Retained on #40 Sieve
 Dry Strength: HIGH
 Dilatancy: SLOW
 Toughness: MEDIUM



Client:	AECOM		Project No:	GTX-306681	
Project:	North Water Street - MGP		Sample Type:	jar	
Location:	Poughkeepsie, NY		Tested By:	GA	
Boring ID:	GT17-106	Sample ID:	GT17-106 (10-14)	Test Date:	07/21/17
Sample ID:	GT17-106 (10-14)	Test Id:	416523	Checked By:	emm
Depth :	10-14ft		Test Comment:	---	
Visual Description:	Moist, very dark gray gravelly silt				
Sample Comment:	---				

Atterberg Limits - ASTM D4318

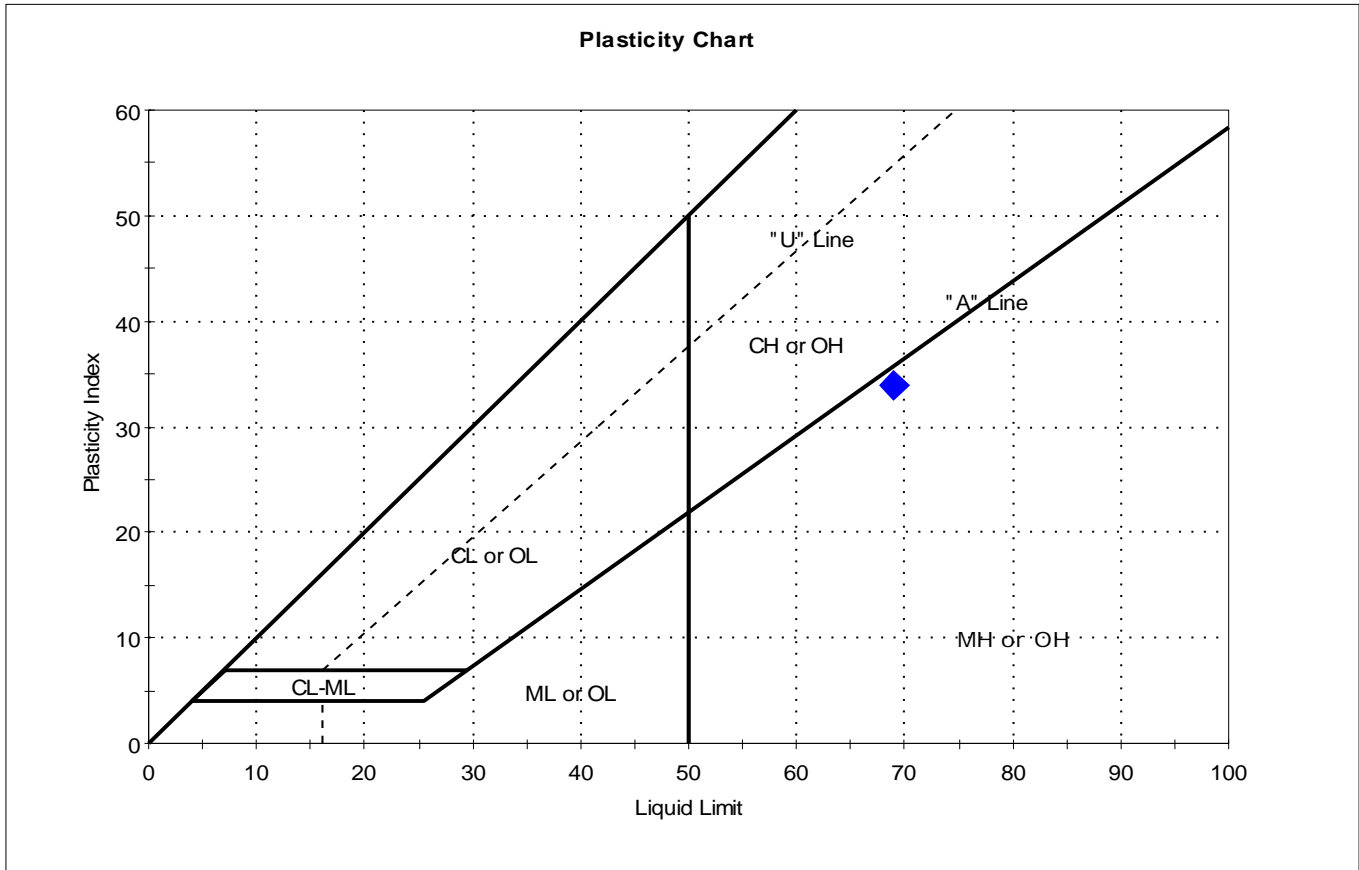

Symbol	Sample ID	Boring	Depth	Natural Moisture Content, %	Liquid Limit	Plastic Limit	Plasticity Index	Liquidity Index	Soil Classification
◆	GT17-106 (10-14)	GT17-106	10-14ft	65	69	35	34	0.9	Gravelly Elastic silt (MH)

Sample Prepared using the WET method
 29% Retained on #40 Sieve
 Dry Strength: MEDIUM
 Dilatancy: SLOW
 Toughness: MEDIUM



Client:	AECOM		
Project:	North Water Street - MGP		
Location:	Poughkeepsie, NY	Project No:	GTX-306681
Boring ID:	GT17-106	Sample Type:	jar
Sample ID:	GT17-106 (18-23)	Test Date:	07/20/17
Depth :	18-23 ft	Test Id:	416524
Test Comment:	---		
Visual Description:	Moist, very dark gray and pale yellow gravel with sand		
Sample Comment:	---		

Atterberg Limits - ASTM D4318

Sample Determined to be non-plastic

Symbol	Sample ID	Boring	Depth	Natural Moisture Content, %	Liquid Limit	Plastic Limit	Plasticity Index	Liquidity Index	Soil Classification
◆	GT17-106 (18-23)	GT17-106	18-23 ft	16	n/a	n/a	n/a	n/a	Well-graded gravel with sand (GW)

90% Retained on #40 Sieve
 Dry Strength: NONE
 Dilatancy: RAPID
 Toughness: n/a
 The sample was determined to be Non-Plastic



Client:	AECOM		Project No:	GTX-306681	
Project:	North Water Street - MGP		Sample Type:	jar	
Location:	Poughkeepsie, NY		Tested By:	GA	
Boring ID:	GT17-106	Sample ID:	GT17-106 (24-26)	Test Date:	07/20/17
Sample ID:	GT17-106 (24-26)	Test Id:	416525	Checked By:	emm
Depth :	24-26 ft				
Test Comment:	---				
Visual Description:	Wet, very dark gray clay				
Sample Comment:	---				

Atterberg Limits - ASTM D4318

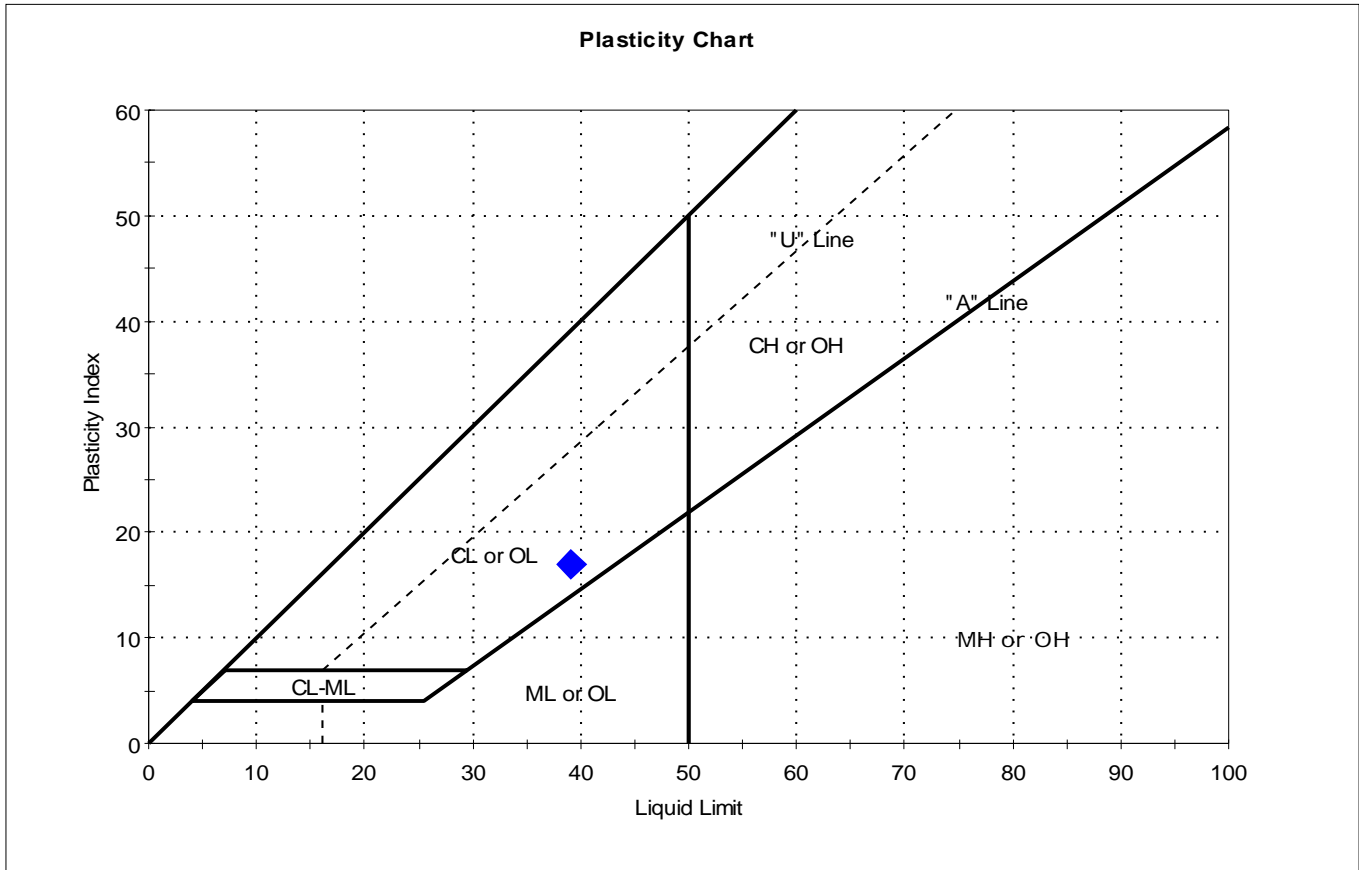

Symbol	Sample ID	Boring	Depth	Natural Moisture Content, %	Liquid Limit	Plastic Limit	Plasticity Index	Liquidity Index	Soil Classification
◆	GT17-106 (24-26)	GT17-106	24-26 ft	49	39	22	17	1.6	Lean clay (CL)

Sample Prepared using the WET method
 1% Retained on #40 Sieve
 Dry Strength: HIGH
 Dilatancy: SLOW
 Toughness: MEDIUM



Client:	AECOM		Project No:	GTX-306681				
Project:	North Water Street - MGP		Boring ID:	GT17-107	Sample Type:	jar	Tested By:	GA
Location:	Poughkeepsie, NY		Sample ID:	GT17-107 (30-38)	Test Date:	07/21/17	Checked By:	emm
Depth :	30-38 ft		Test Id:	416526				
Test Comment:	---							
Visual Description:	Moist, very dark gray sandy clay							
Sample Comment:	---							

Atterberg Limits - ASTM D4318

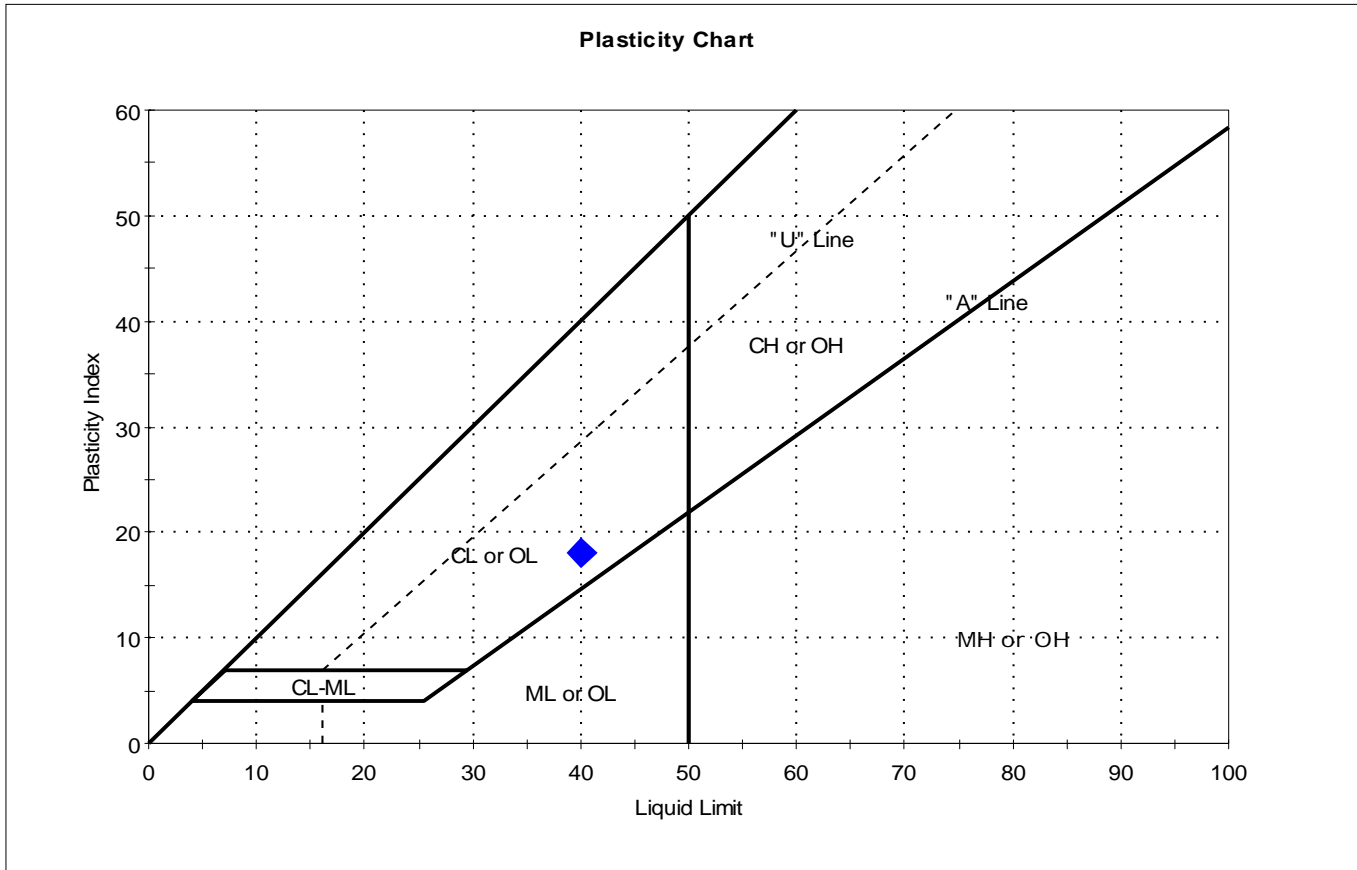

Symbol	Sample ID	Boring	Depth	Natural Moisture Content, %	Liquid Limit	Plastic Limit	Plasticity Index	Liquidity Index	Soil Classification
◆	GT17-107 (30-38)	GT17-107	30-38 ft	34	40	22	18	0.6	Sandy Lean clay (CL)

Sample Prepared using the WET method
 30% Retained on #40 Sieve
 Dry Strength: MEDIUM
 Dilatancy: SLOW
 Toughness: MEDIUM



Client:	AECOM		Project No:	GTX-306681				
Project:	North Water Street - MGP		Boring ID:	GT17-108	Sample Type:	jar	Tested By:	GA
Location:	Poughkeepsie, NY		Sample ID:	GT17-108 (8-13)	Test Date:	07/21/17	Checked By:	emm
	Depth :	8-13 ft	Test Id:	416527				
Test Comment:	---							
Visual Description:	Wet, very dark brown clay							
Sample Comment:	---							

Atterberg Limits - ASTM D4318

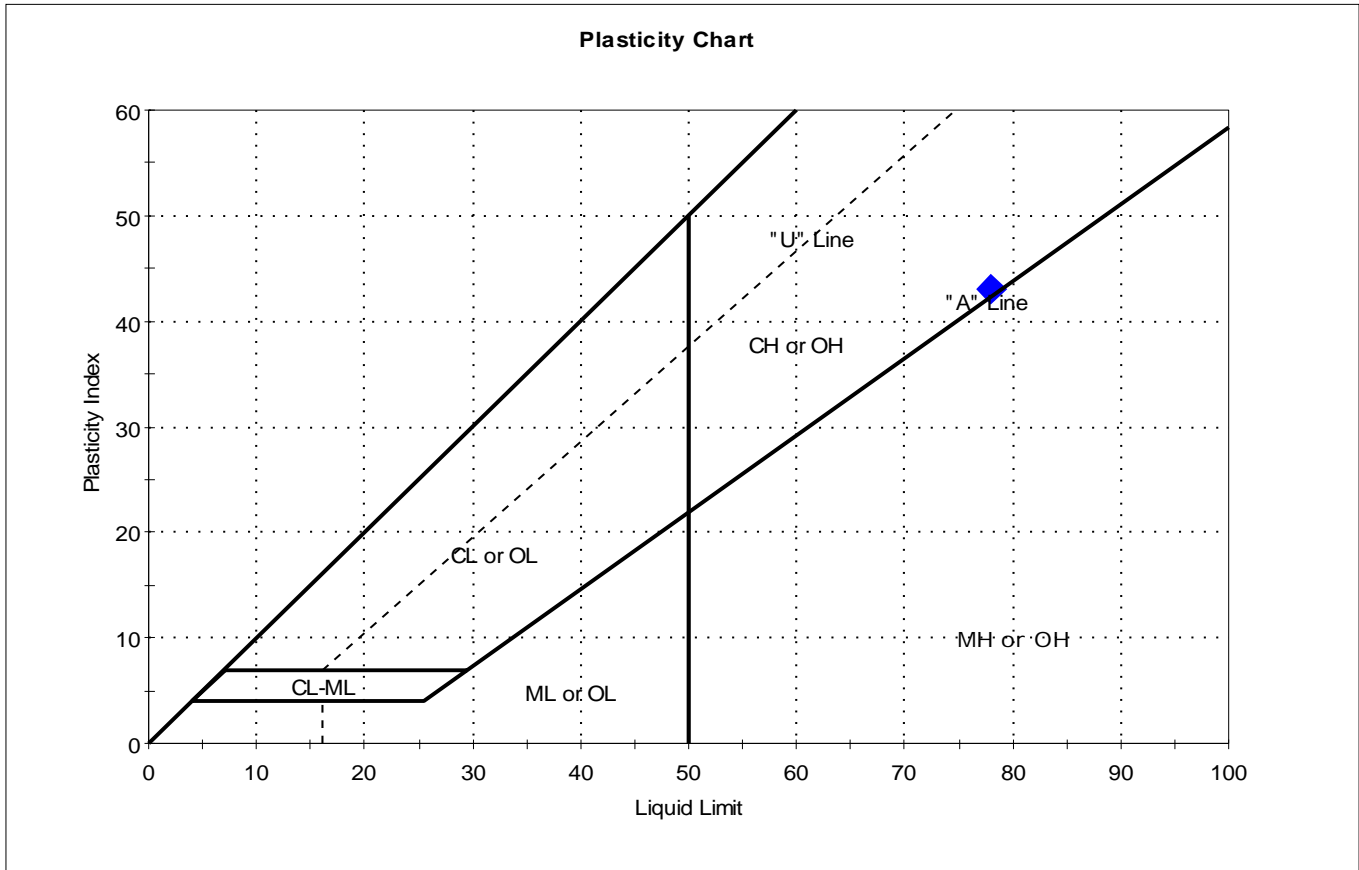

Symbol	Sample ID	Boring	Depth	Natural Moisture Content, %	Liquid Limit	Plastic Limit	Plasticity Index	Liquidity Index	Soil Classification
◆	GT17-108 (8-13)	GT17-108	8-13 ft	85	78	35	43	1.2	Fat clay (CH)

Sample Prepared using the WET method
 2% Retained on #40 Sieve
 Dry Strength: HIGH
 Dilatancy: NONE
 Toughness: MEDIUM



Client:	AECOM		Project No:	GTX-306681				
Project:	North Water Street - MGP		Boring ID:	GT17-108	Sample Type:	jar	Tested By:	GA
Location:	Poughkeepsie, NY		Sample ID:	GT17-108 (20-25)	Test Date:	07/21/17	Checked By:	emm
	Depth :	20-25 ft		Test Id:	416528			
Test Comment:	---							
Visual Description:	Moist, very dark gray clayey gravel with sand							
Sample Comment:	---							

Atterberg Limits - ASTM D4318

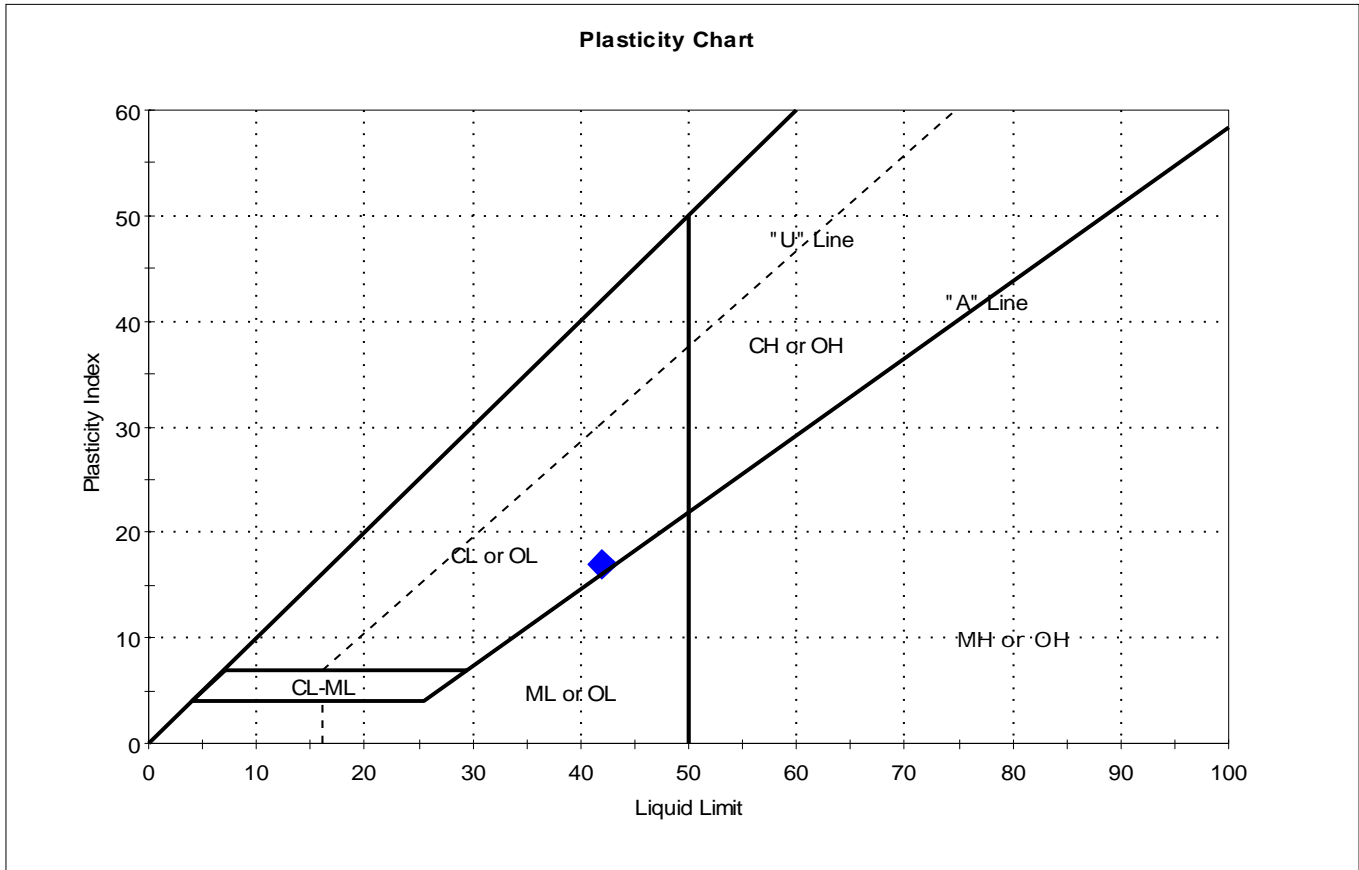

Symbol	Sample ID	Boring	Depth	Natural Moisture Content, %	Liquid Limit	Plastic Limit	Plasticity Index	Liquidity Index	Soil Classification
◆	GT17-108 (20-25)	GT17-108	20-25 ft	19	42	25	17	-0.4	Clayey gravel with sand (GC)

Sample Prepared using the WET method
 70% Retained on #40 Sieve
 Dry Strength: HIGH
 Dilatancy: SLOW
 Toughness: MEDIUM

Appendix E

Pre Design Investigation Test Pit Excavation Photo Log

Facility Name: Former North Water Street MGP Site	Site Location: 2 Dutchess Avenue, Poughkeepsie, New York	Project No.: 60540671
---	--	---------------------------------

Photo No.: 1	Date: 06/19/17	
Direction Photo Taken: South		
Description: TP17-100; Presence of concrete slab/footer within former Oil Storage Tank in the background (southern portion of the test pit) and inside of the former Tar Centrifuge House in the foreground (northern portion of test pit)		

Photo No.: 2	Date: 06/19/17	
Direction Photo Taken: North		
Description: TP17-100; Presence of concrete slab/footer within former Oil Storage Tank in the foreground (southern portion of the test pit) and inside of the former Tar Centrifuge House in the background (northern portion of test pit)		

Facility Name: Former North Water Street MGP Site	Site Location: 2 Dutchess Avenue, Poughkeepsie, New York	Project No.: 60540671
---	--	---------------------------------

Photo No.: 3	Date: 06/19/17	
Direction Photo Taken: East		
Description: TP17-100; Debris and soil removed from former Tar Centrifuge House; Looking into former Tar Centrifuge House		

Photo No.: 4	Date: 06/19/17	
Direction Photo Taken: North		
Description: TP17-100; Looking into former Tar Centrifuge House (northern portion of test pit)		

Facility Name: Former North Water Street MGP Site	Site Location: 2 Dutchess Avenue, Poughkeepsie, New York	Project No.: 60540671
---	--	---------------------------------

Photo No.: 5	Date: 06/19/17	
Direction Photo Taken: West		
Description: TP17-100; Looking into former Tar Centrifuge House (northern portion of test pit); slight staining below footer.		

Photo No.: 6	Date: 06/19/17	
Direction Photo Taken: West		
Description: TP17-101; Top three feet of excavation. Notice concrete foundations		

Facility Name: Former North Water Street MGP Site	Site Location: 2 Dutchess Avenue, Poughkeepsie, New York	Project No.: 60540671
---	--	---------------------------------

Photo No. 7	Date: 06/19/17
Direction Photo Taken: East	
Description: TP17-101; wall of former Oil Storage Tank; notice concrete slab within structure observed during TP17-100 excavation	



Photo No. 8	Date: 06/19/17
Direction Photo Taken: West	
Description: TP17-101; soil beneath various tanks	



Facility Name: Former North Water Street MGP Site	Site Location: 2 Dutchess Avenue, Poughkeepsie, New York	Project No.: 60540671
---	--	---------------------------------

Photo No. 9	Date: 06/19/17
Direction Photo Taken: West	
Description: TP17-101; foundation of Former tar tank or oil tank	



Photo No. 10	Date: 06/19/17
Direction Photo Taken: West	
Description: TP17-101; sight staining and odors beneath foundation of Former tar tank or oil tank	



Facility Name: Former North Water Street MGP Site	Site Location: 2 Dutchess Avenue, Poughkeepsie, New York	Project No.: 60540671
---	--	---------------------------------

Photo No. 11	Date: 06/19/17
Direction Photo Taken: N/A	
Description: TP17-101; Oil like material and oil like odor from soils removed over bedrock	

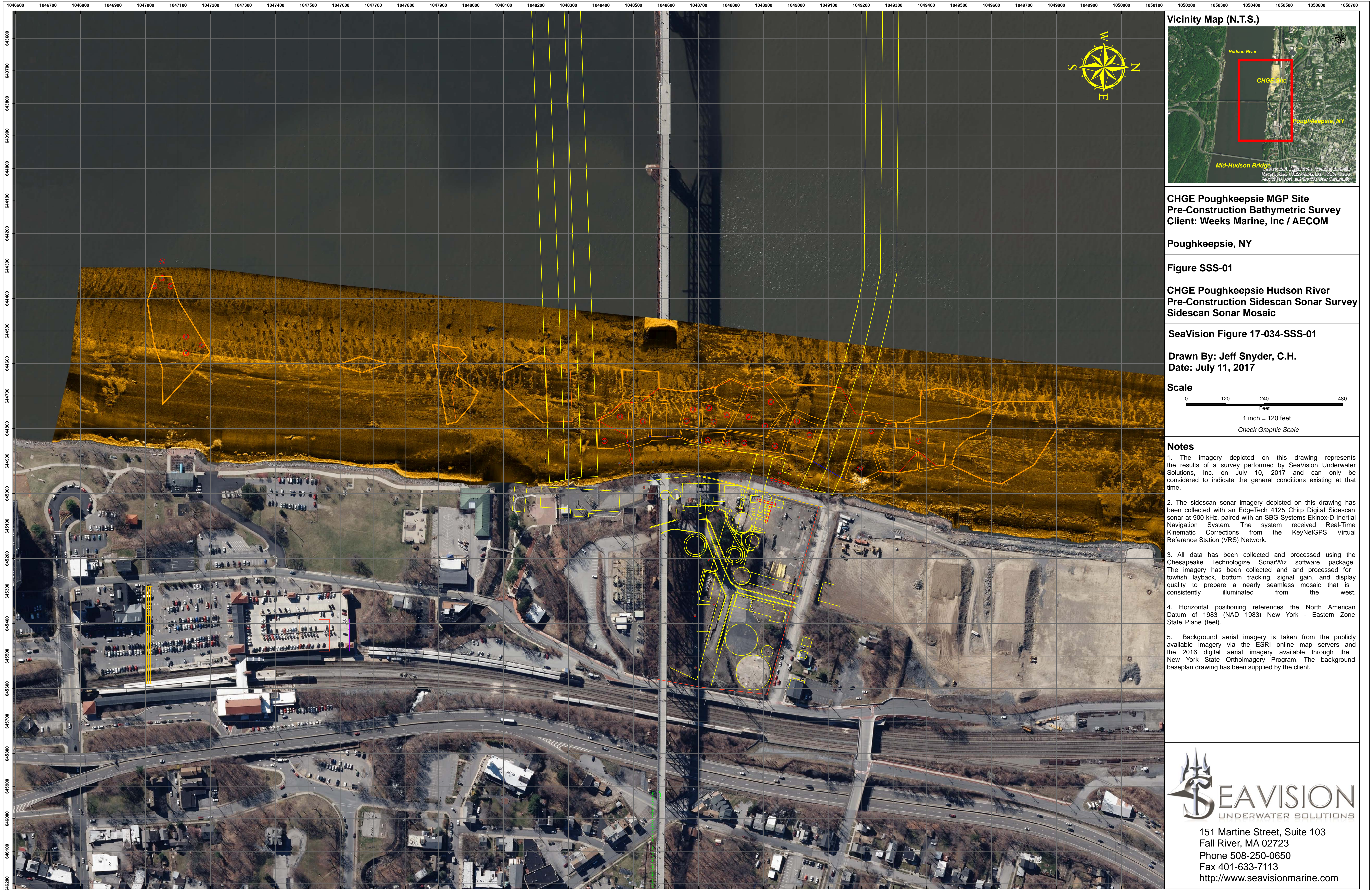

Photo No. 12	Date: 06/19/17
Direction Photo Taken: West	
Description: TP17-102; Barrier/bulkhead wall obstruction test pit	



Appendix F

Pre Design Investigation Bathymetry and Sidescan Survey Report



Vicinity Map (N.T.S.)



**CHGE Poughkeepsie MGP Site
Pre-Construction Bathymetric Survey
Client: Weeks Marine, Inc / AECOM**

Poughkeepsie, NY

Figure SSS-01

**CHGE Poughkeepsie Hudson River
Pre-Construction Sidescan Sonar Survey
Sidescan Sonar Mosaic**

SeaVision Figure 17-034-SSS-01

**Drawn By: Jeff Snyder, C.H.
Date: July 11, 2017**

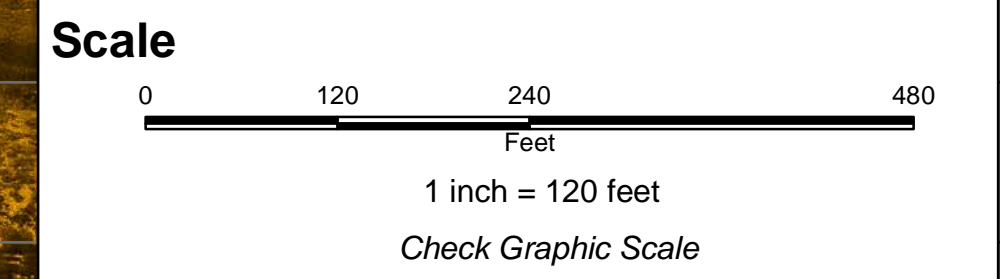

Notes

1. The imagery depicted on this drawing represents the results of a survey performed by SeaVision Underwater Solutions, Inc. on July 10, 2017 and can only be considered to indicate the general conditions existing at that time.
2. The sidescan sonar imagery depicted on this drawing has been collected with an EdgeTech 4125 Chirp Digital Sidescan sonar at 900 kHz, paired with an SBG Systems Ekinox-D Inertial Navigation System. The system received Real-Time Kinematic Corrections from the KeyNetGPS Virtual Reference Station (VRS) Network.
3. All data has been collected and processed using the Chesapeake Technologicize SonarWiz software package. The imagery has been collected and processed for towfish layback, bottom tracking, signal gain, and display quality to prepare a nearly seamless mosaic that is consistently illuminated from the west.
4. Horizontal positioning references the North American Datum of 1983 (NAD 1983) New York - Eastern Zone State Plane (feet).
5. Background aerial imagery is taken from the publicly available imagery via the ESRI online map servers and the 2016 digital aerial imagery available through the New York State Orthoimagery Program. The background baseplan drawing has been supplied by the client.



151 Martine Street, Suite 103
Fall River, MA 02723
Phone 508-250-0650
Fax 401-633-7113
<http://www.seavisionmarine.com>

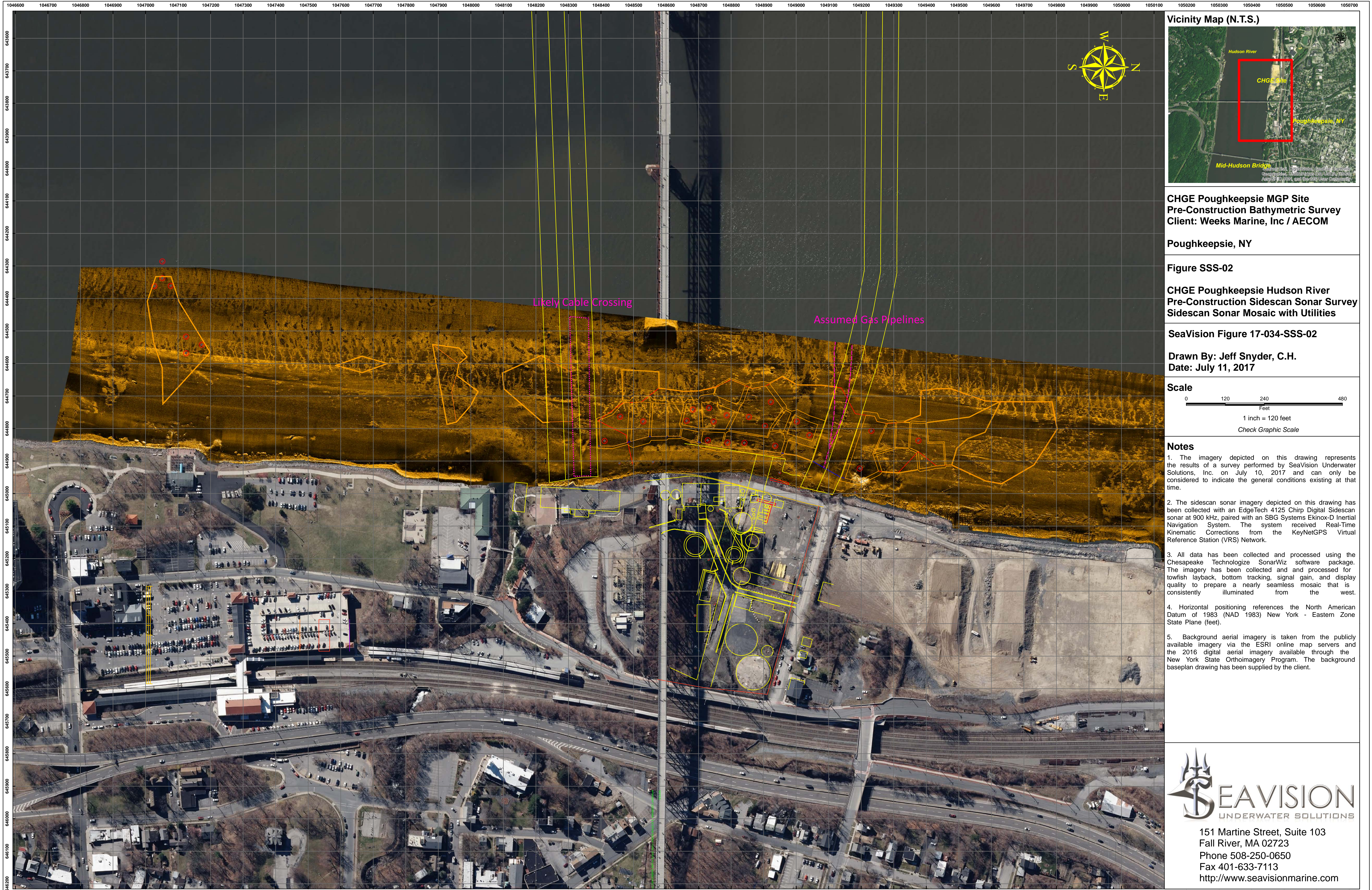

Vicinity Map (N.T.S.)

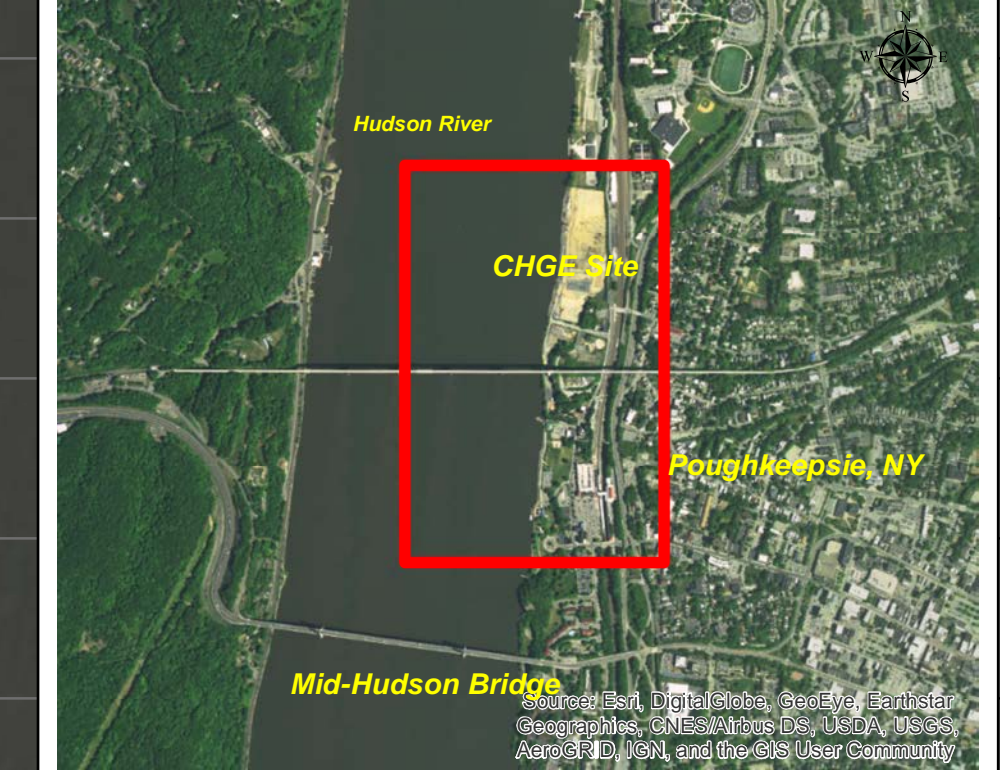

**CHGE Poughkeepsie MGP Site
Pre-Construction Bathymetric Survey
Client: Weeks Marine, Inc / AECOM**

Poughkeepsie, NY

Figure SSS-02

**CHGE Poughkeepsie Hudson River
Pre-Construction Sidescan Sonar Survey
Sidescan Sonar Mosaic with Utilities**

SeaVision Figure 17-034-SSS-02

**Drawn By: Jeff Snyder, C.H.
Date: July 11, 2017**

Scale

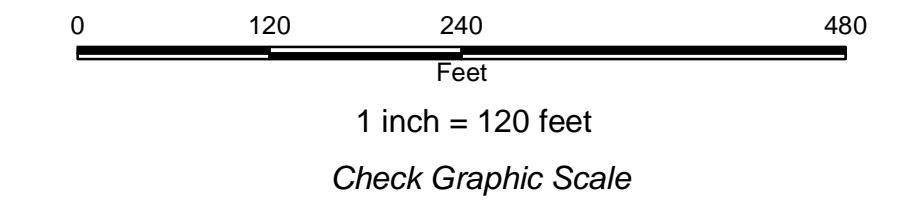

Notes

1. The imagery depicted on this drawing represents the results of a survey performed by SeaVision Underwater Solutions, Inc. on July 10, 2017 and can only be considered to indicate the general conditions existing at that time.
2. The sidescan sonar imagery depicted on this drawing has been collected with an EdgeTech 4125 Chirp Digital Sidescan sonar at 900 kHz, paired with an SBG Systems Ekinox-D Inertial Navigation System. The system received Real-Time Kinematic Corrections from the KeyNetGPS Virtual Reference Station (VRS) Network.
3. All data has been collected and processed using the Chesapeake Technologicize SonarWiz software package. The imagery has been collected and processed for towfish layback, bottom tracking, signal gain, and display quality to prepare a nearly seamless mosaic that is consistently illuminated from the west.
4. Horizontal positioning references the North American Datum of 1983 (NAD 1983) New York - Eastern Zone State Plane (feet).
5. Background aerial imagery is taken from the publicly available imagery via the ESRI online map servers and the 2016 digital aerial imagery available through the New York State Orthoimagery Program. The background baseplan drawing has been supplied by the client.



151 Martine Street, Suite 103
Fall River, MA 02723
Phone 508-250-0650
Fax 401-633-7113
<http://www.seavisionmarine.com>

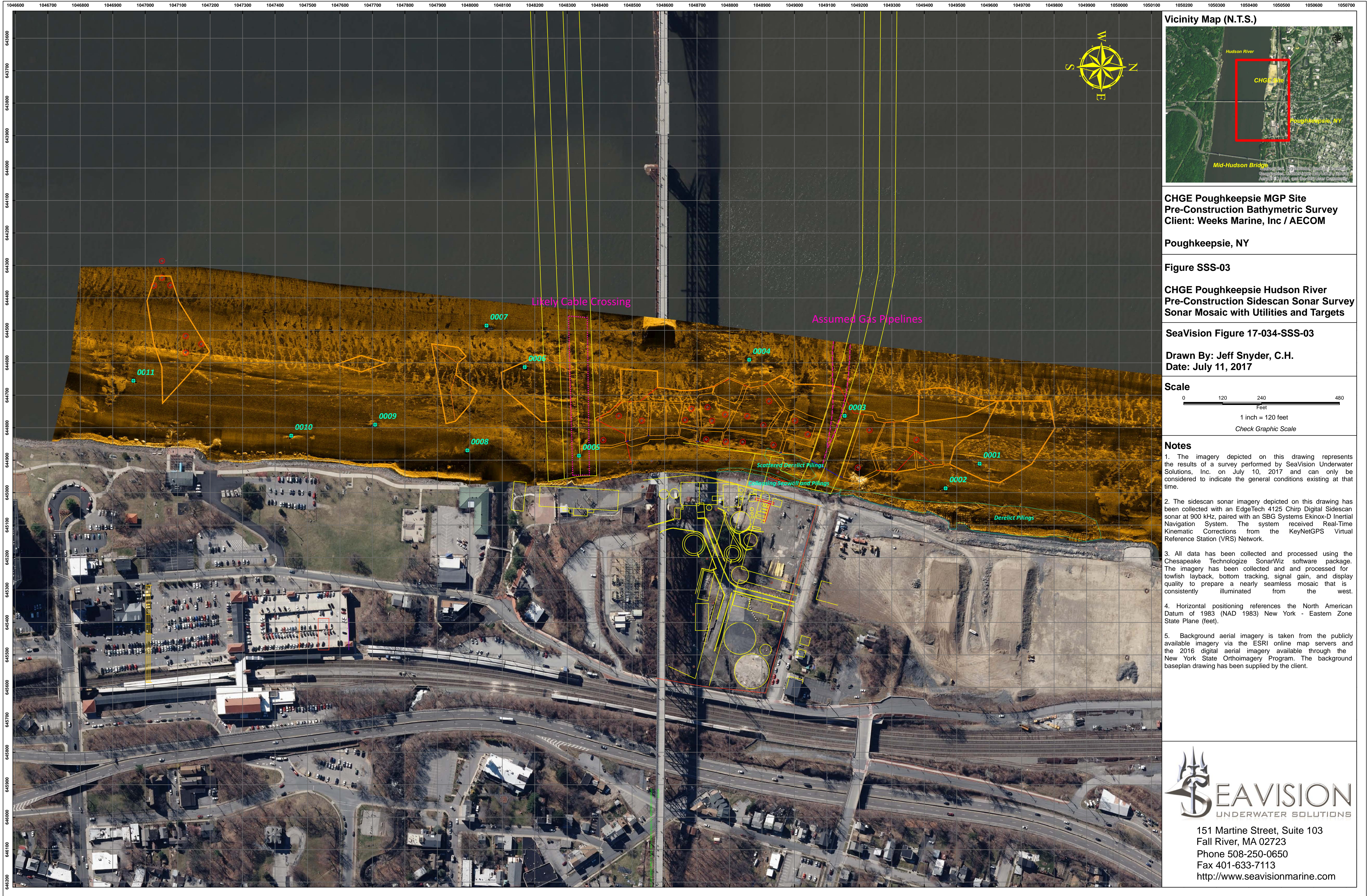

Vicinity Map (N.T.S.)

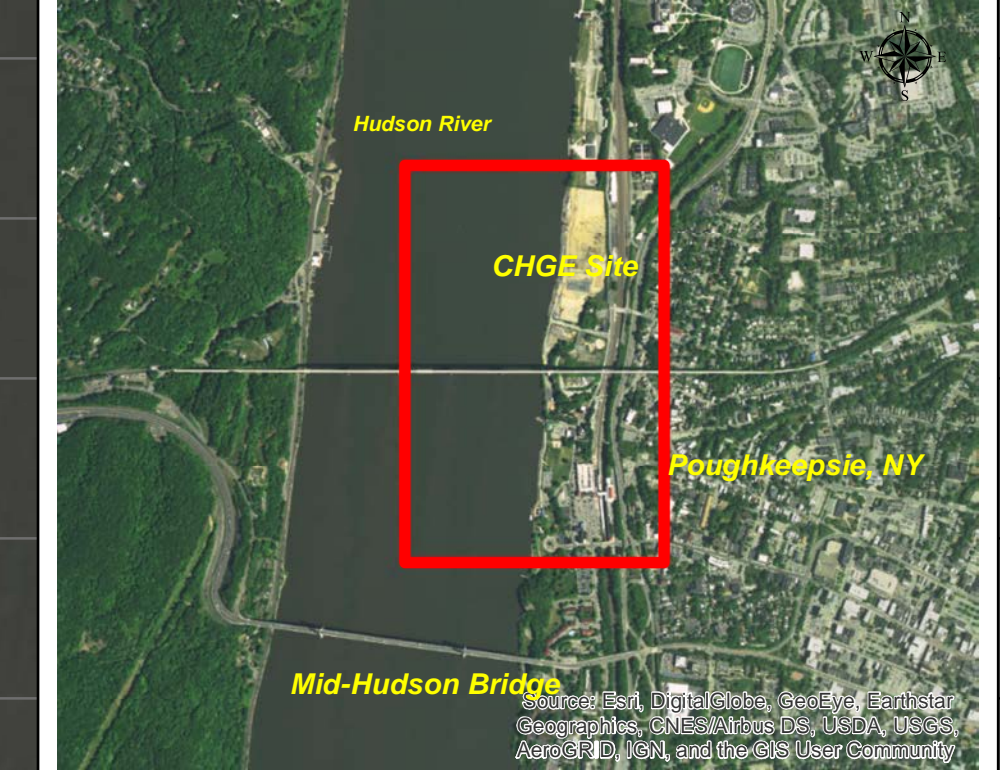

**CHGE Poughkeepsie MGP Site
Pre-Construction Bathymetric Survey
Client: Weeks Marine, Inc / AECOM**

Poughkeepsie, NY

Figure SSS-03

**CHGE Poughkeepsie Hudson River
Pre-Construction Sidescan Sonar Survey
Sonar Mosaic with Utilities and Targets**

SeaVision Figure 17-034-SSS-03

**Drawn By: Jeff Snyder, C.H.
Date: July 11, 2017**

Scale

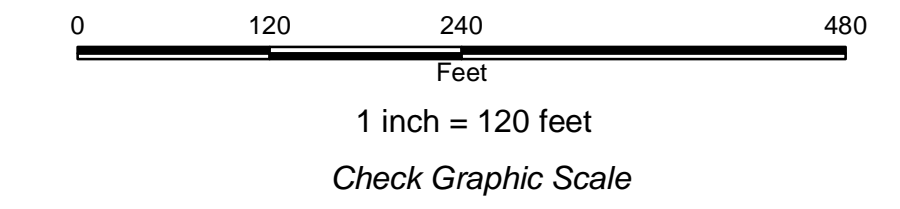

Notes

1. The imagery depicted on this drawing represents the results of a survey performed by SeaVision Underwater Solutions, Inc. on July 10, 2017 and can only be considered to indicate the general conditions existing at that time.
2. The sidescan sonar imagery depicted on this drawing has been collected with an EdgeTech 4125 Chirp Digital Sidescan sonar at 900 kHz, paired with an SBG Systems Ekinox-D Inertial Navigation System. The system received Real-Time Kinematic Corrections from the KeyNetGPS Virtual Reference Station (VRS) Network.
3. All data has been collected and processed using the Chesapeake Technologicize SonarWiz software package. The imagery has been collected and processed for towfish layback, bottom tracking, signal gain, and display quality to prepare a nearly seamless mosaic that is consistently illuminated from the west.
4. Horizontal positioning references the North American Datum of 1983 (NAD 1983) New York - Eastern Zone State Plane (feet).
5. Background aerial imagery is taken from the publicly available imagery via the ESRI online map servers and the 2016 digital aerial imagery available through the New York State Orthoimagery Program. The background baseplan drawing has been supplied by the client.



151 Martine Street, Suite 103
Fall River, MA 02723
Phone 508-250-0650
Fax 401-633-7113
<http://www.seavisionmarine.com>

CHGE Poughkeepsie SSS Target Report

Generated on 7/11/2017 11:01:50 PM

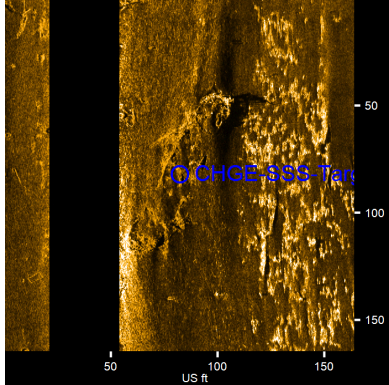
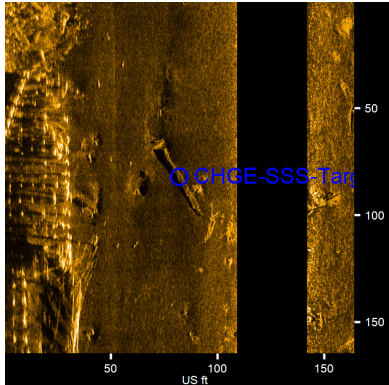
Target Image	Target Info	User Entered Info
	<p>CHGE-SSS-Target-0001</p> <ul style="list-style-type: none"> Click Position 41° 42.79758" N 073° 56.42178" W (WGS84) (X) 644911.19 (Y) 1049571.05 (Projected Coordinates) Map Projection: NY83-EF Water Depth: 13.58 US ft 	<p>Dimensions and attributes</p> <ul style="list-style-type: none"> Target Width: 13.22 US ft Target Height: 8.69 US ft Target Length: 85.35 US ft Target Shadow: 19.42 US ft Classification1: Possible wreck Description: Partially buried
	<p>CHGE-SSS-Target-0002</p> <ul style="list-style-type: none"> Click Position 41° 42.78025" N 073° 56.40532" W (WGS84) (X) 644986.77 (Y) 1049466.24 (Projected Coordinates) Map Projection: NY83-EF Water Depth: 13.47 US ft 	<p>Dimensions and attributes</p> <ul style="list-style-type: none"> Target Width: 2.89 US ft Target Height: 2.24 US ft Target Length: 34.36 US ft Target Shadow: 3.88 US ft Classification1: debris Description:

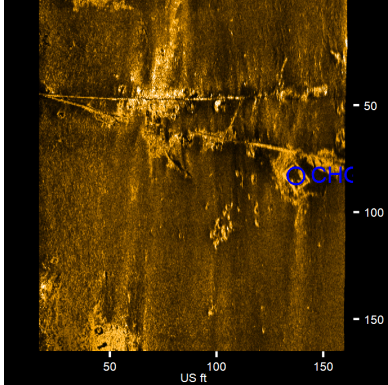
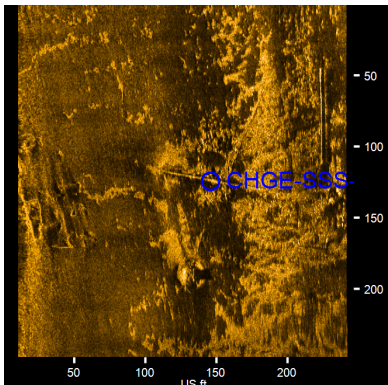
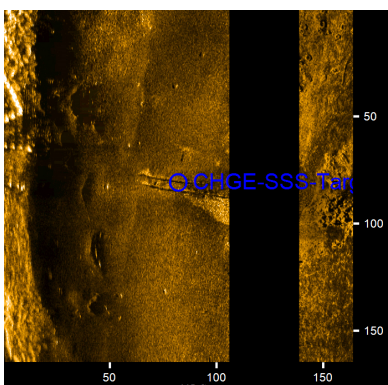
 <p>CHGE-SSS-Target-0003</p> <p>Click Position 41° 42.72930" N 073° 56.45474" W (WGS84) (X) 644763.88 (Y) 1049155.38 (Projected Coordinates)</p> <p>Map Projection: NY83-EF Water Depth: 13.54 US ft</p>	<p>CHGE-SSS-Target-0003</p> <ul style="list-style-type: none"> Click Position 41° 42.72930" N 073° 56.45474" W (WGS84) (X) 644763.88 (Y) 1049155.38 (Projected Coordinates) Map Projection: NY83-EF Water Depth: 13.54 US ft 	<p>Dimensions and attributes</p> <ul style="list-style-type: none"> Target Width: 14.23 US ft Target Height: 2.98 US ft Target Length: 14.77 US ft Target Shadow: 12.93 US ft Classification1: Debris Description: Unknown rectangular target adjacent to gas pipeline.
 <p>CHGE-SSS-Target-0004</p> <p>Click Position 41° 42.68097" N 073° 56.49319" W (WGS84) (X) 644590.83 (Y) 1048860.76 (Projected Coordinates)</p> <p>Map Projection: NY83-EF Water Depth: 11.76 US ft</p>	<p>CHGE-SSS-Target-0004</p> <ul style="list-style-type: none"> Click Position 41° 42.68097" N 073° 56.49319" W (WGS84) (X) 644590.83 (Y) 1048860.76 (Projected Coordinates) Map Projection: NY83-EF Water Depth: 11.76 US ft 	<p>Dimensions and attributes</p> <ul style="list-style-type: none"> Target Width: 1.64 US ft Target Height: 1.31 US ft Target Length: 86.74 US ft Target Shadow: 4.11 US ft Classification1: Unknown Description: Long straight object.
 <p>CHGE-SSS-Target-0005</p> <p>Click Position 41° 42.59434" N 073° 56.42896" W (WGS84) (X) 644886.53 (Y) 1048336.58 (Projected Coordinates)</p> <p>Map Projection: NY83-EF Water Depth: 13.67 US ft</p>	<p>CHGE-SSS-Target-0005</p> <ul style="list-style-type: none"> Click Position 41° 42.59434" N 073° 56.42896" W (WGS84) (X) 644886.53 (Y) 1048336.58 (Projected Coordinates) Map Projection: NY83-EF Water Depth: 13.67 US ft 	<p>Dimensions and attributes</p> <ul style="list-style-type: none"> Target Width: 1.04 US ft Target Height: 0.13 US ft Target Length: 41.14 US ft Target Shadow: 0.26 US ft Classification1: cables Description: Power cables, exposed on river bottom.

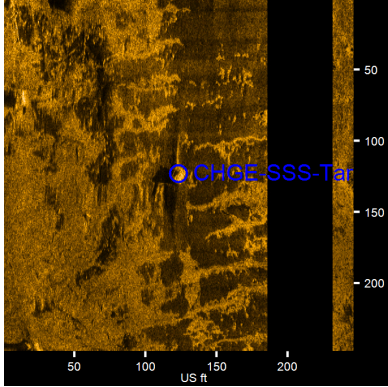
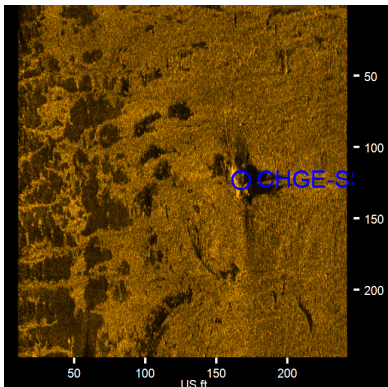
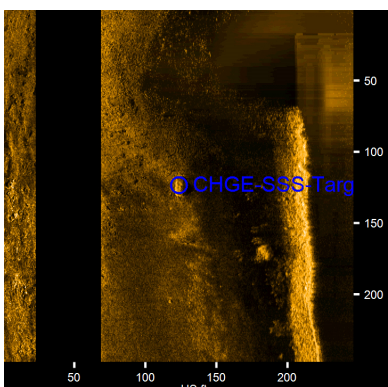
	<p>CHGE-SSS-Target-0006</p> <ul style="list-style-type: none"> Click Position 41° 42.56710" N 073° 56.48926" W (WGS84) (X) 644613.24 (Y) 1048169.41 (Projected Coordinates) Map Projection: NY83-EF Water Depth: 12.41 US ft 	<p>Dimensions and attributes</p> <ul style="list-style-type: none"> Target Width: 10.34 US ft Target Height: 5.91 US ft Target Length: 13.91 US ft Target Shadow: 14.32 US ft Classification1: Unknown Description:
	<p>CHGE-SSS-Target-0007</p> <ul style="list-style-type: none"> Click Position 41° 42.54783" N 073° 56.51752" W (WGS84) (X) 644485.37 (Y) 1048051.55 (Projected Coordinates) Map Projection: NY83-EF Water Depth: 11.65 US ft 	<p>Dimensions and attributes</p> <ul style="list-style-type: none"> Target Width: 9.72 US ft Target Height: 6.39 US ft Target Length: 23.12 US ft Target Shadow: 27.36 US ft Classification1: debris Description: Unknown object.
	<p>CHGE-SSS-Target-0008</p> <ul style="list-style-type: none"> Click Position 41° 42.53767" N 073° 56.43312" W (WGS84) (X) 644869.82 (Y) 1047992.32 (Projected Coordinates) Map Projection: NY83-EF Water Depth: 12.06 US ft 	<p>Dimensions and attributes</p> <ul style="list-style-type: none"> Target Width: 6.41 US ft Target Height: 3.03 US ft Target Length: 14.59 US ft Target Shadow: 8.99 US ft Classification1: car Description:

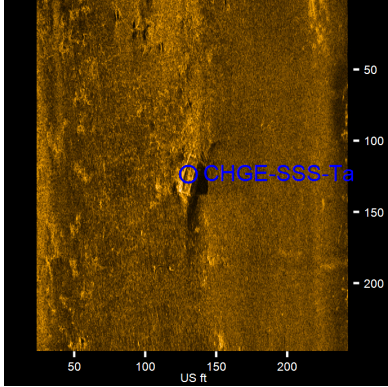
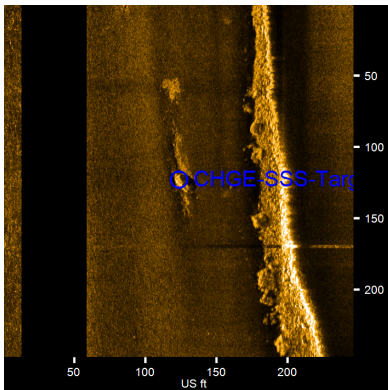
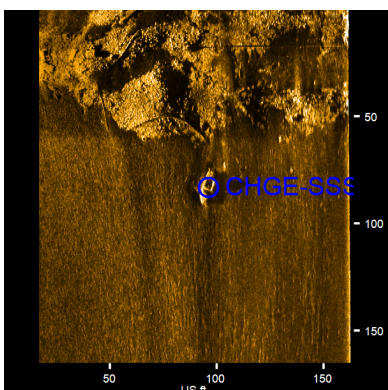
 <p>CHGE-SSS-Target-0009</p> <p>Click Position 41° 42.49104" N 073° 56.45088" W (WGS84) (X) 644790.88 (Y) 1047708.68 (Projected Coordinates)</p> <p>Map Projection: NY83-EF Water Depth: 12.01 US ft</p>	<p>CHGE-SSS-Target-0009</p> <ul style="list-style-type: none"> Click Position 41° 42.49104" N 073° 56.45088" W (WGS84) (X) 644790.88 (Y) 1047708.68 (Projected Coordinates) Map Projection: NY83-EF Water Depth: 12.01 US ft 	<p>Dimensions and attributes</p> <ul style="list-style-type: none"> Target Width: 8.17 US ft Target Height: 2.83 US ft Target Length: 27.81 US ft Target Shadow: 9.52 US ft Classification1: debris Description: Unknown rectangular object.
 <p>CHGE-SSS-Target-0010</p> <p>Click Position 41° 42.44842" N 073° 56.44380" W (WGS84) (X) 644824.75 (Y) 1047450.02 (Projected Coordinates)</p> <p>Map Projection: NY83-EF Water Depth: 12.12 US ft</p>	<p>CHGE-SSS-Target-0010</p> <ul style="list-style-type: none"> Click Position 41° 42.44842" N 073° 56.44380" W (WGS84) (X) 644824.75 (Y) 1047450.02 (Projected Coordinates) Map Projection: NY83-EF Water Depth: 12.12 US ft 	<p>Dimensions and attributes</p> <ul style="list-style-type: none"> Target Width: 4.93 US ft Target Height: 2.47 US ft Target Length: 12.79 US ft Target Shadow: 8.09 US ft Classification1: car Description:
 <p>CHGE-SSS-Target-0011</p> <p>Click Position 41° 42.36850" N 073° 56.48161" W (WGS84) (X) 644655.87 (Y) 1046963.59 (Projected Coordinates)</p> <p>Map Projection: NY83-EF Water Depth: 11.95 US ft</p>	<p>CHGE-SSS-Target-0011</p> <ul style="list-style-type: none"> Click Position 41° 42.36850" N 073° 56.48161" W (WGS84) (X) 644655.87 (Y) 1046963.59 (Projected Coordinates) Map Projection: NY83-EF Water Depth: 11.95 US ft 	<p>Dimensions and attributes</p> <ul style="list-style-type: none"> Target Width: 5.51 US ft Target Height: 4.13 US ft Target Length: 16.28 US ft Target Shadow: 18.81 US ft Classification1: boat Description:

Appendix G

Pre Design Investigation Community Air Monitoring Report Results

E-Format Only

Instrument Name	DustTrak II
Model Number	8530
Serial Number	8530113113
Firmware Version	3.4
Calibration Date	7/12/2016
Test Name	MANUAL_001
Test Start Time	10:27:02 AM
Test Start Date	6/12/2017
Test Length [D:H:M]	0:20:36
Test Interval [M:S]	1:00
Mass Average [mg/m3]	-0.023
Mass Minimum [mg/m3]	-0.116
Mass Maximum [mg/m3]	1.27
Mass TWA [mg/m3]	-0.015
Photometric User Cal	1
Flow User Cal	0
Errors	
Number of Samples	322

Elapsed Time [s]	Mass [mg/m3]	Alarms	Errors
60	0.065		
120	0.102		
180	0.896		
240	0.943		
300	1.27		
360	1.22		
420	0.853		
480	0.056		
540	0.054		
600	0.052		
660	0.051		
720	0.049		
780	0.053		
840	0.055		
900	0.054		
960	0.071		
1020	0.063		
1080	0.059		
1140	0.054		
1200	0.052		
1260	0.054		
1320	0.062		
1380	0.053		
1440	0.058		
1500	0.051		
1560	0.049		
1620	0.052		

Elapsed Time [s]	Mass [mg/m3]	Alarms	Errors
1680	0.052		
1740	0.061		
1800	0.055		
1860	0.053		
1920	0.051		
1980	0.055		
2040	0.065		
2100	0.118		
2160	0.078		
2220	0.147		
2280	0.059		
2340	0.071		
2400	0.073		
2460	0.07		
2520	0.085		
2580	0.064		
2640	0.089		
2700	0.062		
2760	0.066		
2820	0.064		
2880	0.065		
2940	0.061		
3000	0.076		
3060	0.071		
3120	0.068		
3180	0.09		
3240	0.074		
3300	0.072		
3360	0.067		
3420	0.067		
3480	0.077		
3540	0.067		
3600	0.058		
3660	0.026		
3720	0.038		
3780	0.005		
3840	0.011		
3900	0.013		
3960	0.012		
4020	0.021		
4080	0.011		
4140	0.012		
4200	0.012		
4260	0.005		
4320	0.01		
4380	0.004		

Elapsed Time [s]	Mass [mg/m3]	Alarms	Errors
4440	0.005		
4500	0.009		
4560	0.005		
4620	0.002		
4680	-0.002		
4740	0		
4800	-0.002		
4860	0		
4920	0		
4980	-0.001		
5040	-0.003		
5100	-0.007		
5160	-0.004		
5220	-0.002		
5280	0		
5340	-0.003		
5400	-0.007		
5460	-0.011		
5520	-0.01		
5580	-0.013		
5640	-0.011		
5700	-0.013		
5760	-0.01		
5820	-0.007		
5880	-0.011		
5940	-0.011		
6000	-0.018		
6060	-0.014		
6120	-0.015		
6180	-0.016		
6240	-0.023		
6300	-0.026		
6360	-0.022		
6420	-0.017		
6480	-0.019		
6540	-0.024		
6600	-0.026		
6660	-0.02		
6720	-0.019		
6780	-0.021		
6840	-0.022		
6900	-0.02		
6960	-0.023		
7020	-0.03		
7080	-0.024		
7140	-0.034		

Elapsed Time [s]	Mass [mg/m3]	Alarms	Errors
7200	-0.026		
7260	-0.03		
7320	-0.027		
7380	-0.03		
7440	-0.03		
7500	-0.022		
7560	-0.024		
7620	-0.03		
7680	-0.028		
7740	-0.03		
7800	-0.03		
7860	-0.036		
7920	-0.033		
7980	-0.036		
8040	-0.036		
8100	-0.045		
8160	-0.04		
8220	-0.044		
8280	-0.043		
8340	-0.041		
8400	-0.049		
8460	-0.057		
8520	0.017		
8580	-0.057		
8640	-0.057		
8700	-0.059		
8760	-0.059		
8820	-0.06		
8880	-0.06		
8940	-0.061		
9000	-0.062		
9060	-0.061		
9120	-0.062		
9180	-0.062		
9240	-0.064		
9300	-0.065		
9360	-0.066		
9420	-0.066		
9480	-0.065		
9540	-0.067		
9600	-0.067		
9660	-0.067		
9720	-0.066		
9780	-0.068		
9840	-0.068		
9900	-0.069		

Elapsed Time [s]	Mass [mg/m3]	Alarms	Errors
9960	-0.067		
10020	-0.067		
10080	-0.068		
10140	-0.068		
10200	-0.07		
10260	-0.071		
10320	-0.071		
10380	-0.071		
10440	-0.071		
10500	-0.071		
10560	-0.071		
10620	-0.071		
10680	-0.072		
10740	-0.042		
10800	-0.072		
10860	-0.071		
10920	-0.059		
10980	-0.074		
11040	-0.074		
11100	-0.075		
11160	-0.053		
11220	-0.06		
11280	-0.074		
11340	-0.057		
11400	-0.067		
11460	-0.07		
11520	-0.074		
11580	-0.071		
11640	-0.077		
11700	-0.079		
11760	-0.078		
11820	-0.081		
11880	-0.079		
11940	-0.079		
12000	-0.077		
12060	-0.076		
12120	-0.078		
12180	-0.08		
12240	-0.081		
12300	-0.082		
12360	-0.081		
12420	-0.081		
12480	-0.08		
12540	-0.081		
12600	-0.082		
12660	-0.082		

Elapsed Time [s]	Mass [mg/m3]	Alarms	Errors
12720	-0.082		
12780	-0.08		
12840	-0.077		
12900	-0.05		
12960	-0.083		
13020	-0.084		
13080	-0.082		
13140	-0.082		
13200	-0.08		
13260	-0.084		
13320	-0.081		
13380	-0.082		
13440	-0.081		
13500	-0.085		
13560	-0.085		
13620	-0.087		
13680	-0.023		
13740	-0.059		
13800	-0.074		
13860	-0.085		
13920	-0.078		
13980	-0.066		
14040	-0.089		
14100	-0.088		
14160	-0.091		
14220	-0.091		
14280	-0.089		
14340	-0.091		
14400	-0.087		
14460	-0.084		
14520	-0.089		
14580	-0.085		
14640	-0.091		
14700	-0.09		
14760	-0.093		
14820	-0.092		
14880	-0.091		
14940	-0.089		
15000	-0.092		
15060	-0.093		
15120	-0.09		
15180	-0.091		
15240	-0.09		
15300	-0.093		
15360	-0.093		
15420	-0.087		

Elapsed Time [s]	Mass [mg/m3]	Alarms	Errors
15480	-0.093		
15540	-0.092		
15600	-0.093		
15660	-0.094		
15720	-0.092		
15780	-0.095		
15840	-0.093		
15900	-0.093		
15960	-0.095		
16020	-0.09		
16080	-0.09		
16140	-0.093		
16200	-0.093		
16260	-0.092		
16320	-0.095		
16380	-0.096		
16440	-0.1		
16500	-0.098		
16560	-0.098		
16620	-0.097		
16680	-0.094		
16740	-0.097		
16800	-0.098		
16860	-0.098		
16920	-0.099		
16980	-0.099		
17040	-0.1		
17100	-0.094		
17160	-0.098		
17220	-0.103		
17280	-0.104		
17340	-0.106		
17400	-0.109		
17460	-0.111		
17520	-0.109		
17580	-0.102		
17640	-0.103		
17700	-0.071		
17760	-0.028		
17820	-0.092		
17880	-0.112		
17940	-0.112		
18000	-0.107		
18060	-0.11		
18120	-0.114		
18180	-0.113		

Elapsed Time [s]	Mass [mg/m3]	Alarms	Errors
18240	-0.114		
18300	-0.107		
18360	-0.115		
18420	-0.114		
18480	-0.114		
18540	-0.114		
18600	-0.114		
18660	-0.114		
18720	-0.116		
18780	-0.114		
18840	-0.114		
18900	-0.055		
18960	-0.114		
19020	-0.115		
19080	-0.114		
19140	-0.113		
19200	-0.115		
19260	-0.114		
74216	0		

Instrument Name	DustTrak II
Model Number	8530
Serial Number	8530123517
Firmware Version	3.4
Calibration Date	5/29/2014
Test Name	MANUAL_001
Test Start Time	10:31:56 AM
Test Start Date	6/12/2017
Test Length [D:H:M]	0:20:33
Test Interval [M:S]	1:00
Mass Average [mg/m3]	-0.053
Mass Minimum [mg/m3]	-0.09
Mass Maximum [mg/m3]	0.083
Mass TWA [mg/m3]	-0.034
Photometric User Cal	0.9
Flow User Cal	0
Errors	
Number of Samples	313

Elapsed Time [s]	Mass [mg/m3]	Alarms	Errors
60	0.035		
120	0.031		
180	0.029		
240	0.026		
300	0.012		
360	0.007		
420	0.014		
480	0.012		
540	0.013		
600	0.014		
660	0.009		
720	0.014		
780	0.013		
840	0.01		
900	0.01		
960	0.01		
1020	0.009		
1080	0.006		
1140	0.004		
1200	0.004		
1260	0.003		
1320	0.001		
1380	0.001		
1440	0		
1500	0		
1560	0		
1620	-0.001		

Elapsed Time [s]	Mass [mg/m3]	Alarms	Errors
1680	-0.002		
1740	0.083		
1800	0.004		
1860	-0.002		
1920	-0.003		
1980	-0.006		
2040	-0.006		
2100	-0.006		
2160	-0.007		
2220	-0.007		
2280	-0.005		
2340	-0.004		
2400	-0.005		
2460	-0.007		
2520	-0.007		
2580	-0.009		
2640	-0.009		
2700	-0.01		
2760	-0.011		
2820	-0.012		
2880	-0.012		
2940	-0.013		
3000	-0.014		
3060	-0.016		
3120	-0.017		
3180	-0.018		
3240	-0.02		
3300	-0.022		
3360	-0.023		
3420	-0.026		
3480	-0.027		
3540	-0.029		
3600	-0.03		
3660	-0.027		
3720	-0.032		
3780	-0.033		
3840	-0.038		
3900	-0.04		
3960	-0.041		
4020	-0.042		
4080	-0.043		
4140	-0.045		
4200	-0.047		
4260	-0.055		
4320	-0.056		
4380	-0.053		

Elapsed Time [s]	Mass [mg/m3]	Alarms	Errors
4440	-0.05		
4500	-0.05		
4560	-0.051		
4620	-0.051		
4680	-0.053		
4740	-0.053		
4800	-0.054		
4860	-0.056		
4920	-0.056		
4980	-0.057		
5040	-0.058		
5100	-0.058		
5160	-0.058		
5220	-0.06		
5280	-0.06		
5340	-0.061		
5400	-0.063		
5460	-0.064		
5520	-0.065		
5580	-0.064		
5640	-0.063		
5700	-0.063		
5760	-0.063		
5820	-0.064		
5880	-0.065		
5940	-0.066		
6000	-0.067		
6060	-0.068		
6120	-0.069		
6180	-0.069		
6240	-0.076		
6300	-0.073		
6360	-0.07		
6420	-0.069		
6480	-0.069		
6540	-0.068		
6600	-0.069		
6660	-0.069		
6720	-0.07		
6780	-0.069		
6840	-0.07		
6900	-0.068		
6960	-0.07		
7020	-0.07		
7080	-0.071		
7140	-0.072		

Elapsed Time [s]	Mass [mg/m3]	Alarms	Errors
7200	-0.072		
7260	-0.072		
7320	-0.072		
7380	-0.073		
7440	-0.073		
7500	-0.074		
7560	-0.075		
7620	-0.075		
7680	-0.075		
7740	-0.076		
7800	-0.076		
7860	-0.077		
7920	-0.078		
7980	-0.078		
8040	-0.078		
8100	-0.079		
8160	-0.09		
8220	-0.073		
8280	-0.073		
8340	-0.072		
8400	-0.072		
8460	-0.073		
8520	-0.073		
8580	-0.074		
8640	-0.078		
8700	-0.079		
8760	-0.081		
8820	-0.085		
8880	-0.083		
8940	-0.081		
9000	-0.083		
9060	-0.082		
9120	-0.083		
9180	-0.085		
9240	-0.085		
9300	-0.085		
9360	-0.085		
9420	-0.086		
9480	-0.085		
9540	-0.087		
9600	-0.087		
9660	-0.09		
9720	-0.086		
9780	-0.085		
9840	-0.084		
9900	-0.084		

Elapsed Time [s]	Mass [mg/m3]	Alarms	Errors
9960	-0.085		
10020	-0.082		
10080	-0.08		
10140	-0.082		
10200	-0.083		
10260	-0.077		
10320	-0.087		
10380	-0.083		
10440	-0.086		
10500	-0.075		
10560	-0.073		
10620	-0.087		
10680	-0.081		
10740	-0.074		
10800	-0.084		
10860	-0.073		
10920	-0.078		
10980	-0.074		
11040	-0.074		
11100	-0.079		
11160	-0.077		
11220	-0.079		
11280	-0.081		
11340	-0.081		
11400	-0.077		
11460	-0.077		
11520	-0.076		
11580	-0.069		
11640	-0.066		
11700	-0.065		
11760	-0.065		
11820	-0.064		
11880	-0.064		
11940	-0.064		
12000	-0.065		
12060	-0.066		
12120	-0.065		
12180	-0.064		
12240	-0.063		
12300	-0.062		
12360	-0.061		
12420	-0.061		
12480	-0.062		
12540	-0.063		
12600	-0.062		
12660	-0.061		

Elapsed Time [s]	Mass [mg/m3]	Alarms	Errors
12720	-0.061		
12780	-0.061		
12840	-0.061		
12900	-0.061		
12960	-0.061		
13020	-0.061		
13080	-0.06		
13140	-0.06		
13200	-0.06		
13260	-0.06		
13320	-0.059		
13380	-0.059		
13440	-0.059		
13500	-0.06		
13560	-0.06		
13620	-0.06		
13680	-0.06		
13740	-0.06		
13800	-0.062		
13860	-0.062		
13920	-0.062		
13980	-0.061		
14040	-0.06		
14100	-0.06		
14160	-0.06		
14220	-0.059		
14280	-0.059		
14340	-0.059		
14400	-0.059		
14460	-0.06		
14520	-0.063		
14580	-0.063		
14640	-0.063		
14700	-0.063		
14760	-0.064		
14820	-0.063		
14880	-0.063		
14940	-0.064		
15000	-0.063		
15060	-0.063		
15120	-0.064		
15180	-0.067		
15240	-0.064		
15300	-0.062		
15360	-0.063		
15420	-0.063		

Elapsed Time [s]	Mass [mg/m3]	Alarms	Errors
15480	-0.062		
15540	-0.062		
15600	-0.062		
15660	-0.062		
15720	-0.061		
15780	-0.061		
15840	-0.061		
15900	-0.061		
15960	-0.061		
16020	-0.061		
16080	-0.061		
16140	-0.061		
16200	-0.06		
16260	-0.059		
16320	-0.06		
16380	-0.06		
16440	-0.06		
16500	-0.06		
16560	-0.06		
16620	-0.059		
16680	-0.058		
16740	-0.059		
16800	-0.062		
16860	-0.062		
16920	-0.061		
16980	-0.062		
17040	-0.061		
17100	-0.059		
17160	-0.058		
17220	-0.058		
17280	-0.06		
17340	-0.06		
17400	-0.034		
17460	-0.058		
17520	-0.058		
17580	-0.058		
17640	-0.058		
17700	-0.06		
17760	-0.059		
17820	-0.059		
17880	-0.057		
17940	-0.059		
18000	-0.059		
18060	-0.059		
18120	-0.057		
18180	-0.058		

Elapsed Time [s]	Mass [mg/m3]	Alarms	Errors
18240	-0.057		
18300	-0.057		
18360	-0.058		
18420	-0.057		
18480	-0.057		
18540	-0.058		
18600	-0.058		
18660	-0.057		
18720	-0.056		
74029	0		

Instrument Name	DustTrak II
Model Number	8530
Serial Number	8530113113
Firmware Version	3.4
Calibration Date	7/12/2016
Test Name	MANUAL_002
Test Start Time	7:04:08 AM
Test Start Date	6/13/2017
Test Length [D:H:M]	0:07:44
Test Interval [M:S]	1:00
Mass Average [mg/m3]	-0.018
Mass Minimum [mg/m3]	-0.115
Mass Maximum [mg/m3]	0.367
Mass TWA [mg/m3]	-0.017
Photometric User Cal	1
Flow User Cal	0
Errors	
Number of Samples	464

Elapsed Time [s]	Mass [mg/m3]	Alarms	Errors
60	0.07		
120	0.071		
180	0.069		
240	0.069		
300	0.069		
360	0.069		
420	0.069		
480	0.069		
540	0.069		
600	0.069		
660	0.068		
720	0.067		
780	0.068		
840	0.068		
900	0.068		
960	0.068		
1020	0.069		
1080	0.069		
1140	0.069		
1200	0.068		
1260	0.07		
1320	0.069		
1380	0.069		
1440	0.07		
1500	0.07		
1560	0.068		
1620	0.069		

Elapsed Time [s]	Mass [mg/m3]	Alarms	Errors
1680	0.068		
1740	0.068		
1800	0.068		
1860	0.068		
1920	0.068		
1980	0.067		
2040	0.067		
2100	0.067		
2160	0.067		
2220	0.066		
2280	0.066		
2340	0.066		
2400	0.083		
2460	0.066		
2520	0.065		
2580	0.066		
2640	0.066		
2700	0.066		
2760	0.067		
2820	0.065		
2880	0.064		
2940	0.064		
3000	0.064		
3060	0.066		
3120	0.063		
3180	0.067		
3240	0.063		
3300	0.064		
3360	0.063		
3420	0.062		
3480	0.062		
3540	0.071		
3600	0.064		
3660	0.061		
3720	0.068		
3780	0.073		
3840	0.074		
3900	0.061		
3960	0.061		
4020	0.06		
4080	0.064		
4140	0.063		
4200	0.065		
4260	0.06		
4320	0.06		
4380	0.06		

Elapsed Time [s]	Mass [mg/m3]	Alarms	Errors
4440	0.06		
4500	0.062		
4560	0.065		
4620	0.063		
4680	0.062		
4740	0.064		
4800	0.065		
4860	0.059		
4920	0.058		
4980	0.058		
5040	0.06		
5100	0.061		
5160	0.068		
5220	0.058		
5280	0.057		
5340	0.058		
5400	0.058		
5460	0.058		
5520	0.057		
5580	0.058		
5640	0.058		
5700	0.061		
5760	0.06		
5820	0.07		
5880	0.06		
5940	0.06		
6000	0.07		
6060	0.062		
6120	0.062		
6180	0.058		
6240	0.367		
6300	0.06		
6360	0.059		
6420	0.059		
6480	0.059		
6540	0.057		
6600	0.057		
6660	0.061		
6720	0.128		
6780	0.072		
6840	0.055		
6900	0.055		
6960	0.055		
7020	0.056		
7080	0.055		
7140	0.056		

Elapsed Time [s]	Mass [mg/m3]	Alarms	Errors
7200	0.056		
7260	0.055		
7320	0.055		
7380	0.056		
7440	0.057		
7500	0.056		
7560	0.058		
7620	0.061		
7680	0.072		
7740	0.059		
7800	0.06		
7860	0.057		
7920	0.058		
7980	0.058		
8040	0.056		
8100	0.056		
8160	0.057		
8220	0.054		
8280	0.055		
8340	0.055		
8400	0.055		
8460	0.056		
8520	0.057		
8580	0.055		
8640	0.054		
8700	0.054		
8760	0.055		
8820	0.055		
8880	0.056		
8940	0.055		
9000	0.054		
9060	0.047		
9120	0.004		
9180	0.002		
9240	0		
9300	0		
9360	0.005		
9420	0		
9480	0		
9540	-0.001		
9600	-0.002		
9660	-0.003		
9720	-0.003		
9780	-0.005		
9840	-0.008		
9900	-0.007		

Elapsed Time [s]	Mass [mg/m3]	Alarms	Errors
9960	-0.005		
10020	-0.009		
10080	0.003		
10140	-0.005		
10200	-0.008		
10260	-0.006		
10320	-0.008		
10380	-0.008		
10440	-0.009		
10500	-0.009		
10560	-0.008		
10620	-0.007		
10680	-0.008		
10740	-0.009		
10800	-0.01		
10860	-0.01		
10920	-0.012		
10980	-0.013		
11040	-0.006		
11100	-0.012		
11160	-0.013		
11220	-0.014		
11280	-0.015		
11340	-0.015		
11400	-0.016		
11460	-0.016		
11520	-0.016		
11580	-0.019		
11640	-0.015		
11700	-0.007		
11760	-0.017		
11820	-0.018		
11880	-0.016		
11940	-0.016		
12000	-0.017		
12060	-0.017		
12120	-0.017		
12180	-0.016		
12240	-0.02		
12300	-0.022		
12360	-0.023		
12420	-0.021		
12480	-0.022		
12540	-0.025		
12600	-0.028		
12660	-0.028		

Elapsed Time [s]	Mass [mg/m3]	Alarms	Errors
12720	-0.023		
12780	-0.028		
12840	-0.029		
12900	-0.027		
12960	-0.028		
13020	-0.027		
13080	-0.03		
13140	-0.03		
13200	-0.03		
13260	-0.031		
13320	-0.031		
13380	-0.028		
13440	-0.031		
13500	-0.027		
13560	-0.032		
13620	-0.029		
13680	-0.032		
13740	-0.032		
13800	-0.029		
13860	-0.024		
13920	-0.024		
13980	-0.033		
14040	-0.018		
14100	-0.023		
14160	-0.033		
14220	-0.033		
14280	-0.034		
14340	-0.037		
14400	-0.025		
14460	-0.031		
14520	-0.033		
14580	-0.029		
14640	-0.03		
14700	-0.034		
14760	-0.037		
14820	-0.037		
14880	-0.037		
14940	-0.037		
15000	-0.036		
15060	0.308		
15120	-0.018		
15180	-0.025		
15240	-0.016		
15300	-0.024		
15360	-0.036		
15420	-0.036		

Elapsed Time [s]	Mass [mg/m3]	Alarms	Errors
15480	-0.041		
15540	-0.039		
15600	-0.035		
15660	-0.037		
15720	-0.04		
15780	-0.037		
15840	-0.035		
15900	-0.036		
15960	-0.034		
16020	-0.037		
16080	-0.038		
16140	-0.041		
16200	-0.035		
16260	-0.041		
16320	-0.039		
16380	-0.041		
16440	-0.04		
16500	-0.042		
16560	-0.034		
16620	-0.044		
16680	-0.048		
16740	-0.045		
16800	-0.047		
16860	-0.042		
16920	-0.043		
16980	-0.045		
17040	-0.043		
17100	-0.043		
17160	-0.045		
17220	-0.045		
17280	-0.045		
17340	-0.045		
17400	-0.048		
17460	-0.053		
17520	-0.051		
17580	-0.046		
17640	-0.056		
17700	-0.057		
17760	-0.058		
17820	-0.053		
17880	-0.056		
17940	-0.057		
18000	-0.054		
18060	-0.057		
18120	-0.054		
18180	-0.056		

Elapsed Time [s]	Mass [mg/m3]	Alarms	Errors
18240	-0.054		
18300	-0.053		
18360	-0.055		
18420	-0.056		
18480	-0.053		
18540	-0.053		
18600	-0.057		
18660	-0.064		
18720	-0.067		
18780	-0.064		
18840	-0.063		
18900	-0.062		
18960	-0.063		
19020	-0.067		
19080	-0.069		
19140	-0.07		
19200	-0.071		
19260	-0.071		
19320	-0.07		
19380	0		
19440	-0.077		
19500	-0.078		
19560	-0.079		
19620	-0.08		
19680	-0.08		
19740	-0.081		
19800	-0.081		
19860	-0.08		
19920	-0.082		
19980	-0.081		
20040	-0.08		
20100	-0.077		
20160	-0.077		
20220	-0.08		
20280	-0.082		
20340	-0.084		
20400	-0.087		
20460	-0.088		
20520	0.06		
20580	-0.088		
20640	0.159		
20700	-0.087		
20760	-0.09		
20820	-0.091		
20880	-0.093		
20940	-0.094		

Elapsed Time [s]	Mass [mg/m3]	Alarms	Errors
21000	-0.096		
21060	-0.097		
21120	-0.098		
21180	-0.099		
21240	-0.1		
21300	-0.1		
21360	-0.102		
21420	-0.103		
21480	-0.103		
21540	-0.104		
21600	-0.104		
21660	-0.105		
21720	-0.104		
21780	-0.105		
21840	-0.106		
21900	-0.106		
21960	-0.097		
22020	-0.101		
22080	-0.106		
22140	-0.106		
22200	-0.107		
22260	-0.109		
22320	-0.11		
22380	-0.109		
22440	-0.112		
22500	-0.112		
22560	-0.112		
22620	-0.114		
22680	-0.113		
22740	-0.111		
22800	-0.111		
22860	-0.113		
22920	-0.111		
22980	-0.113		
23040	-0.113		
23100	-0.113		
23160	-0.113		
23220	-0.113		
23280	-0.112		
23340	-0.113		
23400	-0.113		
23460	-0.112		
23520	-0.112		
23580	-0.112		
23640	-0.107		
23700	-0.113		

Elapsed Time [s]	Mass [mg/m3]	Alarms	Errors
23760	-0.113		
23820	-0.114		
23880	-0.114		
23940	-0.113		
24000	-0.113		
24060	-0.114		
24120	-0.113		
24180	-0.114		
24240	-0.111		
24300	-0.115		
24360	-0.115		
24420	-0.115		
24480	-0.114		
24540	-0.111		
24600	-0.11		
24660	-0.111		
24720	-0.11		
24780	-0.108		
24840	-0.108		
24900	-0.107		
24960	-0.105		
25020	-0.103		
25080	-0.106		
25140	-0.106		
25200	-0.106		
25260	-0.105		
25320	-0.104		
25380	-0.103		
25440	-0.103		
25500	-0.103		
25560	-0.103		
25620	-0.102		
25680	-0.101		
25740	-0.098		
25800	-0.103		
25860	-0.1		
25920	-0.1		
25980	-0.098		
26040	-0.099		
26100	-0.098		
26160	-0.097		
26220	-0.096		
26280	-0.094		
26340	-0.093		
26400	-0.088		
26460	-0.089		

Elapsed Time [s]	Mass [mg/m3]	Alarms	Errors
26520	-0.091		
26580	-0.087		
26640	-0.09		
26700	-0.089		
26760	-0.088		
26820	-0.086		
26880	-0.085		
26940	-0.084		
27000	-0.084		
27060	-0.084		
27120	-0.082		
27180	-0.082		
27240	-0.078		
27300	-0.072		
27360	-0.076		
27420	-0.077		
27480	-0.07		
27540	-0.072		
27600	-0.074		
27660	-0.04		
27720	0.01		
27780	-0.031		
27840	-0.063		

Instrument Name	DustTrak II
Model Number	8530
Serial Number	8530113113
Firmware Version	3.4
Calibration Date	7/12/2016
Test Name	MANUAL_003
Test Start Time	10:17:06 AM
Test Start Date	6/14/2017
Test Length [D:H:M]	0:05:44
Test Interval [M:S]	1:00
Mass Average [mg/m3]	-0.07
Mass Minimum [mg/m3]	-0.136
Mass Maximum [mg/m3]	0.038
Mass TWA [mg/m3]	-0.05
Photometric User Cal	1
Flow User Cal	0
Errors	
Number of Samples	344

Elapsed Time [s]	Mass [mg/m3]	Alarms	Errors
60	0.013		
120	0.012		
180	0.01		
240	0.011		
300	0.01		
360	0.009		
420	0.009		
480	0.009		
540	0.009		
600	0.009		
660	0.009		
720	0.009		
780	0.011		
840	0.009		
900	0.017		
960	0.01		
1020	0.009		
1080	0.01		
1140	0.01		
1200	0.011		
1260	0.011		
1320	0.01		
1380	0.017		
1440	0.038		
1500	0.011		
1560	0.009		
1620	0.009		

Elapsed Time [s]	Mass [mg/m3]	Alarms	Errors
1680	0.009		
1740	0.009		
1800	0.01		
1860	0.011		
1920	0.011		
1980	0.009		
2040	0.01		
2100	0.009		
2160	0.01		
2220	0.01		
2280	0.01		
2340	0.012		
2400	0.011		
2460	0.01		
2520	0.01		
2580	0.01		
2640	0.012		
2700	0.01		
2760	0.01		
2820	0.01		
2880	0.01		
2940	0.011		
3000	0.01		
3060	0.01		
3120	0.01		
3180	0.013		
3240	0.01		
3300	0.01		
3360	0.01		
3420	0.01		
3480	0.01		
3540	0.01		
3600	0.01		
3660	0.01		
3720	0.011		
3780	0.009		
3840	0.012		
3900	0.011		
3960	0.011		
4020	0.011		
4080	0.011		
4140	0.01		
4200	0.009		
4260	0.01		
4320	0.01		
4380	0.009		

Elapsed Time [s]	Mass [mg/m3]	Alarms	Errors
4440	0.01		
4500	0.011		
4560	0.011		
4620	0.013		
4680	0.012		
4740	0.011		
4800	0.011		
4860	0.011		
4920	0.011		
4980	0.011		
5040	0.014		
5100	0.01		
5160	0.01		
5220	0.01		
5280	0.011		
5340	0.011		
5400	0.01		
5460	0.01		
5520	0.011		
5580	0.011		
5640	0.01		
5700	0.011		
5760	0.013		
5820	0.012		
5880	0.01		
5940	0.01		
6000	0.014		
6060	0.009		
6120	0.01		
6180	0.01		
6240	0.01		
6300	0.007		
6360	0.01		
6420	0.011		
6480	0.011		
6540	0.011		
6600	0.011		
6660	0.011		
6720	0.011		
6780	-0.022		
6840	-0.031		
6900	-0.032		
6960	-0.03		
7020	-0.034		
7080	-0.034		
7140	-0.034		

Elapsed Time [s]	Mass [mg/m3]	Alarms	Errors
7200	-0.035		
7260	-0.036		
7320	-0.035		
7380	-0.034		
7440	-0.03		
7500	-0.022		
7560	-0.035		
7620	-0.037		
7680	-0.039		
7740	-0.04		
7800	-0.04		
7860	-0.041		
7920	-0.041		
7980	-0.041		
8040	-0.04		
8100	-0.045		
8160	-0.045		
8220	-0.045		
8280	-0.034		
8340	0		
8400	-0.03		
8460	-0.047		
8520	-0.048		
8580	-0.049		
8640	-0.05		
8700	-0.05		
8760	-0.052		
8820	-0.052		
8880	-0.053		
8940	-0.054		
9000	-0.056		
9060	-0.056		
9120	-0.058		
9180	-0.059		
9240	-0.059		
9300	-0.06		
9360	-0.061		
9420	-0.062		
9480	-0.064		
9540	-0.065		
9600	-0.067		
9660	-0.068		
9720	-0.07		
9780	-0.07		
9840	-0.072		
9900	-0.073		

Elapsed Time [s]	Mass [mg/m3]	Alarms	Errors
9960	-0.073		
10020	-0.075		
10080	-0.076		
10140	-0.078		
10200	-0.079		
10260	-0.081		
10320	-0.082		
10380	-0.083		
10440	-0.085		
10500	-0.087		
10560	-0.087		
10620	-0.09		
10680	-0.091		
10740	-0.092		
10800	-0.087		
10860	-0.094		
10920	-0.095		
10980	-0.097		
11040	-0.099		
11100	-0.099		
11160	-0.101		
11220	-0.102		
11280	-0.103		
11340	-0.105		
11400	-0.106		
11460	-0.106		
11520	-0.107		
11580	-0.109		
11640	-0.112		
11700	-0.112		
11760	-0.113		
11820	-0.115		
11880	-0.117		
11940	-0.118		
12000	-0.12		
12060	-0.121		
12120	-0.123		
12180	-0.123		
12240	-0.125		
12300	-0.126		
12360	-0.128		
12420	-0.13		
12480	-0.132		
12540	-0.128		
12600	-0.134		
12660	-0.135		

Elapsed Time [s]	Mass [mg/m3]	Alarms	Errors
12720	-0.135		
12780	-0.135		
12840	-0.135		
12900	-0.135		
12960	-0.135		
13020	-0.135		
13080	-0.135		
13140	-0.135		
13200	-0.135		
13260	-0.135		
13320	-0.135		
13380	-0.136		
13440	-0.136		
13500	-0.135		
13560	-0.135		
13620	-0.135		
13680	-0.135		
13740	-0.136		
13800	-0.136		
13860	-0.135		
13920	-0.135		
13980	-0.136		
14040	-0.136		
14100	-0.136		
14160	-0.136		
14220	-0.136		
14280	-0.136		
14340	-0.135		
14400	-0.136		
14460	-0.136		
14520	-0.136		
14580	-0.136		
14640	-0.136		
14700	-0.136		
14760	-0.136		
14820	-0.136		
14880	-0.136		
14940	-0.136		
15000	-0.136		
15060	-0.136		
15120	-0.136		
15180	-0.136		
15240	-0.136		
15300	-0.136		
15360	-0.136		
15420	-0.136		

Elapsed Time [s]	Mass [mg/m3]	Alarms	Errors
15480	-0.136		
15540	-0.136		
15600	-0.136		
15660	-0.136		
15720	-0.136		
15780	-0.136		
15840	-0.136		
15900	-0.136		
15960	-0.136		
16020	-0.136		
16080	-0.136		
16140	-0.136		
16200	-0.135		
16260	-0.136		
16320	-0.136		
16380	-0.136		
16440	-0.136		
16500	-0.136		
16560	-0.136		
16620	-0.136		
16680	-0.135		
16740	-0.136		
16800	-0.136		
16860	-0.136		
16920	-0.136		
16980	-0.136		
17040	-0.136		
17100	-0.133		
17160	-0.136		
17220	-0.136		
17280	-0.136		
17340	-0.136		
17400	-0.136		
17460	-0.135		
17520	-0.136		
17580	-0.136		
17640	-0.136		
17700	-0.136		
17760	-0.136		
17820	-0.136		
17880	-0.136		
17940	-0.136		
18000	-0.135		
18060	-0.136		
18120	-0.136		
18180	-0.136		

Elapsed Time [s]	Mass [mg/m3]	Alarms	Errors
18240	-0.136		
18300	-0.136		
18360	-0.135		
18420	-0.136		
18480	-0.136		
18540	-0.136		
18600	-0.136		
18660	-0.136		
18720	-0.135		
18780	-0.136		
18840	-0.136		
18900	-0.136		
18960	-0.136		
19020	-0.136		
19080	-0.136		
19140	-0.136		
19200	-0.136		
19260	-0.136		
19320	-0.136		
19380	-0.135		
19440	-0.135		
19500	-0.136		
19560	-0.136		
19620	-0.136		
19680	-0.136		
19740	-0.136		
19800	-0.136		
19860	-0.136		
19920	-0.136		
19980	-0.135		
20040	-0.136		
20100	-0.136		
20160	-0.136		
20220	-0.136		
20280	-0.136		
20340	-0.136		
20400	-0.136		
20460	-0.135		
20520	-0.136		
20580	-0.135		
20640	-0.136		

Instrument Name	DustTrak II
Model Number	8530
Serial Number	8530123517
Firmware Version	3.4
Calibration Date	5/29/2014
Test Name	MANUAL_002
Test Start Time	7:05:55 AM
Test Start Date	6/13/2017
Test Length [D:H:M]	0:07:38
Test Interval [M:S]	1:00
Mass Average [mg/m3]	0.011
Mass Minimum [mg/m3]	-0.07
Mass Maximum [mg/m3]	0.143
Mass TWA [mg/m3]	0.01
Photometric User Cal	0.9
Flow User Cal	0
Errors	
Number of Samples	458

Elapsed Time [s]	Mass [mg/m3]	Alarms	Errors
60	0.143		
120	0.066		
180	0.066		
240	0.066		
300	0.066		
360	0.066		
420	0.066		
480	0.065		
540	0.065		
600	0.065		
660	0.065		
720	0.065		
780	0.065		
840	0.066		
900	0.066		
960	0.066		
1020	0.067		
1080	0.067		
1140	0.068		
1200	0.068		
1260	0.068		
1320	0.068		
1380	0.068		
1440	0.067		
1500	0.067		
1560	0.067		
1620	0.067		

Elapsed Time [s]	Mass [mg/m3]	Alarms	Errors
1680	0.067		
1740	0.066		
1800	0.066		
1860	0.066		
1920	0.066		
1980	0.066		
2040	0.065		
2100	0.066		
2160	0.066		
2220	0.066		
2280	0.066		
2340	0.066		
2400	0.066		
2460	0.066		
2520	0.066		
2580	0.067		
2640	0.067		
2700	0.067		
2760	0.066		
2820	0.067		
2880	0.066		
2940	0.067		
3000	0.067		
3060	0.065		
3120	0.065		
3180	0.065		
3240	0.064		
3300	0.064		
3360	0.065		
3420	0.066		
3480	0.068		
3540	0.065		
3600	0.066		
3660	0.067		
3720	0.065		
3780	0.065		
3840	0.065		
3900	0.065		
3960	0.065		
4020	0.065		
4080	0.065		
4140	0.067		
4200	0.067		
4260	0.066		
4320	0.066		
4380	0.066		

Elapsed Time [s]	Mass [mg/m3]	Alarms	Errors
4440	0.065		
4500	0.065		
4560	0.065		
4620	0.065		
4680	0.065		
4740	0.071		
4800	0.073		
4860	0.068		
4920	0.066		
4980	0.064		
5040	0.064		
5100	0.064		
5160	0.064		
5220	0.065		
5280	0.065		
5340	0.064		
5400	0.065		
5460	0.065		
5520	0.065		
5580	0.064		
5640	0.063		
5700	0.062		
5760	0.064		
5820	0.063		
5880	0.062		
5940	0.062		
6000	0.061		
6060	0.06		
6120	0.059		
6180	0.058		
6240	0.062		
6300	0.062		
6360	0.065		
6420	0.058		
6480	0.057		
6540	0.056		
6600	0.068		
6660	0.055		
6720	0.054		
6780	0.053		
6840	0.053		
6900	0.053		
6960	0.053		
7020	0.052		
7080	0.051		
7140	0.05		

Elapsed Time [s]	Mass [mg/m3]	Alarms	Errors
7200	0.05		
7260	0.05		
7320	0.05		
7380	0.049		
7440	0.049		
7500	0.048		
7560	0.048		
7620	0.048		
7680	0.047		
7740	0.047		
7800	0.045		
7860	0.043		
7920	0.043		
7980	0.043		
8040	0.042		
8100	0.041		
8160	0.039		
8220	0.039		
8280	0.038		
8340	0.045		
8400	0.044		
8460	0.041		
8520	0.037		
8580	0.035		
8640	0.035		
8700	0.034		
8760	0.034		
8820	0.033		
8880	0.031		
8940	0.029		
9000	0.03		
9060	0.027		
9120	0.024		
9180	0.024		
9240	0.022		
9300	0.019		
9360	0.018		
9420	0.016		
9480	0.016		
9540	0.014		
9600	0.013		
9660	0.01		
9720	0.008		
9780	0.01		
9840	0.008		
9900	0.005		

Elapsed Time [s]	Mass [mg/m3]	Alarms	Errors
9960	0.007		
10020	0.005		
10080	0.004		
10140	0.003		
10200	0.003		
10260	0.002		
10320	0.004		
10380	0.004		
10440	0.005		
10500	0.004		
10560	0.004		
10620	0.003		
10680	0.003		
10740	0.002		
10800	0.001		
10860	0		
10920	0		
10980	0		
11040	0		
11100	0		
11160	0		
11220	0		
11280	-0.002		
11340	-0.007		
11400	-0.007		
11460	-0.005		
11520	-0.002		
11580	-0.002		
11640	-0.002		
11700	-0.002		
11760	0		
11820	-0.001		
11880	-0.001		
11940	0		
12000	0		
12060	0		
12120	0		
12180	0		
12240	0		
12300	0		
12360	-0.003		
12420	-0.004		
12480	-0.006		
12540	-0.003		
12600	-0.003		
12660	-0.003		

Elapsed Time [s]	Mass [mg/m3]	Alarms	Errors
12720	-0.002		
12780	0		
12840	0		
12900	0		
12960	0		
13020	0.001		
13080	0		
13140	0.001		
13200	0.002		
13260	0.002		
13320	0.003		
13380	0.003		
13440	0.004		
13500	0.004		
13560	0.003		
13620	0.006		
13680	0.006		
13740	0.007		
13800	0.006		
13860	0.006		
13920	0.007		
13980	0.007		
14040	0.006		
14100	0.006		
14160	0.005		
14220	0.004		
14280	0.005		
14340	0.008		
14400	0.004		
14460	0.011		
14520	0.011		
14580	0.012		
14640	0.01		
14700	0.008		
14760	0.007		
14820	0.011		
14880	0.014		
14940	0.014		
15000	0.017		
15060	0.015		
15120	0.011		
15180	0.011		
15240	0.012		
15300	0.011		
15360	0.01		
15420	0.009		

Elapsed Time [s]	Mass [mg/m3]	Alarms	Errors
15480	0.008		
15540	0.009		
15600	0.009		
15660	0.011		
15720	0.015		
15780	0.014		
15840	0.015		
15900	0.012		
15960	0.007		
16020	0.008		
16080	0.007		
16140	0.008		
16200	0.007		
16260	0.005		
16320	0.003		
16380	0.007		
16440	0.004		
16500	0.002		
16560	0.001		
16620	-0.003		
16680	-0.001		
16740	0.006		
16800	0.001		
16860	0.008		
16920	0.006		
16980	0		
17040	0.001		
17100	0.001		
17160	0		
17220	0		
17280	-0.005		
17340	0.001		
17400	0.002		
17460	0.001		
17520	0.001		
17580	0		
17640	0		
17700	0		
17760	0		
17820	0		
17880	0		
17940	0		
18000	-0.001		
18060	-0.002		
18120	-0.002		
18180	-0.003		

Elapsed Time [s]	Mass [mg/m3]	Alarms	Errors
18240	-0.004		
18300	-0.005		
18360	-0.005		
18420	-0.006		
18480	-0.007		
18540	-0.008		
18600	-0.009		
18660	-0.01		
18720	-0.01		
18780	-0.012		
18840	-0.013		
18900	-0.013		
18960	-0.014		
19020	-0.014		
19080	-0.016		
19140	-0.014		
19200	-0.015		
19260	-0.015		
19320	-0.016		
19380	-0.017		
19440	-0.018		
19500	-0.018		
19560	-0.019		
19620	-0.019		
19680	-0.02		
19740	-0.022		
19800	-0.036		
19860	-0.029		
19920	-0.028		
19980	-0.034		
20040	-0.023		
20100	-0.029		
20160	-0.038		
20220	-0.042		
20280	-0.035		
20340	-0.034		
20400	-0.031		
20460	-0.032		
20520	-0.044		
20580	-0.048		
20640	-0.045		
20700	-0.048		
20760	-0.053		
20820	-0.032		
20880	-0.033		
20940	-0.033		

Elapsed Time [s]	Mass [mg/m3]	Alarms	Errors
21000	-0.033		
21060	-0.033		
21120	-0.033		
21180	-0.034		
21240	-0.034		
21300	-0.034		
21360	-0.035		
21420	-0.035		
21480	-0.035		
21540	-0.036		
21600	-0.036		
21660	-0.036		
21720	-0.036		
21780	-0.036		
21840	-0.037		
21900	-0.037		
21960	-0.037		
22020	-0.037		
22080	-0.038		
22140	-0.038		
22200	-0.039		
22260	-0.039		
22320	-0.039		
22380	-0.039		
22440	-0.04		
22500	-0.042		
22560	-0.042		
22620	-0.054		
22680	-0.061		
22740	-0.07		
22800	-0.059		
22860	-0.047		
22920	-0.046		
22980	-0.045		
23040	-0.043		
23100	-0.046		
23160	-0.045		
23220	-0.046		
23280	-0.046		
23340	-0.05		
23400	-0.048		
23460	-0.05		
23520	-0.045		
23580	-0.04		
23640	-0.044		
23700	-0.043		

Elapsed Time [s]	Mass [mg/m3]	Alarms	Errors
23760	-0.044		
23820	-0.046		
23880	-0.05		
23940	-0.044		
24000	-0.042		
24060	-0.042		
24120	-0.042		
24180	-0.041		
24240	-0.043		
24300	-0.043		
24360	-0.043		
24420	-0.043		
24480	-0.041		
24540	-0.038		
24600	-0.038		
24660	-0.036		
24720	-0.034		
24780	-0.033		
24840	-0.033		
24900	-0.032		
24960	-0.032		
25020	-0.032		
25080	-0.031		
25140	-0.03		
25200	-0.031		
25260	-0.03		
25320	-0.03		
25380	-0.03		
25440	-0.029		
25500	-0.029		
25560	-0.029		
25620	-0.028		
25680	-0.028		
25740	-0.028		
25800	-0.027		
25860	-0.026		
25920	-0.025		
25980	-0.025		
26040	-0.025		
26100	-0.025		
26160	-0.024		
26220	-0.024		
26280	-0.024		
26340	-0.023		
26400	-0.022		
26460	-0.022		

Elapsed Time [s]	Mass [mg/m3]	Alarms	Errors
26520	-0.021		
26580	-0.02		
26640	-0.021		
26700	-0.021		
26760	-0.019		
26820	-0.017		
26880	-0.018		
26940	-0.018		
27000	-0.017		
27060	-0.017		
27120	-0.015		
27180	-0.014		
27240	-0.012		
27300	-0.013		
27360	-0.009		
27420	-0.008		
27480	-0.006		

Instrument Name	DustTrak II
Model Number	8530
Serial Number	8530123517
Firmware Version	3.4
Calibration Date	5/29/2014
Test Name	MANUAL_003
Test Start Time	10:06:39 AM
Test Start Date	6/14/2017
Test Length [D:H:M]	0:05:12
Test Interval [M:S]	1:00
Mass Average [mg/m3]	-0.038
Mass Minimum [mg/m3]	-0.084
Mass Maximum [mg/m3]	0.01
Mass TWA [mg/m3]	-0.024
Photometric User Cal	0.9
Flow User Cal	0
Errors	
Number of Samples	312

Elapsed Time [s]	Mass [mg/m3]	Alarms	Errors
60	0.008		
120	0.008		
180	0.007		
240	0.007		
300	0.007		
360	0.007		
420	0.008		
480	0.007		
540	0.008		
600	0.008		
660	0.008		
720	0.008		
780	0.01		
840	0.008		
900	0.008		
960	0.008		
1020	0.009		
1080	0.009		
1140	0.009		
1200	0.009		
1260	0.008		
1320	0.008		
1380	0.008		
1440	0.009		
1500	0.009		
1560	0.009		
1620	0.009		

Elapsed Time [s]	Mass [mg/m3]	Alarms	Errors
1680	0.008		
1740	0.009		
1800	0.009		
1860	0.009		
1920	0.008		
1980	0.009		
2040	0.01		
2100	0.01		
2160	0.009		
2220	0.009		
2280	0.009		
2340	0.01		
2400	0.01		
2460	0.01		
2520	0.01		
2580	0.009		
2640	0.009		
2700	0.009		
2760	0.008		
2820	0.008		
2880	0.008		
2940	0.008		
3000	0.007		
3060	0.006		
3120	0.005		
3180	0.004		
3240	0.004		
3300	0.003		
3360	0.002		
3420	0.001		
3480	0		
3540	0		
3600	0		
3660	0		
3720	-0.001		
3780	-0.002		
3840	-0.004		
3900	-0.006		
3960	-0.007		
4020	-0.009		
4080	-0.014		
4140	-0.018		
4200	-0.021		
4260	-0.023		
4320	-0.018		
4380	-0.019		

Elapsed Time [s]	Mass [mg/m3]	Alarms	Errors
4440	-0.019		
4500	-0.021		
4560	-0.02		
4620	-0.021		
4680	-0.022		
4740	-0.024		
4800	-0.024		
4860	-0.025		
4920	-0.024		
4980	-0.025		
5040	-0.026		
5100	-0.028		
5160	-0.028		
5220	-0.028		
5280	-0.03		
5340	-0.031		
5400	-0.032		
5460	-0.033		
5520	-0.034		
5580	-0.034		
5640	-0.035		
5700	-0.037		
5760	-0.037		
5820	-0.044		
5880	-0.044		
5940	-0.048		
6000	-0.055		
6060	-0.047		
6120	-0.056		
6180	-0.056		
6240	-0.049		
6300	-0.049		
6360	-0.047		
6420	-0.048		
6480	-0.048		
6540	-0.044		
6600	-0.048		
6660	-0.048		
6720	-0.049		
6780	-0.049		
6840	-0.049		
6900	-0.049		
6960	-0.049		
7020	-0.05		
7080	-0.05		
7140	-0.051		

Elapsed Time [s]	Mass [mg/m3]	Alarms	Errors
7200	-0.051		
7260	-0.051		
7320	-0.052		
7380	-0.053		
7440	-0.053		
7500	-0.054		
7560	-0.055		
7620	-0.055		
7680	-0.069		
7740	-0.068		
7800	-0.075		
7860	-0.078		
7920	-0.078		
7980	-0.081		
8040	-0.08		
8100	-0.084		
8160	-0.077		
8220	-0.075		
8280	-0.072		
8340	-0.073		
8400	-0.074		
8460	-0.071		
8520	-0.064		
8580	-0.064		
8640	-0.064		
8700	-0.066		
8760	-0.064		
8820	-0.062		
8880	-0.059		
8940	-0.059		
9000	-0.051		
9060	-0.06		
9120	-0.06		
9180	-0.06		
9240	-0.06		
9300	-0.06		
9360	-0.061		
9420	-0.06		
9480	-0.059		
9540	-0.06		
9600	-0.061		
9660	-0.06		
9720	-0.061		
9780	-0.062		
9840	-0.062		
9900	-0.063		

Elapsed Time [s]	Mass [mg/m3]	Alarms	Errors
9960	-0.062		
10020	-0.062		
10080	-0.063		
10140	-0.064		
10200	-0.061		
10260	-0.061		
10320	-0.062		
10380	-0.062		
10440	-0.062		
10500	-0.062		
10560	-0.062		
10620	-0.062		
10680	-0.062		
10740	-0.062		
10800	-0.062		
10860	-0.061		
10920	-0.062		
10980	-0.062		
11040	-0.062		
11100	-0.062		
11160	-0.062		
11220	-0.062		
11280	-0.062		
11340	-0.062		
11400	-0.063		
11460	-0.063		
11520	-0.063		
11580	-0.063		
11640	-0.063		
11700	-0.063		
11760	-0.063		
11820	-0.064		
11880	-0.063		
11940	-0.064		
12000	-0.063		
12060	-0.063		
12120	-0.064		
12180	-0.064		
12240	-0.064		
12300	-0.065		
12360	-0.065		
12420	-0.065		
12480	-0.065		
12540	-0.067		
12600	-0.066		
12660	-0.065		

Elapsed Time [s]	Mass [mg/m3]	Alarms	Errors
12720	-0.065		
12780	-0.065		
12840	-0.065		
12900	-0.064		
12960	-0.061		
13020	-0.061		
13080	-0.06		
13140	-0.061		
13200	-0.06		
13260	-0.058		
13320	-0.058		
13380	-0.058		
13440	-0.058		
13500	-0.057		
13560	-0.056		
13620	-0.054		
13680	-0.054		
13740	-0.053		
13800	-0.053		
13860	-0.053		
13920	-0.052		
13980	-0.052		
14040	-0.052		
14100	-0.052		
14160	-0.051		
14220	-0.051		
14280	-0.051		
14340	-0.05		
14400	-0.05		
14460	-0.049		
14520	-0.049		
14580	-0.048		
14640	-0.048		
14700	-0.047		
14760	-0.047		
14820	-0.046		
14880	-0.046		
14940	-0.046		
15000	-0.045		
15060	-0.045		
15120	-0.045		
15180	-0.044		
15240	-0.044		
15300	-0.044		
15360	-0.043		
15420	-0.043		

Elapsed Time [s]	Mass [mg/m3]	Alarms	Errors
15480	-0.043		
15540	-0.042		
15600	-0.042		
15660	-0.042		
15720	-0.042		
15780	-0.041		
15840	-0.041		
15900	-0.041		
15960	-0.04		
16020	-0.038		
16080	-0.038		
16140	-0.039		
16200	-0.039		
16260	-0.039		
16320	-0.038		
16380	-0.038		
16440	-0.037		
16500	-0.037		
16560	-0.036		
16620	-0.037		
16680	-0.037		
16740	-0.036		
16800	-0.036		
16860	-0.036		
16920	-0.035		
16980	-0.035		
17040	-0.035		
17100	-0.035		
17160	-0.035		
17220	-0.035		
17280	-0.036		
17340	-0.035		
17400	-0.035		
17460	-0.035		
17520	-0.035		
17580	-0.034		
17640	-0.034		
17700	-0.035		
17760	-0.035		
17820	-0.035		
17880	-0.035		
17940	-0.035		
18000	-0.01		
18060	-0.035		
18120	-0.035		
18180	-0.035		

Elapsed Time [s]	Mass [mg/m3]	Alarms	Errors
18240	-0.035		
18300	-0.035		
18360	-0.036		
18420	-0.036		
18480	-0.036		
18540	-0.036		
18600	-0.036		
18660	-0.036		
18720	-0.036		

Instrument Name	DustTrak II
Model Number	8530
Serial Number	8530113113
Firmware Version	3.4
Calibration Date	7/12/2016
Test Name	MANUAL_004
Test Start Time	8:07:35 AM
Test Start Date	6/15/2017
Test Length [D:H:M]	0:07:10
Test Interval [M:S]	1:00
Mass Average [mg/m3]	0.013
Mass Minimum [mg/m3]	0.01
Mass Maximum [mg/m3]	0.043
Mass TWA [mg/m3]	0.012
Photometric User Cal	1
Flow User Cal	0
Errors	
Number of Samples	430

Elapsed Time [s]	Mass [mg/m3]	Alarms	Errors
60	0.012		
120	0.011		
180	0.011		
240	0.011		
300	0.011		
360	0.011		
420	0.011		
480	0.011		
540	0.01		
600	0.01		
660	0.011		
720	0.01		
780	0.01		
840	0.01		
900	0.01		
960	0.011		
1020	0.01		
1080	0.01		
1140	0.01		
1200	0.01		
1260	0.01		
1320	0.011		
1380	0.01		
1440	0.011		
1500	0.011		
1560	0.01		
1620	0.01		

Elapsed Time [s]	Mass [mg/m3]	Alarms	Errors
1680	0.01		
1740	0.01		
1800	0.01		
1860	0.01		
1920	0.01		
1980	0.01		
2040	0.011		
2100	0.011		
2160	0.01		
2220	0.01		
2280	0.01		
2340	0.011		
2400	0.011		
2460	0.01		
2520	0.011		
2580	0.011		
2640	0.01		
2700	0.01		
2760	0.01		
2820	0.011		
2880	0.011		
2940	0.011		
3000	0.011		
3060	0.011		
3120	0.01		
3180	0.011		
3240	0.011		
3300	0.011		
3360	0.011		
3420	0.011		
3480	0.011		
3540	0.011		
3600	0.011		
3660	0.011		
3720	0.011		
3780	0.011		
3840	0.011		
3900	0.011		
3960	0.011		
4020	0.011		
4080	0.011		
4140	0.011		
4200	0.012		
4260	0.012		
4320	0.011		
4380	0.011		

Elapsed Time [s]	Mass [mg/m3]	Alarms	Errors
4440	0.011		
4500	0.011		
4560	0.011		
4620	0.012		
4680	0.011		
4740	0.011		
4800	0.011		
4860	0.011		
4920	0.011		
4980	0.011		
5040	0.011		
5100	0.011		
5160	0.011		
5220	0.011		
5280	0.011		
5340	0.011		
5400	0.011		
5460	0.012		
5520	0.011		
5580	0.012		
5640	0.011		
5700	0.011		
5760	0.011		
5820	0.011		
5880	0.011		
5940	0.011		
6000	0.011		
6060	0.011		
6120	0.011		
6180	0.011		
6240	0.011		
6300	0.011		
6360	0.01		
6420	0.011		
6480	0.011		
6540	0.011		
6600	0.011		
6660	0.011		
6720	0.011		
6780	0.011		
6840	0.011		
6900	0.01		
6960	0.011		
7020	0.011		
7080	0.01		
7140	0.011		

Elapsed Time [s]	Mass [mg/m3]	Alarms	Errors
7200	0.011		
7260	0.011		
7320	0.011		
7380	0.011		
7440	0.011		
7500	0.011		
7560	0.011		
7620	0.011		
7680	0.011		
7740	0.011		
7800	0.011		
7860	0.011		
7920	0.011		
7980	0.011		
8040	0.011		
8100	0.011		
8160	0.011		
8220	0.011		
8280	0.011		
8340	0.011		
8400	0.012		
8460	0.012		
8520	0.012		
8580	0.012		
8640	0.012		
8700	0.012		
8760	0.012		
8820	0.012		
8880	0.013		
8940	0.016		
9000	0.043		
9060	0.026		
9120	0.035		
9180	0.013		
9240	0.014		
9300	0.013		
9360	0.014		
9420	0.013		
9480	0.012		
9540	0.012		
9600	0.012		
9660	0.012		
9720	0.012		
9780	0.013		
9840	0.013		
9900	0.012		

Elapsed Time [s]	Mass [mg/m3]	Alarms	Errors
9960	0.012		
10020	0.013		
10080	0.013		
10140	0.012		
10200	0.013		
10260	0.013		
10320	0.013		
10380	0.012		
10440	0.012		
10500	0.013		
10560	0.013		
10620	0.013		
10680	0.014		
10740	0.013		
10800	0.011		
10860	0.013		
10920	0.013		
10980	0.013		
11040	0.013		
11100	0.013		
11160	0.013		
11220	0.014		
11280	0.013		
11340	0.014		
11400	0.014		
11460	0.014		
11520	0.013		
11580	0.014		
11640	0.014		
11700	0.014		
11760	0.015		
11820	0.016		
11880	0.016		
11940	0.016		
12000	0.016		
12060	0.017		
12120	0.016		
12180	0.017		
12240	0.016		
12300	0.016		
12360	0.016		
12420	0.015		
12480	0.016		
12540	0.015		
12600	0.016		
12660	0.015		

Elapsed Time [s]	Mass [mg/m3]	Alarms	Errors
12720	0.015		
12780	0.015		
12840	0.017		
12900	0.015		
12960	0.016		
13020	0.017		
13080	0.016		
13140	0.015		
13200	0.016		
13260	0.015		
13320	0.017		
13380	0.016		
13440	0.015		
13500	0.015		
13560	0.014		
13620	0.014		
13680	0.013		
13740	0.012		
13800	0.014		
13860	0.014		
13920	0.013		
13980	0.013		
14040	0.013		
14100	0.013		
14160	0.013		
14220	0.013		
14280	0.014		
14340	0.014		
14400	0.012		
14460	0.014		
14520	0.013		
14580	0.013		
14640	0.012		
14700	0.013		
14760	0.013		
14820	0.012		
14880	0.012		
14940	0.012		
15000	0.012		
15060	0.012		
15120	0.012		
15180	0.012		
15240	0.012		
15300	0.012		
15360	0.013		
15420	0.013		

Elapsed Time [s]	Mass [mg/m3]	Alarms	Errors
15480	0.013		
15540	0.012		
15600	0.012		
15660	0.012		
15720	0.012		
15780	0.012		
15840	0.012		
15900	0.012		
15960	0.012		
16020	0.012		
16080	0.012		
16140	0.012		
16200	0.013		
16260	0.013		
16320	0.013		
16380	0.013		
16440	0.013		
16500	0.012		
16560	0.012		
16620	0.012		
16680	0.012		
16740	0.012		
16800	0.012		
16860	0.012		
16920	0.013		
16980	0.013		
17040	0.013		
17100	0.013		
17160	0.012		
17220	0.013		
17280	0.013		
17340	0.014		
17400	0.015		
17460	0.018		
17520	0.015		
17580	0.014		
17640	0.016		
17700	0.015		
17760	0.015		
17820	0.016		
17880	0.014		
17940	0.015		
18000	0.014		
18060	0.014		
18120	0.017		
18180	0.014		

Elapsed Time [s]	Mass [mg/m3]	Alarms	Errors
18240	0.015		
18300	0.014		
18360	0.015		
18420	0.015		
18480	0.015		
18540	0.014		
18600	0.014		
18660	0.014		
18720	0.015		
18780	0.014		
18840	0.013		
18900	0.014		
18960	0.013		
19020	0.013		
19080	0.013		
19140	0.013		
19200	0.013		
19260	0.013		
19320	0.012		
19380	0.013		
19440	0.013		
19500	0.013		
19560	0.013		
19620	0.013		
19680	0.013		
19740	0.013		
19800	0.012		
19860	0.012		
19920	0.013		
19980	0.013		
20040	0.012		
20100	0.013		
20160	0.013		
20220	0.013		
20280	0.013		
20340	0.014		
20400	0.013		
20460	0.014		
20520	0.014		
20580	0.013		
20640	0.014		
20700	0.013		
20760	0.013		
20820	0.013		
20880	0.013		
20940	0.013		

Elapsed Time [s]	Mass [mg/m3]	Alarms	Errors
21000	0.013		
21060	0.013		
21120	0.013		
21180	0.013		
21240	0.013		
21300	0.013		
21360	0.015		
21420	0.013		
21480	0.014		
21540	0.014		
21600	0.014		
21660	0.014		
21720	0.016		
21780	0.015		
21840	0.016		
21900	0.017		
21960	0.016		
22020	0.015		
22080	0.016		
22140	0.016		
22200	0.016		
22260	0.016		
22320	0.015		
22380	0.016		
22440	0.015		
22500	0.016		
22560	0.016		
22620	0.016		
22680	0.016		
22740	0.015		
22800	0.016		
22860	0.016		
22920	0.016		
22980	0.016		
23040	0.016		
23100	0.017		
23160	0.016		
23220	0.016		
23280	0.016		
23340	0.016		
23400	0.016		
23460	0.016		
23520	0.016		
23580	0.016		
23640	0.017		
23700	0.016		

Elapsed Time [s]	Mass [mg/m3]	Alarms	Errors
23760	0.016		
23820	0.016		
23880	0.016		
23940	0.015		
24000	0.015		
24060	0.015		
24120	0.015		
24180	0.015		
24240	0.015		
24300	0.015		
24360	0.015		
24420	0.014		
24480	0.014		
24540	0.014		
24600	0.014		
24660	0.015		
24720	0.014		
24780	0.014		
24840	0.014		
24900	0.015		
24960	0.014		
25020	0.014		
25080	0.014		
25140	0.014		
25200	0.014		
25260	0.015		
25320	0.014		
25380	0.014		
25440	0.014		
25500	0.014		
25560	0.014		
25620	0.014		
25680	0.014		
25740	0.014		
25800	0.014		

Instrument Name	DustTrak II
Model Number	8530
Serial Number	8530113113
Firmware Version	3.4
Calibration Date	7/12/2016
Test Name	MANUAL_005
Test Start Time	10:16:17 AM
Test Start Date	6/19/2017
Test Length [D:H:M]	0:02:12
Test Interval [M:S]	1:00
Mass Average [mg/m3]	0.031
Mass Minimum [mg/m3]	-0.029
Mass Maximum [mg/m3]	0.169
Mass TWA [mg/m3]	0.009
Photometric User Cal	1
Flow User Cal	0
Errors	
Number of Samples	132

Elapsed Time [s]	Mass [mg/m3]	Alarms	Errors
60	0.042		
120	0.039		
180	0.043		
240	0.039		
300	0.038		
360	0.038		
420	0.039		
480	0.039		
540	0.038		
600	0.043		
660	0.039		
720	0.04		
780	0.042		
840	0.169		
900	0.092		
960	0.04		
1020	0.037		
1080	0.037		
1140	0.041		
1200	0.05		
1260	0.045		
1320	0.038		
1380	0.038		
1440	0.037		
1500	0.037		
1560	0.043		
1620	0.041		

Elapsed Time [s]	Mass [mg/m3]	Alarms	Errors
1680	0.04		
1740	0.037		
1800	0.036		
1860	0.036		
1920	0.038		
1980	0.037		
2040	0.039		
2100	0.038		
2160	0.05		
2220	0.049		
2280	0.044		
2340	0.035		
2400	0.037		
2460	0.037		
2520	0.037		
2580	0.037		
2640	0.037		
2700	0.037		
2760	0.048		
2820	0.1		
2880	0.057		
2940	0.046		
3000	0.048		
3060	0.039		
3120	0.044		
3180	0.077		
3240	0.038		
3300	0.044		
3360	0.038		
3420	0.037		
3480	0.062		
3540	0.044		
3600	0.039		
3660	0.038		
3720	0.039		
3780	0.052		
3840	0.065		
3900	0.077		
3960	0.043		
4020	0.039		
4080	0.056		
4140	0.039		
4200	0.039		
4260	0.037		
4320	0.04		
4380	0.05		

Elapsed Time [s]	Mass [mg/m3]	Alarms	Errors
4440	0.065		
4500	0.036		
4560	0.034		
4620	0.038		
4680	0.038		
4740	0.036		
4800	0.037		
4860	0.037		
4920	0.035		
4980	0.034		
5040	0.035		
5100	0.034		
5160	0.033		
5220	0.038		
5280	0.033		
5340	0.035		
5400	0.035		
5460	0.035		
5520	0.036		
5580	0.039		
5640	0.042		
5700	0.037		
5760	0.056		
5820	0.039		
5880	0.035		
5940	0.035		
6000	0.042		
6060	0.04		
6120	0.041		
6180	0.034		
6240	0.036		
6300	0.04		
6360	0.001		
6420	-0.012		
6480	-0.014		
6540	-0.018		
6600	-0.018		
6660	-0.021		
6720	-0.02		
6780	-0.02		
6840	-0.021		
6900	-0.027		
6960	-0.024		
7020	-0.025		
7080	-0.025		
7140	-0.025		

Elapsed Time [s]	Mass [mg/m3]	Alarms	Errors
7200	-0.021		
7260	0.036		
7320	0.048		
7380	-0.022		
7440	-0.023		
7500	-0.015		
7560	-0.01		
7620	-0.028		
7680	-0.027		
7740	-0.028		
7800	-0.029		
7860	-0.027		
7920	-0.017		

Instrument Name	DustTrak II
Model Number	8530
Serial Number	8530123517
Firmware Version	3.4
Calibration Date	5/29/2014
Test Name	MANUAL_004
Test Start Time	7:55:16 AM
Test Start Date	6/15/2017
Test Length [D:H:M]	0:07:23
Test Interval [M:S]	1:00
Mass Average [mg/m3]	0.011
Mass Minimum [mg/m3]	0.005
Mass Maximum [mg/m3]	0.087
Mass TWA [mg/m3]	0.01
Photometric User Cal	0.9
Flow User Cal	0
Errors	
Number of Samples	443

Elapsed Time [s]	Mass [mg/m3]	Alarms	Errors
60	0.012		
120	0.01		
180	0.009		
240	0.01		
300	0.01		
360	0.008		
420	0.008		
480	0.007		
540	0.008		
600	0.008		
660	0.008		
720	0.008		
780	0.009		
840	0.009		
900	0.009		
960	0.009		
1020	0.009		
1080	0.009		
1140	0.009		
1200	0.009		
1260	0.009		
1320	0.009		
1380	0.009		
1440	0.009		
1500	0.009		
1560	0.009		
1620	0.009		

Elapsed Time [s]	Mass [mg/m3]	Alarms	Errors
1680	0.009		
1740	0.009		
1800	0.009		
1860	0.008		
1920	0.008		
1980	0.009		
2040	0.008		
2100	0.008		
2160	0.009		
2220	0.009		
2280	0.008		
2340	0.009		
2400	0.009		
2460	0.009		
2520	0.009		
2580	0.009		
2640	0.009		
2700	0.009		
2760	0.01		
2820	0.009		
2880	0.009		
2940	0.008		
3000	0.009		
3060	0.009		
3120	0.009		
3180	0.009		
3240	0.009		
3300	0.009		
3360	0.008		
3420	0.008		
3480	0.018		
3540	0.012		
3600	0.009		
3660	0.008		
3720	0.008		
3780	0.008		
3840	0.008		
3900	0.008		
3960	0.008		
4020	0.008		
4080	0.009		
4140	0.008		
4200	0.009		
4260	0.009		
4320	0.009		
4380	0.009		

Elapsed Time [s]	Mass [mg/m3]	Alarms	Errors
4440	0.009		
4500	0.009		
4560	0.008		
4620	0.008		
4680	0.009		
4740	0.009		
4800	0.009		
4860	0.009		
4920	0.009		
4980	0.008		
5040	0.008		
5100	0.009		
5160	0.009		
5220	0.009		
5280	0.009		
5340	0.009		
5400	0.009		
5460	0.009		
5520	0.009		
5580	0.009		
5640	0.009		
5700	0.009		
5760	0.009		
5820	0.009		
5880	0.009		
5940	0.01		
6000	0.009		
6060	0.009		
6120	0.009		
6180	0.009		
6240	0.009		
6300	0.009		
6360	0.009		
6420	0.009		
6480	0.009		
6540	0.009		
6600	0.009		
6660	0.009		
6720	0.009		
6780	0.009		
6840	0.009		
6900	0.009		
6960	0.009		
7020	0.009		
7080	0.009		
7140	0.009		

Elapsed Time [s]	Mass [mg/m3]	Alarms	Errors
7200	0.008		
7260	0.008		
7320	0.008		
7380	0.008		
7440	0.009		
7500	0.009		
7560	0.008		
7620	0.008		
7680	0.009		
7740	0.009		
7800	0.008		
7860	0.008		
7920	0.008		
7980	0.009		
8040	0.008		
8100	0.008		
8160	0.008		
8220	0.008		
8280	0.008		
8340	0.009		
8400	0.008		
8460	0.008		
8520	0.009		
8580	0.008		
8640	0.008		
8700	0.008		
8760	0.009		
8820	0.008		
8880	0.008		
8940	0.008		
9000	0.008		
9060	0.008		
9120	0.008		
9180	0.008		
9240	0.008		
9300	0.008		
9360	0.008		
9420	0.008		
9480	0.008		
9540	0.008		
9600	0.007		
9660	0.007		
9720	0.087		
9780	0.029		
9840	0.014		
9900	0.007		

Elapsed Time [s]	Mass [mg/m3]	Alarms	Errors
9960	0.006		
10020	0.007		
10080	0.006		
10140	0.005		
10200	0.005		
10260	0.006		
10320	0.005		
10380	0.005		
10440	0.005		
10500	0.005		
10560	0.006		
10620	0.005		
10680	0.005		
10740	0.005		
10800	0.005		
10860	0.007		
10920	0.006		
10980	0.005		
11040	0.007		
11100	0.006		
11160	0.006		
11220	0.006		
11280	0.006		
11340	0.006		
11400	0.006		
11460	0.006		
11520	0.007		
11580	0.007		
11640	0.006		
11700	0.007		
11760	0.007		
11820	0.007		
11880	0.007		
11940	0.007		
12000	0.008		
12060	0.008		
12120	0.008		
12180	0.009		
12240	0.008		
12300	0.009		
12360	0.009		
12420	0.01		
12480	0.011		
12540	0.012		
12600	0.012		
12660	0.011		

Elapsed Time [s]	Mass [mg/m3]	Alarms	Errors
12720	0.012		
12780	0.012		
12840	0.012		
12900	0.012		
12960	0.012		
13020	0.012		
13080	0.012		
13140	0.011		
13200	0.011		
13260	0.012		
13320	0.012		
13380	0.011		
13440	0.011		
13500	0.011		
13560	0.011		
13620	0.013		
13680	0.012		
13740	0.012		
13800	0.012		
13860	0.011		
13920	0.012		
13980	0.012		
14040	0.012		
14100	0.012		
14160	0.012		
14220	0.011		
14280	0.01		
14340	0.01		
14400	0.009		
14460	0.009		
14520	0.009		
14580	0.009		
14640	0.009		
14700	0.009		
14760	0.009		
14820	0.009		
14880	0.009		
14940	0.009		
15000	0.009		
15060	0.01		
15120	0.01		
15180	0.01		
15240	0.009		
15300	0.01		
15360	0.009		
15420	0.009		

Elapsed Time [s]	Mass [mg/m3]	Alarms	Errors
15480	0.01		
15540	0.009		
15600	0.009		
15660	0.009		
15720	0.009		
15780	0.009		
15840	0.009		
15900	0.009		
15960	0.01		
16020	0.01		
16080	0.01		
16140	0.01		
16200	0.01		
16260	0.01		
16320	0.009		
16380	0.009		
16440	0.009		
16500	0.009		
16560	0.01		
16620	0.01		
16680	0.01		
16740	0.01		
16800	0.01		
16860	0.011		
16920	0.011		
16980	0.011		
17040	0.011		
17100	0.011		
17160	0.01		
17220	0.011		
17280	0.01		
17340	0.01		
17400	0.01		
17460	0.01		
17520	0.01		
17580	0.01		
17640	0.011		
17700	0.011		
17760	0.01		
17820	0.01		
17880	0.01		
17940	0.011		
18000	0.013		
18060	0.012		
18120	0.012		
18180	0.012		

Elapsed Time [s]	Mass [mg/m3]	Alarms	Errors
18240	0.012		
18300	0.013		
18360	0.013		
18420	0.012		
18480	0.011		
18540	0.012		
18600	0.012		
18660	0.013		
18720	0.013		
18780	0.013		
18840	0.012		
18900	0.013		
18960	0.012		
19020	0.013		
19080	0.012		
19140	0.012		
19200	0.064		
19260	0.013		
19320	0.016		
19380	0.015		
19440	0.013		
19500	0.012		
19560	0.015		
19620	0.012		
19680	0.014		
19740	0.014		
19800	0.017		
19860	0.021		
19920	0.017		
19980	0.016		
20040	0.012		
20100	0.01		
20160	0.011		
20220	0.011		
20280	0.013		
20340	0.016		
20400	0.01		
20460	0.032		
20520	0.01		
20580	0.011		
20640	0.011		
20700	0.011		
20760	0.011		
20820	0.011		
20880	0.013		
20940	0.012		

Elapsed Time [s]	Mass [mg/m3]	Alarms	Errors
21000	0.017		
21060	0.013		
21120	0.011		
21180	0.011		
21240	0.011		
21300	0.013		
21360	0.013		
21420	0.011		
21480	0.011		
21540	0.011		
21600	0.014		
21660	0.011		
21720	0.012		
21780	0.013		
21840	0.011		
21900	0.012		
21960	0.011		
22020	0.013		
22080	0.017		
22140	0.012		
22200	0.012		
22260	0.012		
22320	0.015		
22380	0.015		
22440	0.015		
22500	0.016		
22560	0.015		
22620	0.014		
22680	0.013		
22740	0.012		
22800	0.015		
22860	0.02		
22920	0.015		
22980	0.012		
23040	0.013		
23100	0.013		
23160	0.012		
23220	0.014		
23280	0.015		
23340	0.014		
23400	0.02		
23460	0.025		
23520	0.017		
23580	0.013		
23640	0.015		
23700	0.014		

Elapsed Time [s]	Mass [mg/m3]	Alarms	Errors
23760	0.016		
23820	0.014		
23880	0.012		
23940	0.014		
24000	0.013		
24060	0.013		
24120	0.014		
24180	0.014		
24240	0.013		
24300	0.014		
24360	0.016		
24420	0.017		
24480	0.015		
24540	0.015		
24600	0.015		
24660	0.013		
24720	0.012		
24780	0.012		
24840	0.014		
24900	0.016		
24960	0.012		
25020	0.013		
25080	0.012		
25140	0.012		
25200	0.011		
25260	0.012		
25320	0.012		
25380	0.011		
25440	0.012		
25500	0.016		
25560	0.012		
25620	0.013		
25680	0.012		
25740	0.015		
25800	0.013		
25860	0.012		
25920	0.018		
25980	0.015		
26040	0.012		
26100	0.011		
26160	0.015		
26220	0.014		
26280	0.011		
26340	0.013		
26400	0.014		
26460	0.011		

Elapsed Time [s]	Mass [mg/m3]	Alarms	Errors
26520	0.011		
26580	0.012		

Instrument Name	DustTrak II
Model Number	8530
Serial Number	8530123517
Firmware Version	3.4
Calibration Date	5/29/2014
Test Name	MANUAL_005
Test Start Time	10:14:58 AM
Test Start Date	6/19/2017
Test Length [D:H:M]	0:02:12
Test Interval [M:S]	1:00
Mass Average [mg/m3]	0.019
Mass Minimum [mg/m3]	-0.002
Mass Maximum [mg/m3]	0.033
Mass TWA [mg/m3]	0.005
Photometric User Cal	0.9
Flow User Cal	0
Errors	
Number of Samples	132

Elapsed Time [s]	Mass [mg/m3]	Alarms	Errors
60	0.033		
120	0.032		
180	0.032		
240	0.032		
300	0.032		
360	0.032		
420	0.033		
480	0.033		
540	0.032		
600	0.032		
660	0.031		
720	0.032		
780	0.032		
840	0.032		
900	0.031		
960	0.031		
1020	0.031		
1080	0.03		
1140	0.03		
1200	0.031		
1260	0.031		
1320	0.031		
1380	0.031		
1440	0.03		
1500	0.03		
1560	0.03		
1620	0.031		

Elapsed Time [s]	Mass [mg/m3]	Alarms	Errors
1680	0.031		
1740	0.031		
1800	0.03		
1860	0.029		
1920	0.03		
1980	0.029		
2040	0.029		
2100	0.029		
2160	0.029		
2220	0.029		
2280	0.029		
2340	0.03		
2400	0.029		
2460	0.029		
2520	0.029		
2580	0.029		
2640	0.022		
2700	0.015		
2760	0.017		
2820	0.016		
2880	0.014		
2940	0.014		
3000	0.014		
3060	0.01		
3120	0.016		
3180	0.024		
3240	0.027		
3300	0.031		
3360	0.032		
3420	0.03		
3480	0.029		
3540	0.029		
3600	0.028		
3660	0.028		
3720	0.028		
3780	0.029		
3840	0.029		
3900	0.028		
3960	0.028		
4020	0.027		
4080	0.027		
4140	0.026		
4200	0.026		
4260	0.025		
4320	0.025		
4380	0.025		

Elapsed Time [s]	Mass [mg/m3]	Alarms	Errors
4440	0.024		
4500	0.024		
4560	0.023		
4620	0.022		
4680	0.022		
4740	0.022		
4800	0.021		
4860	0.02		
4920	0.02		
4980	0.019		
5040	0.018		
5100	0.017		
5160	0.017		
5220	0.024		
5280	0.015		
5340	0.015		
5400	0.013		
5460	0.013		
5520	0.013		
5580	0.012		
5640	0.011		
5700	0.011		
5760	0.01		
5820	0.01		
5880	0.009		
5940	0.008		
6000	0.014		
6060	0.01		
6120	0.006		
6180	0.005		
6240	0.004		
6300	0.003		
6360	0.003		
6420	0.006		
6480	0.002		
6540	0.001		
6600	0.001		
6660	0.001		
6720	0		
6780	0		
6840	0		
6900	0		
6960	0		
7020	0		
7080	0		
7140	0		

Elapsed Time [s]	Mass [mg/m3]	Alarms	Errors
7200	0		
7260	0		
7320	0		
7380	-0.001		
7440	-0.001		
7500	-0.001		
7560	-0.001		
7620	-0.002		
7680	-0.002		
7740	-0.002		
7800	-0.001		
7860	-0.001		
7920	0.006		

Appendix H

Essential Fish Habitat Analysis and Biological Assessment Reports

**ESSENTIAL FISH HABITAT ASSESSMENT ADDRESSING
THE CENTRAL HUDSON GAS & ELECTRIC
CORPORATION FORMER NORTH WATER STREET
MANUFACTURED GAS PLANT REMEDIATION PROJECT
POUGHKEEPSIE, DUTCHESS COUNTY, NY**

U.S. ARMY CORPS OF ENGINEERS

JANUARY 2018

This page intentionally left blank.

Table of Contents

1.	Introduction.....	1-1
2.	Background and Site Description.....	2-1
3.	Remedial Action Description	3-1
3.1	Barrier Wall.....	3-2
3.2	Dredging and Capping.....	3-2
3.3	Regulatory Jurisdiction.....	3-2
3.4	Description of Construction Methods	3-2
3.5	Construction Schedule.....	3-3
4.	Aquatic Environment Adjacent to Site	4-1
4.1	Water Quality.....	4-1
4.2	Tidal Conditions and Salinity	4-2
4.3	Sediment Characteristics.....	4-2
4.4	Significant Coastal Fish & Wildlife Habitats	4-4
4.5	Species in the Project Area	4-4
4.5.1	Benthic Invertebrates	4-5
4.5.2	Spatial and Temporal Fish Distributions	4-1
5.	Managed Species and EFH	5-2
5.1	Atlantic Butterfish.....	5-3
5.2	Atlantic Mackerel.....	5-3
5.3	Atlantic Sea Herring	5-4
5.4	Black Sea Bass.....	5-4
5.5	Bluefish.....	5-5
5.6	Cobia.....	5-6
5.7	King Mackerel	5-6
5.8	Red Hake.....	5-6
5.9	Scup	5-7
5.10	Spanish Mackerel.....	5-7
5.11	Summer Flounder	5-8
5.12	Winter Flounder	5-8
5.13	Windowpane Flounder.....	5-8
6.	Impact Analysis.....	6-1
6.1	Water Column Habitat	6-1

6.2	Benthic Habitat and Invertebrates.....	6-1
6.3	Submerged Aquatic Vegetation and Significant Coastal Fish and Wildlife Habitats.....	6-2
6.3.1	Submerged Aquatic Vegetation.....	6-2
6.3.2	Significant Coastal Fish and Wildlife Habitats.....	6-2
6.4	Fish.....	6-2
6.5	Essential Fish Habitat.....	6-4
7.	Endangered Species Concerns.....	7-1
8.	Mitigation Activities.....	8-1
8.1	Land-based Controls.....	8-1
8.2	Water-based Controls.....	8-1
9.	References.....	9-1

Appendix A Dredging Figures

Appendix B Product Description Sheets – Slope Stabilization Material

List of Figures

Figure 1	Site Vicinity.....	1-2
Figure 2	Existing Conditions.....	2-2
Figure 3	Dredge Areas.....	3-4
Figure 4	Dredge and Capping Areas.....	3-5
Figure 5	Turbidity Curtain (Typical).....	3-6
Figure 6	SSC Concentration South of Poughkeepsie based on USGS data from 2002-2009.....	4-3
Figure 7	Benthic Invertebrate Sample Locations.....	6

List of Tables

Table 1	Benthic Invertebrates – Project Area.....	4-7
Table 2	Summary of Essential Fish Habitat (EFH) Designations.....	5-2

1. Introduction

This Essential Fish Habitat assessment is prepared on behalf of the Central Hudson Gas & Electric Corporation (CHGE) to support the United States Army Corps of Engineers (USACE) Nationwide Permit (NWP) #38 application to conduct work in the Hudson River in compliance with the New York State Department of Environmental Conservation (NYSDEC) *Decision Document* (March 2016) for the Former North Water Street Manufactured Gas Plant (MGP) site (NYSDEC Site No. C314070) in the City of Poughkeepsie, Dutchess County, NY (Figure 1).

The Magnuson Fisheries Conservation and Management Act of 1976 was passed to promote sustainable fish conservation and management. The 1996 amendments to the Magnuson-Stevens Fishery Conservation and Management Act strengthened the ability of the National Marine Fisheries Service (NMFS) and regional councils to protect and conserve the habitat of marine, estuarine, and anadromous finfish, mollusks, and crustaceans. This habitat is termed "essential fish habitat" (EFH) and is broadly defined to include "those waters and substrate necessary to fish for spawning, breeding, feeding, or growth to maturity."

As required by the Magnuson-Stevens Act, the NMFS promulgated regulations to provide guidance to the regional fishery management councils for EFH designation. The regulations further clarify EFH by defining waters to include aquatic areas and their associated physical, chemical, and biological properties that are used by fish, which may encompass a substrate to include sediment, hard bottom, structures underlying the waters, and associated biological contribution to a healthy ecosystem; and areas used for spawning, breeding, feeding, or growth to maturity to cover a species' full life cycle.

This EFH assessment was prepared in compliance with the Magnuson-Stevens Fishery Conservation and Management Act (1996 amendments), Section 7 of the Endangered Species Act of 1973 (as amended), Fish and Wildlife Coordination Act of 2002 (as amended), and under the guidance of the New York District of the USACE.

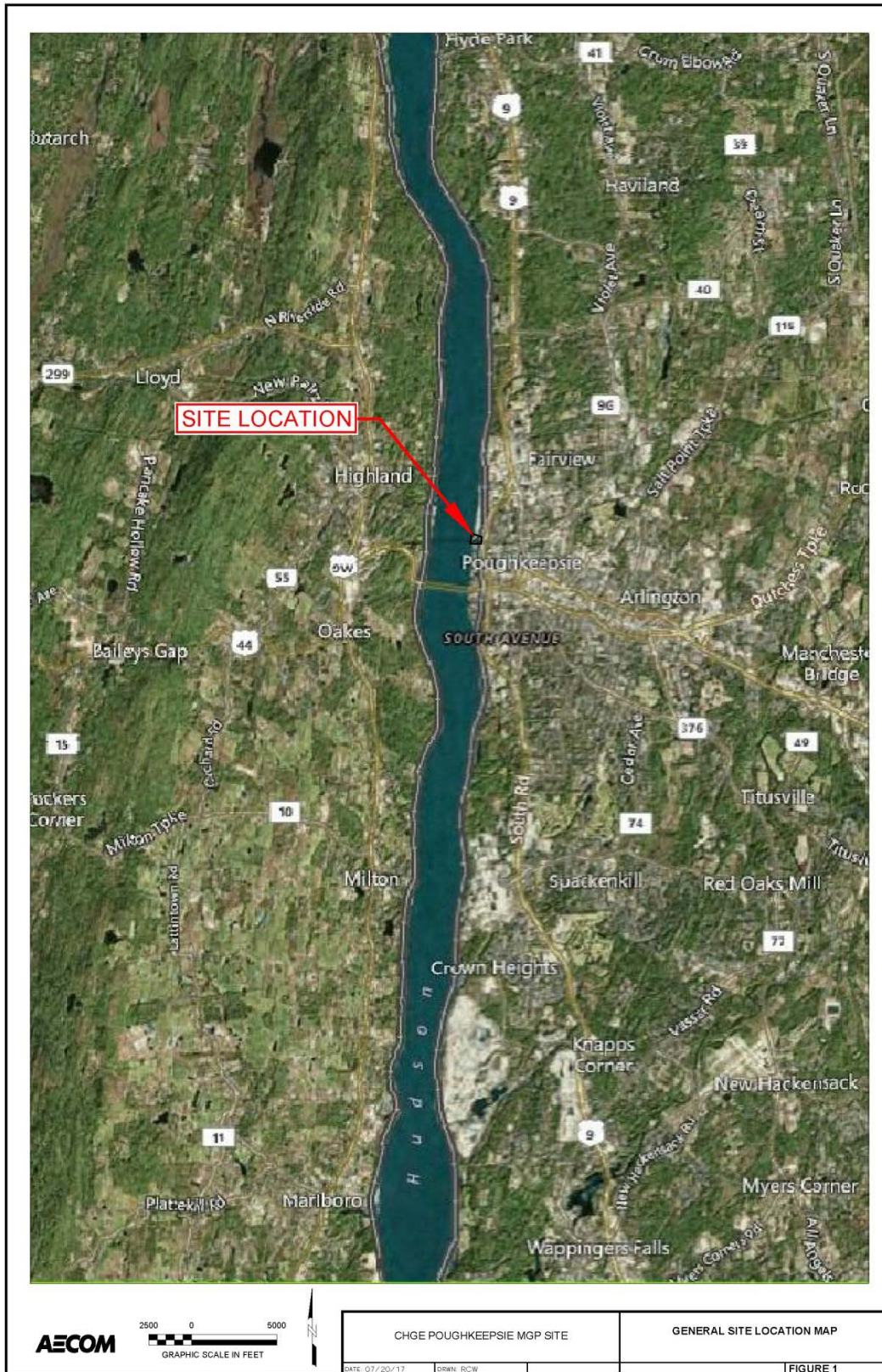

Figure 1 Site Vicinity

2. Background and Site Description

The former North Water Street MGP (site) is located at 2 Dutchess Avenue in the City of Poughkeepsie, Dutchess County, New York. The site is bounded by Dutchess Avenue to the north, North Water Street and Amtrak railroad lines to the east, Upper Landing Park and Fall Kill Creek to the south, and the Hudson River to the west. Tidal movements affect the Hudson River adjacent to the site. Figure 2 depicts the bathymetric contours of the Hudson River adjacent to the shoreline on the CHGE property.

The site was operated as a carbureted water gas MGP from 1911 to 1950. CHGE has owned the site since 1926. During peak operation waste by-products were recycled at the site, and during this process by-products were reported to have seeped into the Hudson River from unintentional spills near the tar separator. To prevent additional seepage of by-products into the river, a clay dike was installed between the railroad siding and the river in the 1940s. Today, residuals from these releases are in the form of non-aqueous phase liquid (NAPL); more specifically dense non-aqueous phase liquid (DNAPL) is the primary form of site contamination to be addressed.

CHGE will perform an environmental remediation at the site per the Brownfield Cleanup Agreement (BCA) Index Number D3-0004-99-04 executed between CHGE and the NYSDEC in May 2005. The NYSDEC-selected remedy to address the environmental impacts identified at the site and in the Hudson River adjacent to the site is presented in the March 2016 Decision Document.

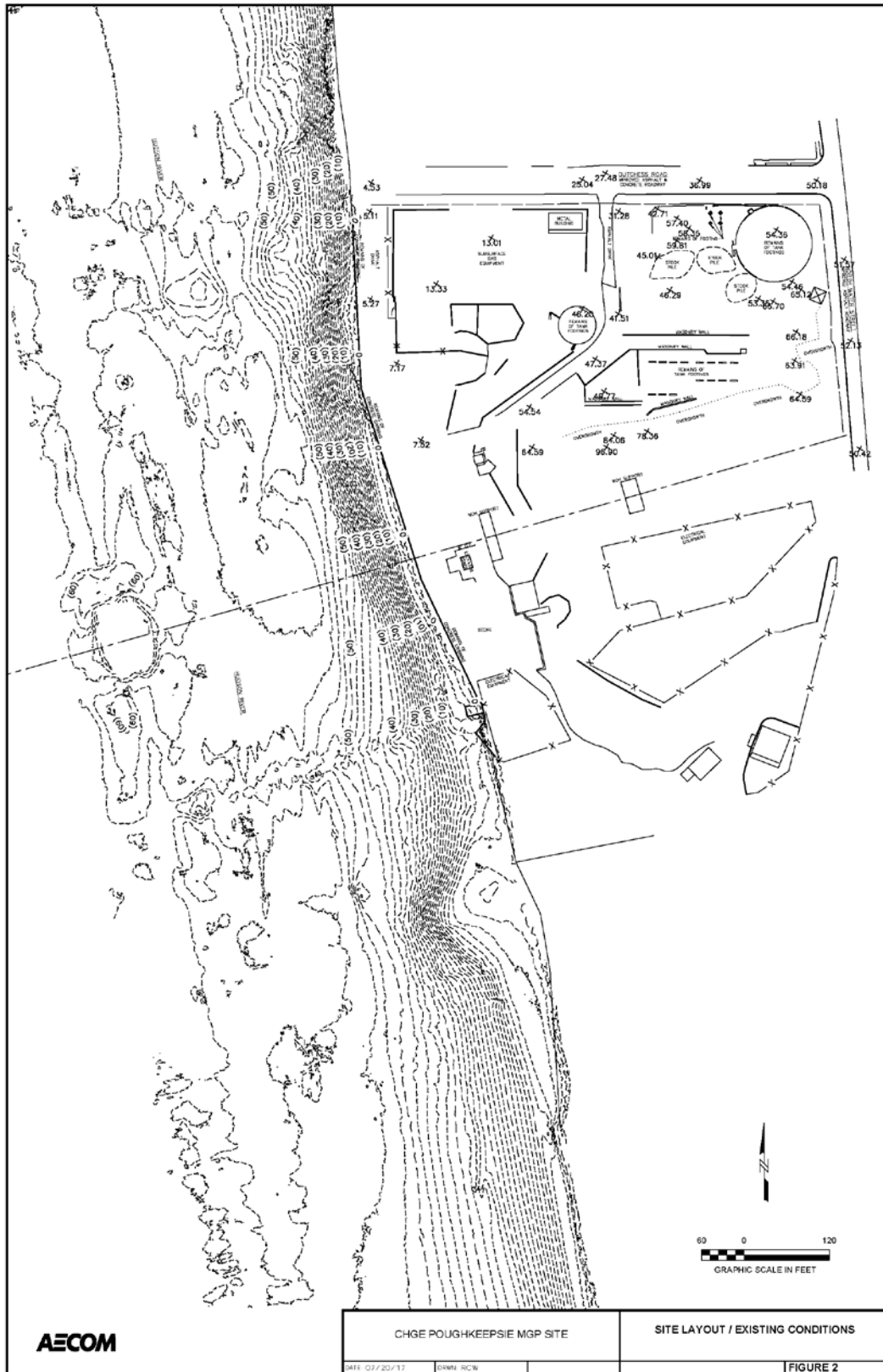

Figure 2 Existing Conditions

3. Remedial Action Description

The selected remedy for the site as documented in the NYSDEC Decision Document (NYSDEC 2016) includes:

- Excavation and off-site disposal of upland contamination from the source areas located in the northern portion of the lower terrace areas of the site (not part of this permit application).
- Installation of a subsurface barrier wall along the east bank of the Hudson River to prevent migration of coal tar to the River (not part of this permit application).
- Installation of a series of NAPL recovery wells behind the barrier wall to collect DNAPL that might accumulate behind the wall. NAPL will be collected from these recovery wells periodically (not part of this permit application).
- Installation of a NAPL recovery well in the area north of the barrier wall where the natural gas pipeline enters the upland portion of the site, which precludes the safe construction of the barrier wall. Initially in-situ solidification (ISS) was proposed for this area, but due to small size of this area, ISS is not practical. Installation of a NAPL recovery well in lieu of ISS in this area was presented to the NYSDEC during a meeting on November 8, 2017 to capture any NAPL that may be migrating towards the Hudson River (not part of this permit application).
- Dredging of NAPL impacted sediments from the bed of Hudson River where feasible.
- Placement of cover system consisting of Reactive Core-Mats (RCM) overlain by armored concrete blocks over the impacted sediment areas near and above the underwater utility crossings, where dredging cannot be performed.
- Placement of articulated capping system consisting of RCM with grout filled molds over the riverbank slope immediately adjacent to the site where dredging would create significant safety concerns due to potential for slope instability. The capping system will prevent migration of the remaining contamination in the riverbank into the Hudson River.
- Placement and maintenance of the cover system over the site to allow for industrial use of the site. The cover system will consist of structures, pavements, or soil cover in areas where the exposed soil will exceed the applicable Soil Cleanup Objectives (SCOs) (not part of this permit application).
- River and riverbank restoration that incorporate measures to maximize wildlife habitat while protecting energy infrastructure and allowing for potential future development of a public access walkway along the riverbank.
- Establishing institutional controls in the form of an environmental easement for the upland portion of the site. Institutional controls in the upland areas would be established to limit subsurface intrusive activities that could result in potential exposure to soil and groundwater, limit the use of the site, prohibit the use of the site groundwater, and require compliance with the Site Management Plan (SMP) (not part of this permit application).

- Preparing a SMP to document institutional controls, known locations of soil and sediments containing NAPL impacts, protocols for conducting intrusive activities, protocols for periodic monitoring, and reporting requirements(not part of this permit application).

Of the remedial activities listed above, the dredging and capping activities in the Hudson River and along the river side slope are subject to NWP 38 and described here. Approximately 7.6 acres of dredging (Figure 3) would be conducted to remove approximately 40,000 cubic yards (CYs) of sediment impacted by the operation of the former MGP facility. Dredging of sediments that are visually impacted with NAPL from the areas identified on Figure 3 is proposed to be conducted between October 2018 and February 2019.

3.1 Barrier Wall

To prevent migration of coal tar to the river, installation of a subsurface barrier wall along the east bank of the Hudson River will be conducted. Subsequently, there will be the installation of a series of NAPL recovery wells to collect NAPL that might accumulate behind the wall. NAPL will be collected from these recovery wells periodically.

3.2 Dredging and Capping

To remove NAPL impacted sediments from the bed of Hudson River, dredging will be conducted where feasible (Figure 3). A full set of dredging figures that depicts the various dredge areas, capping and methods is provided in Appendix A. A sand cap will be placed in select dredged areas. In areas of impacted sediment near and above the underwater utility crossings, where dredging cannot be performed, the placement of cover system consisting of RCM overlain by armored concrete blocks will be conducted (Examples of sediment/slope stabilization materials are provided in Appendix B).

In areas of impacted sediment along the riverbank slope where dredging would create significant safety concerns due to slope instability, an articulated capping system will be placed consisting of RCM with grout filled molds (Appendix B). The capping system will prevent migration of the remaining contamination in the riverbank into the Hudson River.

3.3 Regulatory Jurisdiction

The dredging and capping activities in the Hudson River and along the river shoreline slope are subject to the jurisdiction of the USACE. Approximately 7.6 acres of dredging (Figure 3) would be conducted in the Hudson River to remove approximately 40,000 CYs of sediment impacted by the operation of the former MGP facility. There would also be approximately 1.2 acres of capping along the riverbank slope (Figure 4).

3.4 Description of Construction Methods

Dredging will be conducted using an environmental bucket within a containment cell. The containment cell will be attached to the dredge barge which will be outfitted with turbidity curtains and floating booms on all sides of the dredge polygon (Figure 5) to control the transport of contaminated sediment beyond the

dredging area. Water quality (turbidity) will be monitored for the duration of the dredging by means of three buoy-mounted remote sensing stations that will be moored around the perimeter of the work area.

Dredged areas deeper than 2 feet below the existing bathymetry will be backfilled after dredging with certified clean sand (approximately 31,000 CYs) imported from upland sources and transported to the site via barge. The clean sand will be placed on approximately 4.2 acres of the dredged areas using specially fabricated conveyors and tremie technology that will discharge the sand from a tremie pipe. To the extent practicable and constructible, the tremie pipe will extend to the dredge surface. The clean sand backfill will be placed in the dredged areas to within 2 feet of the adjacent bottom elevation to support the restoration of the river bottom to pre-dredge bathymetry. The sand will consist of a granular material of sufficient size and density that is expected to fall through the portion of the water column beyond the tremie pipe to the river bottom at its placement location with minimal dispersion. Clean sand was selected specifically to maximize accuracy of the fill placement operation and minimize suspension and transport of backfill material outside of the intended placement location.

The river bottom will be allowed to reestablish its original (pre-dredging) bathymetry within the dredged areas by natural sediment transport processes. Sediment deposition and subsequent erosion is a natural cycle within a stable riverbed; while specific rates of sedimentation and erosion in the vicinity of Poughkeepsie are not available, sedimentation rates of approximately 40 centimeters (1.3 feet) within a period of months (typically, during the spring freshet) are observed within the Lower Hudson River as a whole. Dredging of the impacted sediment will create areas of the river bottom below the surrounding bathymetry and function as natural sediment traps; consequently, it is expected that sediment transport within the dredged areas will only be depositional in nature until the pre-existing stable bathymetry is restored, after which the natural long-term deposition and erosion cycle will resume.

The slope of the shoreline along the site cannot be dredged to remove impacted sediment due to the shallow depth and stability issues with the slope. A subsurface steel sheet pile wall will be installed as part of the upland and bulkhead remediation activities. To isolate the impacted sediment remaining beyond the sheet pile bulkhead wall from the river, approximately 1.22 acres of an articulated capping system consisting of RCM with grout filled molds will be installed along the river slope. This will require a cut volume of approximately 1,722 CYs and a backfill volume of approximately 6,775 CY (Appendix A provides all related dredging figures and details, including slope and sediment stabilization materials).

Since dredging cannot be conducted in the area of the existing underwater gas, electric, and fiber optic lines that extend across the Hudson River, approximately one acre area near and over the utility crossings will be capped with a cover system consisting of RCM overlain by armored concrete blocks to isolate the impacted sediment in these areas (Figure 4).

3.5 Construction Schedule

Dredging of the contaminated sediment is proposed to be conducted between October 2018 and February 2019. Additionally, the less intrusive capping of the underwater utility areas and river bank slope is anticipated to be conducted between July 2019 and September 2019, after the published key migratory spawning season (March 1 through June 30).

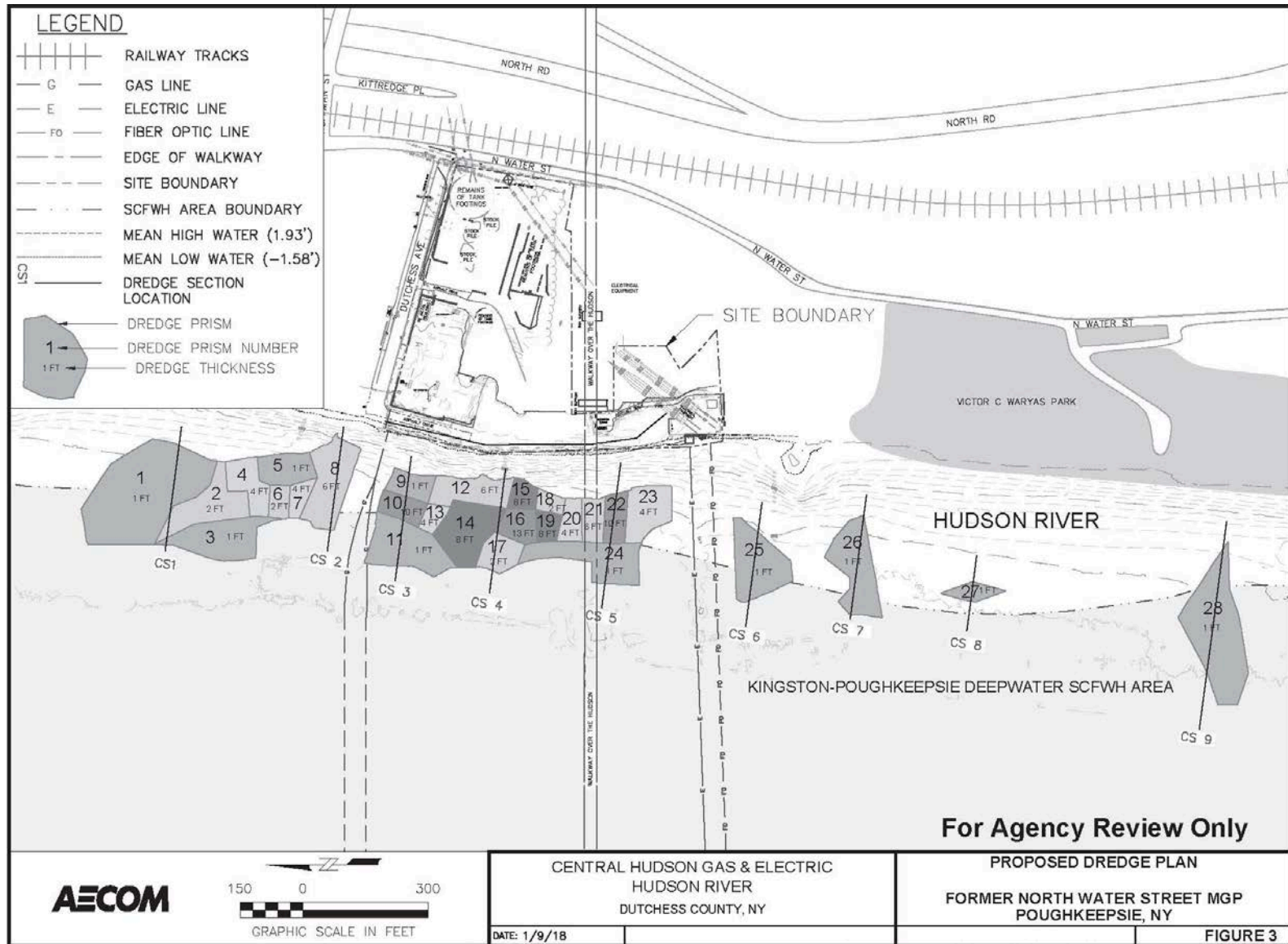

Figure 3 Dredge Areas (Proposed Dredge Plan)

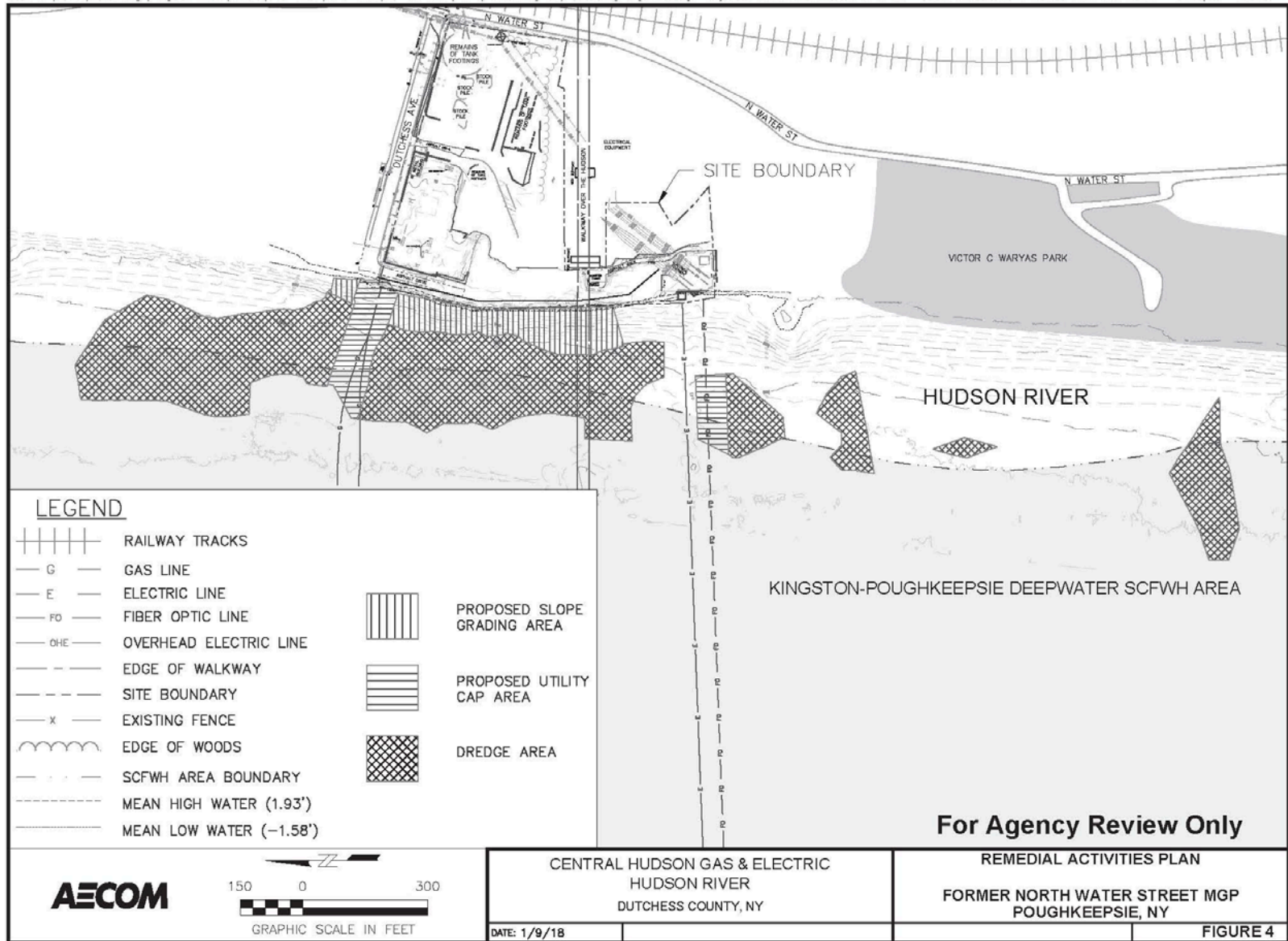

Figure 4 Dredge and Capping Areas

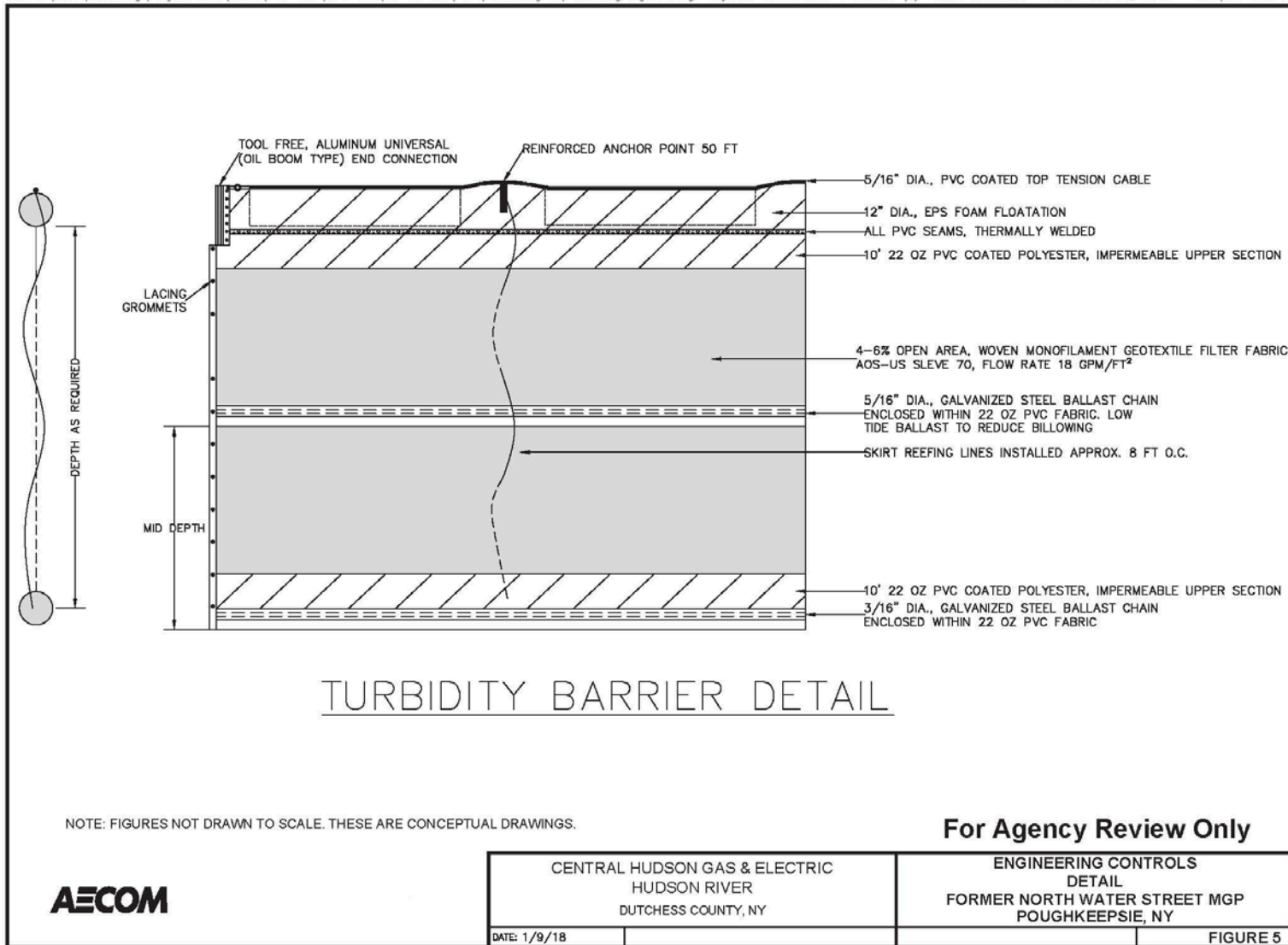

Figure 5 Turbidity Curtain (Typical)

4. Aquatic Environment Adjacent to Site

The site is located on the Hudson River, approximately 83 river miles (RM) north of New York Harbor, and 75 RM below the Federal Dam in Troy. The Hudson River is tidal below the Federal Dam.

4.1 Water Quality

The water quality classification at the project site is a driving factor in assessing project impacts. The Hudson River near the site is classified by NYSDEC as Class A fresh surface water. Class A waters are a source of water supply for drinking, culinary or food processing purposes, primary and secondary contact recreation, and fishing. The waters are suitable for fish, shellfish and wildlife propagation and survival (6 NYCRR Part 701.6). The water quality classification for Fall Kill Creek where it borders the southern portion of the site is Class C fresh surface water. The best usage of Class C waters is fishing, with suitability for primary and secondary contact recreation with potential limits.

The parameters typically associated with suspended sediments, such as turbidity or total suspended solids (TSS), colloidal, and settleable solids, do not have numeric water quality standards (6 NYCRR Part 703.2). However, the narrative standards state that an action should not increase turbidity sufficiently to result in a substantial visible contrast to natural conditions, or any suspended, colloidal or settleable solids from sewage, industrial or other wastes that would cause deposition or impair the waters for their best use.

The Hudson River Estuary (HRE) is well studied and a significant number of data sources exist. A United States Geologic Survey (USGS) gauge south of Poughkeepsie (approximately four miles downstream of the site) continuously monitors suspended sediment concentration (SSC) as well as water quality parameters. The USGS gauge south of Poughkeepsie uses backscatter information from an acoustic Doppler current profiler (ADCP) to estimate suspended solids concentration (Wall et al., 2006). Using the SSC estimates combined with the current data measured by the device, an estimate of total sediment discharge is also calculated.

The Hudson River Environmental Conditions Observing System (HRECOS) is an environmental monitoring network in the Hudson River watershed. HRECOS monitoring stations are equipped with sensors that continuously record a variety of water quality and weather parameters every 15 minutes, with most stations operating year-round. Remote telemetry at each station transmits real-time data for the public to freely view and download using an easily-accessible interface at hrecos.org. A HRECOS station is located approximately one half mile upstream of the site at Marist College in Poughkeepsie (HRECOS, 2017).

Available guidance and precedent suggest that the suspended solids concentrations in a project area do not need to be rigorously defined, as (1) water quality standards for suspended solids are typically defined in relative rather than absolute terms, and (2) existing background conditions do not materially alter the behavior of sediments resuspended by project-related activities. However, for the purposes of impact evaluation, a concept of the typical sediment concentrations at the project site, and their variability, is still useful. To aid in this understanding the yearly variation at the USGS gauge south of Poughkeepsie is presented in Figure 6.

The HRE has a long history of environmental disturbance, including shoreline modifications, dredging impacts/channelization, and pollution. Many habitats are impacted or threatened by toxic chemicals, increased sedimentation and turbidity, and non-point source pollution from agricultural and residential watersheds. Treated sewage effluent is discharged into many Hudson River tributaries by towns and villages. Many older municipalities have aging sewage treatment systems with clay pipes, along with inadequate pump stations and treatment plants. This decaying infrastructure permits raw sewage to enter the estuary under conditions of heavy rainfall (Cooper et al., 1988). However, recent funding initiatives, authorized by the New York State Clean Water/Clean Air Bond Act of 1996, have made significant progress towards improvement of older wastewater infrastructure in many municipalities along the Estuary (NYSDEC, 2005).

4.2 Tidal Conditions and Salinity

The Hudson River is tidally influenced from the Battery to the Federal Dam at Troy, NY, 153 miles north. Tides at the Battery have an average range of 4.5 feet, with the mean range decreasing to 3.1 feet at Poughkeepsie and gradually increasing again to 4.7 feet at the Federal Dam (NOAA, 2016). The majority of freshwater flow enters the Hudson River north of the Federal Dam at Troy, with the remaining freshwater flow entering from various tributaries downstream of the dam. Freshwater flow in the Hudson estuary follows a typical seasonal pattern, with highest flow during the spring and lowest flow during late summer and early fall. Water temperatures measured near the site range from -0.10 degrees Celsius in the winter to 28.8 degrees Celsius in the summer based on monitoring gauges near the site (USGS, 2017a; HRECOS, 2017).

Although the reach of the Hudson River that is adjacent to the site is classified as freshwater, saline water is still present upstream of the site. The mid-estuary from Stony Point to Poughkeepsie is generally the oligohaline zone (0.5 to 5 parts per thousand salinity) in the Hudson, including the seasonal inland extent of brackish water in the Hudson, although the limits of this zone change with the amount of freshwater flow (USFWS, 1997). The extent of the salt front (the location at which the chloride concentration equals 100 milligrams per liter) generally occurs in the southern part of the Hudson River but may reach as far north as Poughkeepsie during very dry years (USGS, 2017b).

4.3 Sediment Characteristics

In December of 2017, a sediment sampling and benthic invertebrate sampling program occurred within the dredge prisms and river bank slope. Sediments were generally comprised of silts that have been affected by the presence of NAPL. Also, in isolated locations gravels, woody detritus and other materials were encountered. These materials are likely surficial in nature and associated with prior bridge construction and other industrial activities in the greater project area.

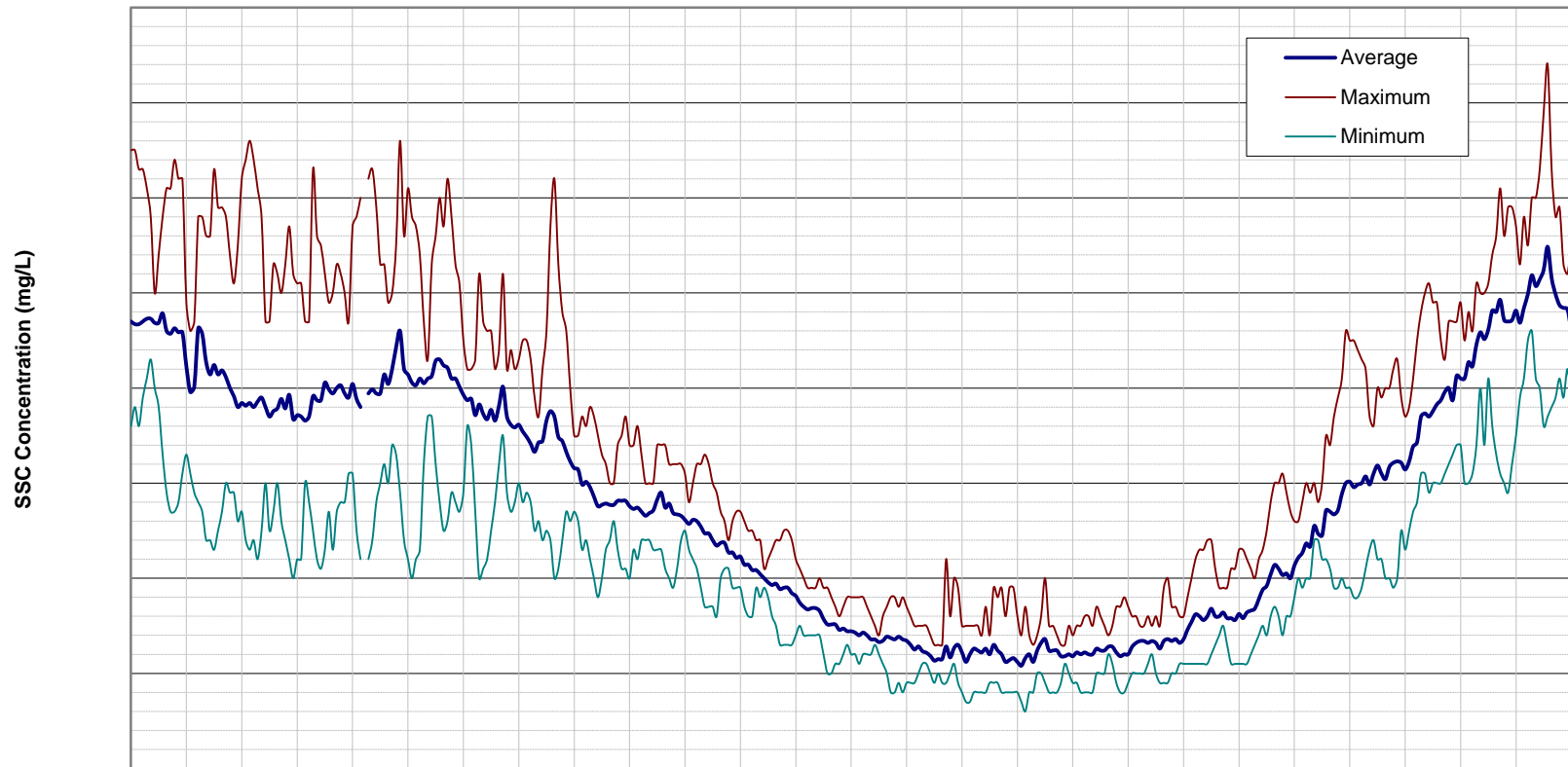

Figure 6 SSC Concentration South of Poughkeepsie based on USGS data from 2002-2009

4.4 Significant Coastal Fish & Wildlife Habitats

The Kingston-Poughkeepsie Deepwater Habitat is an approximately 6,350 acre habitat that encompasses a 25 mile stretch of the Hudson River extending approximately from Kingston Point in the City of Kingston in Ulster County and the Village of Rhinecliff in Dutchess County to just south of Wappinger Creek in the Town of Wappinger in Dutchess County. This habitat area is a nearly continuous Deepwater section of the river, from a water depth of 20 feet to the bottom, and especially where water depths of 50 feet or greater occur. The Kingston-Poughkeepsie Deepwater Habitat is the northernmost extensive section of deepwater habitat in the Hudson River. The Kingston-Poughkeepsie Deepwater habitat has been designated as a Significant Coastal Fish and Wildlife Habitat (SCFWH) by the NYSDEC (NYSDOS, 2012). Dredging in the SCFWH area of approximately 25,000 CYs within approximately 4 acres will be conducted using an environmental bucket within a containment cell which will be outfitted with turbidity curtains that extend to the river bottom and floating booms on all sides to control turbidity beyond the dredging area.

Deepwater areas provide wintering habitat for shortnose sturgeon and support a diversity of marine species in the Hudson River. The Kingston-Poughkeepsie Deepwater Habitat is believed to be the northernmost wintering location of shortnose sturgeon in the Hudson River. Recent fisheries investigations of the Hudson River indicate spawning as well as wintering of sturgeon in this area. Although habitat requirements of this species in the Hudson River are not well known, it is believed that these deepwater areas may be critical year round. Shortnose sturgeon use the portion of the river which generally is greater than 30 feet in depth. This area is also significant since it is largely responsible for the abundance of marine species upriver (the northern range limit for many in New York), especially during periods of low freshwater flows (summer). During the spring spawning run of shad, commercial drift netting takes place in the surface waters overlying this area (NYSDOS, 2012).

4.5 Species in the Project Area

The fish populations of the HRE are well studied. For 35 years, area utility companies have been performing seasonal sampling of various life stages throughout the river. In addition, federal and state regulatory agencies, such as National Oceanic and Atmospheric Administration (NOAA), and NYSDEC, as well as independent researchers (e.g., Pisces Conservation LTD, 2008; Heimbuch, 2008, etc.) have published numerous reports on the river's fisheries resources.

Over 200 species of fish have been noted within the Hudson River estuary according to the NYSDEC (NYSDEC, 2017). A total of 48 species of fish were observed during the 2017 NYSDEC “*Great Hudson River Estuary Fish Count*” at Waryas Park (located approximately one-half mile downstream of the project site). While not an exhaustive list of species occurring in the project area, the species noted below were collected on August 5, 2017 via seining operations conducted from shore as part of an educational event: blueback herring (*Alosa aestivalis*), American shad (*Alosa sapidissima*), golden shiner (*Notemigonus crysoleucas*), spotfin shiner (*Cyprinella spiloptera*), spottail shiner (*Notropis hudsonius*), shiner species, white sucker (*Catostomus commersonii*), banded killifish (*Fundulus diaphanous*), striped bass (*Morone saxatilis*), rock bass (*Ambloplites rupestris*, *Ambloplites constellatu*), red-breasted sunfish (*Lepomis auritus*), pumpkinseed (*Lepomis gibbosus*), smallmouth bass (*Micropterus dolomieu*), largemouth bass (*Micropterus salmoides*), tessellated darter (*Etheostoma olmstedii*), yellow perch (*Perca flavescens*), and

logperch (*Percina caprodes*). Of these, the majority of fish caught were young of the year, including all of the individuals of migratory species.

4.5.1 Benthic Invertebrates

The zebra mussel (*Dreissena polymorpha*) is known to occur in and near the Hudson River from Albany to Haverstraw Bay (United States Fish and Wildlife Service [USFWS] 1997). Zebra mussels are filter feeding bivalves capable of achieving significant filtration rates, which reduce available water column food chain production (USFWS 1997). Reduction in phytoplankton and detritus volumes may reduce the zooplankton species that feed upon them and could result in localized fisheries-related impacts (USFWS 1997). However, the sediments that contain these detritus material in the areas where dredging will be conducted are heavily impacted with NAPL and harmful to the zebra mussels and other species mentioned above.

Benthic communities vary in distribution depending on bottom water salinity, with a typically marine benthos from Stony Point south dominated by marine worms and crustacea, a mixture of freshwater and marine organisms between Stony Point and Poughkeepsie, and freshwater snails, clams, chironomids, and insects north of Poughkeepsie (USFWS, 1997).

In December 2017, sampling to identify benthic invertebrates was conducted in the project area. Benthic samples were obtained through the use of a Van Veen Grab sampler. The grab collected sediments from the Hudson River bottom. The grab sample was then brought to the surface and the sediments were washed away over a screen table. The remaining contents were then placed in a container with a preservative and biological stain. Later, the remaining materials were examined with a microscope and all species were identified to the lowest possible taxon. Nine mid-stream, three shoreline and two reference locations were sampled (Figure 7).

As can be observed in Table 1 below, a typical assemblage of Hudson River benthic invertebrates were observed in both the dredge prism areas and the two reference locations¹. Due to composition substrate along the shoreline, two of the three shoreline sites were unable to produce fine-grained sediment samples, and at the one that collected a sample only zebra mussels and one blue mussel shell was observed. The zebra mussel, an invasive species, was observed at several locations. Blue mussel shell fragment were observed at several sample locations, but only the two reference sites and Location 27 samples yielded any live species. Some amphipods were observed at most sites but were not observed at either of the reference sites. Other species observed in small quantities at some sites include isopods, clams, midge larvae, American eel, and snails, although often samples contained only fragments rather than live specimen. Many of the samples exhibited a strong odor or sheen, likely as a result of historic contamination.

¹ Reference Locations 1 was located approximately 2,500 feet north of Dutchess Avenue off the eastern shoreline. N 41.718205, W -73.939893

Reference Location 2 was located approximately 2,900 feet northwest of Dutchess Avenue off the western shoreline. N 41.716921, W-73.948095

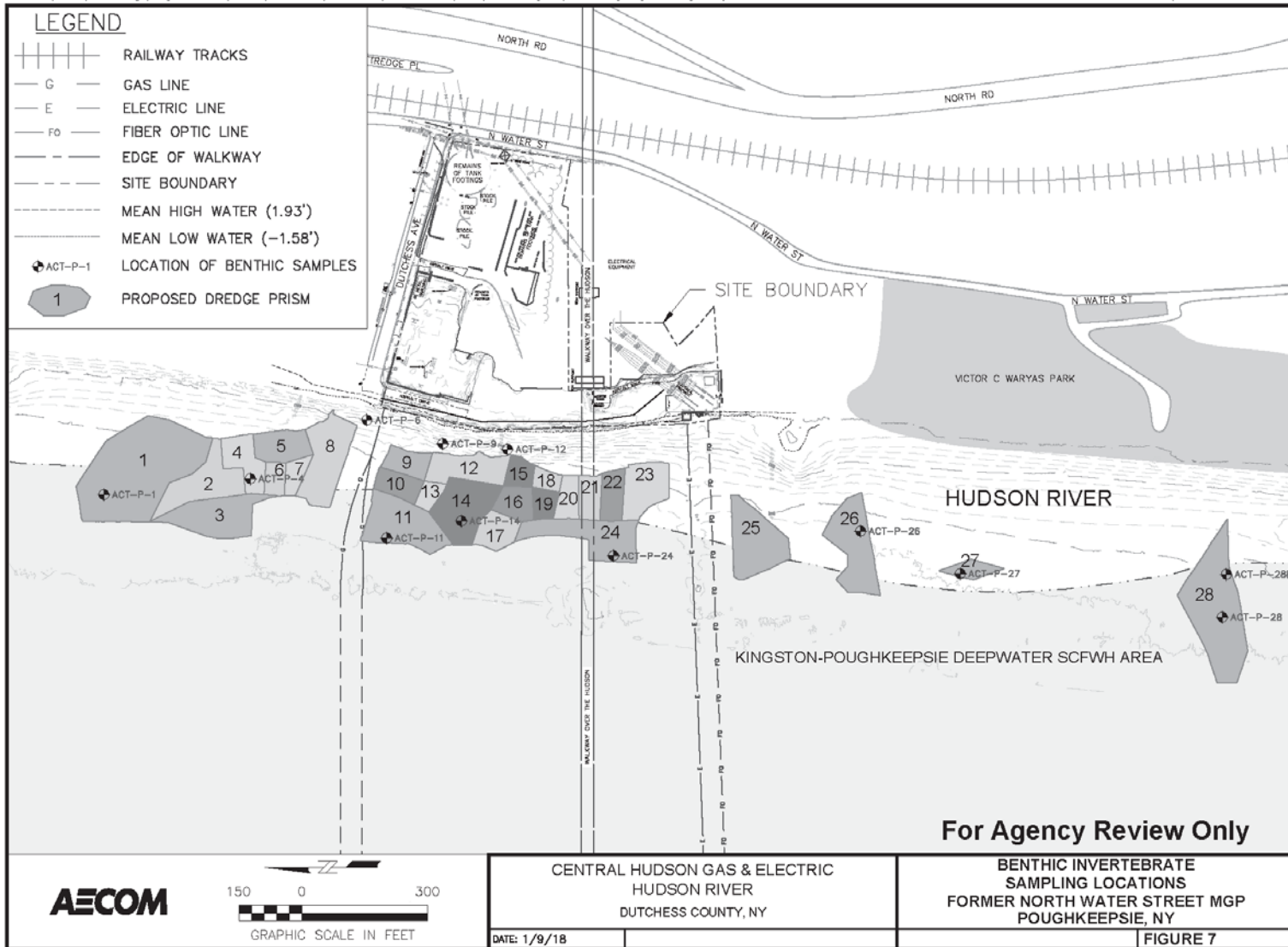

Figure 7 Benthic Invertebrate Sample Locations

Table 1
Benthic Invertebrates – Project Area

Site ^a	Depth ^b (feet below surface)	Substrate Composition	Zebra mussel ^c (<i>Dreissena polymorpha</i>)	Amphipod (<i>Gammaridea</i> sp.)	Slender Isopod (<i>Cyathura</i> sp.)	Asian clam (<i>Corbicula</i> sp.)	Midge larvae (<i>Chironomidae</i> sp.)	Blue mussel (<i>Mytilus edulis</i>)	American eel (<i>Anguilla rostrata</i>)	Insecta sp.	Bivalve sp.	Faucet snail (<i>Bithynia tentaculata</i>)	Gastropod sp.	Other
ACT-P-1	54	Silt, some coarse sand and leaf litter.	20	1										Woody detritus, some black grit, few pieces of gravel. 1 hogchoker flounder.
ACT-P-4	55	Silt, some coarse sand and leaf litter.	10	5				1 SF						Woody detritus with some leaves. Sheen and odor.
ACT-P-11	60	Silt.	25											Woody detritus with some black grit. Sheen and odor.
ACT-P-14	53	Silt, some coarse sand.	15	4		1	2		1					Woody detritus with some tar blobs. Some sheen.
ACT-P-24	56	Silt, some gravel, some coarse sand, shells, rock and brick fragments.	205	3				1 SF						Some gravel with slag, coarse sand and black grit. Strong odor.
ACT-P-26	53	Silt, some gravel and coarse sand.	23			2	1				1 SF			Some gravel, coarse sand and black grit. Woody detritus, gravel and slag. Sheen and odor.
ACT-P-27	58	Silt, some shells.	210					4 live, 3 SF						Gravel, slag, some black grit. Sheen and odor.
ACT-P-28	52	Silt, some shells.	126	2		3 SH	2	1 SF	1	1 WF				Woody detritus with some coarse sand, black grit and shell fragments.
ACT-P-28B	55	Silt, some shells.	300	7	1			6 SF						Gravel, some slag, coarse sand and grit.
ACT-P-12	25	Refusal, no sample collected. 1 large stone encrusted with zebra mussels.											No sample collected.	
ACT-P-9	30	Refusal, no sample collected.											No sample collected.	
ACT-P-6	20	Silt, some coarse sand and gravel.	25					1 SF				1		Rocks, gravel, slag, coarse sand, and black grit, some woody detritus.
Reference 1	51	Silt, some shells.	21			1	1	1 live, 2 SF						Gravel with coal, slag, coarse sand, black grit, and woody detritus. Some sheen.
Reference 2	35	Silt.	300					1 live				1	1 EF	Woody detritus with some black grit, gravel, sticks, slag, and coarse sand.

Notes: Three samples were collected at each site location. Results show the aggregate of the three samples.

- a. Indicates the average depth of the three samples.
- b. Zebra mussel counts include shells and fragments.
- c. SF = Shell Fragment; SH = Shell; WF = Wing Fragment; Eroded/Fossilized Shell

Also, within the dredge prisms, some of the benthic habitat would be considered impaired as it contains NAPL or other debris materials. This may contribute to the lack of abundance or diversity in many of the samples.

4.5.2 Spatial and Temporal Fish Distributions

Due to the long length of the river, and inputs of freshwater from tributaries and tidal actions, the salinity levels are not homogeneous throughout the estuary. Seasonal variations in temperature and precipitation levels alter the levels of salinity within the estuary. The northern portions of the river are freshwater, but are influenced by tidal action, so that the lower portion of the Hudson River is a dynamic system that witnesses dramatic fluctuations in species diversity and biomass from season to season. Within the project area, salinities are generally less than 5 parts per thousand (ppt), which would exclude the presence of many marine and estuarine species.

5. Managed Species and EFH

To delineate EFH, coastal littoral and continental shelf waters were first mapped by the regional FMCs and then superimposed within ten minute-by-ten minute (10' x 10') square coordinate grids. Finally, survey data, gray literature, peer-review literature, and reviews by academic and government fisheries experts were all used by the FMCs to determine whether these 10' x 10' grids support EFH for federally managed species. The Mid-Atlantic Fisheries Management Council (MAFMC) has designated EFH in the lower portion of the Hudson River.

Review of the National Oceanographic and Atmospheric Administration (NOAA) "Summary of Essential Fish Habitat (EFH) Designation" for the Hudson River indicates that up to 13 federally managed species may utilize the Hudson River for part or all of their life history (Table 2). However, four listed species (summer flounder, king mackerel, Spanish mackerel, and cobia) were noted as primarily marine species.

A description of the life history and use of the Hudson River for each species listed in Table 2 is provided below.

Table 2
Summary of Essential Fish Habitat (EFH) Designations

Species	Eggs	Larvae	Juveniles	Adults	Spawning Adults
Red hake (<i>Urophycis chuss</i>)		M,S	M,S	M,S	
Winter flounder (<i>Pleuronectes americanus</i>)	M,S	M,S	M,S	M,S	M,S
Windowpane flounder (<i>Scophthalmus aquosus</i>)	M,S	M,S	M,S	M,S	M,S
Atlantic sea herring (<i>Clupea harengus</i>)		M,S	M,S	M,S	
Bluefish (<i>Pomatomus saltatrix</i>)			M,S	M,S	
Atlantic butterfish (<i>Peprilus triacanthus</i>)		M	M,S	M,S	
Atlantic mackerel (<i>Scomber scombrus</i>)			S	S	
Summer flounder (<i>Paralichthys dentatus</i>)		F,M,S	M,S	M,S	
Scup (<i>Stenotomus chrysops</i>)	S	S	S	S	
Black sea bass (<i>Centropristus striata</i>)			M,S	M,S	
King mackerel (<i>Scomberomorus cavalla</i>)	X	X	X	X	
Spanish mackerel (<i>Scomberomorus maculatus</i>)	X	X	X	X	
Cobia (<i>Rachycentron canadum</i>)	X	X	X	X	
Notes: n/a = Species either have no data available on the designated lifestages, or those lifestages are not present in the species' reproductive cycle.					

Species	Eggs	Larvae	Juveniles	Adults	Spawning Adults
<p>M = The EFH designation for this species includes the mixing water/ brackish salinity zone of the HRE (0.5% < salinity < 25.0%). S = The EFH designation for this species includes the seawater salinity zone of the HRE (salinity > or = 25.0%). F = The EFH designation for this species includes the tidal freshwater salinity zone of the HRE (0.0% < or = salinity < or = 0.5%). X = All areas of the river are classified as EFH.</p> <p>Source: NOAA, 2017</p>					

5.1 Atlantic Butterfish

The Atlantic butterfish (*Peprilus tricanthus*) ranges from Newfoundland to Florida, but is primarily found from the Gulf of Maine to Cape Hatteras. Butterfish migrate in response to seasonal changes in water temperature. During summer, butterfish move northward and inshore to feed and spawn. Spawning occurs during June to August and peaks progressively later at higher latitudes. During winter, butterfish move southward and offshore to avoid cool waters. Butterfish are primarily pelagic and form loose schools that feed upon small fish, squid, and crustaceans.

Butterfish have a high natural mortality rate and are preyed upon by many species, including silver hake, bluefish, swordfish, and long-finned squid. The NMFS has designated the salinity zone of Hudson River as EFH for Atlantic butterfish larvae and the mixing and salinity zones as EFH for butterfish juveniles and adults. It is unlikely that butterfish occur in the project area due to the low salinities.

5.2 Atlantic Mackerel

The Atlantic mackerel (*Scomber scombrus*) is a fast-swimming, pelagic, schooling species distributed in the northwest Atlantic between Labrador and North Carolina and are primarily found in the open sea (although rarely beyond the continental shelf) from Black Island, Labrador (Parsons 1970) to Cape Lookout, North Carolina (Collette and Nauen 1983). Eggs, larvae and juveniles also found at varying levels of abundance in bays and estuarine areas from New Jersey north through New England and into Canadian waters. Atlantic mackerel are opportunistic feeders that can ingest prey either by individual selection of organisms or by passive filter feeding (Pepin et al. 1988).

This population has two major spawning components: a southern group that spawns primarily in the Mid-Atlantic Bight during April and May, and a northern group that spawns in the Gulf of St. Lawrence in June and July. Both groups winter between Sable Island (off Nova Scotia) and Cape Hatteras in waters generally warmer than 45° F (7° C), with extensive northerly (spring) and southerly (autumn) migrations to and from spawning and summering grounds. The eggs are pelagic in water over 34 ppt, floating in surface waters above the thermocline or in the upper 10 to 15 meters.

Regulations on landings of Atlantic mackerel were enforced in 1976 in hopes of reducing fishing effort so as to ensure reproductive success in the population by keeping spawning stock levels above devastating levels. Recruitment has increased since 1976-1980 and strong year classes were evident in 1982, 1987, 1988, and 1990-1993 (Northeast Fisheries Science Center 1996). The NMFS has designated the Hudson River salinity zone as EFH for Atlantic mackerel juveniles and adults. It is unlikely that mackerel occur in the project area due to the low salinities and distance from the Atlantic Ocean.

5.3 Atlantic Sea Herring

The Atlantic herring (*Clupea harengus*) is a pelagic, schooling, plankton-feeding species that inhabits both sides of the North Atlantic Ocean. Atlantic herring are usually seen swimming in vast schools offshore (Geiser, 1984). In the western North Atlantic this species ranges from Labrador to Cape Hatteras and supports major commercial fisheries. Adult herring undergo complex north-south migrations for feeding, spawning, and overwintering. Herring produce demersal eggs and spawn during the summer and fall in the Gulf of Maine – Georges Bank region. Larvae overwinter offshore and in coastal waters and metamorphose into juveniles in the spring. Juveniles and adults are heavily preyed upon by a variety of marine fish, marine mammals, and seabirds (NOAA, TM 192, 1999). Eggs are demersal and are typically deposited on gravelly substrates (Reid et al., 1999).

In 1999, the NOAA Technical Memo for the species indicated that the U.S. stock complex has fully recovered from the effects of over-exploitation during the 1960s and 1970s and is currently under-utilized, although there is concern that exploitation rates in the Gulf of Maine may be too high. The NMFS has designated the Hudson River mixing and salinity zone as EFH for Atlantic sea herring larvae, juveniles, and adults. Due to the geographical location of the project area, it is unlikely that herring adults, larvae, or eggs would be present in the project area.

5.4 Black Sea Bass

Black sea bass (*Centropristus striata*) are strictly confined to salt water, appearing inshore during the first or second week in May and withdrawing again late in October or early in November. The substrate preferred by the black sea bass generally consists of shellfish and eelgrass beds, man-made structures in sandy-shelly areas, and offshore clam beds (Bigelow and Schroeder, 1953). Although, young of the year (YOY) fish also occur in large numbers in structurally complex estuarine habitats (NOAA TM 200, 2007). During the part of the year when the black sea bass are inshore they are most plentiful on hard bottom, in water depths of less than 115 feet (35 m) or so, often around submerged wrecks. They are bottom feeders, subsisting chiefly on crabs, lobsters, shrimp, and various mollusks (Bigelow and Schroeder, 1953).

Juvenile and adult black sea bass occur in the demersal waters over the Continental Shelf from the Gulf of Maine to Cape Hatteras, North Carolina. Juvenile and adult black seas bass are found in the estuaries in the summer and spring in water warmer than 43° F (6° C) with salinities greater than 18 ppt, but winter offshore from south of New York to North Carolina (Steimle et al., 1999a). Black sea bass eggs are pelagic. Berrien and Sibunka (1999) as cited in NOAA TM 200, 2007 showed that in the Mid-Atlantic Bight, areas with high average egg densities were generally located on the continental shelf in the vicinity of large estuaries including Chesapeake Bay, the Delaware River, and the Hudson River. Eggs are collected off Cape Hatteras as early as January but these may be reproductive products transported by the Gulf Stream from spawning areas to the south (Mercer 1978, as cited in NOAA TM 200, 2007).

The NMFS has designated the Hudson River mixing and salinity zones as EFH for black sea bass juveniles and adults. It is unlikely that this species occur in the project area due to the low salinities.

5.5 Bluefish

Bluefish (*Pomatomus saltatrix*) are common inshore inhabitants of the New York Bight, arriving in May and usually departing by November. Two major spawning aggregations are in the mid-Atlantic – a spring spawning stock and a summer spawning stock. Most of the bluefish population in the New York Bight probably originates from the spring spawning stock. The spring spawners move into the waters where the Gulf Stream and the continental shelf waters meet between northern Florida and Cape Hatteras. Bluefish spawn as they migrate northward. North of Cape Hatteras, the adults move shoreward.

The smaller, post-spawned bluefish may spend summers in the Chesapeake and Delaware Bays and Albemarle Sound. Larger fish move north for a longer period than the smaller bluefish, and thus migrate farther. Some move into Long Island Sound and more northern areas. In autumn, bluefish migrate back to the wintering areas off south Florida and the South Atlantic Ocean.

Bluefish eggs are buoyant and pelagic and hatch in about two days. The newly hatched larvae are also pelagic and remain in offshore waters for one to two months before migrating shoreward toward shallow-water nursery areas; for this reason, no early life-stages were collected in the study area during the utilities' studies. Young-of-the-year (YOY) bluefish typically first enter areas north of the George Washington Bridge in early June and remain there until at least early October. They are most common in shallow, more saline areas of the estuary, but can range as far upriver as the Cornwall region. Salinity intrusions into the estuary appear to be a major determinant of geographic distribution within the estuary. YOY bluefish are also abundant in areas of the estuary south of the George Washington Bridge and adjacent waterways, which are part of the larger, coastal distribution (ASA, 2006).

Seasonal migrations of bluefish represent an important recreational and commercial fishery during the summer months along the northeastern shores of the US. Although spawning offshore during summer, juveniles move in large numbers into the warmer inshore waters of the bay. These fish are voracious feeders, consuming a wide variety of fish and invertebrates in the water column. Mackerels, menhadens, alewives, herrings, and weakfish, as well as shrimp, lobsters, squid (*Loligo opalescens*), crabs, mysids, and annelid worms, are all part of the bluefish's diet. The abundance of juveniles in shallow nearshore waters also provides an important source of prey for other predatory species. The NMFS has designated the Hudson River mixing and salinity zones as EFH for bluefish juveniles and adults. Except for brief

periods in the summer when salinities are higher, it is unlikely that this species occur in the project area due to the low salinities.

5.6 Cobia

The cobia (*Rachycentron canadum*) is a fast-swimming fish that can be found near shore or inshore inhabiting inlets, bays, and mangrove swamps and is often seen around buoys, pilings, and wrecks. Cobia are distributed from Massachusetts to Argentina. Cobia primarily feed on crabs, squid, and small fish and can reach a size of up to 6 feet and 331 pounds (lbs), although they more commonly reach a size of between 22 and 110 lbs (Robins et al., 1986). The NMFS has designated the Hudson River as EFH for cobia eggs, larvae, juveniles, and adults. However, due to low salinities in the project area, it is unlikely that the species would often be present near the project.

5.7 King Mackerel

The king mackerel (*Scomberomorus cavalla*) is a fast-swimming fish that roams in schools. Their distribution ranges along the western coast of the Atlantic Ocean from North Carolina to Massachusetts and also in the Gulf of Mexico (Beaumariage, 1973). They prefer warm waters and are found along reefs and in coastal waters. Peak spawning occurs from May to early July and in late July to early August. King mackerel primarily feed on other fish and reach a size of up to 5.6 feet and 99.2 pounds (NMFS, 2017).

King mackerel are a "coastal pelagic" species, meaning they live in the open waters near the coast. They are typically found at depths of 115 to 591 feet (NMFS, 2011); although, they are sometimes found close to shore. King mackerel are voracious feeders that may be seen leaping out of water in pursuit of prey. Juvenile king mackerel prey on larval fish; adults prey on fish, squid, and shrimp and reach a size of up to 66 in and 220 lbs (NMFS, 2011).

King mackerel migrate to the northern part of their range in the summer and to the southern part in the winter. Migrations are based on water temperature and availability of food. King mackerel also form large schools. King mackerel span from May through October on the Outer Continental Shelf (NMFS, 2011). The NMFS has designated the Hudson River as EFH for king mackerel eggs, larvae, juveniles, and adults. Due the low salinities in the project area, it is unlikely this species utilizes the project area.

5.8 Red Hake

Red Hake (*Urophycis chuss*) are distributed from the Gulf of St. Lawrence to North Carolina, but are most abundant between Georges Bank and New Jersey. Red hake undergo extensive seasonal migrations, moving into shallow waters to spawn in spring and summer and offshore to deep waters in the winter. Spawning occurs from May through November. The eggs are buoyant (Geiser, 1984) and are generally found in water temperatures below 50°F (10°C).

The first months of a red hake's life are spent drifting at or near the surface, and fry of 0.5 to 4 in have been observed in summer under floating eelgrass or rockweed. Juvenile red hake are often found near benthic habitats with abundant shell fragments, including areas with abundant sea scallops (NEFMC EFH, 1998). Adult red hake are often found in water temperatures below 54°F at depths of between 33 and 98 feet with a salinity range of 33 to 34 ppt (NEFMC EFH, 1998). The red hake's diet consists

primarily of shrimp, squid, bergalls, small eels, spearing, sand eels, and the young of other species (Geiser, 1984).

The NMFS has designated the Hudson River mixing and salinity zone as EFH for red hake larvae, juveniles, and adults. Due the low salinities in the project area, it is unlikely this species utilizes the project area.

5.9 Scup

Scup (*Stenotomus chrysops*) occur primarily in the Mid-Atlantic Bight from Cape Cod to Cape Hatteras. The scup population in the Middle Atlantic Bight spawns along the inner continental shelf off southern New England from May through August with a peak in June to July. Larvae occur in coastal waters during the warmer seasons, feed upon small zooplankton, and are prey to a variety of planktivores, including medusae, crustaceans and fish. Larvae settle to the seafloor in coastal and estuarine waters when they are about 25 mm in length, but this event is poorly documented. During the summer and early fall, juveniles and adults are common in most larger estuaries and coastal areas in open and structured habitats where they feed on a variety of small benthic invertebrates (NOAA TM 149, 1999).

The life history of scup is typical of most demersal fishes, with pelagic eggs and larvae, and a gradual transition to the demersal adult stage. As a temperate species, scup is at the northern limits of its range in the northeastern United States and migrates seasonally during spring and autumn. In summer, scup are common in inshore waters from Massachusetts to Virginia, while in winter, scup are found in offshore waters between Hudson Canyon and Cape Hatteras. Spawning occurs during summer months (Steimle et al., 1999c).

In 1999, the NOAA Technical Memo for the species indicated that commercial landings of scup in the Middle Atlantic Bight have declined substantially since peak landings in the 1950s and early 1960s; although there was a minor peak in landings in the early 1980s. The Middle Atlantic Bight stock is currently considered overfished because the stock is near record low abundance levels (NMFS TM 149, 1999). The NMFS has designated the Hudson River as EFH for scup eggs, larvae, juveniles, and adults. Except for brief periods of time in the summer when salinities are higher, it is unlikely this species utilizes the project area.

5.10 Spanish Mackerel

The Spanish mackerel (*Scomberomorus maculatus*) is a fast-swimming fish that roams in large schools. Spanish mackerel can be found near shore congregating around channels and bays, and are distributed from Cape Cod to South Florida, although they are rarely found north of the Chesapeake Bay (Robbins et al., 1986). Spawning occurs from July to August and as late as September. Larvae can be found within inshore waters at temperatures of about 68 to 86 degrees F. Juveniles prefer estuarine and coastal waters. Adult habitat ranges from tidal estuaries to open water and adults prefer water temperatures of 69.8 to 80.6 degrees F (ASMFC, 2016). Spanish mackerel primarily feed on shrimp, squid, and small fish and reach a size of up to 37 in and 24 lbs. The NMFS has designated the Hudson River as EFH for Spanish mackerel eggs, larvae, juveniles, and adults. However, due to low salinities in the project area, it is unlikely that the species would often be present near the project.

5.11 Summer Flounder

Summer flounder (*Paralichthys dentatus*) or fluke, occur from the southern Gulf of Maine to South Carolina. Summer flounder are concentrated in bays and estuaries from late spring through early autumn, when an offshore migration to the outer continental shelf is undertaken. On the outer shelf they are found at depths of up to 148 feet. Many summer flounder come close inshore when the waters are warm, but the great majority of the population, especially larger fish, lies farther offshore at that time of year (Bigelow and Schroeder, 1953). Adult and juvenile summer flounder normally inhabit shallow coastal and estuarine waters during the warmer months of the year and remain offshore during the fall and winter (NOAA TM 151, 1999).

Summer flounder spawn during the fall and winter while the fish are moving offshore or onto their wintering grounds; the offshore migration is presumably keyed to declining water temperature and decreasing photoperiod during the autumn. Larvae are transported toward coastal areas by prevailing water currents.

Development of post-larvae and juveniles occurs primarily within bays and estuarine areas. Summer flounder often bury themselves in the soft bottom of the ocean or river. They consume small fish, most notably small mossbunker, squid, mackerel, sea robins, sand eels, killifish, and spearing. NMFS has designated the Hudson River mixing and salinity zones as EFH for summer flounder larvae, juveniles, and adults. Due to the low salinities in the project area, it is unlikely this species utilizes the project area.

5.12 Winter Flounder

Winter flounder (*Pleuronectes americanus*) are distributed in the northwest Atlantic from Labrador to Georgia. The species is found in brackish and salt water habitats. Abundance is highest from the Gulf of St. Lawrence to Chesapeake Bay. Optimum substrate for adults and juveniles is silty sand. The diet consists primarily of benthic invertebrates. Movement patterns are generally localized. Winter flounder undertake small-scale migrations into estuaries, embayments, and saltwater ponds in winter to spawn, subsequently moving to deeper water during summer. Winter flounder tend to return to the same spawning locations in consecutive years. Optimum water temperature for spawning is 34° to 39.2° F. Females usually produce between 500,000 to 1.5 million eggs. Eggs are adhesive and settle to the bottom (New England Fishery Management Council, 1998).

Generally, winter flounder release their eggs within areas that are less than 50°F, with salinities from 10 to 30 ppt, and in depths of less than 15 feet. Larval winter flounder are often found in shallow water at depths of less than 18 feet (6 m) (NEMFC EFH, 1998). Juvenile and adult flounder can be found in waters of 163 and 328 feet in depth, respectively. The NMFS has designated the Hudson River as EFH for winter flounder eggs, larvae, juveniles, adults, and spawning adults. Due to the low salinities and deep depths of the project area, winter flounder would not use the project area as a spawning resource.

5.13 Windowpane Flounder

Windowpane flounder (*Scophthalmus aquosus*), also known as sand flounder, are distributed on the northwest Atlantic continental shelf from the Gulf of St. Lawrence to Florida. This species inhabits large estuaries and is a shoal water benthic species that prefers sandy bottoms, as its name implies. However, it

also frequents softer and muddier grounds (Bigelow and Schroeder, 1953). Windowpane is not a target of the commercial fishing industry, but is mainly caught as bycatch in bottom trawl fisheries (NOAA TM 137, 1999).

Peak spawning activity occurs in Mid-Atlantic Bight waters (which extend from Montauk, NY to the Virginia/North Carolina border), in May and October. The eggs of the windowpane flounder are spherical and buoyant. Stomach content data collected during Northeast Fisheries Science Center (NEFSC) bottom trawl surveys indicate windowpane feed on small crustaceans (e.g., mysids and decapod shrimp) and various fish larvae including hakes and tomcod, as well as their own species (NOAA TM 137, 1999). The NMFS has designated the Hudson River as EFH for winter flounder eggs, larvae, juveniles, adults, and spawning adults. Due the low salinities in the project area, it is unlikely this species utilizes the project area.

6. Impact Analysis

Impacts from sediment resuspension due to dredging activities have the potential to occur. Based on the project duration (approximately 4 months for dredge activity), the relatively small dredging and capping areas (approximately 7.6 and 2.5 acres, respectively) compared to the overall size of the habitat, and the implementation of best management practices (BMPs) and engineering controls (discussed in Section 8), the impacts to species utilizing available EFH are expected to be minimal.

6.1 Water Column Habitat

The increase of resuspended sediments would generally be minimal and well within the normal background levels of the area, with the exception a few areas of higher concentrations in the immediate vicinity of the dredge. The resuspended materials would not affect water quality and would result in localized negligible increases. Moreover, these areas of higher concentration would represent a minute fraction of the available water column within the river.

6.2 Benthic Habitat and Invertebrates

A wide array of benthic fauna occurs in the Hudson River. The aquatic fauna vary from motile and sessile benthic organisms to resident and early life stages of numerous fish species. These organisms could be impacted by sediment resuspension that may interfere with their methods of feeding (i.e., filter feeders) and/or impair their habitat due to an increase in suspended sediments or burial through deposited sediments.

Habitats can vary from densely submerged aquatic vegetated beds to habitats with high rugosity environments (e.g., reefs, large boulders, etc.) to relatively flat, featureless sediment-dominated habitats. Although devoid of vegetation or lacking dramatic topographical variability, benthic sediments provide valuable habitat for numerous benthic invertebrates (e.g., worms, clams, etc.). Moreover, these interstitial organisms serve as prey species for fish, crabs, and other fauna.

Benthic sediments can range from soft, fine-grained clays to coarse-grained sands. In close proximity to the dredging activity, TSS concentrations would increase for the short term, but impacts would be negligible in the surrounding area. Any upstream and downstream transport would be localized and would be below levels that would affect normal life functions of benthic invertebrates. Thus, impacts to benthic habitat due to TSS would be minimal, if any.

Approximately 7.6 acres of sediment dredging area is targeted for removal and backfill that could potentially impact benthic habitat/food sources for during the construction period of October to February. Although some habitat disruption will occur during this timeframe, the long-term benefit will be gained by reducing areas of sediments known to contain potentially ecologically-threatening constituents. It is anticipated that restoration of the dredged areas with clean backfill materials, along with natural sedimentation processes will allow for the re-colonization of native benthic communities. Similarly, natural sedimentation will occur on the cap, which will also allow for the re-colonization of native benthic communities. The re-colonization of the benthic community within the dredge area substrates will provide benthic habitat and food sources.

To further minimize the potential impacts of the remediation activities, as discussed below in Section 8, the dredging will occur during times of the year when bottom feeders are unlikely to be present in the dredging area. In addition, the dredge area (approximately 7.6 acres) and capping area (approximately 2.5 acres) is relatively small (less than 1%) as compared to the overall sediment surface within the Hudson River that provides benthic habitat.

6.3 Submerged Aquatic Vegetation and Significant Coastal Fish and Wildlife Habitats

6.3.1 Submerged Aquatic Vegetation

No submerged aquatic vegetation (SAV) beds have been observed to occur along the shoreline of the dredge prisms. Moreover, much of the dredge area is below 40 feet in depth, where SAV would not occur due to light attenuation. It is expected that little, if any, impact would occur to SAV beds due to sediment suspension or deposition.

6.3.2 Significant Coastal Fish and Wildlife Habitats

The Kingston-Poughkeepsie Deepwater habitat has been designated as a SCFWH by the NYSDEC. Any activity that would substantially degrade water quality, increase turbidity or sedimentation, alter flows, salinity, or temperature, reduce water depths, or degrade or alter benthic communities in Kingston-Poughkeepsie Deepwater would result in significant impairment of the habitat (NYSDEC, 2012). Any physical alteration of the habitat through dredging or filling would result in a direct loss of valuable habitat. Such activities could have significant impacts on striped bass and sturgeon populations during spawning, and incubation periods (May-July, primarily) and overwintering times. Habitat disturbances would be most detrimental during fish spawning and nursery periods, which generally extend from April through August for most warm water species.

Dredging activities within the SCFWH area are limited to approximately 25,000 CYs within approximately 4 acres. Turbidity beyond the dredging area will be controlled by using an environmental bucket within a containment cell which will be outfitted with turbidity curtains that extend to the river bottom and floating booms on all sides. In addition, because dredging activities are anticipated to be conducted between October and February and less intrusive capping activities between July and September, any disturbances to habitat that would occur due to sedimentation will be short term and minor. Moreover, the removal of sediments known to contain potentially ecologically-threatening constituents would provide long-term benefits to the fauna of the deepwater habitat which transit through the Hudson River.

6.4 Fish

Fish populations in the Hudson River are dynamic and change with the seasons. Several species of fish are present year round; however, many species only occur during the warmer months of the year or during migration periods in the spring and fall.

Resuspension of estuarine sediments have variable impacts on fish depending on species and life stage. Lethal levels of water column solids vary widely among species; one study found that the tolerance of adult fish for suspended sediment ranged from 580 milligrams per liter (mg/L) to 24,500 mg/L (Shrek et al. 1975 as cited in NMFS, 2003). Common impacts to fish are the abrasion of gill membranes (resulting in inability to collect oxygen), impairment of feeding, reduction in dissolved oxygen, and fatal impacts to early life stages. Increased TSS can inhibit migratory movements as well. A study conducted in 1976 determined that TSS concentrations as low as 350 mg/L blocked upstream migrations (NOAA 2001).

Larval stage fish also have a wide suspended sediment tolerance ranges; however, the reported data is generally thought to represent tolerance levels for only relatively short exposure periods (e.g., <24 hours) (Morgan and Levings, 1989). Beyond that timeframe, mortality can occur at concentrations as low as 1,300 mg/L (Morgan et al., 1983). Kiorboe et al. 1981, (as cited in Clarke and Wilber, 2000) indicates that hatching of striped bass and white perch can be delayed if daily sediment concentrations reach 100 mg/L. Wilbur and Clarke 2001 (as cited in NMFS, 2003), indicate that hatching is delayed for striped bass and white perch at concentrations of 800 and 100 mg/L, respectively.

When sediments are resuspended they disperse throughout the water column and also settle to the bed of the waterway within which construction is occurring. Impacts from deposited sediments can pose significant threats to aquatic organisms. For fish species, burial of eggs can result in mortality. Sediment deposition may have negative short-term impacts to adult and juvenile fish due to benthic habitat alterations and as a result of reduced foraging opportunities.

Fish species may be present within the dredging area during certain times of the year. Possible effects of the sediment dredging and capping on these species and their associated habitats include modified fish migration and feeding habits, as well as loss of eggs/larvae, habitat and/or food sources. However, the losses to the fish population are anticipated to be minimal. The presence of the turbidity curtain around the impacted sediments dredge areas, during the migration periods, may cause disturbances to fish for movement within the system.

Because the turbidity curtain installation and removal activities and dredging is anticipated to require approximately four months to complete, any effects on fish migration and feeding habits are anticipated to be temporary. Also, any juvenile or adult fish present within the remediation area are anticipated to be mobile and would likely avoid the dredge area during the turbidity curtain installation and removal, dredging and cap installation activities. Furthermore, the curtains will keep fish from entering the dredge areas during the remediation. Finally, as further discussed below in Section 8, BMPs and engineering controls, including conducting work when certain fish species are less likely to be present within the remediation area, will be implemented to minimize the potential for the dredging and capping activities to adversely affect fish migration and feeding habits.

Loss of eggs/larvae, habitat, and/or food sources may result from installation and securing of turbidity curtain anchoring devices placed around the dredge areas and during dredging activities. A small targeted area will be closed at a time and the turbidity curtain will be moved to the next dredge location as the sediment removal activities progress. Approximately 7.6 acres of sediment dredging area is targeted for removal, and backfill that could potentially impact fish eggs/larvae for approximately during the construction period of October to February. In addition, two areas above the underwater utility crossings

are targeted for capping (approximately one acre), and the side slope along the river will be graded and capped for stabilization (approximately 2.5 acres).

Due to the use of silt curtains and other BMPs, the water depths, and normal current speeds, it is anticipated that the TSS levels that would occur as a result of dredging operations will be considerably below the physiological thresholds of adult fish; moreover, dredging TSS levels are anticipated to be well below concentrations that would impact migration. Thus, it is anticipated that dredging during the timeframe (October through February) would be the least impactful to the river's ecological resources.

6.5 Essential Fish Habitat

It is anticipated the proposed project would have minimal, if any, effect on EFH or EFH species due to the temporary period of time when dredging would be conducted (anticipated from October 2018 through February 2019) and the small area that would be dredged (7.6 acres) and capped with mats (2.5 acres). Moreover, the proposed dredging would not occur during the key migratory spawning season (March 1 through June 30) and appropriate sediment containment devices (e.g., containment cells) would be employed to limit disturbance to adjacent aquatic environments during dredging and further reduce any potential impacts to EFH or EFH-managed species. Water quality (turbidity) will be monitored for the duration of the dredging by means of three buoy-mounted remote sensing stations that will be moored around the perimeter of the work area to confirm that the containment cell is functioning properly.

During construction, dredging, capping, and vessel activity may cause some fish resources to temporarily relocate from the project area with the result of decreased fish biomass in the project area. Many of the listed EFH species prefer saline environments and thus, due to the low salinities, it is likely that many of the EFH species listed would occur infrequently, if at all in the project area, or may be present in limited numbers during the warmer months of the year.

A benthic habitat comprised of finer-grained sediments is somewhat common in the Hudson River. The placement of clean sand and removal of the toxins associated with NAPL would have long-term benefits to the marine community. The placement of concrete mattresses and other hard surfaces would also result in topographic relief to the project area and provide a substrate for sessile organisms to colonize.

As such, disturbance to the habitat and benthic invertebrates would not result in significant impacts to EFH prey species' populations. Also, the waters of the Hudson River provide habitat to small baitfish, which some of the EFH species may feed upon. It is anticipated that any loss of baitfish individuals would be minimal and not jeopardize their regional populations, which would continue to be preyed upon by EFH species.

7. Endangered Species Concerns

Pursuant to Section 7 of the Endangered Species Act of 1973 (as amended), a request for project review was sent on November 10, 2017 to NOAA's NMFS Greater Atlantic Region Office. A subsequent response letter was received from the NOAA on November 16, 2017. Since endangered species (Atlantic sturgeons and shortnose sturgeons) are identified to be present near the work area, NOAA recommended considering using timing restriction for in-water work and use of best management practices to reduce effect for suspended sediments. Their comments are incorporated into the final design by limiting the dredge work window to October to February for dredge work and by designing a turbidity curtain that will reach all the way to the bottom of the dredge areas to minimize turbidity outside of the work area.

Additionally, a letter was sent to the USFWS New York Field Office. The subsequent response letter dated November 7, 2017 referenced their website listings for determining the species known to occur within the vicinity of the site. The letter mentioned the protection of bald eagles and guidance to minimize impact to the migratory bird species. Since work will be on and in the water, there will minimal impacts to surrounding areas that may be used by these birds. The letter also identified Indiana Bat (*Myotis sodalist*) (endangered species), Northern Long-eared Bat (*Myotis septentrionalis*) (threatened species) and Dwarf Wedgemussel (*Alasmidonta heterodon*) clams (endangered species) in the official species list. Because the project work will be done on the water, minimal impact to mammals is expected. An AECOM ecologist visited the site on December 11, 2017 to evaluate if there are any trees at the site that may be an important bat habitat. The clams and mussels identified in the list are typically found in freshwater streams, and not necessarily tidal portions of the Hudson River. Moreover, these species were not observed during the benthic sampling that occurred on site during December 2017. No critical habitats were identified in the project area under the jurisdiction of USFWS. The USFWS letter also identified the Atlantic sturgeon (*Acipenser oxyrinchus*) and shortnose sturgeon (*Acipenser brevirostrum*) (both endangered); impacts to these species are described above, in relation to oversight by NOAA.

Lastly, a letter was sent on November 10, 2017 to the NYSDEC New York Natural Heritage Program, part of the Division of Fish, Wildlife & Marine Resources. The subsequent response letter dated November 21, 2017 referenced the endangered shortnose sturgeon (*Acipenser brevirostrum*) and protected Atlantic sturgeon (*Acipenser oxyrinchus*) within the Hudson River, and nesting peregrine falcons (*falco peregrinus*) within a half-mile of the site. However, the project will be conducted on and in the water and will not affect the surrounding land areas and bridges nearby, where peregrine falcons might be nesting.

Based on the available habitat within the remediation area in comparison to the habitat requirements of the listed species, it is anticipated that the Atlantic and shortnose sturgeon will likely utilize this habitat during a portion of their lifespan. Shortnose sturgeon have been documented in the Hudson River from the New York Harbor to the Troy Dam. From late fall to early spring, adult shortnose sturgeon concentrate in a few overwintering areas. Spawning adults concentrate just north of Kingston (RM 94) and non-spawning adults concentrate near Kingston and Haverstraw Bay. When water temperatures reach 8° C, typically in mid-April, reproductively active adults begin their migration upstream to the spawning grounds that extend from Troy to Coxsackie (RMs 149 to 118). Spawning typically occurs until water temperatures reach 15° C (generally from late April through May), after which adults disperse quickly downriver into their summer range. The broad summer range occupied by adult shortnose sturgeon

extends from approximately RM 24 to RM 110. Similar to non-spawning adults, most juveniles are distributed throughout the mid-river regions during the summer from approximately RM 24 to RM 91 and move back into the Haverstraw Bay region during the late fall. Recent information suggests that shortnose sturgeon are using the Lower Hudson River below RM 9, at least during the November to April time frame (NOAA 2008b).

Based on the shortnose and Atlantic sturgeon life cycles, with regard to spawning habitat and overwintering areas, it was concluded that the BMP would be to limit the dredge work window, install the turbidity curtain around the active dredge work area, and backfill the dredge area with clean sand during the timeframe when these species are less likely to be present in the site area (October through February), to avoid the overwintering near Kingston and the migration to the spawning grounds in conformance with the guidance received from the NOAA NMFS. The less intrusive capping over the utility crossings and side slope is proposed between July 2019 and September 2019, after the published key migratory spawning season (March 1 through June 30)

Given the size of the remediation area relative to the overall habitat (less than 1%) and timing of the proposed activities, potential disruption to the shortnose and Atlantic sturgeon appears to be insignificant.

8. Mitigation Activities

To minimize impacts to Hudson River during the implementation of the remedial activities, land-based and water-based BMPs will be implemented prior to the start of work. The BMPs are typical of the types of controls successfully used at other environmental remediation projects to minimize impacts to riverine systems. BMPs and engineering controls, including the containment cell, will be installed prior to the start of dredging activities and will be used throughout these activities accordingly. Additionally, dredged areas will be backfilled with clean sand imported from upland sources and transported to the site via barge. Dredged material will be dewatered at the site and shipped off-site for treatment and disposal.

8.1 Land-based Controls

Land-based erosion and sedimentation BMPs include the placement of staked straw bales and/or silt fences along the river bank and around disturbed areas; construction of stabilized construction entrances; and implementation of stormwater inlet protection (i.e., straw bales placed around stormwater inlets). The BMPs will be installed during site preparation activities and will be completed prior to any land disturbance or clearing activities as may be required for installation of the bulkhead replacement. Initial measures will be set up on the perimeter of the project site. Before material staging areas or temporary access roads are constructed, appropriate erosion and sedimentation control measures will be implemented around these areas. These BMPs will reduce erosion to the river, thereby reducing turbidity and oxygen demands, and protecting against siltation.

A site-specific Erosion and Sedimentation Control Plan (ESCP) has been prepared in accordance with the New York State Standards and Specifications for Erosion and Sediment Control. In accordance with the ESCP, a NYSDEC-qualified inspector will monitor the erosion and sedimentation control measures to verify that the control measures are operating as intended and to identify any control measures in need of repair. The designated NYSDEC-qualified inspector will monitor all erosion and sedimentation control devices at least once every 7 calendar days and maintain inspection results on-site. The control measures will be maintained throughout the course of the site construction activities, and following the completion of the site construction activities until the site has been fully stabilized. Maintenance requirements may include repairs or modifications, as needed, based on site conditions and planned remediation activities.

8.2 Water-based Controls

Water-based control measures will include performing the dredging work within containment (i.e. turbidity curtain), and implementing surface water and water column monitoring activities. These BMPs will monitor, control and isolate potential sediment, NAPL and sheen releases to the river, thereby reducing turbidity and oxygen demands and protecting against siltation. The BMPs are comprehensive, state of the art, and include types of controls successfully used at other environmental remediation projects to minimize impacts to riverine systems such as the Hudson River. The various BMPs include:

- Environmental Bucket: Targeted river sediments will be dredged using an environmental bucket, which is designed to provide flat dredge cuts for maximum control of the dredged surface while also utilizing seals to limit loss of material as the bucket is raised through the water column.

- **Turbidity Curtains:** Prior to the dredging of NAPL-impacted sediments, a turbidity curtain will be installed around the perimeter of the dredge areas. Absorbent booms will be installed in sediment dredging areas to contain the migration of any NAPL sheens that may be encountered during sediment removal activities. The turbidity curtain system will be inspected and maintained through the duration of sediment dredging activities.
- **Work Area Surface Water Monitoring:** Visual surface water monitoring will occur throughout the dredging and backfilling operation. Oil absorbent booms and/or pads will be used around all platforms and turbidity curtains to prevent migration of sheens outside of dredge areas. If NAPL/sheens are observed outside the turbidity curtain, the sheen will be chased and absorbed using absorbent booms and/or pads. The primary controls (turbidity curtains) and sorbent booms next to the curtains will be inspected and repaired or replaced as necessary to ensure their effectiveness in capturing sediments and NAPL/sheens.
- **Downstream Surface Water Monitoring:** A patrol boat, equipped with oil absorbent and containment booms, will be available downstream of the work area to visually inspect the surface water and mitigate any sheens observed.
- **Turbidity Monitoring:** A turbidity monitoring program will be performed during the sediment removal and restoration activities. Water quality (turbidity) will be monitored for the duration of the dredging by means of three buoy-mounted remote sensing stations that will be moored around the perimeter of the work area to confirm that the containment cell is functioning properly. Turbidity will be measured at an upstream location, a location near the work zone, and a downstream location within Hudson River.
- **Inspections:** Inspections of the water-based controls will be conducted each day at the beginning of removal activities. Inspections will also be conducted, as appropriate, in response to visible sediment plumes migrating from the work area or measured turbidity levels above the action level of 50 nephelometric turbidity units (NTUs) above the turbidity level at the upstream monitoring location. Inspections in response to turbidity levels above the action level metric will begin with a surface inspection using a boat. If the cause of the turbidity exceedance cannot be determined through surface inspection (i.e., no visible damage, breach, tear, or dislocation), a hand-held turbidity meter or other appropriate method will be used to identify the source. The Construction Quality Assurance Plan (CQAP) will identify contingency measures to meet turbidity action levels. Contingency measures may include modification to dredge operations (e.g., fall height, cycle time, bucket handling procedures, use of a rinse tank, etc.) or modifications or repairs of the containment systems.
- **Timing:** If required by Federal and/or State agencies, the remediation will be implemented during Federal and State-issued work windows for the protection of fish and wildlife habitats. Based on current information regarding potential presence, habitat, and life cycles of Atlantic sturgeon and shortnose sturgeon within this section of the river, the dredging activities will be conducted during the October to February timeframe and the less intrusive capping activities will be conducted from July to September. Further refinement of this timeframe will be considered and incorporated into the final design. This timing should minimize the level of disturbance not only for the shortnose sturgeon, but also to other species that may utilize the surrounding area for potential spawning or overwintering habitat.

Due to these measures and the temporary nature of the project, it is not anticipated that the proposed project will have a long-term adverse effect upon the habitat. Implementation of the proposed dredging will assist in improving the water quality, sediment quality, and benthic habitat in the Hudson River.

9. References

Applied Science Associates (ASA), Inc. 2006. Year Class Report for the Hudson River estuary monitoring program. Prepared for Dynegy Roseton L.L.C., Entergy Nuclear Indian Point L.L.C., Entergy Nuclear Indian Point L.L.C., and Mirant Bowline L.L.C.

Cooper, J.C., F.R. Cantelmo, and C.E. Newton. 1988. Overview of the Hudson River Estuary. American Fisheries Society Monograph 4: 11-24.

Geiser, John, 1984. A Comprehensive Guide to Saltwater Fishing Along the Northeast Coast (The Shore Catch). The Asbury Park Press, Inc., Neptune, NJ.

Heimbuch. 2008. Potential Effects of Striped Bass Predation on Juvenile Fish in the Hudson River. Transactions of the American Fisheries Society 137:1591-1605.

Hudson River Environmental Conditions Observing System (HRECOS), 2017. Website accessed for Marist Pump Station information. <http://www.hrecos.org/>; accessed December 14, 2017.

National Marine Fisheries Service, 2003. Endangered Species Act Biological Opinion for the National Pollutant Discharge Permit of the Washington Aqueduct F/NER/2003/00600

NOAA, 2017. Website accessed to identify EFH species near the project area. (<https://www.greateratlantic.fisheries.noaa.gov/hcd/ny3.html>; accessed 6/8/2017)

NOAA, 2016. Tide Tables 2016 – East Coast of North and South America including Greenland. https://tidesandcurrents.noaa.gov/historic_tide_tables.html; Accessed December 2017.

NOAA Technical Memorandum NMFS-NE-137. Essential Fish Habitat Source Document: Windowpane, *Scophthalmus aquosus*, Life History and Habitat Characteristics. U. S. Department of Commerce. National Oceanic and Atmospheric Administration. National Marine Fisheries Service. Northeast Region. Northeast Fisheries Science Center. Woods Hole, Massachusetts. September 1999

NOAA Technical Memorandum NMFS-NE-149. Essential Fish Habitat Source Document: Scup, *Stenotomus chrysops*, Life History and Habitat Characteristics U. S. Department of Commerce. National Oceanic and Atmospheric Administration. National Marine Fisheries Service. Northeast Region. Northeast Fisheries Science Center. Woods Hole, Massachusetts. September 1999

NOAA Technical Memorandum NMFS-NE-151. Essential Fish Habitat Source Document: Summer Flounder, *Paralichthys dentatus*, Life History and Habitat Characteristics. U. S. Department of Commerce. National Oceanic and Atmospheric Administration. National Marine Fisheries Service. Northeast Region. Northeast Fisheries Science Center. Woods Hole, Massachusetts. September 1999

New York State Department of Environmental Conservation (NYSDEC), 2017. Website accessed for information on fish species in the Hudson River. (<http://www.dec.ny.gov/lands/97891.html>; accessed 11/15/17)

NYSDEC, 2005. Ecological Profile of the Hudson River National Estuarine Research Reserve. NYSDEC Contract No. C004646, December 2005.

New York State Department of State, Office of Planning and Development, 2012. Website accessed for information on Significant Coastal Fish & Wildlife Habitats.
<https://www.dos.ny.gov/opd/programs/consistency/scfwhabitats.html#HUDSON>; Accessed December 2017.

Pisces Conservation LTD. 2008. The Status of Fish Populations and the Ecology of the Hudson. Lymington, United Kingdom.

United States Fish and Wildlife Service (USFWS). 1997. *Significant Habitats and Habitat Complexes of the New York Bight Watershed*. Southern New England - New York Bight Coastal Ecosystem Program. Mid-Hudson River Estuary Complex #32. <http://nctc.fws.gov/resources/knowledge-resources/pubs5/begin.htm>; Accessed December 2017.

United States Geological Survey (USGS), 2017a. Internet site accessed for tide gage information at multiple sites as referenced in text. <http://waterdata.usgs.gov/nwis/rt>

USGS, 2017b. Website accessed for information regarding location of Hudson River Salt Wedge. https://ny.water.usgs.gov/projects/dialer_plots/hsfmis.html; accessed 11/13/2017. Wall, G.; Nystrom, E. & Simon, L. (2006), 'Use of an ADCP to Compute Suspended-Sediment Discharge in the Tidal Hudson River, New York'(Report 2006-5055), Technical report, U.S. Geological Survey.

APPENDIX A

Dredging Figures

File: P:\Jobs\Rem_Eng\Project Files\CHGE\900 CAD\910 CAD\20 SHEETS\PDF\Permitting 2\Permitting Figures.dwg Layout: VICINITY MAP User: erica.hart Plotted: Jan 11, 2018 - 10:06am Xref's:



AREA WITHIN
1 MILE RADIUS

PROJECT SITE

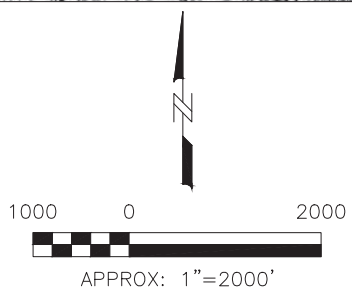

Map Source: U.S.G.S. 7.5' Quadrangle, Poughkeepsie, NY

For Agency Review Only



CENTRAL HUDSON GAS & ELECTRIC
HUDSON RIVER
DUTCHESS COUNTY, NY

VICINITY MAP
FORMER NORTH WATER STREET MGP
POUGHKEEPSIE

DATE: 1/11/18

FIGURE 1 OF 11

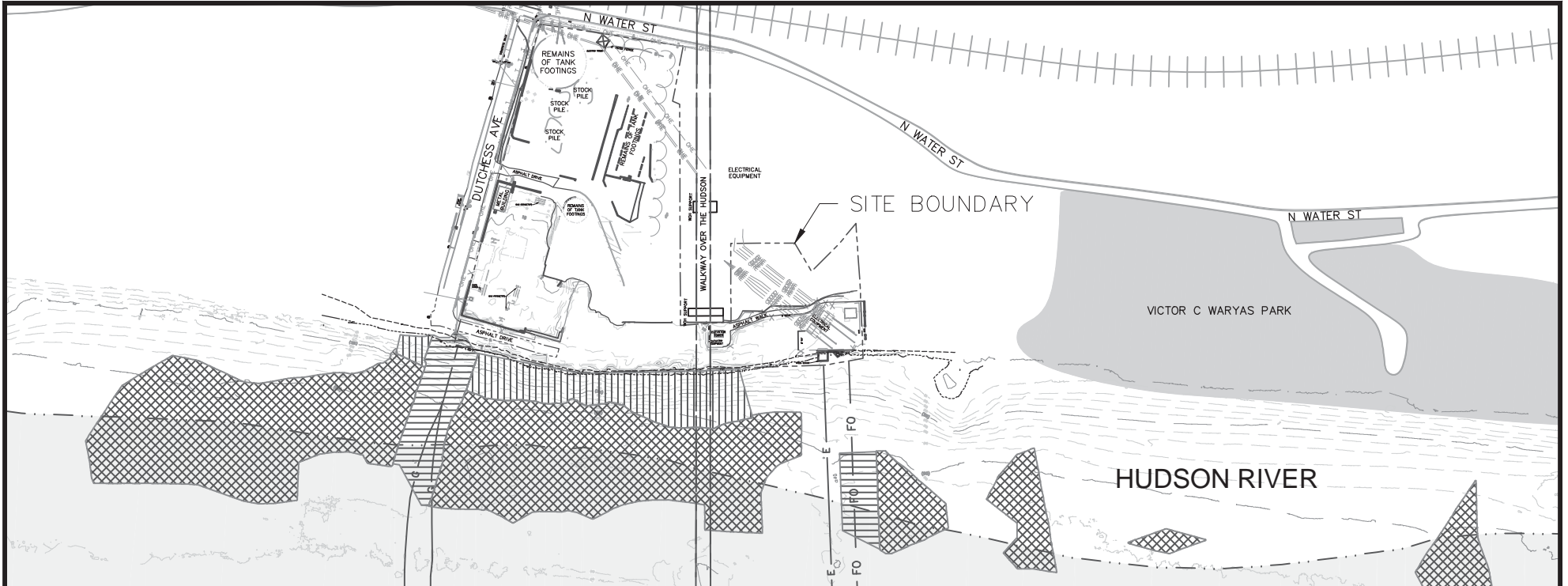

LEGEND

- | | | | |
|--|-------------------------|--|-----------------------------|
| | RAILWAY TRACKS | | |
| | GAS LINE | | |
| | ELECTRIC LINE | | |
| | FIBER OPTIC LINE | | PROPOSED SLOPE GRADING AREA |
| | OVERHEAD ELECTRIC LINE | | PROPOSED UTILITY CAP AREA |
| | EDGE OF WALKWAY | | DREDGE AREA |
| | SITE BOUNDARY | | |
| | EXISTING FENCE | | |
| | EDGE OF WOODS | | |
| | SCFWH AREA BOUNDARY | | |
| | MEAN HIGH WATER (1.93') | | |
| | MEAN LOW WATER (-1.58') | | |

KINGSTON-POUGHKEEPSIE DEEPWATER SCFWH AREA

For Agency Review Only

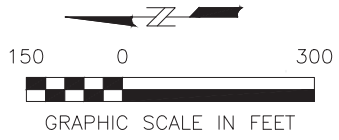

CENTRAL HUDSON GAS & ELECTRIC
HUDSON RIVER
DUTCHESS COUNTY, NY
DATE: 1/11/18

REMEDIAL ACTIVITIES PLAN
FORMER NORTH WATER STREET MGP
POUGHKEEPSIE, NY
FIGURE 3 OF 11

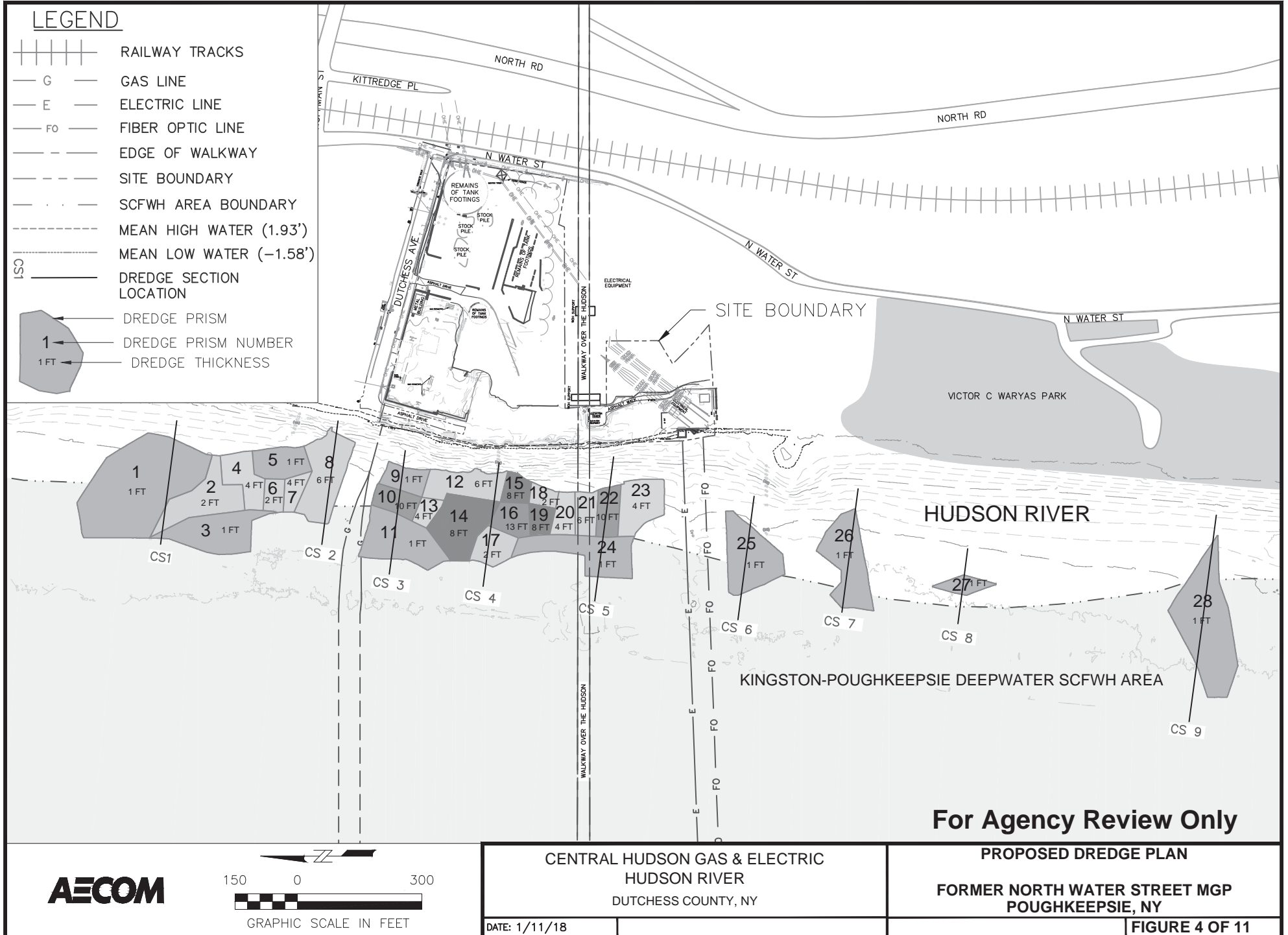

For Agency Review Only

DREDGE SECTION 2

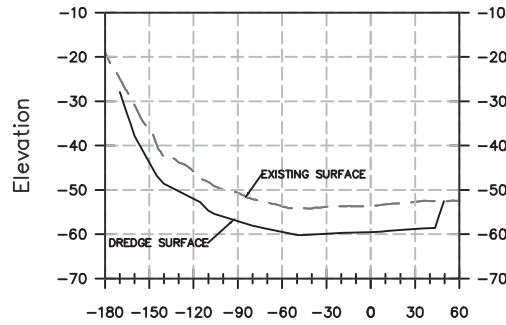
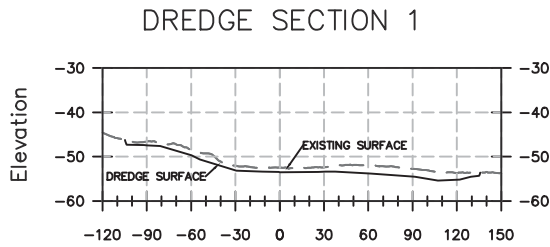

DREDGE SECTION 3

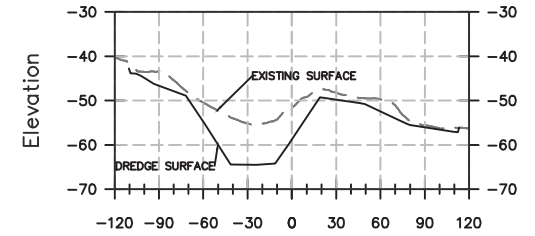

DREDGE SECTION 4

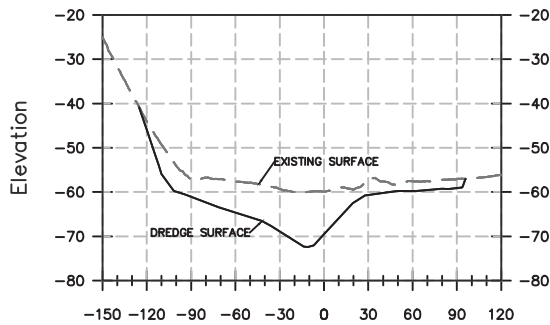

DREDGE SECTION 5

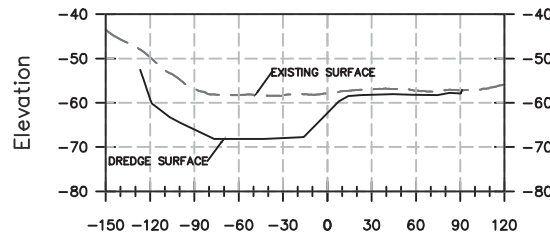

DREDGE SECTION 6

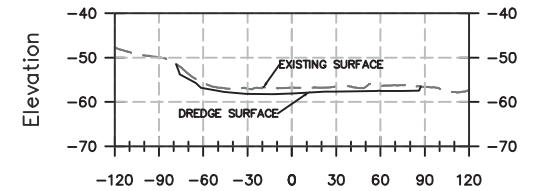

DREDGE SECTION 7

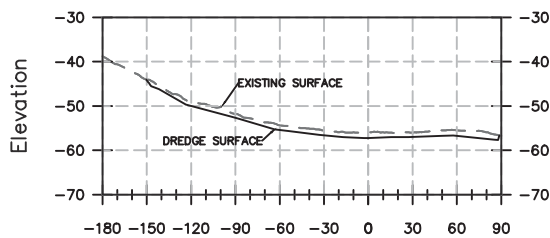

DREDGE SECTION 8

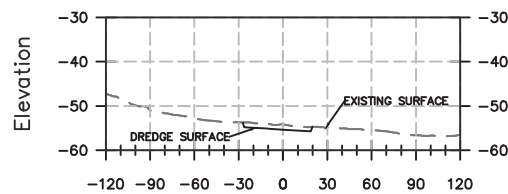

DREDGE SECTION 9

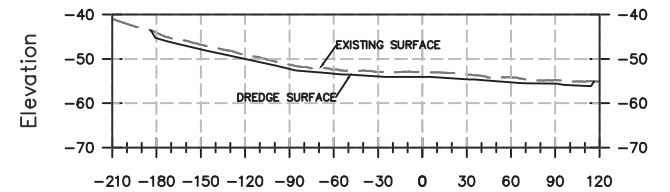

For Agency Review Only



CENTRAL HUDSON GAS & ELECTRIC
HUDSON RIVER
DUTCHESS COUNTY, NY

PROPOSED DREDGE PLAN
CROSS SECTIONS
FORMER NORTH WATER STREET MGP
POUGHKEEPSIE, NY

DATE: 1/11/18

FIGURE 5 OF 11

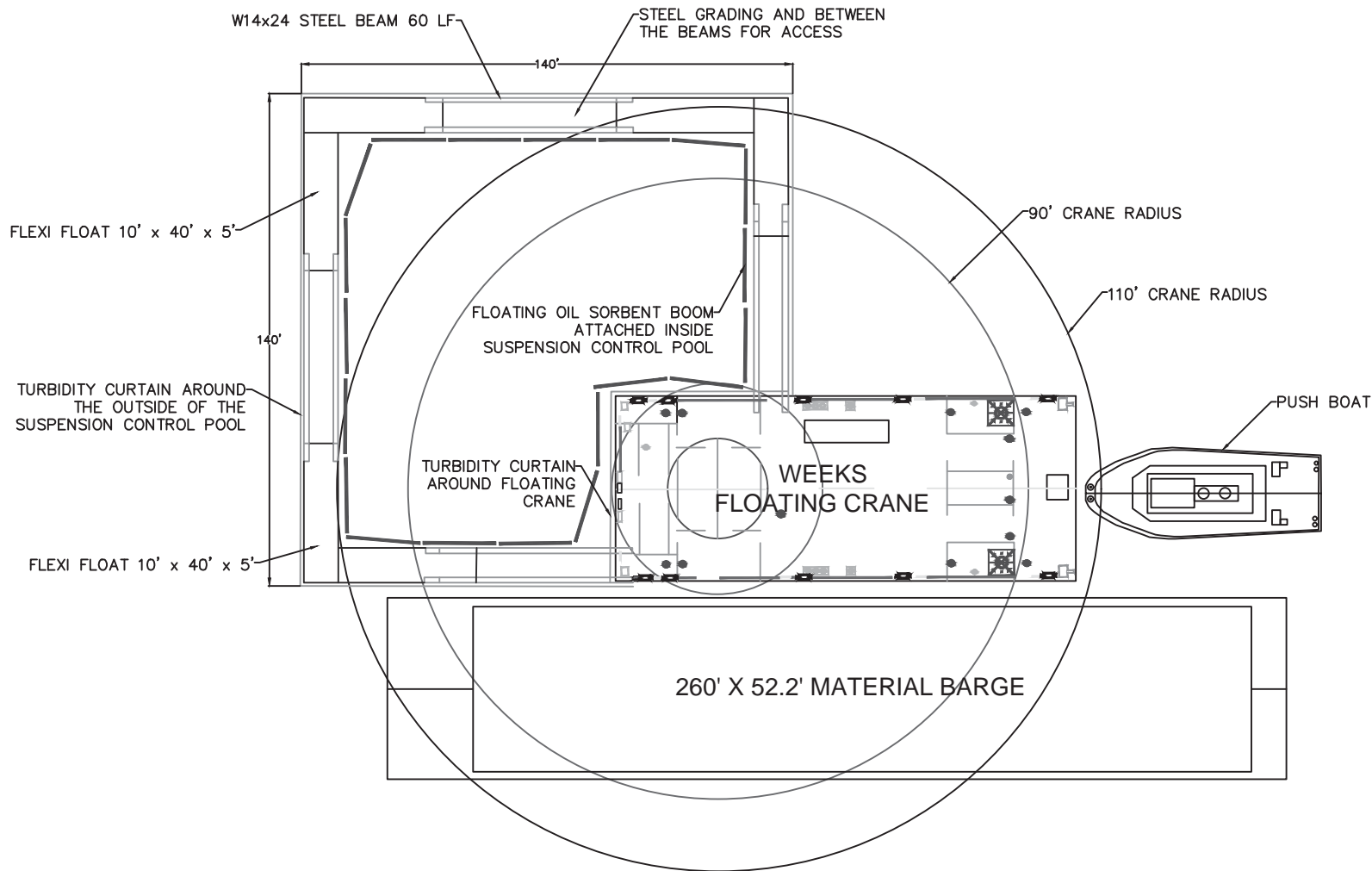

MOBILE SUSPENSION CONTROL SYSTEM SETUP OVERVIEW

NOTE: FIGURES NOT DRAWN TO SCALE. THESE ARE CONCEPTUAL DRAWINGS.

For Agency Review Only



CENTRAL HUDSON GAS & ELECTRIC
HUDSON RIVER
DUTCHESS COUNTY, NY

ENGINEERING CONTROLS
PLAN VIEW
FORMER NORTH WATER STREET MGP
POUGHKEEPSIE, NY

DATE: 1/11/18

FIGURE 6A OF 11

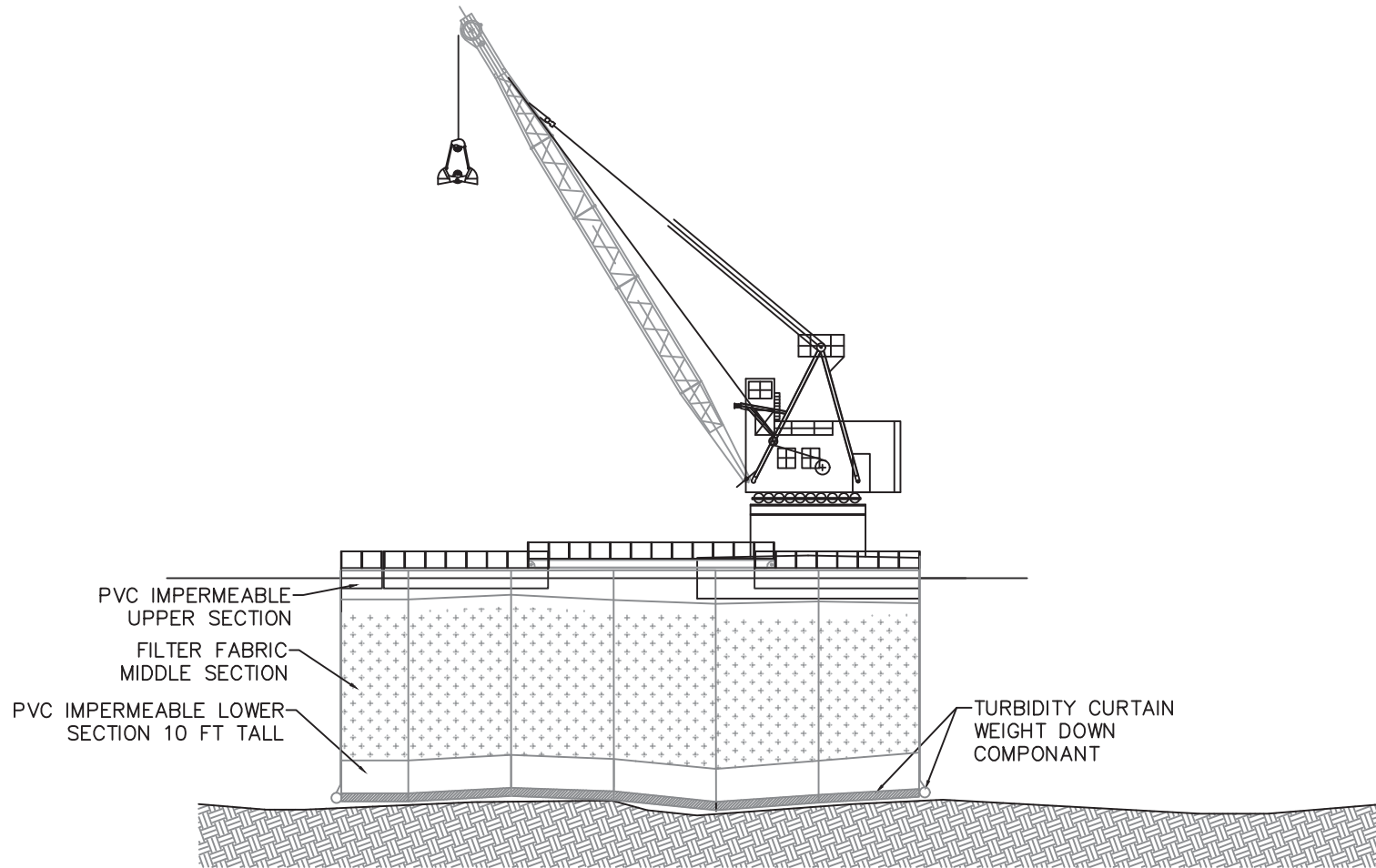

MOBILE SUSPENSION CONTROL SYSTEM SETUP
FRONT VIEW

NOTE: FIGURES NOT DRAWN TO SCALE. THESE ARE CONCEPTUAL DRAWINGS.

For Agency Review Only



CENTRAL HUDSON GAS & ELECTRIC
HUDSON RIVER
DUTCHESS COUNTY, NY

ENGINEERING CONTROLS
SIDE VIEW
FORMER NORTH WATER STREET MGP
POUGHKEEPSIE, NY

DATE: 1/11/18

FIGURE 6B OF 11

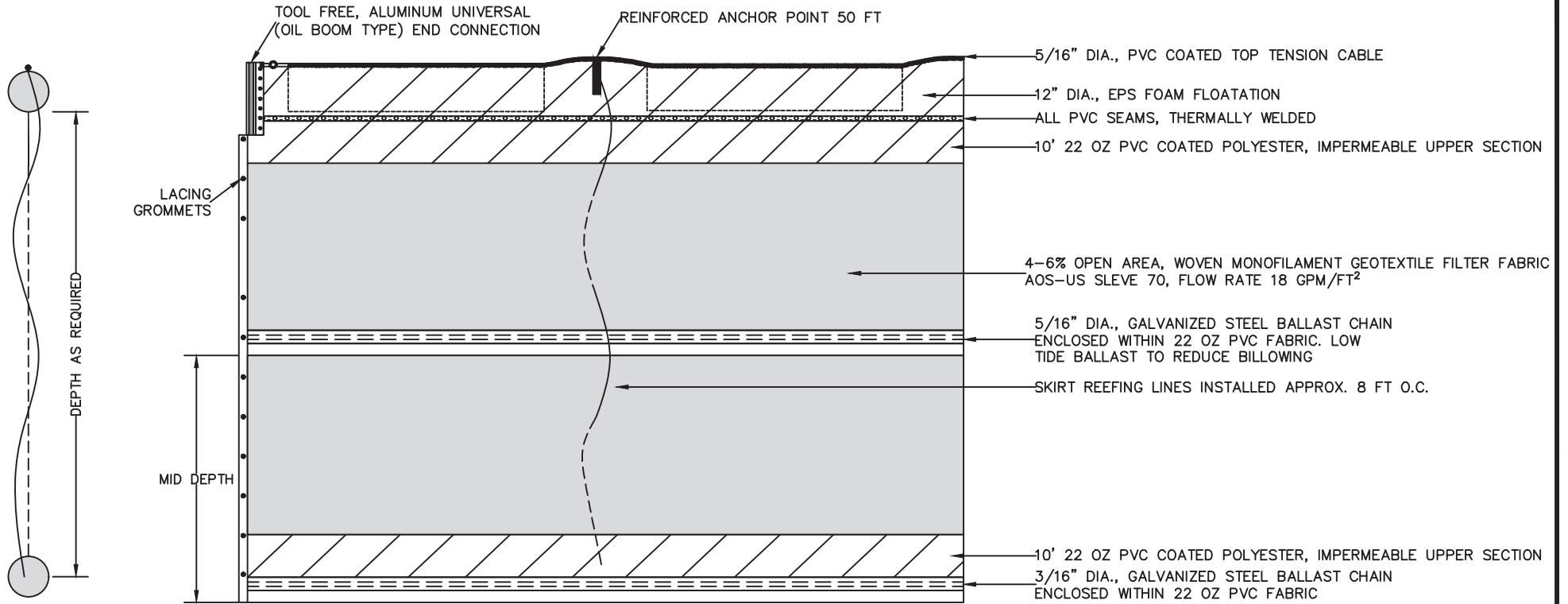

TURBIDITY BARRIER DETAIL

NOTE: FIGURES NOT DRAWN TO SCALE. THESE ARE CONCEPTUAL DRAWINGS.

For Agency Review Only



CENTRAL HUDSON GAS & ELECTRIC
HUDSON RIVER
DUTCHESS COUNTY, NY

ENGINEERING CONTROLS
DETAIL
FORMER NORTH WATER STREET MGP
POUGHKEEPSIE, NY

DATE: 1/11/18

FIGURE 6C OF 11

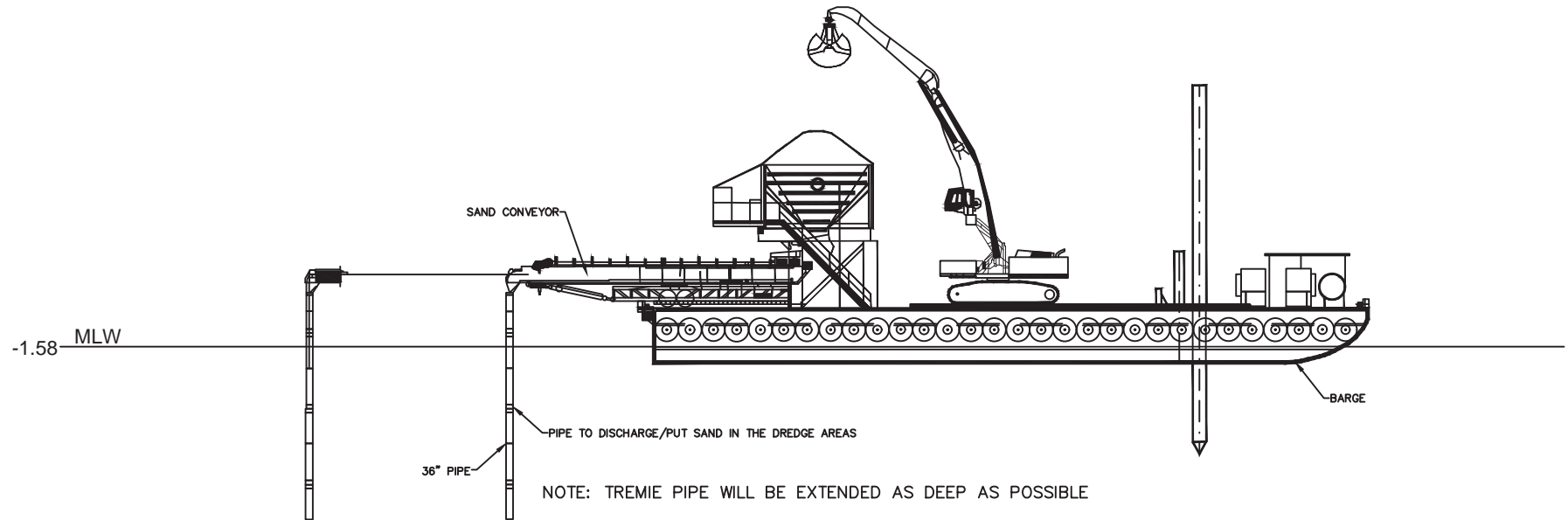

CONCEPTUAL DREDGE RESTORATION OPERATION

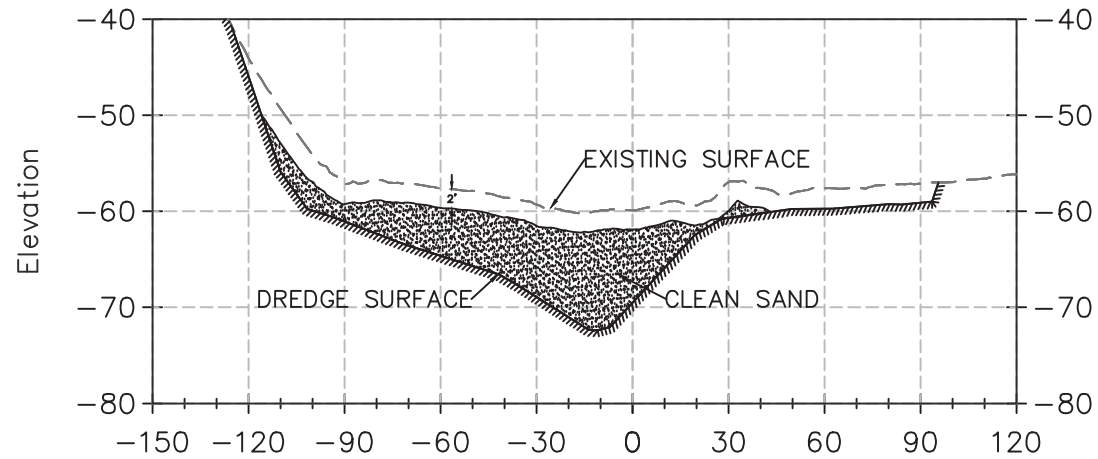

For Agency Review Only



CENTRAL HUDSON GAS & ELECTRIC
HUDSON RIVER
DUTCHESS COUNTY, NY







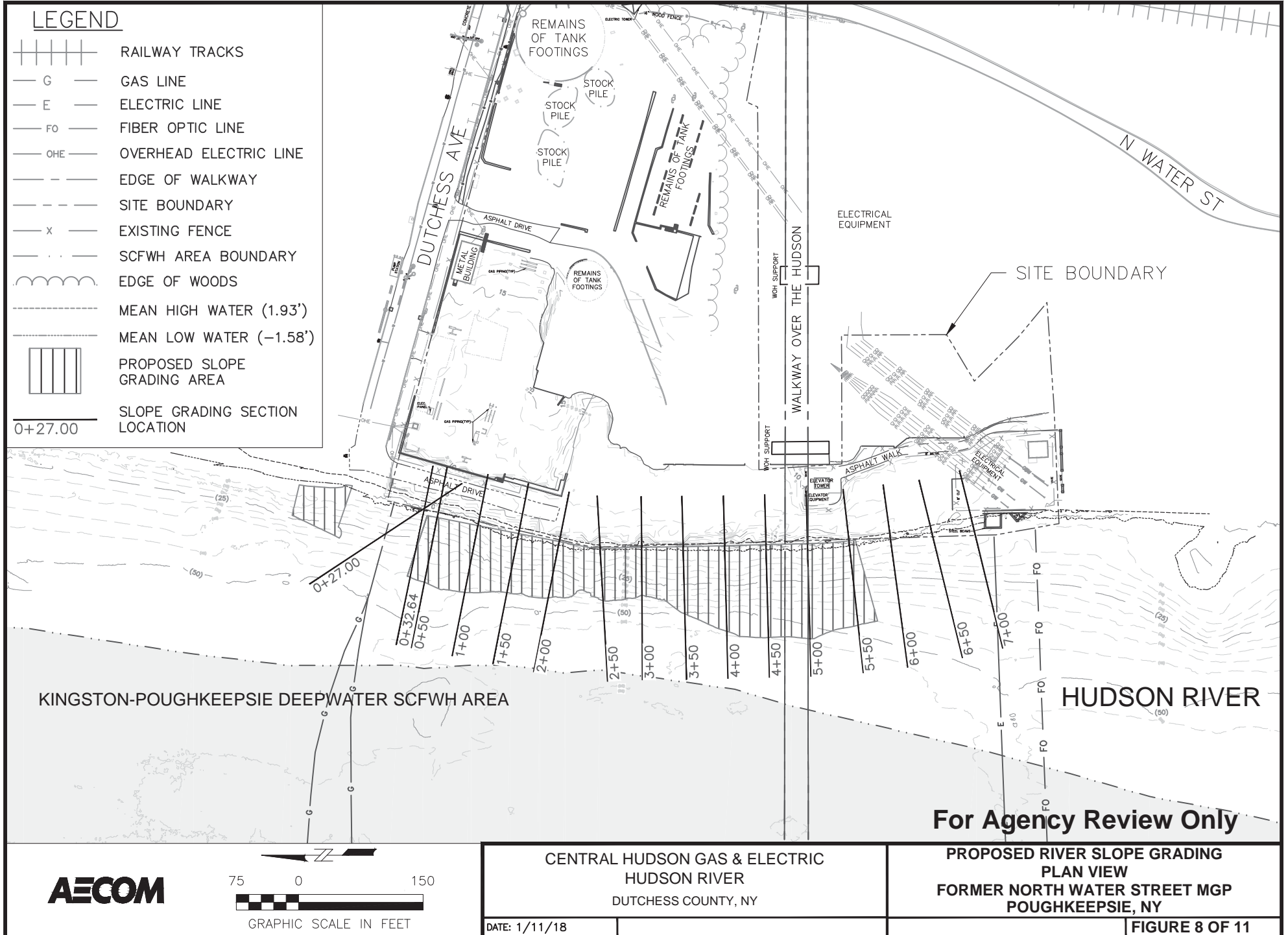





DREDGE AREA RESTORATION PLAN
FORMER NORTH WATER STREET MGP
POUGHKEEPSIE, NY

DATE: 1/11/18

FIGURE 7 OF 11

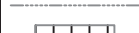

LEGEND

-  RAILWAY TRACKS
-  GAS LINE
-  ELECTRIC LINE
-  FIBER OPTIC LINE
-  OVERHEAD ELECTRIC LINE
-  EDGE OF WALKWAY
-  SITE BOUNDARY
-  EXISTING FENCE
-  SCFWH AREA BOUNDARY
-  EDGE OF WOODS
-  MEAN HIGH WATER (1.93')
-  MEAN LOW WATER (-1.58')
-  PROPOSED SLOPE GRADING AREA
-  SLOPE GRADING SECTION LOCATION

0+27.00

KINGSTON-POUGHKEEPSIE DEEPWATER SCFWH AREA

HUDSON RIVER

For Agency Review Only



CENTRAL HUDSON GAS & ELECTRIC
HUDSON RIVER
DUTCHESS COUNTY, NY

DATE: 1/11/18

PROPOSED RIVER SLOPE GRADING
PLAN VIEW
FORMER NORTH WATER STREET MGP
POUGHKEEPSIE, NY

FIGURE 8 OF 11

LEGEND

- ORIGINAL SLOPE SURFACE
- RESTORED CAP SURFACE
- . - . DREDGE SURFACE
- - - - - MEAN HIGH WATER (1.93')
- MEAN LOW WATER (-1.58')

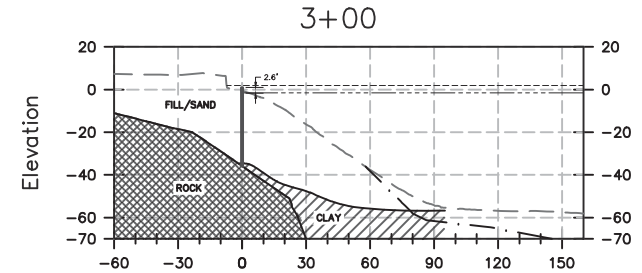
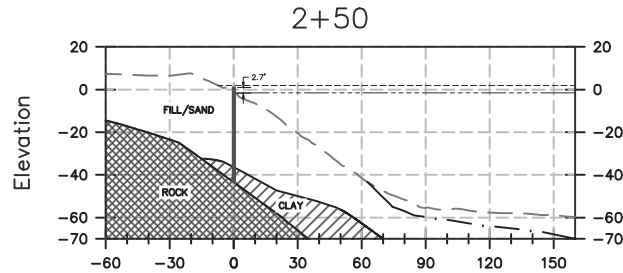
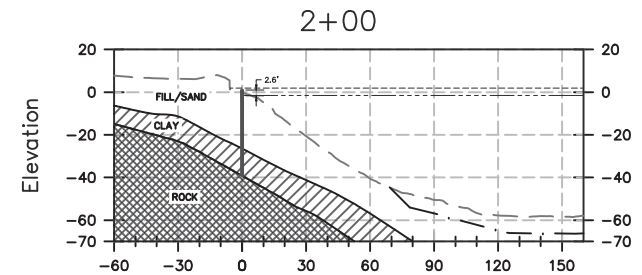
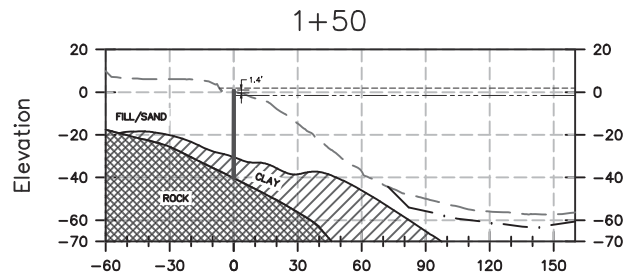
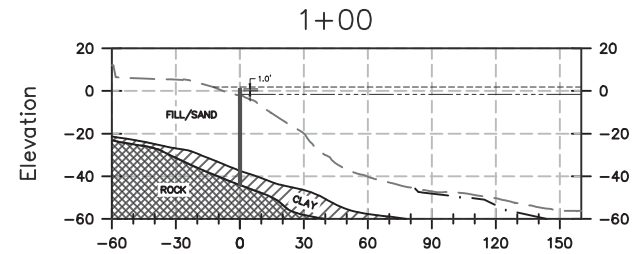
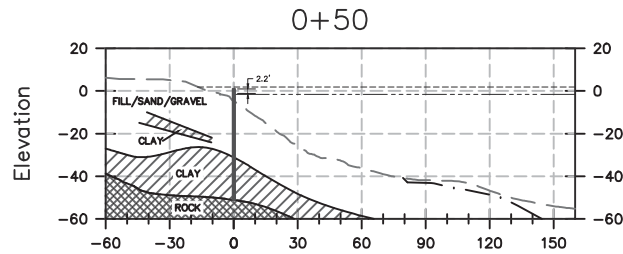
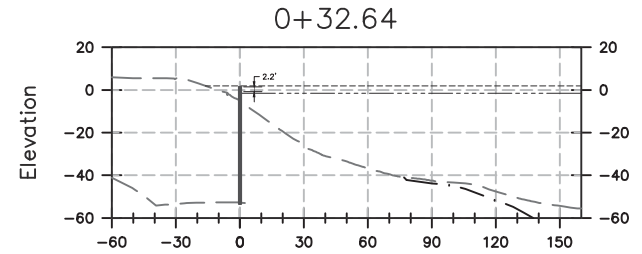
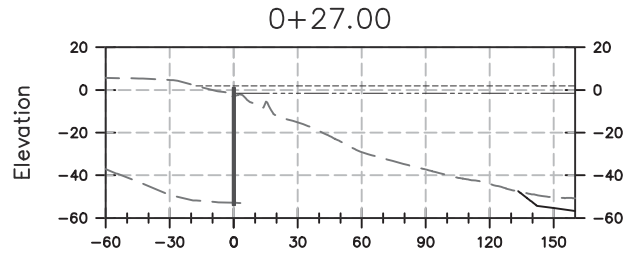

For Agency Review Only



CENTRAL HUDSON GAS & ELECTRIC
HUDSON RIVER
DUTCHESS COUNTY, NY

PROPOSED RIVER SLOPE GRADING
CROSS SECTIONS
FORMER NORTH WATER STREET MGP
POUGHKEEPSIE, NY

DATE: 1/11/18

FIGURE 9A OF 11

LEGEND

- ORIGINAL SLOPE SURFACE
- RESTORED CAP SURFACE
- · - · - DREDGE SURFACE
- - - - - MEAN HIGH WATER (1.93')
- MEAN LOW WATER (-1.58')

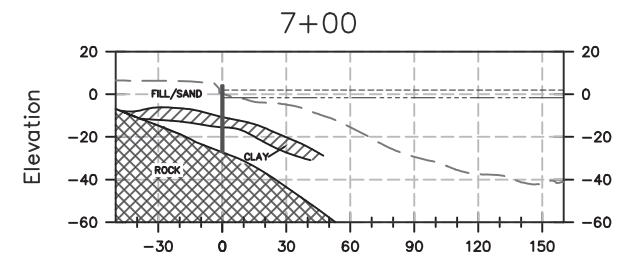
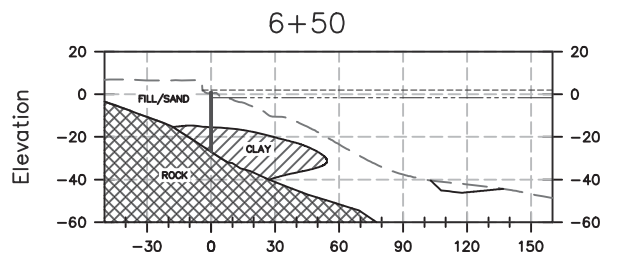
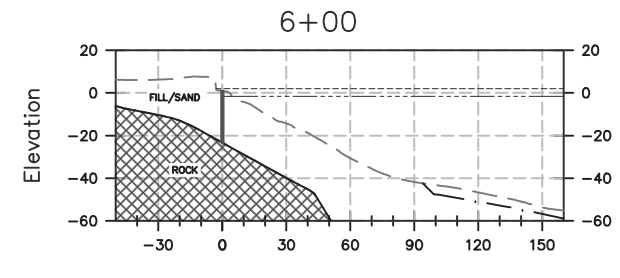
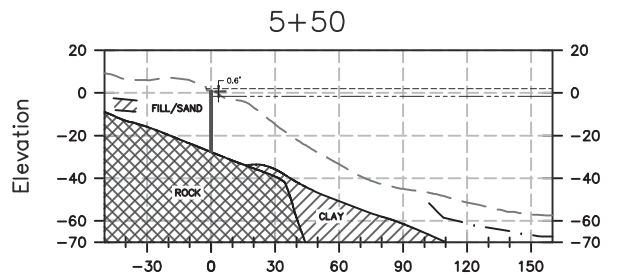
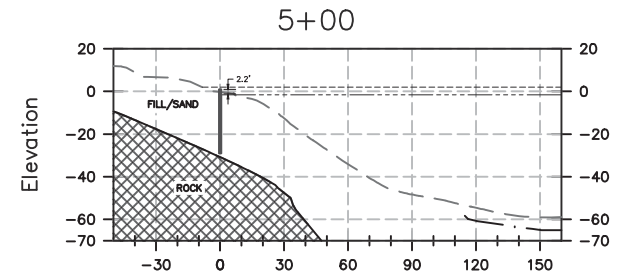
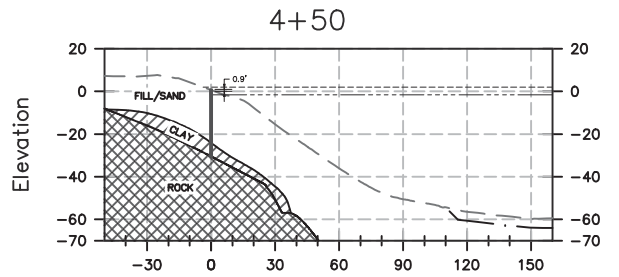
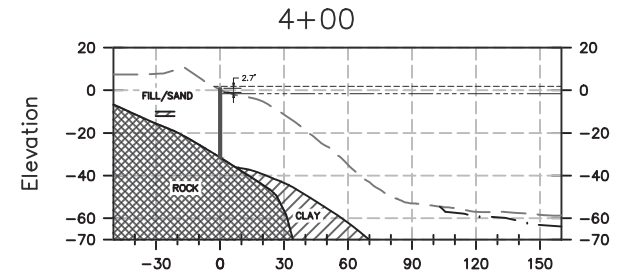
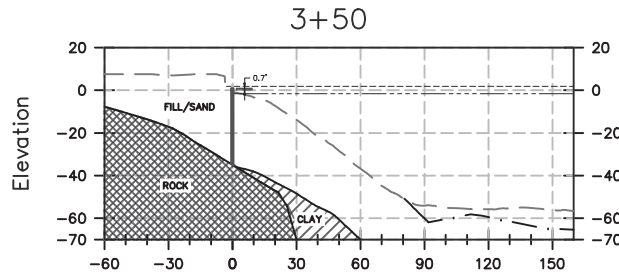

For Agency Review Only



CENTRAL HUDSON GAS & ELECTRIC
HUDSON RIVER
DUTCHESS COUNTY, NY

PROPOSED RIVER SLOPE GRADING
CROSS SECTIONS
FORMER NORTH WATER STREET MGP
POUGHKEEPSIE, NY

DATE: 1/11/18

FIGURE 9B OF 11

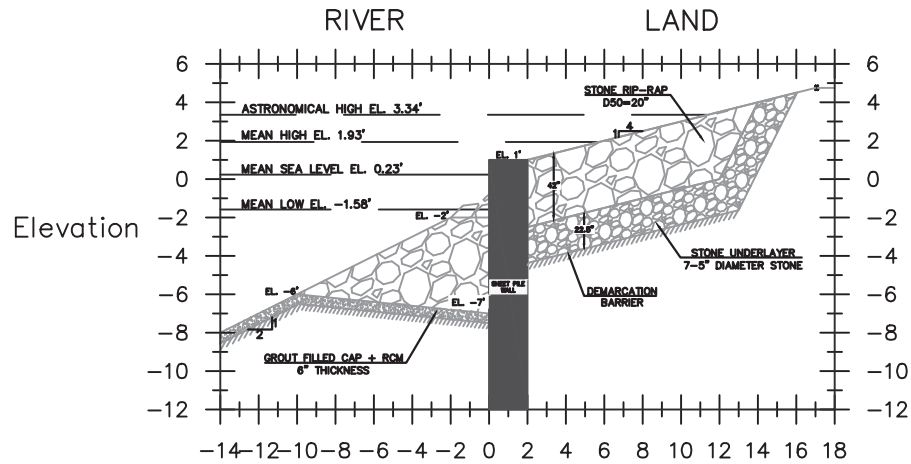

PROPOSED SIDE SLOPE RESTORATION

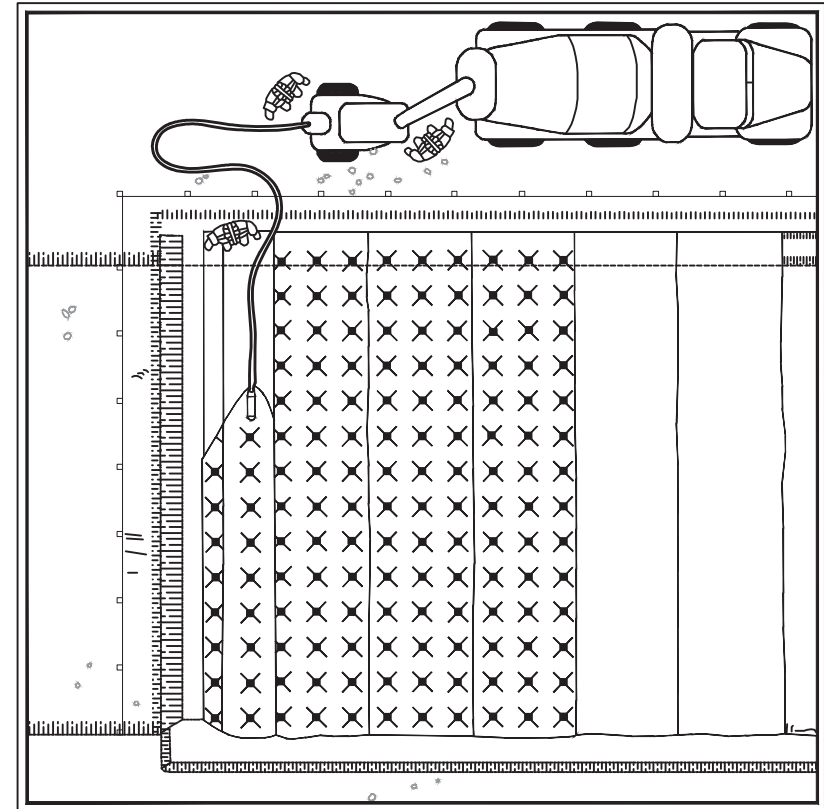

REACTIVE CORE MAT OVERLAID WITH CONCRETE MATTRESSES
ISOMETRIC VIEW

For Agency Review Only



CENTRAL HUDSON GAS & ELECTRIC
HUDSON RIVER
DUTCHESS COUNTY, NY

DETAILS FOR SIDE SLOPE CAP
FORMER NORTH WATER STREET MGP
POUGHKEEPSIE, NY

DATE: 1/11/18

FIGURE 10 OF 11

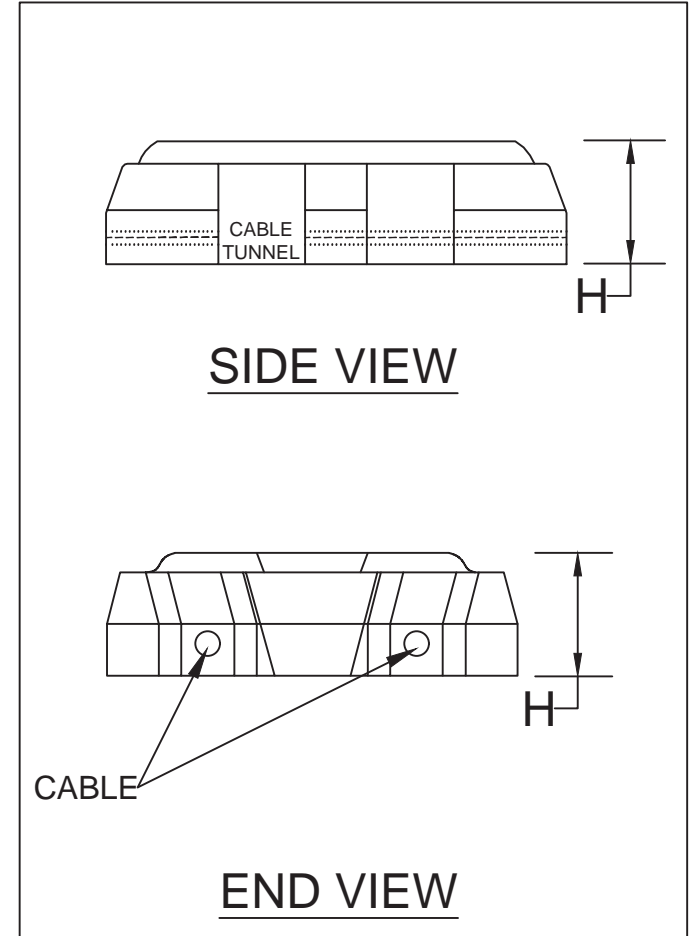
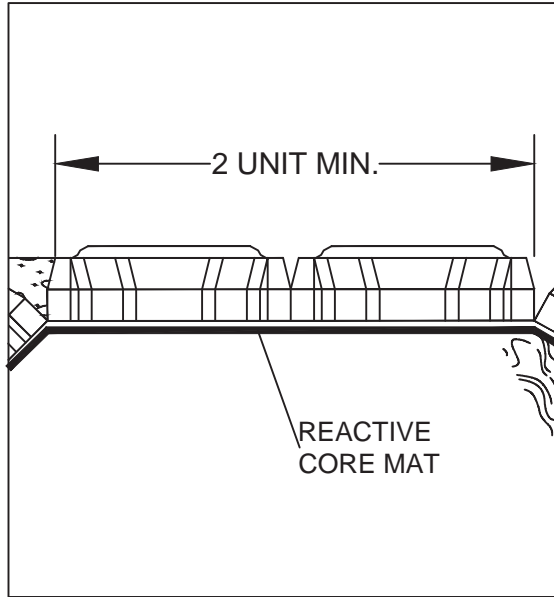
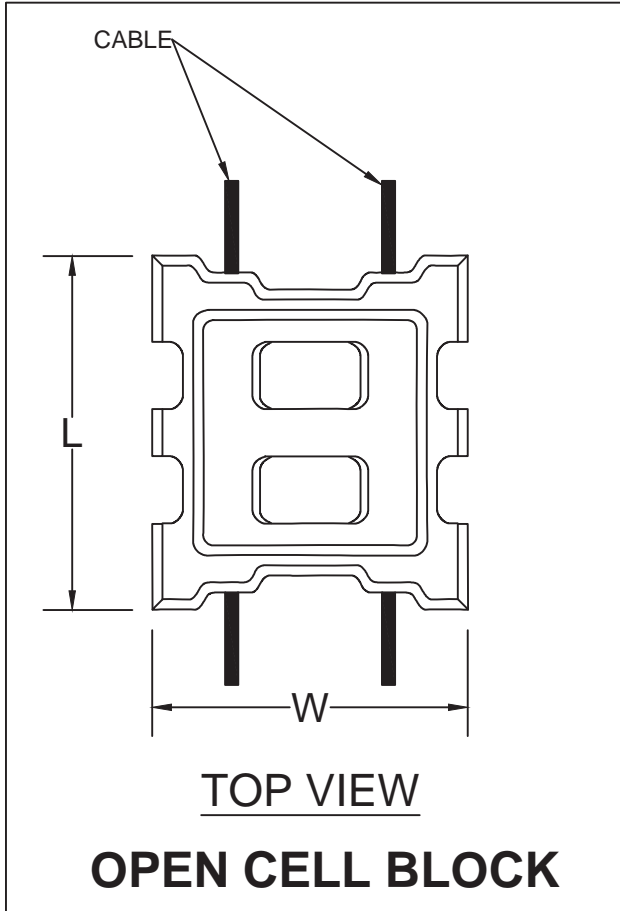

For Agency Review Only



CENTRAL HUDSON GAS & ELECTRIC
HUDSON RIVER
DUTCHESS COUNTY, NY

DETAILS FOR UTILITY CAP
FORMER NORTH WATER STREET MGP
POUGHKEEPSIE, NY

DATE: 1/11/18

FIGURE 11 OF 11

APPENDIX B

Product Description Sheets – Slope Stabilization Material

REACTIVE CORE MAT™

WITH ORGANOCLAY®

DESCRIPTION

ORGANOCLAY® REACTIVE CORE MAT™ is a permeable composite of geotextiles and granular ORGANOCLAY that reliably adsorbs NAPL and low solubility organics from water. Batch isotherm testing by a university determined the following partition coefficients:

- Naphthalene, Kd = 3280 L/kg
- Phenanthrene, Kd = 117,000 L/kg
- Pyrene, Kd - 286,000 L/kg

APPLICATION

ORGANOCLAY® REACTIVE CORE MAT™ is designed for use in the following applications:

- In situ subaqueous cap for contaminated sediments or post-dredge residual sediments
- Embankment seepage control
- Groundwater remediation

BENEFITS

- ORGANOCLAY® REACTIVE CORE MAT™ provides a reactive material that treats contaminants carried by advective/diffusive flow
- Reactive cap allows for thinner cap thickness than a traditional sand cap
- Geotextiles provide stability and physical isolation of contaminants

AVAILABILITY

ORGANOCLAY® REACTIVE CORE MAT™ is available from the following CETCO plant locations:

- 92 Highway 37, Lovell, WY



REACTIVE CORE MAT™ is designed to provide a simple method of placing active materials into subaqueous sediment caps.

PACKAGING

15' by 100' rolls, packaged on 4" PVC core tubes wrapped with polyethylene plastic packaging.

TESTING DATA

PHYSICAL PROPERTIES		
PROPERTY	TEST METHOD	RESULT
ORGANOCLAY¹		
Bulk Density Range	ASTM D 7481	44 - 56 lbs/ft ³
Oil Adsorption Capacity	CETCO Test Method	0.5 lb of oil per lb of ORGANOCLAY, min
Quaternary Amine Content	ASTM D 7626	25 - 33% quaternary amine loading
FINISHED RCM PRODUCT		
ORGANOCLAY Mass per Area	CETCO Test Method	0.8 lb/ft ²
Mat Grab Strength ²	ASTM D4632	90 lbs. MARV
Hydraulic Conductivity ³	ASTM D4491	1 x 10 ⁻³ cm/sec minimum

NOTES:

¹ ORGANOCLAY properties performed periodically on material prior to incorporation into the RCM

² All tensile testing is performed in the machine direction

³ Permittivity at constant head of 2 inches and converted to hydraulic conductivity using Darcy's Law and RCM thickness per ASTM D5199 for geotextiles

North America: 847.851.1800 | 800.527.9948 | www.CETCO.com

© 2014 CETCO. IMPORTANT: The information contained herein supersedes all previous printed versions, and is believed to be accurate and reliable. For the most up-to-date information, please visit www.CETCO.com. CETCO accepts no responsibility for the results obtained through application of this product. CETCO reserves the right to update information without notice.

UPDATED: NOVEMBER 2013

TDS_RCM-ORGANOCLAY_AM_EN_201311_v1



Armortec Product Details

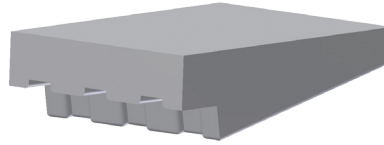

ArmorWedge[®]

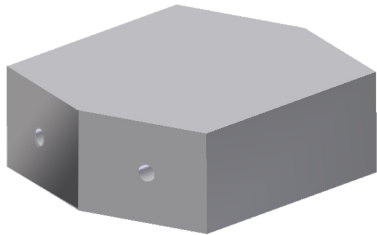

ArmorRoad[®]

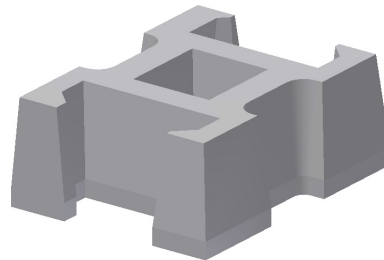

ArmorLoc[®]

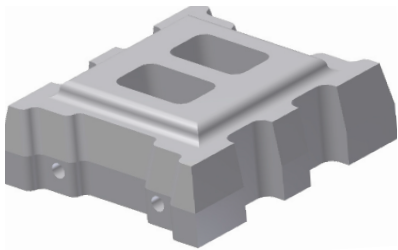

ArmorFlex[®] - Open Cell

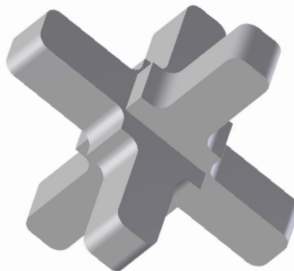

A-Jacks[®]

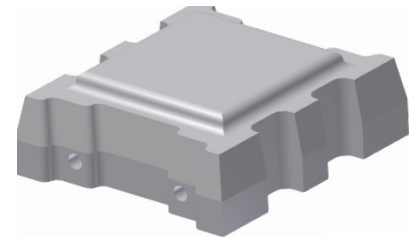

ArmorFlex[®] - Close Cell

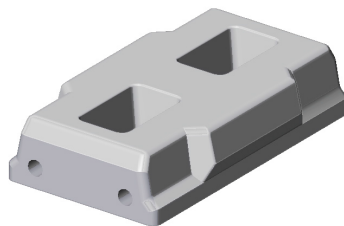

ArmorStone[®]

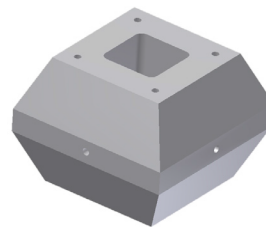

ArmorFlex[®] OS

MANUFACTURING SPECIFICATION
ASTM D6684-04

ArmorFlex® (not to scale)

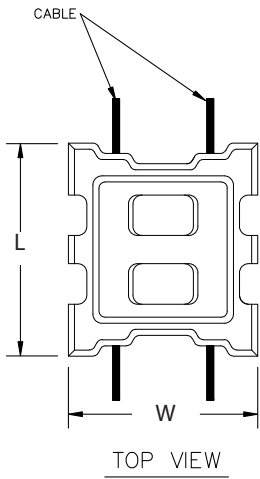

Open Cell Block

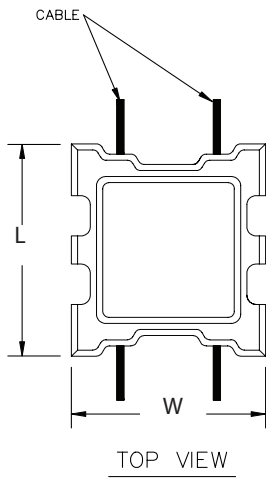

Close Cell Block

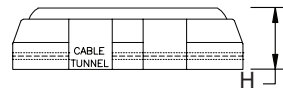

SIDE VIEW

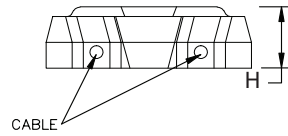

END VIEW

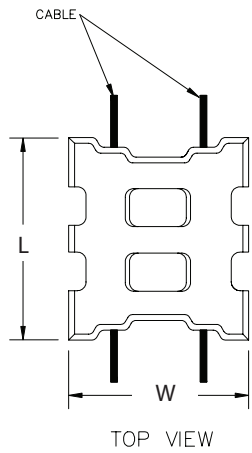

Tapered Series

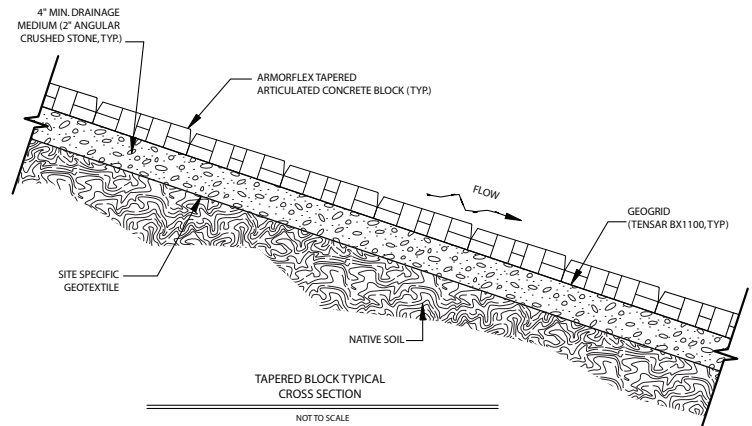
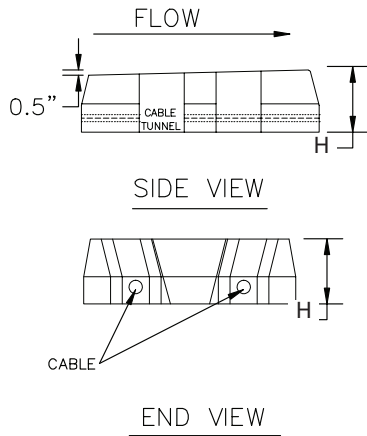

Tapered Series - Cross Section

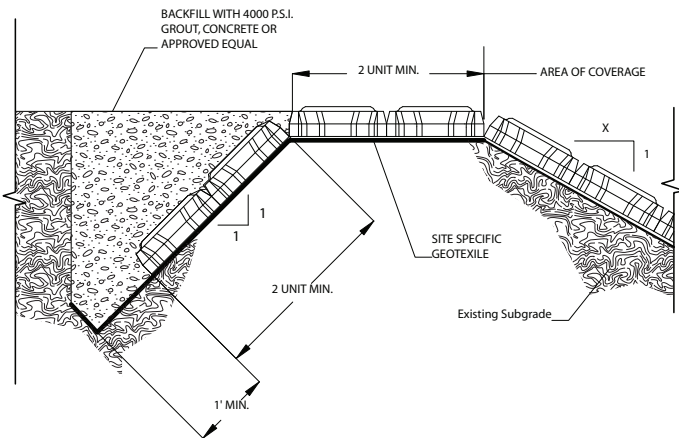

Top of Slope - Standard Detail

ArmorFlex Unit Specification

Concrete Block Class	Open/Closed Cell	Nominal Dimensions			Gross Area/ (sq. ft.)	Block Weight		Open Area %
		L	W	H		lbs	lbs/sq. ft.	
30s	Open	13.0	11.6	4.75	0.98	31-36	32-37	20
50s	Open	13.0	11.6	6.00	0.98	45-52	45-53	20
40	Open	17.4	15.5	4.75	1.77	62-71	35-40	20
50	Open	17.4	15.5	6.00	1.77	81-94	46-53	20
70	Open	17.4	15.5	8.50	1.77	120-138	68-78	20
40L	Open	17.4	23.6	4.75	2.58	90-106	35-41	20
70L	Open	17.4	23.6	8.50	2.58	173-201	67-78	20
45s	Closed	13.0	11.6	4.75	0.98	39-45	40-45	10
55s	Closed	13.0	11.6	6.00	0.98	53-61	54-62	10
45	Closed	17.4	15.5	4.75	1.77	78-89	43-50	10
55	Closed	17.4	15.5	6.00	1.77	94-108	53-61	10
85	Closed	17.4	15.5	8.50	1.77	145-167	82-98	10
45L	Closed	17.4	23.6	4.75	2.58	108-126	42-49	10
85L	Closed	17.4	23.6	8.50	2.58	209-243	81-94	10

High Velocity Application Block Classes

40-T	Open	17.4	15.5	4.75	1.77	62-71	35-40	20
50-T	Open	17.4	15.5	6.00	1.77	81-94	46-53	20
70-T	Open	17.4	15.5	8.50	1.77	120-138	68-78	20

ArmorFlex® cont. (not to scale)

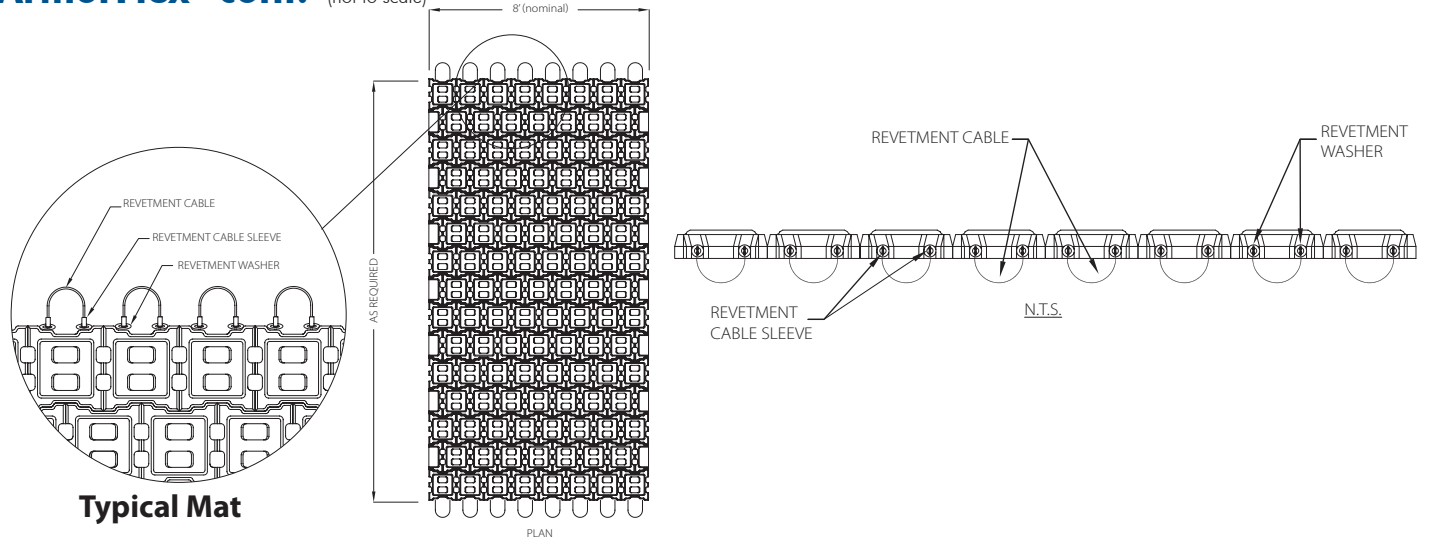

A-Jacks® (not to scale)

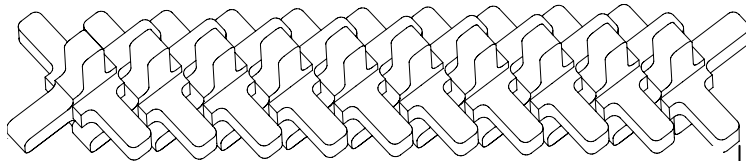

A-Jacks Placement Profile

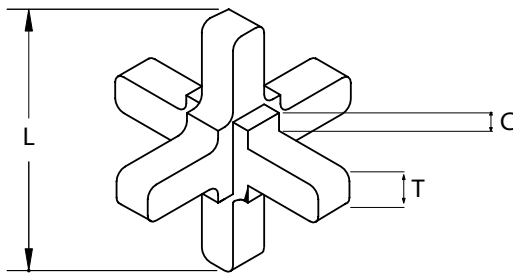

A-Jacks Unit

A-Jacks Unit Specification

A-JACKS	L(IN)	T(IN)/H(IN)	C(IN)	VOL(FT³)	WT (LBS)
AJ-24	24	4	1.84	0.56	78
AJ-48	48	7.36	3.68	4.49	629
AJ-72	72	11.04	5.52	15.14	2.120
AJ-96	96	14.72	7.396	35.87	5.022
AJ-120	120	18.40	9.20	70.69	9.699

ArmorWedge® (not to scale)

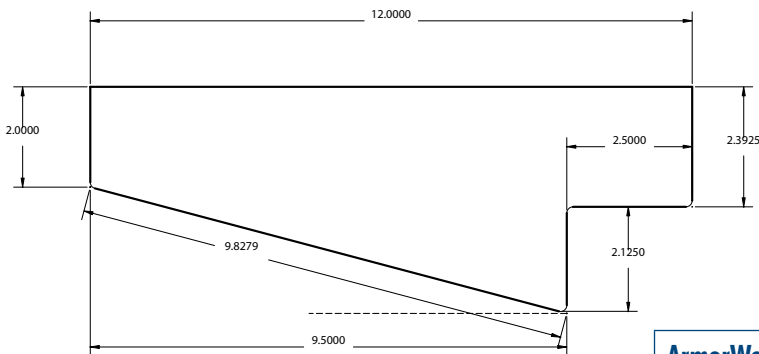

Side View - Typical Block

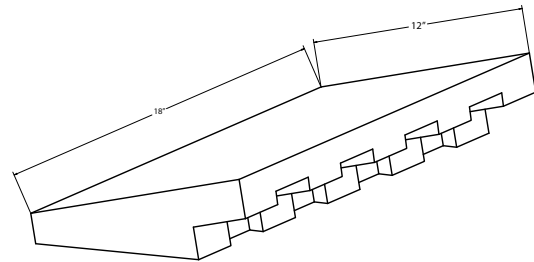

ArmorWedge Unit Specification

UNIT DIMENSION	UNIT WEIGHT (LBS)	SYSTEM WEIGHT (LBS)	UNIT COVERAGE (SF)	COMPRESSIVE STRENGTH (PSI)	MAXIMUM ABSORPTION (LBS/FT³)
12x18	40-52	36-40	1.1875	4000	12

ArmorLoc® (not to scale)

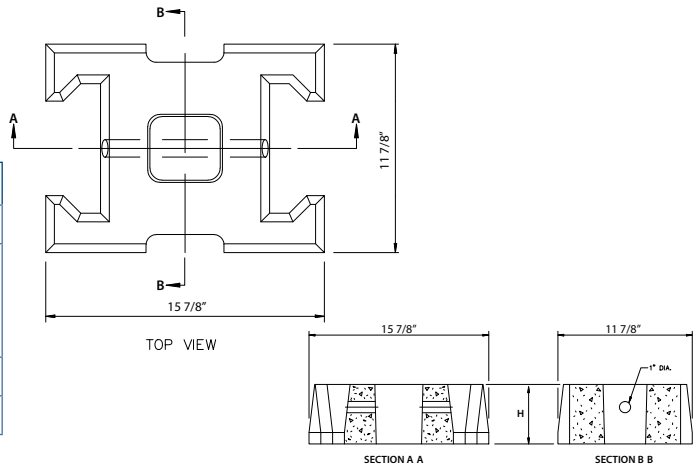

ArmorLoc Unit Specification

BLOCK	TECHNICAL DATA			DIMENSIONS AND WEIGHTS				
	Specific Weight lbs/ft ³	Compressive Strength psi	Max Absorption, Avg. of 3 units 10 lbs/ft ³	Thickness Inches (H)	Gross Area/ Grid ft ²	Weights/ Grid lbs	Weights/ Area lbs/ft ²	Open Area %
3510	130-150	4000 min	10	4	1.0	30-35	30-35	25
4511	130-150	4000 min	10	5.25	1.1	44-50	40-45	20

ArmorStone® (not to scale)

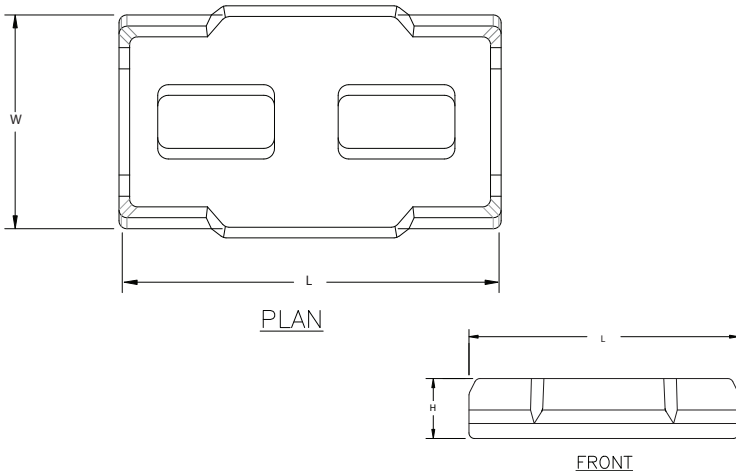

ArmorStone Unit Specification

CONCRETE BLOCK CLASS		NOMINAL DIMENSIONS (IN.)			UNIT COVERAGE (SF)	BLOCK		OPEN AREA %
		L	W	H		UNIT WEIGHT LBS.	SYSTEMS WEIGHTS LBS./SF	
AS 40	Open	18.00	10.00	4.50	1.25	50-54	40-44	25
AS 55	Closed	18.00	10.00	4.50	1.25	61-66	49-53	5

ArmorRoad® (not to scale)

ArmorRoad Unit Specification

BLOCK	TYPE	L	W	H	SF COVERAGE PER UNIT	WEIGHT LBS PER UNIT	SF PER TRUCK LOAD
Mat	Closed	18.00	15.60	6.00	1.74	105-109	750
Individual	Closed	18.00	15.60	6.00	1.74	100-104	750

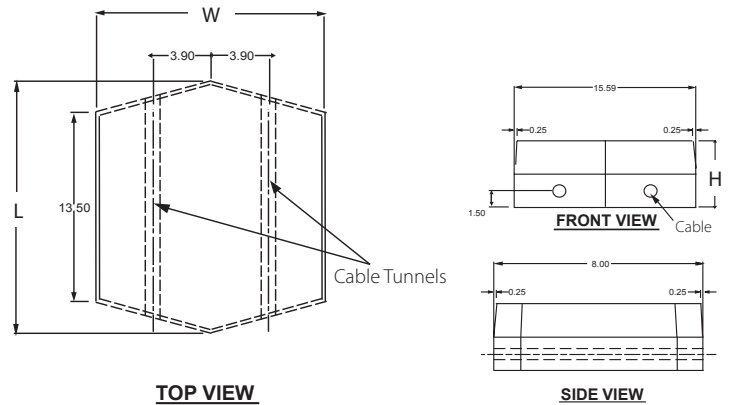

Armortec Minimum Physical Requirements per ASTM 06684-04

MIN. DENSITY (IN AIR) LBS/FT ³		MIN. COMPRESSIVE STRENGTH PSI		MAX WATER ABSORPTION LBS/FT ³	
Ave. of 3 Units	Individual Unit	Ave. of 3 Units	Individual Unit	Ave. of 3 Units	Individual Unit
130	125	4,000	3,500	9.1	11.7

**BIOLOGICAL ASSESSMENT
ADDRESSING THE PROPOSED
CENTRAL HUDSON GAS & ELECTRIC CORPORATION
FORMER NORTH WATER STREET MANUFACTURED GAS
PLANT REMEDIATION PROJECT
POUGHKEEPSIE, DUTCHESS COUNTY, NY**

U.S. ARMY CORPS OF ENGINEERS

JANUARY 2018

This page intentionally left blank.

Table of Contents

1.	Introduction.....	1-1
1.1	Endangered Species Act Requirements	1-1
1.2	Consultation History	1-2
2.	Site Location and History.....	2-1
3.	Description of the Proposed Action.....	3-1
3.1	Barrier Wall	3-1
3.2	Dredging and Capping	3-1
3.3	Restrictions on Use of the Dredged Areas	Error! Bookmark not defined.
3.4	Regulatory Jurisdiction	3-1
3.5	Description of Construction Methods.....	3-1
3.6	Construction Schedule	3-5
4.	Federally Listed Species and Designated Critical Habitat.....	4-1
4.1	Aquatic Species.....	4-1
4.1.1	Marine Mammals	4-1
4.1.2	Marine Reptiles.....	4-1
4.1.3	Marine Fishes.....	4-1
4.1.4	Aquatic Invertebrates.....	4-13
4.2	Terrestrial Species.....	4-13
5.	Environmental Baseline Conditions.....	5-1
5.1	Hudson River	5-1
5.1.1	Deepwater Habitat	5-1
5.1.2	Benthic Habitat	5-2
5.1.3	Submerged Aquatic Vegetation	5-2
6.	Potential Effects on Federally Listed Aquatic Species	6-1
6.1	Shortnose Sturgeon and Atlantic Sturgeon	6-1
6.2	Impacts on Sturgeon Prey.	6-3
7.	Remediation Activities in the Hudson River	7-1
8.	Conclusions.....	8-1
8.1	Effects Determination for Listed Species	8-1
8.2	Effects Determination for Critical Habitat.....	8-1
9.	References.....	9-1

Appendix A Dredging Figures

Appendix B Product Description Sheets – Slope Stabilization Material

List of Figures

Figure 1	Site Location.....	2-2
Figure 2	Bathymetric Contours.....	2-3
Figure 3	Dredge Areas.....	3-2
Figure 4	Silt Curtain.....	3-4
Figure 5	Benthic Invertebrate Sample Locations.....	4-7

List of Tables

Table 1	GARFO Master ESA Species Table - Shortnose Sturgeon.....	Error! Bookmark not defined.
Table 2	Benthic Invertebrates – Project Area.....	4-8
Table 3	GARFO Master ESA Species Table - Atlantic Sturgeon.....	4-12
Table 4	Summary of Impacts on Federally Listed Species by Resource Area.....	6-2
Table 5	Determination of Effect under the ESA for Federally Listed Aquatic Species in the Proposed CHGE Project Area.....	6-3

1. Introduction

The purpose of this Biological Assessment (BA) is to evaluate the potential impacts of the proposed Central Hudson Gas & Electric Corporation (CHGE) North Water Street former Manufactured Gas Plant (MGP) Site (site) Remediation Project (NWS MGP Remediation Project) on federally listed threatened or endangered species and to comply with the requirements of the Endangered Species Act (ESA) of 1973 (16 United States Code [U.S.C.] 1531–1534).

The U.S. Army Corps of Engineers (USACE) has a Federal action related to the implementation of the NWS MGP Remediation Project regarding issuance of a Rivers and Harbors Act Section 10 and Clean Water Act Section 404 permit. Other cooperating agencies involved with the BA process include the National Marine Fisheries Service (NMFS) and New York State Department of Environmental Conservation (NYSDEC). CHGE proposes to remediate the Former North Water Street Manufactured Gas Plant (MGP) site in Poughkeepsie, Dutchess County, New York in accordance with the Brownfield Cleanup Agreement (BCA) Index Number D3-0004-99-04 executed between CHGE and the NYSDEC in May 2005. Additionally, the NYSDEC selected remedy to address the environmental impacts identified at the site and in the Hudson River adjacent to the site is presented in the March 2016 *Decision Document*.

1.1 Endangered Species Act Requirements

The ESA establishes procedures for the protection and conservation of threatened and endangered species and the ecosystems upon which they depend. The ESA describes several categories of Federal status for plants and animals and their critical habitat which have been designated by the US Fish and Wildlife Service (USFWS) or NMFS. In addition to allowing the listing of species and subspecies, the ESA allows listing of “distinct population segments” (DPSs) of vertebrate species. An “endangered” species is defined as any species in danger of extinction throughout all or a large portion of its range. A “threatened” species is defined as any species likely to become an endangered species in the foreseeable future. “Critical habitat” is defined in the ESA as “a specific geographic area that is essential for the conservation of a threatened or endangered species and that could require special management or protection. Critical habitat can include an area that is not occupied by a species but is needed for the recovery of that species.

USFWS and NMFS share responsibility for implementing the ESA. Generally, the USFWS manages terrestrial and freshwater species, while NMFS manages marine and “anadromous” (i.e., born in fresh water, spends most of its life in the sea, and returns to fresh water to spawn) species. In the case of sea turtles, NMFS has the lead in the marine environment, while USFWS does on the nesting beaches.

Federal agencies must consult with USFWS and NMFS, under Section 7(a)(2) of the ESA, on activities that may affect a listed species. These interagency consultations, or Section 7 consultations, are designed to assist Federal agencies in fulfilling their duty to ensure Federal actions do not jeopardize the continued existence of a species or destroy or adversely modify critical habitat.

1.2 Consultation History

The following interactions between CHGE and USFWS or NMFS associated with the proposed CHGE Project have occurred prior to the preparation of this BA and have supported its development:

- **November 7, 2017** – Requested listing of protected species that may occur in the location of the proposed project from USFWS Information and Planning (IPaC) Website (<https://ecos.fws.gov/ipac/location/SQW6PRTQANHH5CSGMSENVWLWCA/resources>)
- **November 7, 2017** – Response letter from USFWS that provided list of threatened, endangered, proposed and candidate species, as well as proposed and final designated critical habitat, that may occur within the boundary of the proposed project and/or may be affected by the proposed project.
- **November 13, 2017** – Letter sent on behalf of CHGE to NMFS to request information on protected species that may occur in the location of the proposed project.
- **November 16, 2017** – Response letter sent by NMFS provided information on protected species that may occur in the location of the proposed project.

2. Site Location and History

The CHGE former North Water Street MGP is located at 2 Dutchess Avenue in the City of Poughkeepsie, Dutchess County, New York (Figure 1). The site is bounded by Dutchess Avenue to the north, North Water Street and Amtrak railroad lines to the east, the City of Poughkeepsie Upper Landing Park, and Fall Kill Creek to the south and Hudson River to the west. Tidal movements affect the Hudson River adjacent to the site. Figure 2 depicts the bathymetric contours of the Hudson River adjacent to the shoreline on the CHGE property.

The site was operated as a carbureted water gas MGP from 1911 to 1950. CHGE owned the site since 1926. During peak operation, waste by-products were recycled at the site and during this process, by-products were reported to have seeped into the Hudson River from unintentional spills near the tar separator. To prevent additional seepage of by-products into the river, a clay dike was installed between the railroad siding and the river in the 1940s.

The following section summarizes the key elements of the NWS MGP Remediation Project to be conducted along the shoreline and in the Hudson River adjacent to the site, which was drawn from the NYSDEC Decision Document (March 2016).

File: P:\Jobs\Rem_Eng\Project Files\CHGE\CAUD\CHGE-60540671-SL-01.dwg Layout: Layout2 User: warrenr Plotted: Jul 20, 2017 - 3:37pm Xref's:

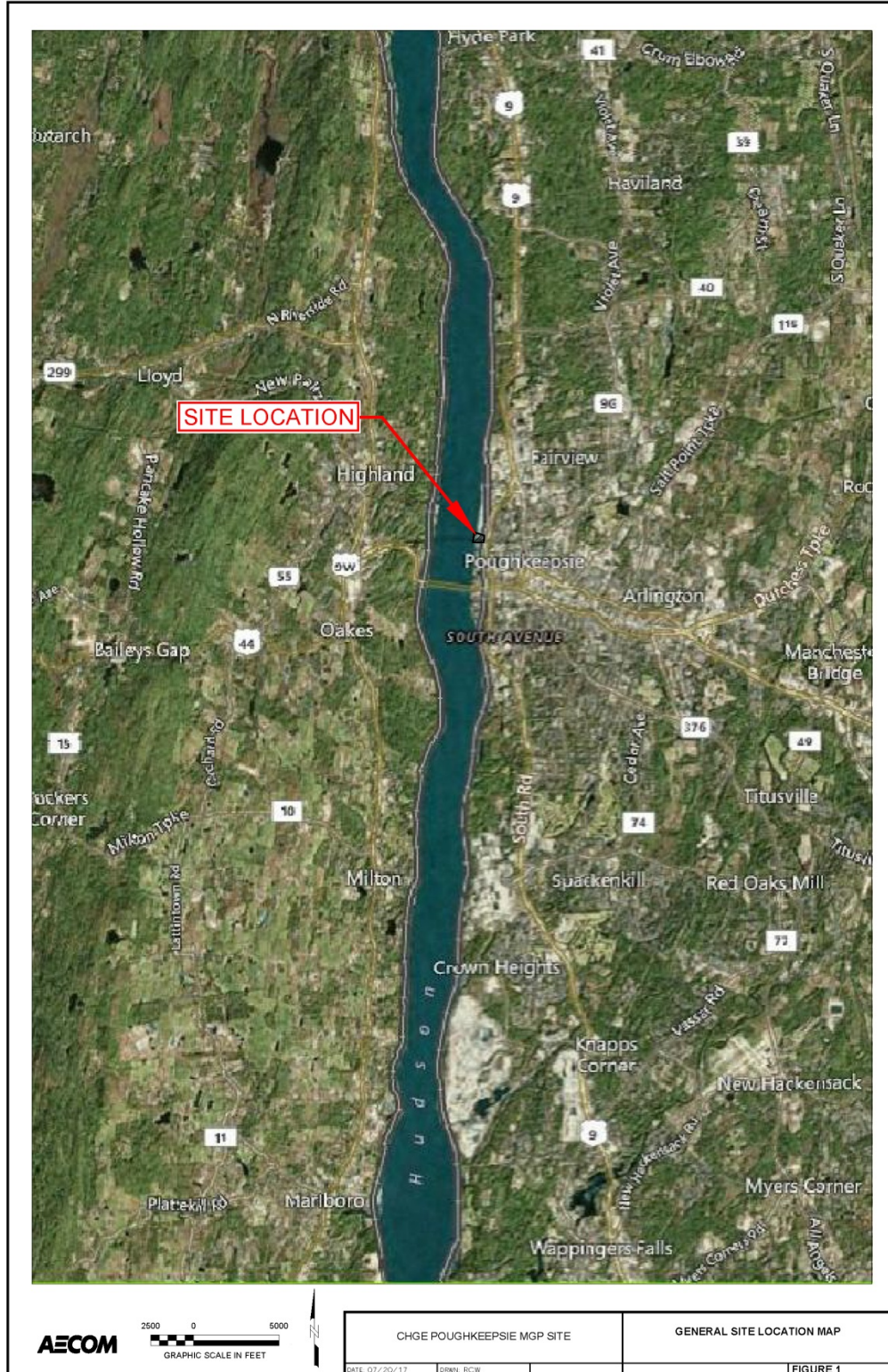

Figure 1 Site Location

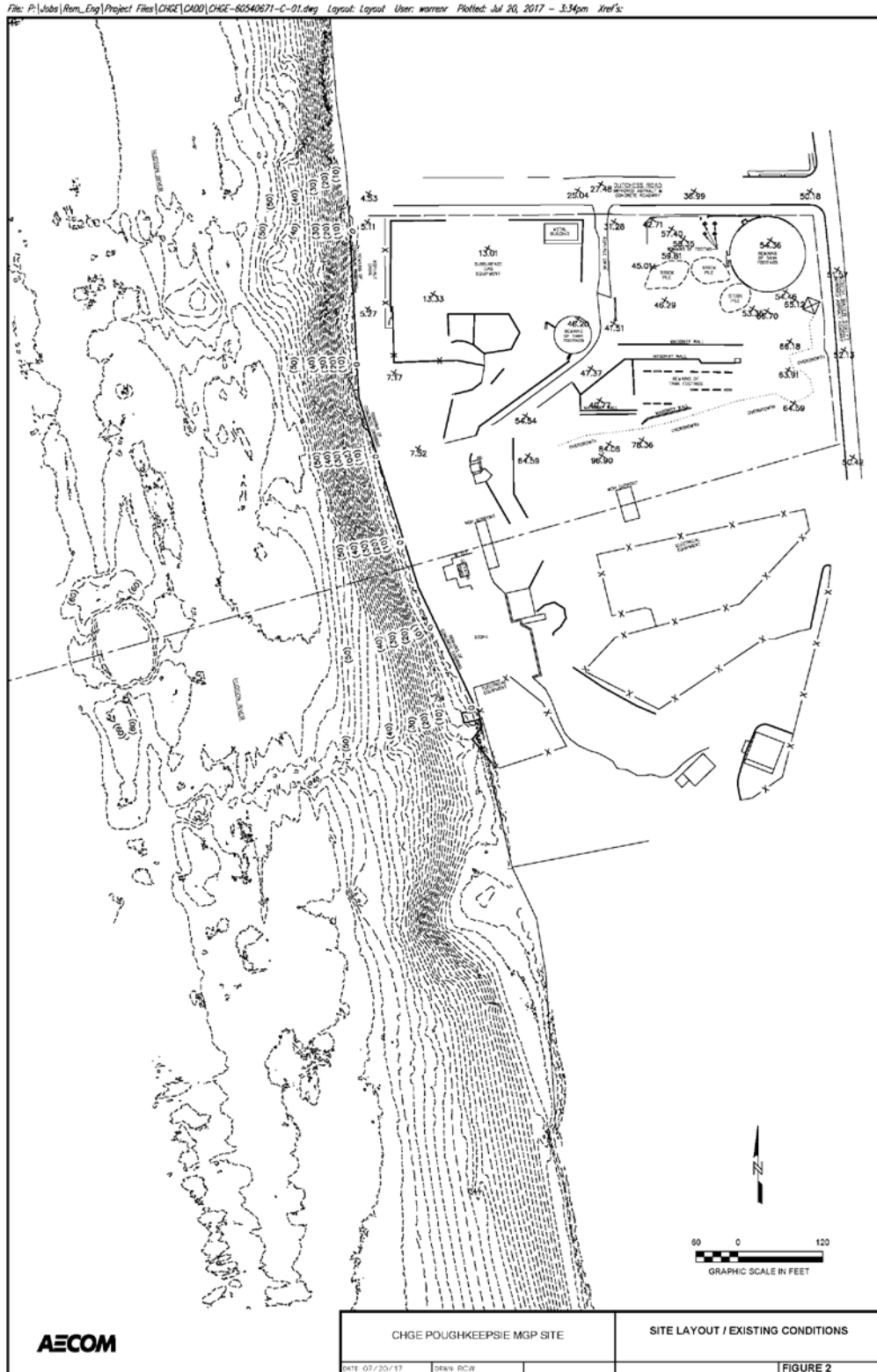

Figure 2 Bathymetric Contours

3. Description of the Proposed Action

The selected remedial actions for the shoreline and in the Hudson River include:

3.1 Barrier Wall

To prevent migration of coal tar to the river, installation of a subsurface barrier wall along the east bank of the Hudson River will be conducted. Subsequently, there will be the installation of a series of non-aqueous phase liquid (NAPL) recovery wells to collect NAPL that might accumulate behind the wall. NAPL will be collected from these recovery wells periodically.

3.2 Dredging and Capping

To remove NAPL impacted sediments from the bed of Hudson River, dredging will be conducted where feasible (Figure 3). A full set of dredging figures that depicts the various dredge areas, capping and methods is provided in Appendix A. A sand cap will be placed in select dredged areas. In areas of impacted sediment near and above the underwater utility crossings, where dredging cannot be performed, the placement of cover system consisting of Reactive Core-Mats (RCM) overlain by armored concrete blocks will be conducted (examples of sediment/slope stabilization materials are provided in Appendix B).

In areas of impacted sediment along the riverbank slope where dredging would create significant safety concerns due to potential for slope instability, an articulated capping system will be placed consisting of RCM with grout filled molds (Appendix B). The capping system will prevent migration of the remaining contamination in the riverbank into the Hudson River.

3.3 Regulatory Jurisdiction

The dredging and capping activities in the Hudson River and along the river shoreline slope are subject to the jurisdiction of the USACE. Approximately 7.6 acres of dredging (Figure 3) will be conducted in the Hudson River to remove approximately 40,000 cubic yards (CYs) of sediment impacted by the operation of the former MGP facility. There will also be approximately 1.2 acres of capping along the riverbank slope and over the utility crossings (Figure 4)

3.4 Description of Construction Methods

Dredging will be conducted using an environmental bucket within a containment cell. The containment cell will be attached to the dredge-mounted barge which will be outfitted with turbidity curtains and

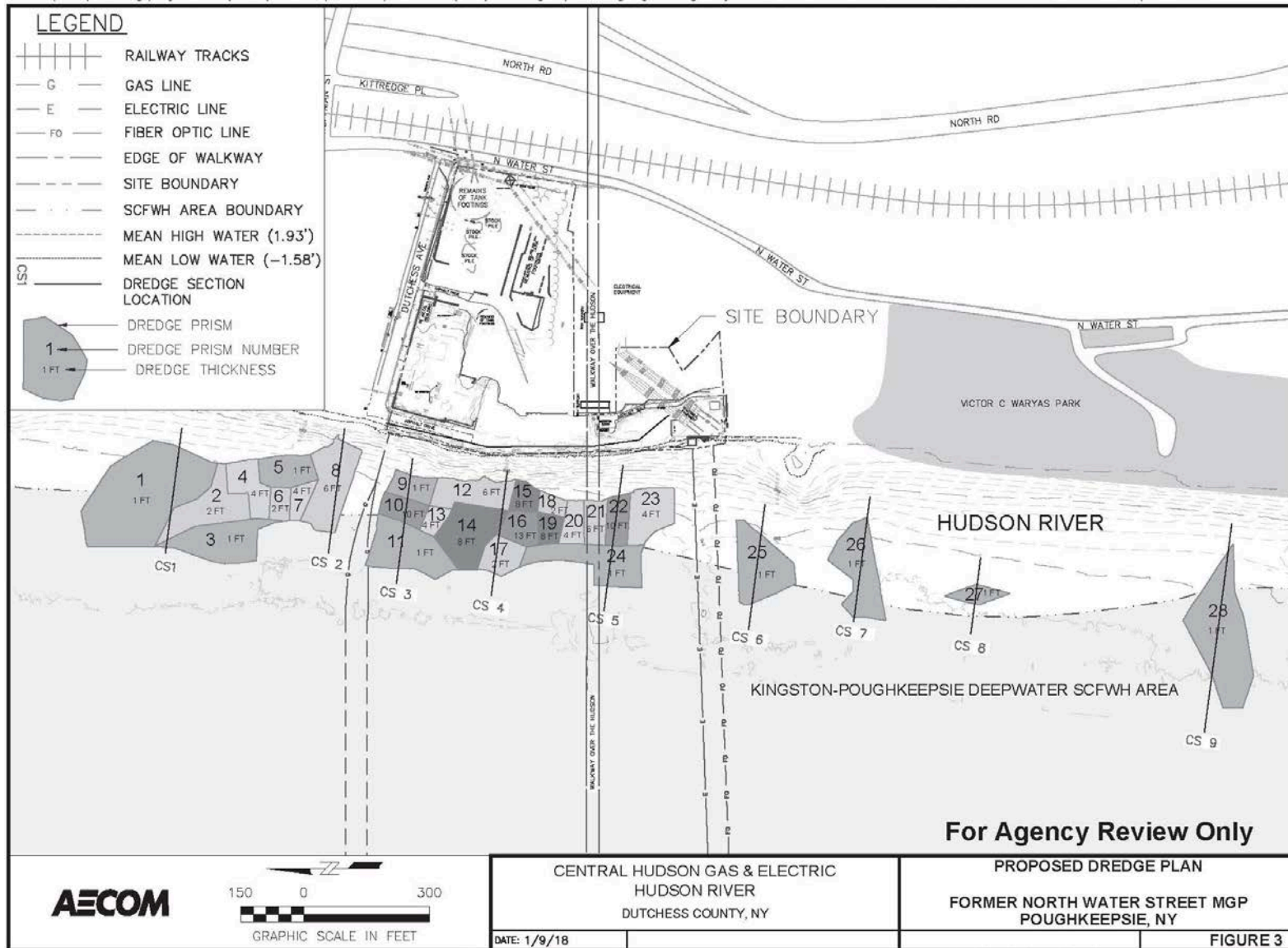

Figure 3 Dredge Areas (Proposed Dredge Plan)

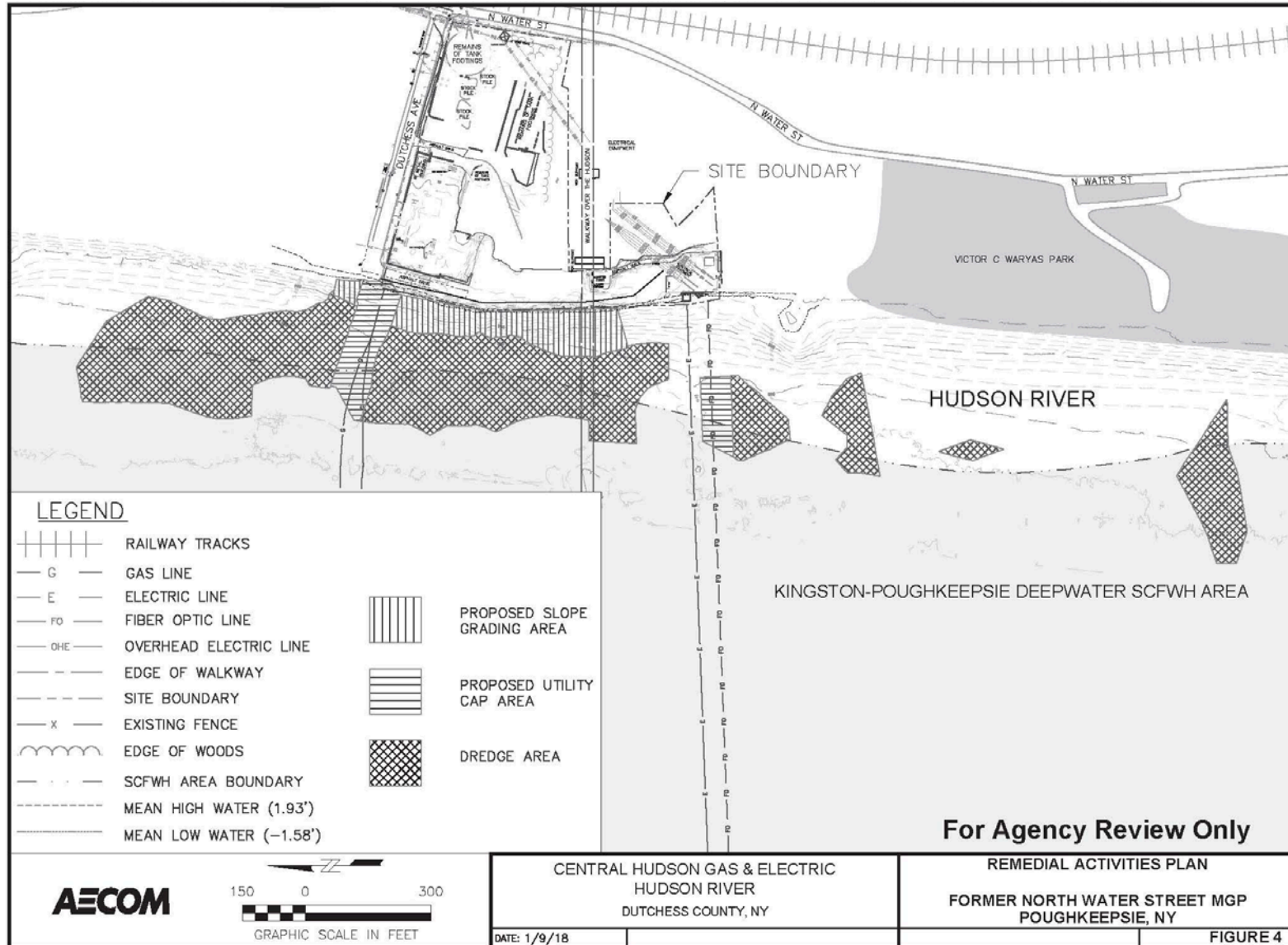

Figure 4 Dredge and Capping Areas

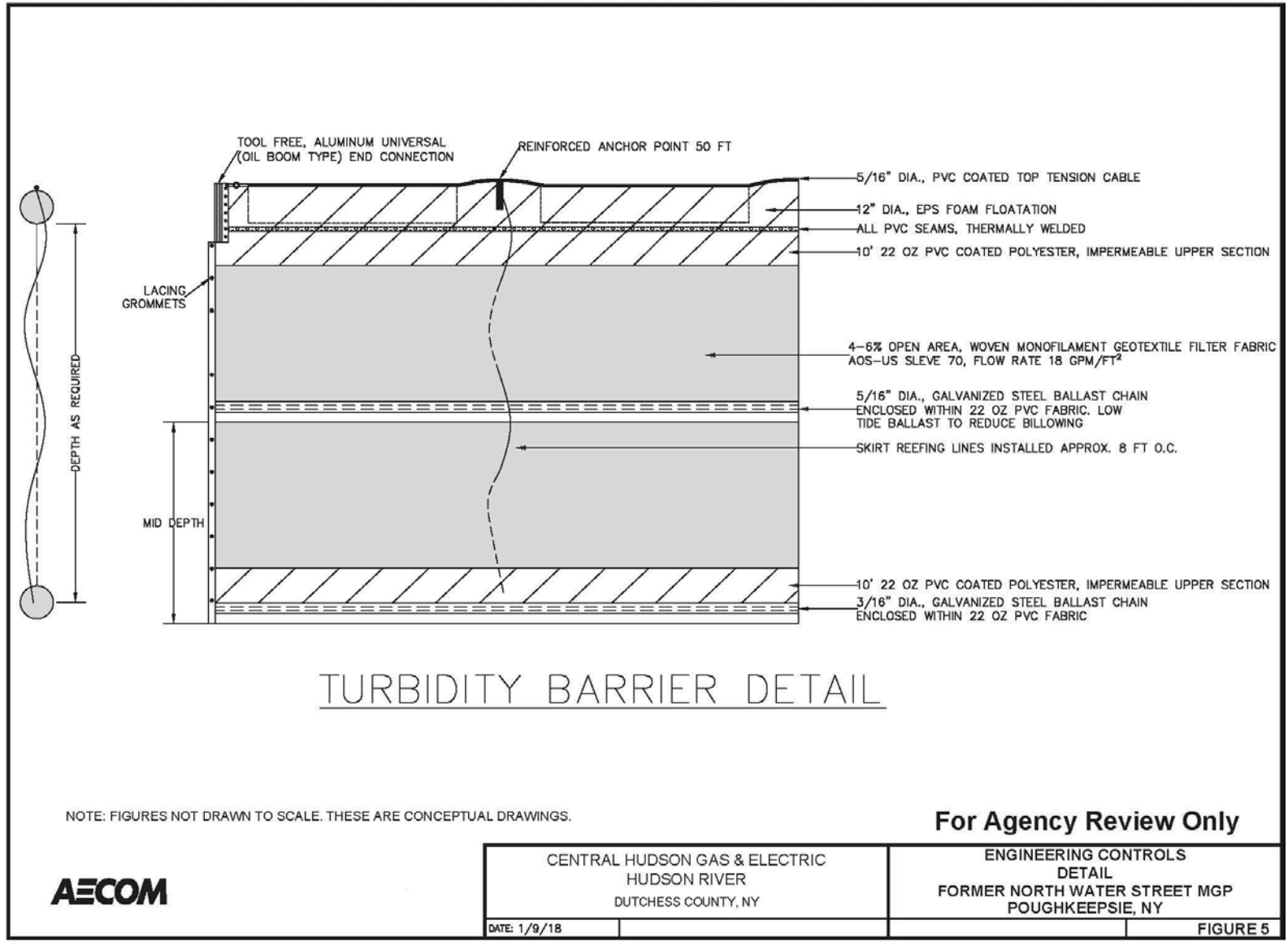

Figure 5 Silt Curtain

floating booms on all sides of the dredge polygon (Figure 5) to control the transport of contaminated sediment beyond the dredging area. Water quality (turbidity) will be monitored for the duration of the dredging by means of three buoy-mounted remote sensing stations that will be moored around the perimeter of the work area.

Dredged areas deeper than 2 feet below the existing bathymetry will be backfilled after dredging with certified clean sand (approximately 31,000 CYs) imported from upland sources and transported to the site via barge. The clean sand will be placed on approximately 4.2 acres of the dredged areas using specially fabricated conveyors and tremie technology that will discharge the sand from a tremie pipe. To the extent practicable, the tremie pipe will be constructed to extend above the dredge surface. The clean sand backfill will be placed in the dredged areas to within 2 feet of the adjacent bottom elevation to support the restoration of the river bottom to pre-dredge bathymetry. The sand will consist of a granular material of sufficient size and density that it is expected to fall through portion of the water column beyond the tremie pipe to the river bottom at its placement location with minimal dispersion. Clean sand was selected specifically to maximize accuracy of the fill placement operation and minimize suspension and transport of backfill material outside of the intended placement location.

The river bottom will be allowed to reestablish its original (pre-dredging) bathymetry within the dredged areas by natural sediment transport processes. Sediment deposition and subsequent erosion is a natural cycle within a stable riverbed; while specific rates of sedimentation and erosion in the vicinity of Poughkeepsie are not available, sedimentation rates of approximately 40 centimeters (1.3 feet) within a period of months (typically, during the spring freshet) are observed within the Lower Hudson River as a whole. Dredging of the impacted sediment will create areas of the river bottom below the surrounding bathymetry and function as natural sediment traps; consequently, it is expected that sediment transport within the dredged areas will only be depositional in nature until the pre-existing stable bathymetry is restored, after which the natural long-term deposition and erosion cycle will resume.

The slope of the shoreline along the bulkhead cannot be dredged to remove impacted sediment due to the shallow depth and stability issues with the slope. A steel sheet pile bulkhead wall will be installed as part of the upland and bulkhead remediation activities. To isolate the impacted sediment remaining beyond the sheet pile bulkhead wall from the river, approximately 1.22 acres of an articulated capping system consisting of RCM with grout filled molds will be installed along the river slope. This would require a cut volume of approximately 1,722 CY and a backfill volume of approximately 6,775 CY (Appendix A provides all related dredging figures and details, including slope and sediment stabilization materials).

Since dredging cannot be conducted in the area of the existing underwater gas, electric, and fiber optic lines that extend across the Hudson River, approximately one acre area near and over the utility crossings will be capped with a cover system consisting of RCM overlain by armored concrete blocks to isolate the impacted sediment in these areas (Figure 4).

3.5 Construction Schedule

Dredging of the contaminated sediments, identified on Figure 3, is anticipated to be conducted between October 2018 and February 2019. Additionally, the less intrusive capping of the underwater utility

crossing areas and the river slope is anticipated to be conducted between July 2019 and September 2019, after the published key migratory spawning season (March 1 through June 30).

4. Federally Listed Species and Designated Critical Habitat

4.1 Aquatic Species

The USFWS has jurisdiction over freshwater fish, amphibians, and freshwater invertebrates. The NMFS has jurisdiction over marine mammals, sea turtles, marine fish and invertebrates.

4.1.1 Marine Mammals

Six marine mammal species listed under the ESA have made rare appearances in the Hudson River or New York City Metropolitan Area segments: five large whale species: the North Atlantic right whale (*Eubalaena glacialis*), humpback whale (*Megaptera novaeangliae*), fin whale (*Balaenoptera physalus*), sei whale (*Balaenoptera borealis*), and sperm whale (*Physeter macrocephalus*); and one sirenian, the West Indian manatee (*Trichechus manatus*). Under the ESA, all whale species fall under the jurisdiction of NMFS, while the West Indian manatee is managed by USFWS. Historic unconfirmed, records of large whales up the Hudson River have been reported as far north as Troy (Kiviat and Hartwig 1994). However, large whales are uncommon in the Hudson River; individual large whales could be found occasionally at the river mouth.

Based on available occurrence records, it is unlikely that ESA-listed marine mammal species would occur in the Hudson River in the vicinity of Poughkeepsie, NY; therefore, the NWS MGP Remediation Project would have no effect on the North Atlantic right whale, humpback whale, fin whale, sei whale, sperm whale, and the West Indian manatee, and those species are not discussed further in this BA.

4.1.2 Marine Reptiles

Four sea turtle species occur seasonally during warmer months (June through mid-November) in the offshore waters of New York Bight (i.e., the bend in the shoreline from the New Jersey coast to Long Island). These are the leatherback (*Dermochelys coriacea*) (endangered), loggerhead (*Caretta caretta*) (threatened), Kemp's ridley (*Lepidochelys kempii*) (endangered), and green (*Chelonia mydas*) (threatened). NMFS and the USFWS share jurisdiction for sea turtles, with NMFS having lead responsibility for the conservation and recovery of sea turtles in the marine environment and USFWS for turtles on nesting beaches.

Based on the lack of upriver sighting records, it is unlikely that any sea turtles would occur in the Hudson River in the vicinity of Poughkeepsie, NY; therefore, the NWS MGP Remediation Project would have no effect on the leatherback, loggerhead, Kemp's ridley, and green sea turtles, and those species are not discussed further in this BA.

4.1.3 Marine Fishes

Under the authority of the ESA, USFWS and NMFS are responsible for the protection and recovery of endangered and threatened fish species. NMFS has jurisdiction over most marine fish and anadromous fish (i.e., fish that are born in fresh water, migrate to the ocean to grow into adults, and then return to

fresh water to spawn) listed under the ESA, while USFWS has jurisdiction over freshwater fish species. The only ESA-listed species that have the potential to occur in the NWS MGP Remediation Project area are the shortnose sturgeon and the Atlantic sturgeon. NMFS has jurisdiction over these fish species that could be affected by the NWS MGP Remediation Project. Details on the life history and occurrence patterns of these species are discussed in the following sections.

Shortnose Sturgeon

The following description of the shortnose sturgeon (*Acipenser brevirostrum*) comes primarily from the following sources, which are incorporated by reference.

- *Recovery Plan for the Shortnose Sturgeon (NMFS 1998)*
- *A Biological Assessment of Shortnose Sturgeon (Acipenser brevirostrum) (SSSRT 2010)*
- *Biological Assessment for the Tappan Zee Hudson River Crossing Project (FHWA 2012)*
- *Biological Opinion for the Tappan Zee Bridge Replacement Project (NMFS 2013a)*
- *Biological Opinion for Continued Operations of Indian Point Nuclear Generating Unit Nos. 2, 5 and 3 (NMFS 2013b).*
- *Revised Biological Assessment for Champlain Hudson Power Express Transmission Line Project (USDOE 2014)*
- GARFO Master ESA Species Table - Shortnose Sturgeon (NMFS Web site https://www.greateratlantic.fisheries.noaa.gov/protected/section7/listing/garfo_master_esa_species_table_-_shortnose_sturgeon_may2017.pdf). Accessed December 8, 2017.

Status. The shortnose sturgeon was listed as endangered in 1967 under the Endangered Species Preservation Act that pre-dated the ESA (32 *Federal Register* 4001). NMFS manages the species and recognizes 19 separate populations of shortnose sturgeon. Individuals occurring in the NWS MGP Remediation Project area belong to the endangered Hudson River population, which is the largest population of shortnose sturgeon, with an estimated 65,000 individuals (USFWS 2009). There is no designated or proposed designated critical habitat for the shortnose sturgeon, so the NWS MGP Remediation Project would have no effect on critical habitat (NOAA 2013, USFWS 2014).

Behavior and Life History. The shortnose sturgeon primarily occurs in freshwater rivers and coastal estuaries. The species is considered freshwater amphidromous, meaning its use of marine waters is limited to the estuaries of its home rivers (Bain 1997). Spawning occurs in upper freshwater areas, while feeding and overwintering activities could occur in both freshwater and saline habitats (NMFS 1998, SSSRT 2010). While the shortnose sturgeon does not undertake the significant marine migrations seen in the Atlantic sturgeon, telemetry data indicate that shortnose sturgeons do make localized coastal migrations. For example, one individual tagged in the Hudson River was recaptured in the Connecticut River (Welsh et al. 2002).

The shortnose sturgeon is a long-lived species (30 to 40 years) that matures at late ages (males attain sexual maturity at 6 to 10 years of age, while females do so between 7 and 13 years) (NMFS 1998). Males

spawn approximately every 2 years, while females spawn every 3 to 5 years. Generally, shortnose sturgeons spawn in gravel- to boulder-sized substrate in April to May. Studies indicate that the spawning period lasts from a few days to several weeks and begins when freshwater temperatures increase from 46 to 48°F (8 to 9 °C), early April through May (NYSDEC 2013a, Dovel et al. 1992). Larvae tend to drift downstream and are generally found between Albany and Poughkeepsie, New York (NatureServe 2017, NYNHP 2010a). Larvae can be found upstream of the saltwater wedge (i.e., a wedge-shaped intrusion of salty ocean water into a tidal river; it slopes downward in the upstream direction, and salinity increases with depth) in the Hudson River estuary and are most commonly found in deep waters with strong currents, typically in the channel (Dovel et al. 1992, Bain 1997). Most activity of larvae, juveniles, and adults appears to occur at night (NatureServe 2017). Juvenile shortnose sturgeons in the Hudson River typically use the same deep channel habitats throughout the tidal reach as adults (Bain 1997).

In northern rivers (e.g., the Hudson River), the shortnose sturgeon feeds in fresh water during summer and over sand-mud bottoms in the lower estuary during fall, winter, and spring (NMFS 1998). Shortnose sturgeons are bottom feeders; their mouths are designed to suck up prey from the river bottom. Juveniles eat available benthic crustaceans and insects. Adults in fresh water feed on mollusks, crustaceans, and insect larvae depending on availability, and, in estuaries, their primary foods are polychaete worms, crustaceans, and mollusks (NatureServe 2017).

Distribution and Habitat. In New York State, the shortnose sturgeon is found in the Hudson River from the Federal Dam at Troy downriver to the southern tip of Manhattan, over a large portion of the fresh and brackish reaches in deep channel habitats (Bain 1997, Bain et al. 2000). All life stages occur in the lower Hudson River. Non-spawners use overwintering habitat concentrated in brackish waters of the lower Hudson River while spawners (in the upcoming spring) overwinter in a single concentration in deep channel habitats further upstream (Bain 1997). Adults migrate upriver from their middle Hudson River overwintering areas to freshwater spawning sites north of Coxsackie, New York when water temperatures reach 46 to 48 °F (8 to 9 °C) (NYSDEC 2013a, Dovel et al. 1992).

Shortnose sturgeon have been found in waters with temperatures as low as 36 to 37 °F (2 to 3 °C) and as high as 93 °F (34 °C) (Dadswell et al. 1984). Water temperatures above 82 °F (28 °C) are thought to adversely affect shortnose sturgeon. Shortnose sturgeon are known to occur at depths of up to 98 feet (30 meters) but are generally found in waters less than 66 feet (20 meters) (Dadswell et al. 1984). Adults occur in both freshwater and upper tidal saline areas all year. Juveniles (age of 3 to 10 years) generally occur at the saltwater/freshwater interface (i.e., salt front) (Dovel et al. 1992).

Spawning grounds extend from below the Federal Dam at Troy downriver to around Coeymans, New York (Dovel et al. 1992). Spawning typically occurs at water temperatures between 50 and 64 °F (10 and 18 °C) (generally early April through May). Shortnose sturgeon eggs are expected to hatch in 8 to 13 days and embryos gradually disperse downstream over much of the Hudson River estuary. Shortnose sturgeon larvae captured in the Hudson River were associated with deep waters and strong currents (Hoff et al. 1988 as cited in Bain 1997). Juvenile shortnose sturgeon are predominantly found in deep channels in mid-river region in the mid-summer (Hoff et al. 1998 and Pekovitch 1979 as cited in Bain 1997). After spawning, adults disperse quickly down river into their summer range. The broad summer range occupied by adult shortnose sturgeon extends from just south of Catskill, New York, downriver to the Palisades area near the border of New York and New Jersey. Similar to non-spawning adults, most juveniles occupy

the broad region of Haverstraw Bay by late fall and early winter (Dovel et al. 1992). Migrations from the summer foraging areas to the overwintering grounds are triggered when water temperatures fall below approximately 46 °F (8 °C), which typically occurs in late November (NMFS 1998). Juveniles are distributed throughout the mid-river region during the summer and move back into the Haverstraw Bay region during the late fall.

From late fall to early spring, adult shortnose sturgeon concentrate in a few overwintering areas. Reproductive activity the following spring determines overwintering behavior. The largest overwintering area is just south of Kingston, New York, near Esopus Meadows (Dovel et al. 1992). The fish overwintering at Esopus Meadows are mainly spawning adults. Captures of shortnose sturgeon during the fall and winter from Saugerties to Hyde Park (greater Kingston reach), indicate that additional smaller overwintering areas may be present (Geoghegan et al. 1992). An overwintering site in the Croton-Haverstraw Bay area has also been confirmed (Geoghegan et al. 1992, Dovel et al. 1992). Fish overwintering in areas below Esopus Meadows are mainly thought to be pre-spawning adults. Typically, movements during overwintering periods are localized and fairly sedentary. The shortnose sturgeon prefers deep channel habitats during the winter season.

Shortnose sturgeon eggs and larvae are limited to the low salinity waters near spawning grounds, and young of the year are also restricted to areas of low salinity. The shortnose sturgeon spawning grounds in the Hudson River are greater than 125 miles [48 km] upstream from the Harlem and East rivers.

The Greater Atlantic Regional Fisheries Office (GARFO) of the NMFS has prepared information on the use of the watersheds where shortnose sturgeon are found; this information is available on their Web site and is presented in Table 1 below.

Threats. Throughout the shortnose sturgeon's range, habitat degradation or loss (resulting, for example, from dams, bridge construction, channel dredging, and pollutant discharges) and mortality (resulting, for example, from impingement on cooling water intake screens, dredging and incidental capture in other fisheries) are the principal threats to survival (NMFS 1998).

Atlantic Sturgeon

The following description of the Atlantic sturgeon (*Acipenser oxyrinchus oxyrinchus*) comes primarily from the following sources, which are incorporated by reference.

- *Status Review of Atlantic Sturgeon (Acipenser oxyrinchus oxyrinchus) (ASSRT 2007)*
- *Biological Assessment for the Tappan Zee Hudson River Crossing Project (FHWA 2012)*
- *Biological Opinion for the Tappan Zee Bridge Replacement Project (NMFS 2013a)*
- *Biological Opinion for Continued Operations of Indian Point Nuclear Generating Unit Nos. 2 and 3 (NMFS 2013b).*
- *Revised Biological Assessment for Champlain Hudson Power Express Transmission Line Project (USDOE 2014)*
- GARFO Master ESA Species Table – Atlantic Sturgeon (NMFS Web site https://www.greateratlantic.fisheries.noaa.gov/protected/section7/listing/garfo_master_esa_species_table_-_atlantic_sturgeon_051917.pdf). Accessed December 8, 2017

Table 1 GARFO Master ESA Species Table - Shortnose Sturgeon

Body of Water	Distribution/Range in Watershed	Life Stages Present	Use of the Watershed	References
Hudson River	up to the Troy Dam (approximately river kilometer (RKM) 246)	eggs, larvae, YOY, juveniles, subadults, and adults	<p>Spawning - Documented from late March to early May when water temperatures reach 10°-18°C[1] from Coxsackie to below the Federal Dam at Troy[1][3] (RKM 190-246) Rearing - Eggs on the spawning grounds; larvae downstream to at least RKM 104; YOY downstream to at least RKM 64[1] Foraging - Throughout the Hudson River[3] (RKM 38-166) with concentrations in Haverstraw Bay[1] (RKM 56-64) Overwintering - Late fall to early spring[3]; largest area (mainly spawning adults) near Kingston[2] (RKM 137-149); smaller overwintering areas are located from Saugerties to Hyde Park[2] (RKM 123-170) and in the Croton-Haverstraw Bay area[2] (RKM 54-61); many juveniles overwinter in the lower river[1] (RKM 0-64)</p>	Dovel and Berggren 1983; Coch 1986; Van Eenennaam et al. 1996; Bain 1997; Kahnle et al. 1998; Bain et al. 1998, 2000; Savoy and Pacileo 2003; Sweka et al. 2006; ASSRT 2007; Normandeau Associates, Inc. 2014

Status. The Atlantic sturgeon is not listed as threatened or endangered, there are five DPSs that are listed: threatened Gulf of Maine DPS, endangered New York Bight DPS, endangered Chesapeake Bay DPS, endangered Carolina DPS, and South Atlantic DPS. Individuals from any of these five DPSs could occur in the NWS MGP Remediation Project area (Colligan 2012). Based on genetic sampling of Atlantic sturgeon captured within the Hudson River, three DPSs are most likely to occur in the Hudson River (ranked largest to smallest): New York Bight DPS, Gulf of Maine DPS, and Chesapeake Bay DPS (NMFS 2013b, 77 *Federal Register* 5880). Based on the previously mentioned genetic sampling, the majority of Atlantic sturgeon in the Hudson River are likely to be of the New York Bight DPS. In the New York Bight DPS, there are two known spawning populations: those in the Hudson and Delaware rivers. Currently, the existing spawning population in the Hudson River is estimated to have 870 adults spawning each year (600 males and 270 females), and there is no indication that the population is increasing (77 *Federal Register* 5880).

On August 17, 2017, critical habitat was designated for the Endangered New York Bight, Chesapeake Bay, Carolina and South Atlantic Distinct Population Segments of Atlantic Sturgeon and the Threatened Gulf of Maine Distinct Population Segment of Atlantic Sturgeon (82 *Federal Register* 39160). This Final Rule became effective September 18, 2017. Critical habitat has been designated for the Atlantic sturgeon in the Hudson River from the southern end of Manhattan, NY to the Troy Lock and Dam in Rensselaer County, NY.

Section 4(b)(8) of the ESA identifies those activities that may destroy or adversely modify such habitat or that may be affected by such designation. A wide variety of activities may affect critical habitat and, when carried out, funded, or authorized by a Federal agency, will require an ESA section 7 consultation because they may affect one or more of the PBFs of critical habitat; such activities include dredging.

In December 2017, sampling to identify benthic invertebrates was conducted in the project area. Benthic samples were obtained through the use of a Van Veen Grab sampler. The grab collected to collect sediments from the Hudson River bottom. The grab sample was then brought to the surface and the sediments were washed away over a screen table. The remaining contents were then placed in a container with a preservative and biological stain. Later, the remaining materials were examined with a microscope and all species were identified to the lowest possible taxon. Nine mid-stream, three shoreline and two reference locations¹ were sampled (Figure 5).

As can be observed in Table 2 below, a typical assemblage of Hudson River benthic invertebrates were observed in both the dredge prism areas and the reference locations. Due to composition substrate along the shoreline, two of the three shoreline sites were unable to produce fine-grained sediment samples, and at the one that collected a sample only zebra mussels and one blue mussel shell was observed. The zebra mussel, an invasive species, was observed at several locations. Blue mussel shell fragment were observed at several sample locations, but only the two reference sites and Location 27 samples yielded any live species. Some amphipods were observed at most sites but were not observed at either of the reference sites. Other species observed in small quantities at some sites include isopods, clams, midge larvae, American eel, and snails, although often samples contained only fragments rather than live specimen. Many of the samples exhibited a strong odor or sheen, likely as a result of historic contamination.

¹ Reference Locations 1 was located approximately 2,500 feet north of Dutchess Avenue off the eastern shoreline. N 41.718205, W -73.939893
Reference Location 2 was located approximately 2,900 feet northwest of Dutchess Avenue off the western shoreline. N 41.716921, W-73.948095

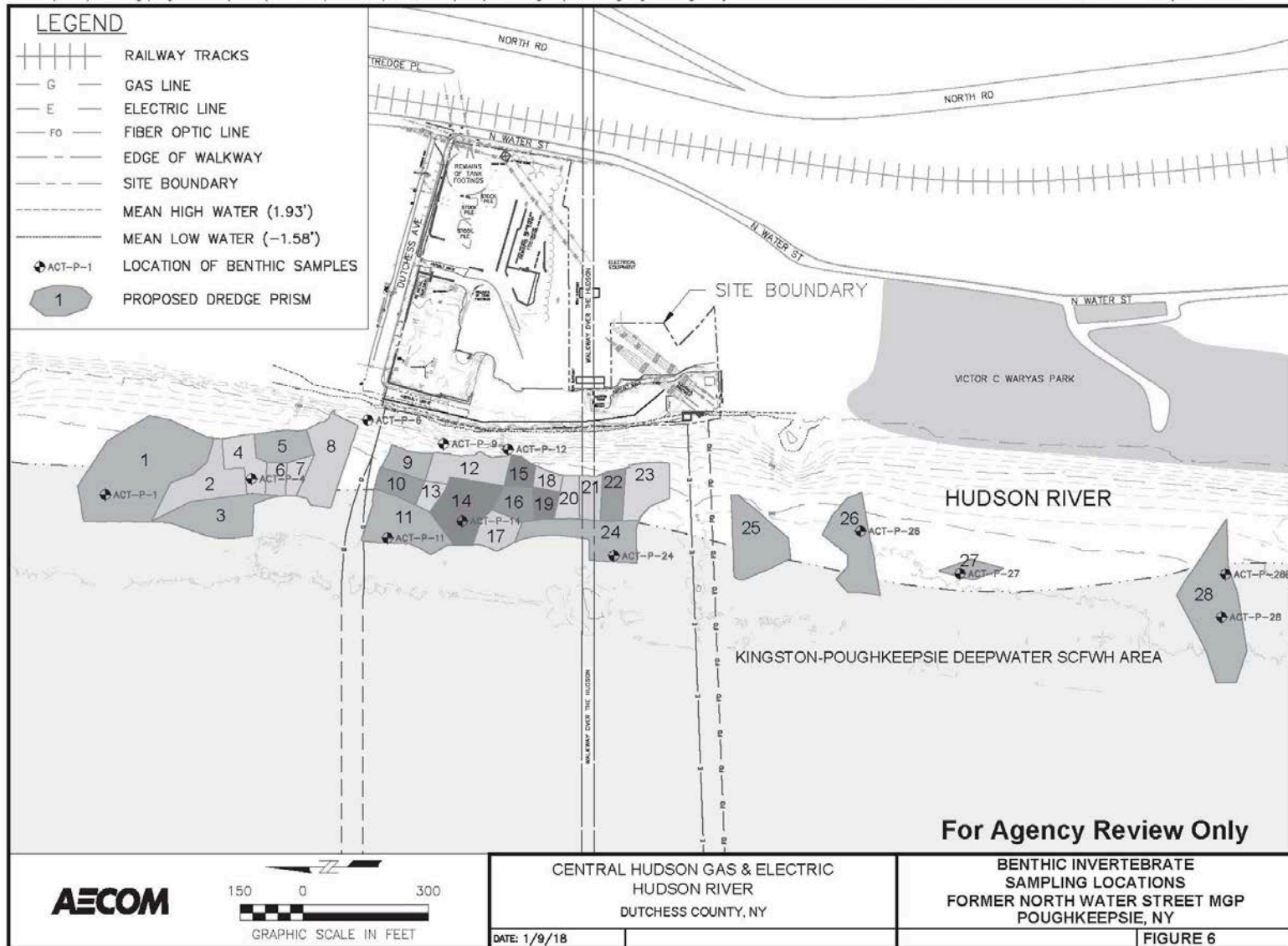

Figure 6 Benthic Invertebrate Sample Locations

Table 2
Benthic Invertebrates – Project Area

Site ^a	Depth ^b (feet below surface)	Substrate Composition	Zebra mussel ^c (<i>Dreissena polymorpha</i>)	Amphipod (<i>Gammaridea</i> sp.)	Slender Isopod (<i>Cyathura</i> sp.)	Asian clam (<i>Corbicula</i> sp.)	Midge larvae (<i>Chironomidae</i> sp.)	Blue mussel (<i>Mytilus edulis</i>)	American eel (<i>Anguilla rostrata</i>)	Insecta sp.	Bivalve sp.	Faucet snail (<i>Bithynia tentaculata</i>)	Gastropod sp.	Other
ACT-P-1	54	Silt, some coarse sand and leaf litter.	20	1										Woody detritus, some black grit, few pieces of gravel. 1 hogchocker flounder.
ACT-P-4	55	Silt, some coarse sand and leaf litter.	10	5				1 SF						Woody detritus with some leaves. Sheen and odor of MGP product.
ACT-P-11	60	Silt.	25											Woody detritus with some black grit. Sheen and odor.
ACT-P-14	53	Silt, some coarse sand.	15	4		1	2		1					Woody detritus with some tar blobs. Some sheen.
ACT-P-24	56	Silt, some gravel, some coarse sand, shells, rock and brick fragments.	205	3				1 SF						Some gravel with slag, coarse sand and black grit. Strong odor.
ACT-P-26	53	Silt, some gravel and coarse sand.	23			2	1				1 SF			Some gravel, coarse sand and black grit. Woody detritus, gravel and slag. Sheen and odor.

Site ^a	Depth ^b (feet below surface)	Substrate Composition	Zebra mussel ^c (<i>Dreissena polymorpha</i>)	Amphipod (<i>Gammaridea</i> sp.)	Slender Isopod (<i>Cyathura</i> sp.)	Asian clam (<i>Corbicula</i> sp.)	Midge larvae (<i>Chironomidae</i> sp.)	Blue mussel (<i>Mytilus edulis</i>)	American eel (<i>Anguilla rostrata</i>)	Insecta sp.	Bivalve sp.	Faucet snail (<i>Bithynia tentaculata</i>)	Gastropod sp.	Other
ACT-P-27	58	Silt, some shells.	210					4 live, 3 SF						Gravel, slag, some black grit. Sheen and odor of free product.
ACT-P-28	52	Silt, some shells.	126	2		3 SH	2	1 SF	1	1 WF				Woody detritus with some coarse sand, black grit and shell fragments.
ACT-P-28B	55	Silt, some shells.	300	7	1			6 SF						Gravel, some slag, coarse sand and grit.
ACT-P-12	25	Refusal, no sample collected. 1 large stone encrusted with zebra mussels.												No sample collected.
ACT-P-9	30	Refusal, no sample collected.												No sample collected.
ACT-P-6	20	Silt, some coarse sand and gravel.	25					1 SF				1		Rocks, gravel, slag, coarse sand, and black grit, some woody detritus.
Reference 1	51	Silt, some shells.	21			1	1	1 live, 2 SF						Gravel with coal, slag, coarse sand, black grit, and woody detritus. Some sheen.
Reference 2	35	Silt.	300					1 live				1	1 EF	Woody detritus with some black grit, gravel, sticks, slag, and coarse sand.

Notes: Three samples were collected at each site location. Results show the aggregate of the three samples.

- a. Indicates the average depth of the three samples.
- b. Zebra mussel counts include shells and fragments.
- c. SF = Shell Fragment; SH = Shell; WF = Wing Fragment; Eroded/Fossilized Shell

Also, within the dredge prisms, some of the benthic habitat would be considered impaired as it contains NAPL or other debris materials. This may contribute to the lack of abundance or diversity in many of the samples, including nearby reference samples.

Behavior and Life History. Atlantic sturgeon are long-lived (approximately 60 years), late-maturing, estuarine-dependent, anadromous fish (i.e., adults spawn in fresh water in the spring and early summer and migrate into estuarine and marine waters where they spend most of their lives). In the Hudson River, the Atlantic sturgeon matures at 11 to 21 years (ASSRT 2007). Males spawn approximately every 1 to 5 years and females every 2 to 5 years.

Eggs are deposited on hard-bottom substrate (e.g., cobble, coarse sand, and bedrock) (Greene et al. 2009). After hatching, larval fish move downstream at night and seek refuge during the day. As larval fish make their way downstream, they grow and become more tolerant of brackish and saline waters, and eventually reside entirely in estuarine waters (for 2 to 6 years) until they reach sub-adulthood and move into the open ocean (Bain 1997). Locations of sonic-tagged juvenile sturgeons revealed that individuals are found most often in dynamic mud habitat (ASMFC 2008). When juveniles begin to emigrate they travel widely along the Atlantic Coast and its estuaries.

Atlantic sturgeons are bottom-feeders that suck food into their mouths. Diets of adult and migrant sub-adult Atlantic sturgeon include mollusks, gastropods, amphipods, annelids, decapods, isopods, and fish (e.g., sand lance). Juvenile Atlantic sturgeon feed on aquatic insects, insect larvae, and small invertebrates (ASSRT 2007). Adults feed primarily on benthic worms (e.g., polychaetes), crustaceans, and mollusks (NOAA 2013).

Distribution and Habitat. Spawning generally occurs between May and July in the Hudson River (Bain 1997, Bain et al. 2000). Male sturgeons begin upstream spawning migrations when waters reach approximately 43 °F (6 °C), and remain on the spawning grounds throughout the spawning season. Females begin spawning migrations when temperatures are warmer at 54 to 55 °F (12 to 13 °C), make rapid spawning migrations upstream, and quickly depart following spawning (Greene et al. 2009).

Spawning likely occurs in multiple sites within the Hudson River in the vicinity of the NWS MGP Remediation Project from RMs 254 to 269 (Dovel and Berggren 1983, Van Eenennaam et al. 1996, Kahnle et al. 1998, Bain et al. 2000). Spawning sites in a given year can be influenced by the position of the salt wedge (where the salt water from the estuary meets the fresh water of the river) (Dovel and Berggren, 1983, Van Eenennaam et al. 1996, Kahnle et al. 1998). The area around Hyde Park (RM 254) has consistently been identified as a spawning area through scientific studies and historical records of the Hudson River sturgeon fishery. Habitat conditions near Hyde Park site are fresh water year-round with bedrock, silt, and clay substrates and water depths of 40 to 80 feet (12 to 24 meters) (Dovel and Berggren 1983, Van Eenennaam et al. 1996, Kahnle et al. 1998, Bain et al. 2000). A spawning site near New Hamburg near RM 266 has also been identified based on tracking data; has clay, silt, and sand substrates; and is approximately 70 to 90 feet (21 to 27 meters) deep (Bain et al. 2000, NMFS 2014). Larvae are expected to occur from June through August in the vicinity of the spawning area (Bain et al. 2000).

Juvenile Atlantic sturgeon have been recorded in the Hudson River between approximate RMs 245 (near Kingston, New York) and 295 (north of Haverstraw Bay), which includes some brackish waters; however, larvae must remain upstream of the salt wedge because of their low salinity tolerance (Dovel and Berggren 1983, Kahnle et al. 1998, Bain et al. 2000). Catches of immature sturgeon (age 1 and older) suggest that juveniles use the estuary from Kingston to the Tappan Zee Bridge (RMs 245 to 310).

Seasonal movements are apparent with juveniles occupying waters from RMs 270 to 295 during summer months and then moving downstream as water temperatures decline in the fall, primarily occupying waters in the vicinity of the NWS MGP Remediation Project from RMs 290 to 324 (Dovel and Berggren 1983, Bain et al. 2000). Based on river-bottom sediment maps (Coch 1986), most juvenile sturgeon habitats in the Hudson River have clay, sand, and silt substrates (Bain et al. 2000). Newburgh and Haverstraw Bays in the Hudson River are areas of known juvenile sturgeon concentrations. Sampling in spring and fall revealed that highest catches of juvenile Atlantic sturgeon occurred during the spring in soft-deep areas of Haverstraw Bay, even though this habitat type composed only 2 percent of the available habitat in the bay. Overall, 90 percent of the total 562 individual juvenile Atlantic sturgeon captured during the course of this study came from Haverstraw Bay (Sweka et al. 2007). At around 3 years of age, Hudson River juveniles exceeding 28 inches (70 cm) in length begin to migrate to marine waters (Bain et al. 2000, NMFS 2014). It has also been reported that older juveniles and post-spawn adult sturgeon congregate in deepwater habitat during the summer in the Hudson River (Bain et al. 2000). Sonic-tagged spawning adults were detected in the river as early as April and as late as October (ASMFC 2008).

After emigration from the natal estuary, sub-adults and adults travel within the marine environment, typically in waters less than 164 feet (50 meters) in depth, using coastal bays, sounds, and ocean waters. Satellite-tagged adult sturgeon from the Hudson River concentrate in the southern part of the Mid-Atlantic Bight at depths greater than 66 feet (20 meters) during winter and spring, and in the northern portion of the Mid-Atlantic Bight at depths less than 66 feet (20 meters) in summer and fall (Erickson et al. 2011). Atlantic sturgeon adults and sub-adults that are not spawning live in coastal and estuarine conditions, generally in shallow water (33 to 164 feet [10 to 50 meters]) in nearshore areas dominated by gravel and sand (Greene et al. 2009).

The Greater Atlantic Regional Fisheries Office (GARFO) of the NMFS has prepared information on the use of the watersheds where Atlantic sturgeon are found; this information is available on their Web site and is presented in Table 3 below.

Threats. Unintended catches of Atlantic sturgeon in fisheries, vessel strikes, poor water quality, water availability, dams, lack of regulatory mechanisms for protecting the fish, and dredging are the most significant threats to Atlantic sturgeon (77 *Federal Register* 5880, 77 *Federal Register* 5914).

Table 3

GARFO Master ESA Species Table - Atlantic Sturgeon

Body of Water	Distribution/Range in Watershed	Life Stages Present	Use of the Watershed	References
Hudson River	up to the Troy Dam (approximately RKM 246)	eggs, larvae, YOY, juveniles, subadults, and adults	<p>Spawning - late spring to summer around Hyde Park (RKM 134), Catskill (RKM 182), and around RKM 112; evidence strongly suggests that there is also spawning further upstream of RKM 193</p> <p>Rearing - eggs - RKM 60-148; larvae - summer; remain upstream of the salt wedge; vicinity of spawning area; YOY: between RKM 60-148; juveniles - spring through fall in RKM 68-107; utilize the estuary from the Tappan Zee Bridge through Kingston (RKM 43-148); occupy waters from RKM 37-66 during the summer; Newburgh and Haverstraw Bays (RKM 55- 61) are areas of known juvenile concentrations</p> <p>Foraging - tidally influenced flats; may be using the lower Hudson River for foraging in the summer</p> <p>Overwintering - may be using the lower Hudson River from winter; juveniles - RKM 19-74 from fall through winter</p>	<p>Dovel and Berggren 1983; Coch 1986; Van Eenennaam et al. 1996; Bain 1997; Kahnle et al. 1998; Bain et al. 1998, 2000; Savoy and Pacileo 2003; Sweka et al. 2006; ASSRT 2007; Normandeau Associates, Inc. 2014</p>

4.1.4 Aquatic Invertebrates

The dwarf wedgemussel (*Alasmidonta heterodon*) is an ESA endangered freshwater mollusk species that occurs in New York State. Its extent is limited to a small area within the upper Delaware River watershed in Sullivan and Delaware counties, and in one of its major downstream tributaries, the lower Neversink River in Orange County (NatureServe 2017, NYSDEC 2013b). Since the dwarf wedgemussel does not occur in the NWS MGP Remediation Project area, the NWS MGP Remediation Project would have no effect on this species.

4.2 Terrestrial Species

Under the authority of the ESA, USFWS is responsible for the protection and recovery of endangered and threatened terrestrial species. The terrestrial species that are federally listed, or are proposed for Federal listing, that have previously been identified in the vicinity of the NWS MGP Remediation Project area are identified in the letter from the USFWS dated November 7, 2017 and discussed below.

Indiana Bat

Status. The Indiana bat (*Myotis sodalists*) was officially listed as an endangered species on March 11, 1967 (32 *Federal Register* 4001). Critical habitat was designated for the species on September 24, 1976 (41 *Federal Register* 14914). Thirteen hibernacula, including eleven caves and two mines in six states, were listed as critical habitat; however, there is no designated or proposed designated critical habitat for this species in New York State. The following description of the Indiana bat comes primarily from the following sources, which are incorporated by reference.

- *Indiana Bat Recovery Plan (USFWS 1983)*
- *Revised Draft Recovery Plan for the Indiana Bat (USFWS 2007)*
- *Indiana Bat Five-Year Review (USFWS 2009)*
- *Biological Assessment, Indiana Bat (Myotis sodalists), St. Lawrence Windpower Project, Jefferson County, New York (Young et al. 2010)*
- *Revised Biological Assessment for Champlain Hudson Power Express Transmission Line Project (USDOE 2014)*

Behavior and Life History. The Indiana bat is a temperate, insectivorous, migratory bat that hibernates in caves and mines in the winter (typically October through April) and summers in wooded areas. It is a medium-sized bat 1.5 to 2 inches long, having a wingspan of 9 to 11 inches (23 to 28 cm), and weighing approximately only one-quarter of an ounce. It has brown to dark-brown fur and the facial area often has a pinkish appearance. The Indiana bat feeds primarily on aquatic and terrestrial insects. Diet varies seasonally and variations exist amongst different ages, sex, and reproductive status (USFWS 1999). Indiana bats forage in closed to semi-open forested habitats and forest edges located in floodplains, riparian areas, lowlands, and uplands.

In Illinois, Gardner et al. (1991) found that forested stream corridors, and impounded bodies of water, were preferred foraging habitats for pregnant and lactating Indiana bats, which flew up to 1.5 miles (2.4

km) from upland roosts to forage. They forage between dusk and dawn and feed exclusively on flying insects, primarily moths, beetles, and aquatic insects. Riparian habitat is occupied by Indiana bats from mid-April to mid-September. Romme et al. (1995) cite several studies which document that Indiana bats also forage in upland forests.

Distribution and Habitat. During winter, Indiana bats are restricted to suitable underground habitats known as hibernacula. The majority of hibernacula consist of limestone caves, but abandoned underground mines, railroad tunnels, and even hydroelectric dams can provide winter habitat throughout the species' range (USFWS 2007). Hibernacula with stable or growing populations of Indiana bats have stable low temperatures that allow the bats to maintain a low rate of metabolism and conserve fat reserves through the winter.

Spring emergence occurs when outside temperatures have increased and insects (forage) are more abundant (Richter et al. 1993). Female Indiana bats emerge from hibernation in late March or early April, followed by the males. The period after hibernation but prior to migration is typically referred to as staging. Spring staging occurs when some bats remain close to the cave for a few days before migrating to summer habitats. Others head directly to summer habitat. Most populations leave their hibernacula by late April.

Potential summer habitat occurs throughout much of New York State. At least 39 documented maternity colonies have been identified in Cayuga, Columbia, Dutchess, Essex, Jefferson, Onondaga, Orange, Oswego, and Ulster counties. Male bats disperse throughout the range and roost individually or in small groups. In contrast, reproductive females form larger groups, referred to as maternity colonies, in which they raise their offspring. Non-reproductive females roost individually or in small groups and occasionally are found roosting with reproductive females. Summering Indiana bats (males and females) roost in trees in riparian, bottomland, and upland forests.

Roost trees generally have exfoliating bark which allows the bat to roost between the bark and bole of the tree. Cavities and crevices in trees also may be used for roosting. A variety of tree species are used for roosts including, but not limited to, silver maple (*Acer saccharinum*), sugar maple (*Acer saccharum*), shagbark hickory (*Carya ovata*), shellbark hickory (*Carya laciniosa*), bitternut hickory (*Carya cordiformis*), green ash (*Fraxinus pennsylvanica*), white ash (*Fraxinus americana*), eastern cottonwood (*Populus deltoides*), northern red oak (*Quercus rubra*), post oak (*Quercus stellata*), white oak (*Quercus alba*), shingle oak (*Quercus imbricaria*), slippery elm (*Ulmus rubra*), American elm (*Ulmus americana*), and sassafras (*Sassafras albidum*) (Romme et al. 1995). Structure is probably more important than the species in determining if a tree is a suitable roost site. Tree species which develop loose, exfoliating bark as they age and die are likely to provide roost sites. Exposure of trees to sunlight and location relative to other trees are important to suitability (USFWS 1999).

During the fall breeding season, female bats can number from 50 to 100 individuals in a single tree (NYSDEC 2012b). Maternity colonies use a minimum of 8 to 25 trees per season (Callahan et al. 1997, Kurta et al. 2002). On the average, Indiana bats typically switch roosts every 2 to 3 days with reproductive condition of the female, roost type, weather conditions, and time of year affecting switching behavior (Kurta et al. 2002, Kurta 2005).

Very little research has focused on the use of travel corridors by Indiana bats. Most information pertaining to bat movements and travel corridors is incidental to other portions of a study and general observations. However, Murray and Kurta (2004) showed that Indiana bats increased commuting distance by 55 percent to follow tree-lined paths rather than flying over large agricultural fields, some of which were at least 0.6 miles (1 km) wide. Apparently, suitable forest patches might not be available to Indiana bats unless they are connected by a wooded corridor; however, we do not know the maximum size of an opening Indiana bats can cross. There are numerous observations of Indiana bats crossing interstate highways and open fields. In New York State, Indiana bats tracked from hibernacula to spring and summer roosts have crossed I-81, the Hudson River, I-87, and other highways. These crossings primarily occurred during the initial migration from hibernacula to spring and summer habitats, rather than during nightly foraging bouts.

While little is known about behavior during dispersal, evidence from radio-tracking studies in New York and Pennsylvania indicate that Indiana bats are capable of dispersing at least 30 to 40 miles (48 to 64 km) in one night (Young et al. 2010). It appears as if Indiana bat dispersal from hibernacula to summer habitat is fairly linear and short-term but in the fall is more dispersed and varied. Some studies have shown that Indiana bats travel between 9 and 17 miles (15 and 27 km) from a roost site to a hibernaculum cave where swarming is occurring. In addition, males and females display different dispersal behavior. Females appear to move quickly between the hibernacula and maternal colonies, while males will commonly remain near the hibernacula. While it is unknown, it is likely that Indiana bats dispersing to and from hibernacula follow more meandering routes that may be habitat-related and do not fly at high altitudes, in highly linear paths, or long distances (more than 50 miles [80 km]) non-stop (USFWS 2007).

Threats. The primary threats to Indiana bats in New York State are White-nose Syndrome (WNS), energy development (e.g., wind power), and residential and commercial development that fail to incorporate measures to maintain suitable Indiana bat habitat, and avoid and minimize impacts on maternity colonies and swarming bat populations. Over the long term, from 1965 to 2001, there has been an overall decline in Indiana bat populations and winter habitat modifications have been linked to changes in populations at some of the most important hibernacula. Summer habitat modification is also suspected to have contributed to the decline of bat populations; however, it is difficult to generalize how forest management or disturbance may affect Indiana bats. The *Indiana Bat Draft Recovery Plan* (USFWS 2007) provides a comprehensive summary of Indiana bat life history, which is incorporated by reference.

Northern Long-Eared Bat

Status. In an effort to conserve the northern long-eared bat (*Myotis septentrionalis*), the U.S. Fish and Wildlife Service issued a final rule on January 14, 2016 (81 *Federal Register* 1900) that uses flexibilities under section 4(d) of ESA to tailor protections to areas affected by white-nose syndrome during the bat's most sensitive life stages. The Service listed the northern long-eared bat as threatened under the ESA in April 2015 and established an interim 4(d) rule following drastic population declines caused by white-nose syndrome in the eastern and mid-western United States. The final 4(d) rule for the northern long-eared bat removes prohibitions that would otherwise be in place on "incidental take" of the bat in areas of

the country not affected by white-nose syndrome. There is no designated or proposed critical habitat for this species in New York State. The following description of the northern long-eared bat comes primarily from the following sources, which are incorporated by reference.

- *Revised Biological Assessment for Champlain Hudson Power Express Transmission Line Project (USDOE 2014)*
- *Protections Finalized for Threatened Northern Long-Eared Bats (USFWS 2016)*
- *Programmatic Biological Assessment for Transportation Projects in the Range of the Indiana Bat and Northern Long-Eared Bat (FHWA 2016)*

Behavior and Life History. The northern long-eared bat is medium-sized, averaging between 3 and 3.7 inches (7.62 and 9.4 cm) in length with a wingspan that measures between 9 and 10 inches (23 and 26 cm) (Caceres and Barclay 2000). Females of this species are generally larger and heavier than the males (Caceres and Pybus 1997). As its name suggests, this bat is distinguishable from other *Myotis* species by long ears that extend beyond the tip of its nose when laid forward, a long, narrow, and sharp pointed tragus, and a calcar (cartilage spur at ankle) that lacks a keel (Caceres and Barclay 2000, USFWS 2013b). This species has medium to dark brown fur on its back, dark brown ears and wing membranes.

The diet for the northern long-eared bat is diverse and varied according to season and geographical occurrence. Generally, the diet will consist of moths, flies, leafhoppers, beetles and caddisflies, and spiders. Bats will catch insects by hawking (catching in flight) and gleaning (emitting a high-frequency echolocation call) to find prey (Henderson and Broders 2008). The gleaning call of the northern long-eared bat is the highest frequency of any bat species, and is higher than the hearing frequency of many moth species, thereby giving it a foraging advantage within its feeding habitat. Breeding for this species begins in late summer or early fall when males begin swarming near hibernacula. Following fertilization, pregnant females migrate to summer areas where they roost in small colonies of between 30 and 60 bats, although larger maternity colonies have been observed. Like the Indiana bat, the female northern long-eared bat will nest under the loose dead bark of trees such as shagbark hickory. There is also documentation of this species roosting in manmade structures such as buildings and barns. Females in a maternity colony generally give birth to one pup, and will all give birth at around the same time of year, from late May to late July, depending on where the colony is located within its home range. Young bats begin to fly and explore approximately 4 weeks following birth. Adult northern long-eared bats live up to 19 years (USFWS 2013b).

Distribution and Habitat. The range of this species includes much of the eastern and north central United States, and all Canadian provinces for the Atlantic Ocean west to the southern Yukon Territory and eastern British Columbia (USFWS 2013b). This species has been observed year-round throughout New York State (USFWS 2013f).

Habitat use changes over the course of the year and varies based on sex and reproductive status. Reproductive females often use different summer habitat than males and non-reproductive females. Generally, summer and winter ranges for this species will be identical, but the habitat types used within those ranges will differ. Potential summer habitat occurs throughout much of New York State. Maternity colonies are formed in roost trees and are more widely distributed and numerous than are major

hibernacula. Northern long-eared bats overwinter in multi-species hibernacula that are typically caves or abandoned underground mine shafts with deep crevices (Caceres and Pybus 1997, Caceres and Barclay 2000). In these hibernacula, this species will usually comprise less than 25 percent of the total number of individuals (Caceres and Pybus 1997). Northern long-eared bats have been observed in 58 hibernacula in mines, caves, and tunnels in New York.

Edge habitat is important for northern long-eared bats as they migrate and forage (WDNR 2013). Bats will migrate from hibernacula to summer roosts, or fly from their roosts to feeding grounds following the habitat edges to maintain protection from wind and predation. Additional to the protection that edge habitat provides, this behavior may also allow bats more feeding opportunities because food is more abundant around edge habitat. Commuting along edge habitat may assist the bats with navigation and orientation through use of linear edges as landmarks.

Threats. Most mortality in this species occurs during the juvenile stage (Cyceres and Pybus 1997). The predominant threat affecting population declines of this species is WNS, an emerging infectious fungal disease that depletes fat stores, reduces responsiveness to human disturbance, and results in a lack of immune response during hibernation and uncharacteristic dispersing from hibernacula during the day in mid-winter (WNS Session 2008). As indicated for the Indiana bat, northern long-eared bat populations are declining with the destruction and modification of their summer and winter habitats. Access to hibernacula may be restricted by doors or gates intended to exclude humans. Also, the thermal regime typical of these habitats may be adversely altered by mining activities, or hibernacula in mines may be destroyed altogether with mine passage collapses. Additionally, habitats are subject to adverse impacts from development activities (industrial, commercial, and residential) on overwintering, roosting, and feeding bats.

In December 2017, a site investigation was performed by an ecologist who is also a certified arborist. Based on the results of the investigation, it was identified that no trees along the shoreline or within the area of disturbance had the potential to serve as bat roosting habitat. It was observed that in close proximity to the site, there are large swathes of woodlands and within the site, there are abandoned concrete structures and voids, which would not be disturbed as part of the dredging, that would likely serve as attractive bat roosting habitat.

Peregrine Falcon

Status. As indicated in the letter from the New York Natural Heritage Program dated November 21, 2017, the peregrine falcon (*Falco peregrinus*) is listed as endangered in New York State; it is not listed as endangered or threatened in the ESA. The following description of the peregrine falcon comes primarily from the following sources, which are incorporated by reference.

- *Peregrine Falcon Fact Sheet* (NYSDEC 2017)
- *Falcons Nesting on the Mid-Hudson Bridge* (NYSBA 2017)

Behavior and Life History. Peregrine falcons generally return to the same nesting territory annually and mate for life. The courtship flight is a spectacular sight. The pair climbs high in the air and performs a

precise acrobatic act of whirling spirals and steep rapid dives, often touching in midair. The average clutch consists of three to four eggs which hatch after an incubation period of 29-32 days. The single brood fledges after 35-42 days. Both parents participate in incubation and brooding activities, but the female remains at the nest for the majority of the time while the male hunts and brings food to her and the young. Young falcons may stay in the area for about six weeks after they fledge, developing their flying and hunting skills. Sexual maturity is generally reached at two years of age, but one-year-olds have been known to produce young. Individuals may live as long as 20 years.

Behavior and Distribution: At one time, there were approximately 350 breeding pairs in the eastern U. S., including 40-50 historic eyries (nest sites) in New York. By 1965, all were gone and populations in other parts of the country showed similar declines. Release programs initiated by the Peregrine Fund in the mid 1970's have resulted in peregrine falcons breeding in New York once again. In 1998, 38 pairs were present in New York, 36 bred, 31 were successful and 69 young fledged. New urban nests have been reported upstate for the first time in Albany. Gradual increases in the breeding population have been recorded throughout the east.

Peregrine falcons nest in a nest box on the Mid-Hudson Bridge, which carries State Routes 44 and 55 over the Hudson River, between Poughkeepsie and Highland, NY. The bridge is about 0.5 miles south of the site. The first nest box on the Mid-Hudson Bridge was put up in the late 80's by "Project Soar" through a program sponsored by the Museum of the Hudson Highlands. However, it was not until 1996 that peregrine falcons nested on the Mid-Hudson Bridge. Since then, falcons have nested on the Mid-Hudson Bridge every year, except 2001.

Threats. Like many other birds of prey, peregrine falcons have suffered from the use of pesticides. Exposure to DDT and other chemical contaminants has caused population declines since the 1940's. These pesticides cause eggshell thinning which drastically lowers breeding success. Laws banning the use of DDT were passed by New York State in 1971 and by the federal government in 1972. Although DDT contamination has been reduced in this country, it continues to affect the peregrine and its prey.

5. Environmental Baseline Conditions

5.1 Hudson River

The Hudson River is 315 miles (507 km) long from its source at Lake Tear of the Clouds in the Adirondacks to the mouth at the Battery in New York City. The Hudson River is tidal for 153 miles (246 km) from the mouth to the Federal Dam at Troy. Salt water travels about 60 miles (97 km) up the river to Newburgh, New York.

The site is located on the Hudson River approximately 83 river miles (RM) north of New York Harbor, and 75 RM below the Federal Dam in Troy. The Hudson River is tidal below the Federal Dam. The extent of the salt wedge (100 milligrams per liter of chloride) occurs in the southern part of the Hudson River and may reach as far north as Poughkeepsie during very dry years (USGS, 2017). Water temperature taken at a location 3.5 mi south of the Mid-Hudson Bridge indicated the highest temperature after October 1, 2007 was 28.6 °C; the lowest water temperature after that date was -0.2 °C, Feb. 6, 7, 2010.

5.1.1 Deepwater Habitat

Deepwater areas provide habitat for a diversity of marine species in the Hudson River. The Kingston-Poughkeepsie Deepwater Habitat is designated by the NYSDOS as a Significant Coastal Fish and Wildlife Habitat (SCFWH). This SCFWH is an extensive section of deepwater habitat in the Hudson River. It is an approximately 6,350 acre habitat that encompasses a 25 mile stretch of the Hudson River extending approximately from Kingston Point in the City of Kingston in Ulster County and the Village of Rhinecliff in Dutchess County to just south of Wappinger Creek in the Town of Wappinger in Dutchess County. This SCFWH area is located 200 feet offshore of the site.

Deepwater areas support a diversity of freshwater and migratory species in the Hudson River. Fish species found in this section of river include fourspine stickleback (*Apeltes quadracus*), hogchoker (*Trinectes maculatus*), killifish (*Fundulus diaphanous*), threespine stickleback (*Gasterosteus aculeatus*), white perch (*Morone americana*), bluegill (*Lepomis macrochirus*), brown bullhead (*Ameiurus nebulosus*), common carp (*Cyprinus carpio*), golden shiner (*Notemigonus crysoleucas*), largemouth bass (*Micropterus salmoides*), pumpkinseed (*Lepomis gibbosus*), smallmouth bass (*Micropterus dolomieu*), spottail shiner (*Notropis hudsonius*), white catfish (*Ameiurus catus*), yellow perch (*Perca flavescens*), alewife (*Alosa pseudoharengus*), American eel (*Anguilla rostrata*), American shad (*Alosa sapidissima*), blueback herring (*Alosa aestivalis*), and striped bass (*Morone saxatilis*).

Recent fisheries investigations of the Hudson River indicate spawning as well as wintering of sturgeon in this area. Habitat requirements of this species in the Hudson River are not well known. Shortnose sturgeon use the portion of the river which generally is greater than 30 feet in depth. This area is also significant since it is largely responsible for the abundance of marine species upriver (the northern range limit for many in New York), especially during periods of low freshwater flows (summer). During the spring spawning run of shad, commercial drift netting takes place in the surface waters overlying this area (NYSDOS 2012a).

5.1.2 Benthic Habitat

Benthic community structure and population density are dependent on factors including water quality, sediment type, the presence or absence of submerged aquatic vegetation (SAV), and human alterations. Benthic communities vary in distribution in the Hudson River depending on bottom type (i.e., hard or soft substrate), salinity, SAV, and location along the river. As described in Chapter 4, the benthic community appeared to consist mainly of silts with some detrital material. Many of the areas show the deleterious effects of NAPL and the invasive zebra mussel appears to be abundant in most locations. This evidence would suggest the benthic habitat in the dredged prisms is of lower ecological value.

As shown in Table 4-2, the sediments in the dredge areas mostly consist of silts, with some gravel and wood detritus.

5.1.3 Submerged Aquatic Vegetation

SAV is plants that are always under water. The most common native species of SAV in the Hudson River watershed is water celery (*Vallisneria americana*). SAV provides important habitat for juvenile fish that can hide within the leaves. Many tidal marshes and vegetated areas of the Hudson River are key nurseries for young fish, which may be more subject to predation in the open river. In addition to fish, SAV beds provide habitat for macroinvertebrates, and food for waterfowl, either by eating the plants themselves or eating the animals living in the plant beds. SAV is an important source of oxygen in the water, which aquatic animals need to survive and is used as a key measure of water quality.

The location and amount of SAV beds can change year to year, with one of the most drastic observations occurring in the summer of 2012. Water celery was not found in areas where it was consistently observed in previous years. One possible cause for this decline is that the sediment pulse from Hurricane Irene and Tropical Storm Lee may have inhibited SAV growth by burying stems and blocking light when the paired storms came through the Hudson Valley in the late summer of 2011. The Hudson River Estuary submerged aquatic vegetation survey conducted in 2014 indicated that SAV was not present near the site (NYSDEC 2014).

6. Potential Effects on Federally Listed Aquatic Species

As discussed in Section 1, the USACE has the responsibility under the ESA to determine whether or not the NWS MGP Remediation Project would adversely affect federally listed endangered and threatened species and species proposed for listing and their designated or proposed designated critical habitat.

Potential impacts on ESA-listed species could occur during proposed CHGE dredging and capping activities. As noted in Section 3, there is designated critical habitat for the Atlantic sturgeon in the NWS MGP Remediation Project area. Proposed measures to reduce potentially adverse impacts on ESA-listed species during dredging and capping will be included in the project; these are described in Section 7.2. The determination of effects are discussed in Section 7. Section 8 presents a cumulative effects analysis of the NWS MGP Remediation Project combined with other reasonably foreseeable actions on protected species.

Table 4 presents a summary of the impacts on aquatic protected species, which are discussed in detail in this section.

6.1 Shortnose Sturgeon and Atlantic Sturgeon

Based on the analysis in this section, it has been concluded that any effects on the shortnose sturgeon and Atlantic sturgeon would be insignificant or discountable, and that the NWS MGP Remediation Project may affect, but is not likely to adversely affect, those species (see Table 5).

Table 4

Summary of Impacts on Federally Listed Species by Resource Area

Resource Area	Description of Impacts
Sediment	Localized temporary disturbance to approximately 7.5 acres of river bottom by dredging in the Hudson River, resulting in habitat degradation, avoidance, or loss. Along the shoreline and over the underwater utility crossings where dredging is not feasible, impacted material containment will be provided through capping. The cap will be placed along the entirety of the affected riverbank slope (approximately 1.2 acres) and over portions of the underwater utility crossings (approximately 1.1 acres).
Turbidity	Targeted river sediments will be dredged using an environmental bucket, which is designed to provide flat dredge cuts for maximum control of the dredged surface and seals around the bucket to limit loss of material as the bucket is raised through the water column. All dredging will take place within a containment cell outfitted with turbidity curtains and floating booms on all sides to control any turbidity generated during dredging. Water quality (turbidity) will be monitored for the duration of the dredging by means of three buoy-mounted remote sensing stations that will be moored around the perimeter of the work area to confirm that the containment cell is functioning properly.
Benthic communities	Dredged areas deeper than 2 feet below the existing bathymetry will be backfilled after dredging with certified clean sand to 2 feet below the existing bathymetry. The capped dredged areas will be allowed to reestablish the original (pre-dredging) bathymetry by natural sediment transport processes.
SAV	SAV does not exist in the Hudson River adjacent to the site.
SCFWH	<p>In the Hudson River adjacent to the project site is the Kingston – Poughkeepsie Deepwater Significant Coastal Fish and Wildlife Habitat area (SCFWH). Dredging of the contaminated sediment is anticipated to be conducted from October 2018 to February 2019. Dredging in the SCFWH area of approximately 20,000 cubic yards within approximately 4 acres will be conducted using an environmental bucket within a containment cell which will be outfitted with turbidity curtains that extend to the river bottom and floating booms on all sides to control turbidity beyond the dredging area.</p> <p>As part of the coastal zone consistency determination, a Habitat Impairment Test was performed, The HIT determined that although there would be a minor short-term disruption to a small area within the SCFWH, overall, the long term benefits would be positive due to the removal of NAPL-laden sediments.</p>
Vessel Strikes	Construction vessels proposed for use during dredging and capping operations would have relatively shallow drafts. Sturgeon are generally found within 3.3 feet (1.0 meter) of the bottom in the deepest available water. Therefore, the chance of vessel-related mortalities to sturgeon are expected to be negligible.

Table 5

Determination of Effect under the ESA for Federally Listed Aquatic Species in the NWS MGP Remediation Project Area

Common Name	Scientific Name	ESA Status	Determination of Effect
Shortnose sturgeon	<i>Acipenser brevirostrum</i>	T	May affect, but not likely to adversely affect
Atlantic sturgeon	<i>Acipenser oxyrinchus</i>	T ¹ , E ^{2,3,4,5}	May affect, but not likely to adversely affect

Table Key: E = Federally listed as endangered; T = Federally listed as threatened.

Notes:

1. Gulf of Maine DPS.
2. New York Bight DPS.
3. Chesapeake Bay DPS.
4. Carolina DPS.
5. South Atlantic DPS.

6.2 Impacts on Sturgeon Prey

Sediment disturbances from dredging approximately 7.9 acres and capping of approximately 4.2 acres of the dredged areas would result in a short-term loss of benthic organisms and shellfish that serve as forage for Atlantic and shortnose sturgeon. The impacts from these activities would be short term.

Because the habitat disturbance would affect a relatively small amount of the river bottom and because of the temporary nature of the disturbance, the remediation activities in the Hudson River are expected to result in negligible reductions in benthic shellfish and infaunal organisms that serve as prey for shortnose and Atlantic sturgeon. There will be an ecological benefit to the water column and benthic habitat in the dredging area due to the removal of the sediment contaminated by the operation of the former MGP facility. As such, impacts on benthic resources which serve as sturgeon prey from sediment disturbance are expected to be insignificant.

7. Remediation Activities in the Hudson River

Construction Window: As described below, sediment disturbance, temporary increases in turbidity and associated water quality degradation, sediment redeposition, and vessel strikes would have an insignificant effect on shortnose and Atlantic sturgeon. Construction windows were determined based upon the information provided by GARFO (2017) when the shortnose and Atlantic sturgeon use the Hudson River. Tables 1 and 3 illustrate the life history stages (spawning, rearing, and overwintering) of shortnose and Atlantic sturgeon and the period of the year when these life stages are present. The proposed dredging at the site are anticipated to be conducted between October 2018 and February 2019 and would avoid the life history stages of the shortnose and Atlantic sturgeon in the Hudson River at the site. Additionally, the less intrusive capping of the underwater utility crossing areas and the river slope is anticipated to be conducted between July 2019 and September 2019, after the published key migratory spawning season (March 1 and June 30).

Articulated Capping System: The slope of the shoreline along the bulkhead cannot be dredged due to the shallow depth of the water and stability issues with the slope. A sheetpile bulkhead wall will be installed as part of the bulkhead remediation activities. To isolate the impacted sediment remaining beyond the sheetpile bulkhead wall from the river, approximately 1.2 acres of articulated capping system consisting of RCM with grout filled molds will be installed along the river slope (Appendix A).

Concrete Mats: Since dredging cannot be conducted in the area of the existing underwater gas electric, and fiber optic lines that extend across the Hudson River, an approximately one acre area near and over the utility crossings will be capped with a cover system consisting of RCM overlain by armored concrete blocks to isolate the impacted sediment in these areas. Placement of concrete mats would bury the existing benthic community (if present), including potential prey for Atlantic and shortnose sturgeon. Although individuals among the existing benthic communities might be impacted, installation of the concrete mats would not preclude the survival of benthic infaunal species and shellfish. Shortnose and Atlantic sturgeon would be able to use adjacent areas for foraging and other activities. Installation of these materials could cause a permanent change in benthic habitat from soft sediments to the hard substrate of the concrete mats within the footprint of the concrete mats. Concrete mats provide hard substrate habitat, and gaps in the mats provide velocity refuge and cover for aquatic invertebrates and small fishes (Fischenich 2003), possibly including benthic prey for shortnose and Atlantic sturgeon. Where concrete mats would be installed, habitat could be permanently altered, but the area requiring concrete mats is very small relative to the available habitat for shortnose and Atlantic sturgeon. When the concrete mats are placed in areas of fine sediment, the spaces between the individual concrete elements would be filled by suspended sediment and the surficial habitat would be partially restored. It is likely that some sediment would accumulate on the concrete mats, resulting in some benthic habitat re-colonization. New and functional communities would be expected to recolonize these areas over time.

Best Management Practices: To minimize impacts to Hudson River during the implementation of the remedial activities, water-based best management practices (BMPs) will be implemented prior to the start of work. The BMPs are typical of the types of controls successfully used at other environmental remediation projects to minimize impacts to riverine systems. BMPs and engineering controls including the containment cell will be installed prior to the start of the dredging and will be used throughout the

dredging. Additionally, dredged areas will be backfilled with clean sand imported from upland sources and transported to the site via barge. Dredged material will be dewatered at the site and shipped off-site for treatment and disposal.

Water-based control measures will include performing the dredging, backfilling, and capping work within containment (i.e., turbidity curtain), and implementing surface water and water column monitoring activities. These BMPs will monitor, control and isolate potential sediment, NAPL and sheen releases to the river thereby reducing turbidity and oxygen demands and protecting against siltation.

Turbidity Curtains: Prior to the dredging of NAPL impacted sediments, a turbidity curtain will be installed around the perimeter of the dredge areas. Absorbent booms will be installed in sediment dredging areas to contain the migration of any NAPL sheens that may be encountered during sediment removal activities. The turbidity curtain system will be inspected and maintained through the duration of sediment dredging activities.

Shortnose and Atlantic sturgeon are found in turbid waters (Dadswell et al. 1984) and feed on benthic invertebrates and are, therefore, tolerant of suspended sediment at the levels that are temporarily generated by marine construction activities (NMFS 2013a). NMFS concluded that the effect of suspended sediment concentrations in the range of 10 to 350 mg/L from construction activities for a marina project in the Haverstraw Bay region would not be significant to shortnose sturgeon. It is anticipated that the impact of suspended sediment would be similarly insignificant for the closely related Atlantic sturgeon. Citing the literature, NMFS indicated that the concentrations of total suspended sediments that would be expected to show adverse impacts on fish would be 580.0 mg/L for the most sensitive species, with 1,000 mg/L being more typical (FHWA 2012).

Water Quality Monitoring: Visual surface water monitoring will occur throughout the dredging and backfilling operation. Oil absorbent booms and/or pads will be used around all platforms and turbidity curtain to prevent migration of sheens outside of dredge areas. If NAPL/sheens are observed outside the turbidity curtain, the sheen will be chased and absorbed using absorbent booms and/or pads. The primary controls (turbidity curtains) and sorbent booms next to curtains will be inspected and corrected as necessary to ensure their effectiveness in capturing sediments and NAPL/sheens.

Turbidity Monitoring: A turbidity monitoring program will be performed during the sediment removal and restoration activities. Water quality (turbidity) will be monitored for the duration of the dredging by means of three buoy-mounted remote sensing stations that will be moored around the perimeter of the work area to confirm that the containment cell is functioning properly. Turbidity will be measured at an upstream location, a location near the work zone, and a downstream location within Hudson River.

Inspections of the water-based controls will be conducted each day at the beginning of removal activities. Inspections will also be conducted, as appropriate, in response to visible sediment plumes migrating from the work area or measured turbidity levels above the action level of 50 nephelometric turbidity units (NTUs) above the turbidity level at the upstream monitoring location. Inspections in response to turbidity levels above the action level metric will begin with a surface inspection using a boat. If the reason for the turbidity exceedance cannot be determined through surface inspection, a hand-held turbidity meter or

other appropriate method will be used to identify the source. The Construction Quality Assurance Plan (CQAP) will identify contingency measures to meet turbidity action levels. Contingency measures may include modification to dredge operations (e.g., fall height, cycle time, bucket handling procedures, use of a rinse tank, etc.) or modifications or repairs of the containment systems.

Vessel Strikes: The vessels used during the dredging will include a barge-mounted crane that will conduct the dredging using an environmental bucket. Once this barge is located within the containment cell, the crane barge will be only moved when necessary to complete the dredging within the containment cell. Adjacent to the crane barge and outside of the containment cell will be a dredged material barge. The dredge crane will place the dredged material in this barge. When the barge is filled, it will be moved by a tug boat the short distance to the shoreline to remove the standing water for treatment on the upland of the site. After the water has been treated, it will be discharged in accordance with the SPDES Permit Equivalency. The dredged material and the solids will be transported to an offsite facility via barge where the material will be stabilized and disposed at an approved disposal facility.

Based on the types of vessels to be employed and their relatively shallow draft, there should always be sufficient clearance between vessels and the river bottom. The typical draft of the barges is approximately 12 feet (4 meters). Additionally, reduced vessel speeds in the dredging area (less than 4 knots) would help to avoid vessel strikes for sturgeon near the surface. As such, the possibility of a vessel striking shortnose or Atlantic sturgeon during dredging or capping is discountable.

8. Conclusions

8.1 Effects Determination for Listed Species

Based on the description of the NWS MGP Remediation Project in Section 2 of this BA and further described in the status of species and environmental baseline described in Sections 3 and 4, and the analysis of potential impacts in Section 5, it is concluded that:

The NWS MGP Remediation Project may affect, but is unlikely to adversely affect, the shortnose sturgeon or any DPS of Atlantic sturgeon. Sediment disturbance, temporary increases in turbidity and associated water quality degradation, sediment redeposition, noise and vibration, vessel strikes, and accidental releases of hazardous materials are not expected to have significant effects on shortnose sturgeon and Atlantic sturgeon. Conservation measures such as establishment of construction windows to avoid seasonal periods where sensitive species are using these portions of the rivers would avoid, or minimize to insignificant levels, adverse effects on federally listed sturgeon species. .

8.2 Effects Determination for Critical Habitat

On August 17, 2017, critical habitat was designated for the Endangered New York Bight, Chesapeake Bay, Carolina and South Atlantic Distinct Population Segments of Atlantic Sturgeon and the Threatened Gulf of Maine Distinct Population Segment of Atlantic Sturgeon (82 *Federal Register* 39160). This Final Rule became effective September 18, 2017. Critical habitat has been designated for the Atlantic sturgeon in the Hudson River from the southern end of Manhattan, NY to the Troy Lock and Dam in Rensselaer County, NY. The proposed dredging of approximately 7.6 acres would have a temporary adverse impact on Atlantic sturgeon foraging habitat.

According to the GARFO Master Species Table for Atlantic sturgeon (Table 3), utilization of the Hudson River for spawning takes place well north of the site in late spring to summer. During rearing in late spring to summer, Atlantic sturgeon eggs, larvae, juveniles and young-of-year occupy the Hudson River at different life stages from the Tappan Zee Bridge north to Kingston. However during the winter when the proposed dredging would take place, rearing does not occur. According to GARFO, foraging takes place in tidally influenced flats and the lower Hudson River in the summer. Overwintering adults use the lower Hudson River during the winter while juveniles use the river between RKM 19 (Yonkers) to RKM 75 south of Poughkeepsie and the site.

Based upon the data provided in the GARFO Master Species Table for Atlantic sturgeon, the proposed dredging and capping project may affect, but is not likely to adversely affect designated Atlantic sturgeon critical habitat in the Hudson River.

9. References

- ASA 2012 ASA Analysis & Communication, Inc. (ASA). 2014. 2012 Year Class Report for the Hudson River Estuary Monitoring Program. Prepared for Dynege Roseton LLC, Entergy Nuclear Indian Point 2 LLC, Entergy Nuclear Indian Point 3 LLC, ASMFC and Mirant Bowline LLC.
- ASA 2013 ASA. 2013. 2011 Year Class Report for the Hudson River Estuary Monitoring Program. Prepared for Dynege Roseton L.L.C., Entergy Nuclear Indian Point 2 LLC, Entergy Nuclear Indian Point 3 LLC., and Mirant Bowline LLC.
- ASMFC 2008 Atlantic States Marine Fisheries Commission (ASMFC). 2008. *A Cooperative State-Federal Program for Conservation of Atlantic Coastal Fisheries – Hudson River Atlantic Sturgeon Tagging Study*. Final Report for Grant Number A05NMF4741276. Prepared by the Hudson River Fisheries Unit, NYSDEC, New Paltz, New York.
- ASMFC. 2017. Habitat Addendum IV to Amendment 1 of the Interstate Fisheries Management Plan for Atlantic Sturgeon. Available online: http://www.asmfc.org/uploads/file/sturgeonHabitatAddendumIV_Sept2012.pdf. Accessed 28 November 2017.
- ASSRT 2007 Atlantic Sturgeon Status Review Team (ASSRT). 2007. Status Review of Atlantic Sturgeon (*Acipenser oxyrinchus oxyrinchus*). National Marine Fisheries Service, Silver Spring, Maryland.
- Bain 1997 Bain, M.B. 1997. Atlantic and shortnose sturgeons of the Hudson River: Common and divergent life history attributes. *Environmental Biology of Fishes* 48: 347-358.
- Bain et al. 2000 Bain, M.B., N. Haley, D. Peterson, J.R. Waldman, and K. Arend. 2000. Harvest and habitats of Atlantic sturgeon *Acipenser oxyrinchus* Mitchell, 1815, in the Hudson River estuary: Lessons for sturgeon conservation. *Boletín-Instituto Español de Oceanografía* 16: 43-53.
- Basov 1999 Basov, B.M. 1999. "Behavior of Sterlet Sturgeon (*Acipenser ruthenus*) and Russian Sturgeon (*A. gueldenstaedtii*) in Low-Frequency Electric Fields." *Journal of Ichthyology*. 39:782-787.
- Bell et al. 2006 Bell, R.E., R.D. Flood, S. Carbotte, W.B.F. Ryan, C. McHugh, M. Cormier, R. Versteeg, H. Bokuniewicz, Y.L. Ferrini, J. Thissen, J.W. Ladd, and E.A. Blair. 2006. "Benthic Habitat Mapping in the Hudson River Estuary." Pages 51–64 in J. S. Levinton and J. R. Waldman, ed. *The Hudson River Estuary*. New York: Cambridge University Press.
- Berry, W., N. Rubinstein, B. Melzian, and B. Hill. 2003. *The Biological Effects of Suspended and Bedded Sediment (SABS) in Aquatic Systems: A Review*. Internal Report of the United States Environmental Protection Agency.
- Callahan 1993 Callahan, E.V. 1993. Indiana bat summer habitat requirements. M.S. Thesis. University of Missouri, Columbia. 84 pp.
- Callahan, E.V., R.D. Drobney, and R.L. Clawson. 1997. Selection of summer roosting sites by Indiana bats (*Myotis sodalis*) in Missouri. *Journal of Mammalogy* 78: 818-825.
- Caceres, M.C. and R. Barclay. 2000. *Myotis septentrionalis*. *Mammalian Species*, 634: 1-4.

Caceres, M.C. and M.J. Pybus. 1997. Status of the Northern Long-Eared Bat (*Myotis septentrionalis*) in Alberta. Available online: <<http://srd.alberta.ca/FishWildlife/SpeciesAtRisk/SpeciesAtRiskPublicationsWebResources/Mammals/documents/SARStatusNorthernLongEaredBatAlberta-1997.pdf>>. Accessed 29 October 2013.

Carter, A., E. Hague, and L. Floyd. 2008. Benthic Infauna Recovery Following Channel Dredging in the Vicinity of Bogue Inlet, North Carolina. In *Proceedings of the 2008 National Conference on Beach Preservation Technology*. February 2008.

Carter, A., E. Hague, L. Floyd. 2008. "Benthic Infauna Recovery Following Channel Dredging in the Vicinity of Bogue Inlet, North Carolina." In *Proceedings of the 2008 National Conference on Beach Preservation Technology*. February 2008.

Clarke, D.G., and D.H. Wilber. 2000. *Assessment of Potential Impacts of Dredging Operations due to Sediment Resuspension*. DOER Technical Notes Collection (ERDC TN-DOER-E9). US Army Engineer Research and Development Center, Vicksburg, Mississippi.

Coch, N. K. 1986. "Sediment Characteristics and Facies Distributions." *Northeastern Geology* 8 (3): 109–129.

Dadswell, M.J., B.D. Taubert, T.S. Squiers, D. Marchette, and J. Buckley. 1984. Synopsis of Biological Data on Shortnose Sturgeon, *Acipenser brevirostrum* LeSueur 1818. NOAA Technical Report NMFS/S 140. National Marine Fisheries Service, Silver Spring, Maryland.

Dovel, W. L. and T. J. Berggren. 1983. "Atlantic Sturgeon of the Hudson River Estuary, New York." *New York Fish and Game Journal* 30:140–172.

Dovel, W.L., A.W. Pekovitch, and T.J. Berggren. 1992. Biology of the shortnose sturgeon (*Acipenser brevirostrum* Lesueur 1818) in the Hudson River Estuary, New York. Pages 187-216 in C.L. Smith (ed). *Estuarine Research in the 1980s*. State University of New York Press, Albany, New York.

ESS Group, Inc. 2011. Concrete Mattress Macroinvertebrate and Video Census Monitoring Report. Long Island Replacement Cable (LIRC) Project. Prepared for Northeast Utilities Services Company as agent for the CT Light & Power Company, Berlin, Connecticut by ESS Group, Inc., Wellesley, Massachusetts.

Federal Highway Administration (FHWA). 2012. "Biological Assessment for the Tappan Zee Hudson River Crossing Project." Available online: <http://www.tzsite.com/tzbsite_2/deis_2.html>. Accessed 14 November 2017.

Findlay, S, C. Wigand, and W.C. Nieder. 2006. "Submersed Macrophyte Distribution and Function in the Tidal Freshwater Hudson River." Pages 230–241 in J. S. Levinton and J. R. Waldman, ed., *The Hudson River Estuary*. New York: Cambridge University Press.

Fischenich, J.C. 2003. *Effects of Riprap on Riverine and Riparian Ecosystems*. ERDC/EL TR-03-4. U.S. Army Engineer Research and Development Center, Vicksburg, Mississippi.

Gardner, J.E., J.D. Garner, and J.E. Hoffman. 1991. Summer Roost Selection and Roosting Behavior of *Myotis sodalis* (Indiana bat) in Illinois. Illinois Natural History Survey, Bloomington, Illinois.

Geoghegan, P., M.T. Mattson, and R.G. Keppel. 1992. Distribution of the shortnose sturgeon in the Hudson River estuary, 1984-1988. Pages 217-241 in C.L. Smith (ed). *Estuarine Research in the 1980s*. State University of New York Press, Albany, New York.

Germano, J.D., and Cary, D. 2005. Rates and effects of sedimentation in the context of dredging and dredged material placement. *DOER Technical Notes Collection*. March 2005.

Gilbert, C.R. 1989. *Species profiles: Life Histories and Environmental Requirements of Coastal Fishes and Invertebrates (Mid-Atlantic Bight) – Atlantic and Shortnose Sturgeons*. USFWS Biological Report 82(11.122) and USACE Technical Report EL82-4. 28 pp. December 1989.

Greater Atlantic Regional Fisheries Office (GARFO) Master ESA Species Table – Atlantic Sturgeon (NMFS Web site
(https://www.greateratlantic.fisheries.noaa.gov/protected/section7/listing/garfo_master_esa_species_table_-_atlantic_sturgeon_051917.pdf) Accessed December 8, 2017

Greater Atlantic Regional Fisheries Office (GARFO) Master ESA Species Table - Shortnose Sturgeon (NMFS Web site
(https://www.greateratlantic.fisheries.noaa.gov/protected/section7/listing/garfo_master_esa_species_table_-_shortnose_sturgeon_may2017.pdf) Accessed December 8, 2017.

Greene, K.E., J.L. Zimmerman, R.W. Laney, and J.C. Thomas-Blate. 2009. *Atlantic Coast Diadromous Fish Habitat: A Review of Utilization, Threats, Recommendations for Conservation, and Research Needs*. Atlantic States Marine Fisheries Commission Habitat Management Series No. 9, Washington, D.C.

Henderson, L.E. and H.G. Broders. 2008. Movements and Resource Selection of the Northern Long-Eared Myotis (*Myotis septentrionalis*) in a Forest–Agriculture Landscape. *Journal of Mammalogy*, 89(4): 952-963.

Hirsch, N.D., L.H. DiSalvo, and R. Peddicord. 1978. “Effects of dredging and disposal on aquatic organisms.” Technical Report DS-78-5. U.S. Army Engineer Waterways Experiment Station, Vicksburg, MS. NTIS No. AD A058 989.

Kahnle, A.W., K.A. Hattala, K.A. McKown, C.A. Shirey, M.R. Collins, T.S. Squiers, Jr., and T. Savoy. 1998. Atlantic States Marine Fisheries Commission Atlantic Sturgeon Stock Assessment. Peer Review Report.

Kurta, A. 2005. Roosting ecology and behavior of Indiana bats (*Myotis sodalis*) in summer. Pages 29-42 in K.C. Vories and A. Harrington (eds). *The Indiana Bat and Coal Mining: A Technical Interactive Forum*. Office of Surface Mining, U.S. Department of the Interior, Alton, Illinois.

LaSalle, M.W., D.G. Clarke, J. Homziak, J.D. Lunz, and T.J. Fredette. 1991. “A framework for assessing the need for seasonal restrictions on dredging and disposal operations.” Department of the Army, Environmental laboratory, Waterways Experiment Station, Corps of Engineers, Vicksburg, Mississippi.

Murray, S.W., and A. Kurta. 2004. Nocturnal activity of the endangered Indiana bat (*Myotis sodalis*). *Journal of Zoology* 262: 197-206.

NatureServe. 2017. “NatureServe Explorer: An Online Encyclopedia of Life” Available online: <<http://www.natureserve.org/explorer>>. Accessed 21 November 2017.

- Nepf, H.M. and W.R. Geyer. 1996. "Intratidal variation in stratification and mixing in the Hudson estuary." *Journal of Geophysical Research*. 101(C5): 12,079-12,086.
- Newell, R.C., L.J. Seiderer, N.M. Simpson, and J.E. Robinson. 2004. "Impacts of Marine Aggregate Dredging on Benthic Macrofauna off the South Coast of the United Kingdom." *Journal of Coastal Research*. 20(1): 115–125.
- National Marine Fisheries Service (NMFS). 1998. Final Recovery Plan for the Shortnose Sturgeon (*Acipenser brevirostrum*). NMFS, Silver Spring, Maryland. NMFS 2011a NMFS. 2011. *Biological Opinion on the Issuance of a Permit to Evaluate Shortnose Sturgeon Populations in the Hudson River (Number 16439) Pursuant to Section 10 (a)(1) of the Endangered Species Act of 1973*. 21 November 2011.
- NMFS 2011b NMFS. 2011. *Vessel Strikes Working Group Discussion, NMFS Sturgeon Workshop, Alexandria, VA*. National Marine Fisheries Service, Silver Spring, Maryland. 11 February 2011.
- NMFS 2013a NMFS. 2013. *Biological Opinion for the Tappan Zee Bridge Replacement (F/NER/2013/05769)*. 10 April 2013.
- NMFS. 2013. *Biological Opinion for Continued Operations of Indian Point Nuclear Generating Unit Nos. 2 and 3*. 30 January 2013.
- National Oceanic and Atmospheric Administration (NOAA) Office of Protected Resources. 2013. Species Profile: Shortnose Sturgeon: *Acipenser brevirostrum*. Available online: <http://www.nmfs.noaa.gov/pr/species/fish/atlanticsturgeon.htm>. Accessed 24 November 2017.
- New York Natural Heritage Program (NYNHP). 2017. "Shortnose Sturgeon Fact Sheet." Available online: <http://acris.nynhp.org/report.php?id=7168>. Accessed 24 November 2017.
- NYNHP. 2017. "Indiana Bat Factsheet." Available online: <http://www.acris.nynhp.org/report.php?id=7405>. Accessed 24 November 2017.
- NYSBA. 2017. "Falcons Nesting on the Mid-Hudson Bridge." Available online: <http://www.nysba.state.ny.us/.../Peregrine%20Falcons%20Hatch%20on%20Mid-Hudson%2> Accessed 11 December 2017.
- NYSDEC. 2017. "Shortnose Sturgeon Fact Sheet." Available online: <http://www.dec.ny.gov/animals/26012.html>. Accessed 29 November 2017.
- NYSDEC. 2017. "Dwarf Wedgemussel Fact Sheet." Available online: <http://www.dec.ny.gov/animals/42253.html>. Accessed 29 November 2017.
- NYSDEC. 2017. "Peregrine Falcon Fact Sheet" Available online: <http://www.dec.ny.gov/animals/34268.html>. Accessed 11 December 2017.
- NYSDEC. 2017. "Submerged Aquatic Vegetation Habitat." Available online: <http://www.dec.ny.gov/lands/87648.html>. Accessed 30 November 2017.

NYSDOS. 2017. "Significant Coastal Fish & Wildlife Habitats." Available online: <http://www.dos.ny.gov/communitieswaterfronts/consistency/scfwhabitats.html>. Accessed 29 November 2017.

Shortnose Sturgeon Status Review Team (SSSRT). 2010. "Biological Assessment of Shortnose Sturgeon (*Acipenser brevirostrum*)." Available online: http://www.nero.noaa.gov/prot_res/sturgeon/docs/Shortnose%20Sturgeon%20Biological%20Assessment.pdf. Accessed 27 November 2017.

Strayer, D.L. 2006. The benthic animal communities of the tidal-freshwater Hudson River Estuary. Pages 266–278. In J. S. Levinton and J. R. Waldman, ed., *The Hudson River Estuary*. Cambridge University Press, New York.

Sweka, J.A., J. Mohler, M. J. Millard, and T. Kehler. 2007. Juvenile Atlantic Sturgeon Habitat Use in Newburgh and Haverstraw Bays of the Hudson River: Implications for Population Monitoring. *North American Journal of Fisheries Management* 27:1058–1067.

U.S. Department of Energy (USDOE). 2014 "Revised Biological Assessment for Champlain Hudson Power Express Transmission Line Project." July 2014.

U.S. Fish and Wildlife Service (USFWS). 1983. "Recovery Plan for the Indiana Bat." Available online: http://www.fws.gov/midwest/Endangered/mammals/inba/pdf/inba_recplan.pdf. Accessed 28 November 2017.

USFWS. 2017. "Shortnose Sturgeon Fact Sheet." Available online: http://www.fws.gov/northeast/marylandfisheries/reports/Shortnose_fact_sheet_7_21_09.pdf. Accessed 4 December 2017.

USFWS. 2017. "Federally Listed Endangered and Threatened Species and Candidate Species in New York (By County)." 7 November 2017.

USFWS. 2017. "Northern Long-Eared Bat (*Myotis septentrionalis*)." Available online: <http://www.fws.gov/midwest/endangered/mammals/nlba/index.html>. Accessed 29 November 2017.

USFWS. 2017. "Species Profile: Northern Long-Eared Bat (*Myotis septentrionalis*)." Available online: <http://ecos.fws.gov/speciesProfile/profile/speciesProfile.action?spcode=A0JE>. Accessed 27 November 2017.

USFWS. 2017. Species Profile: Shortnose Sturgeon (*Acipenser brevirostrum*). Available online: <http://ecos.fws.gov/speciesProfile/profile/speciesProfile.action?spcode=E00B>. Accessed 28 November 2017.

APPENDIX A

Dredging Figures

File: P:\Jobs\Rem_Eng\Project Files\CHGE\900 CAD\910 CAD\20 SHEETS\PDF\Permitting 2\Permitting Figures.dwg Layout: VICINITY MAP User: erica.hart Plotted: Jan 11, 2018 - 10:06am Xref's:

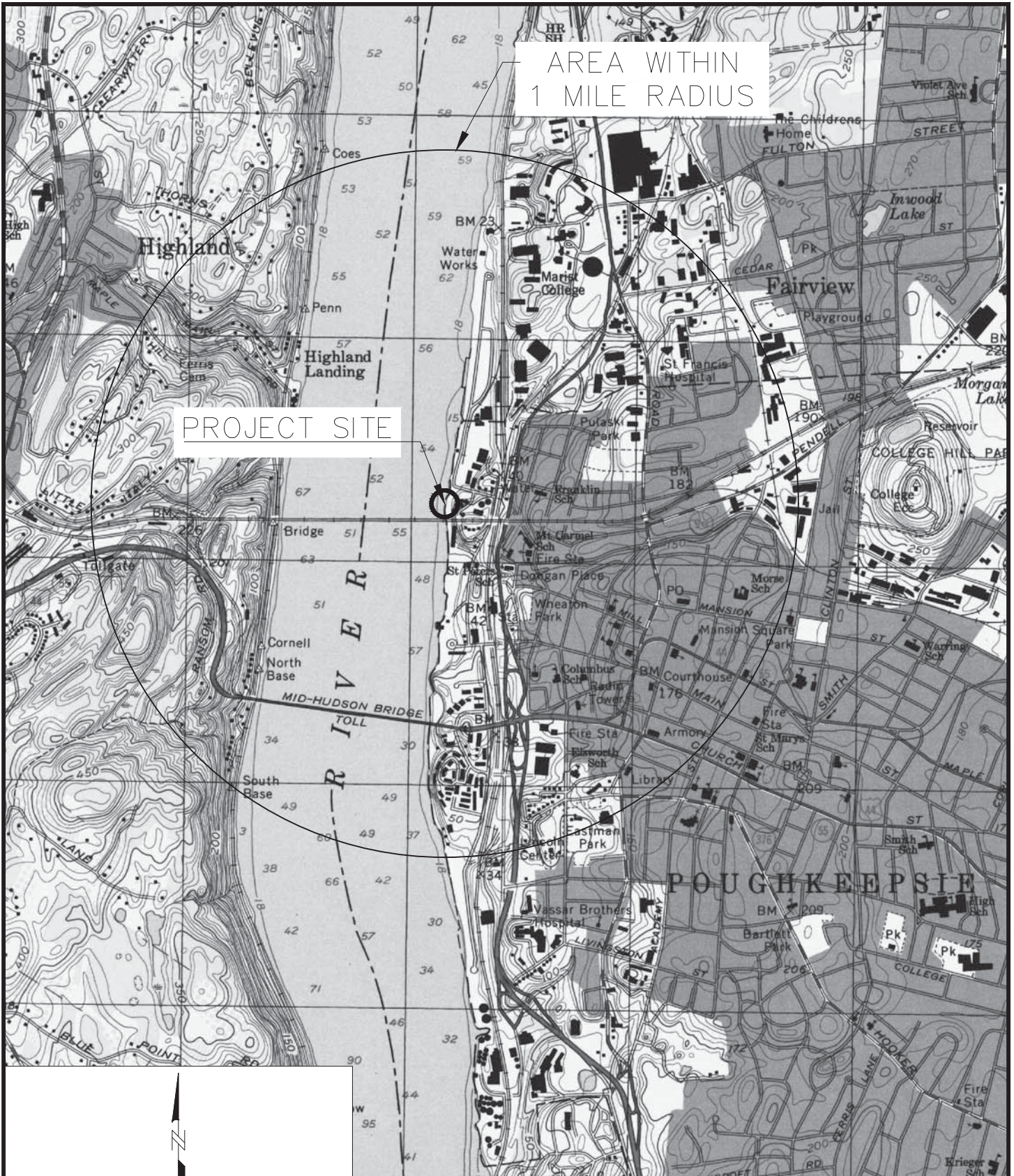

AREA WITHIN 1 MILE RADIUS

PROJECT SITE

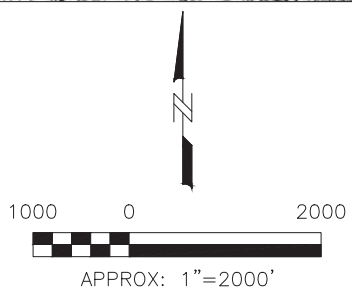

Map Source: U.S.G.S. 7.5' Quadrangle, Poughkeepsie, NY

For Agency Review Only



CENTRAL HUDSON GAS & ELECTRIC
HUDSON RIVER
DUTCHESS COUNTY, NY







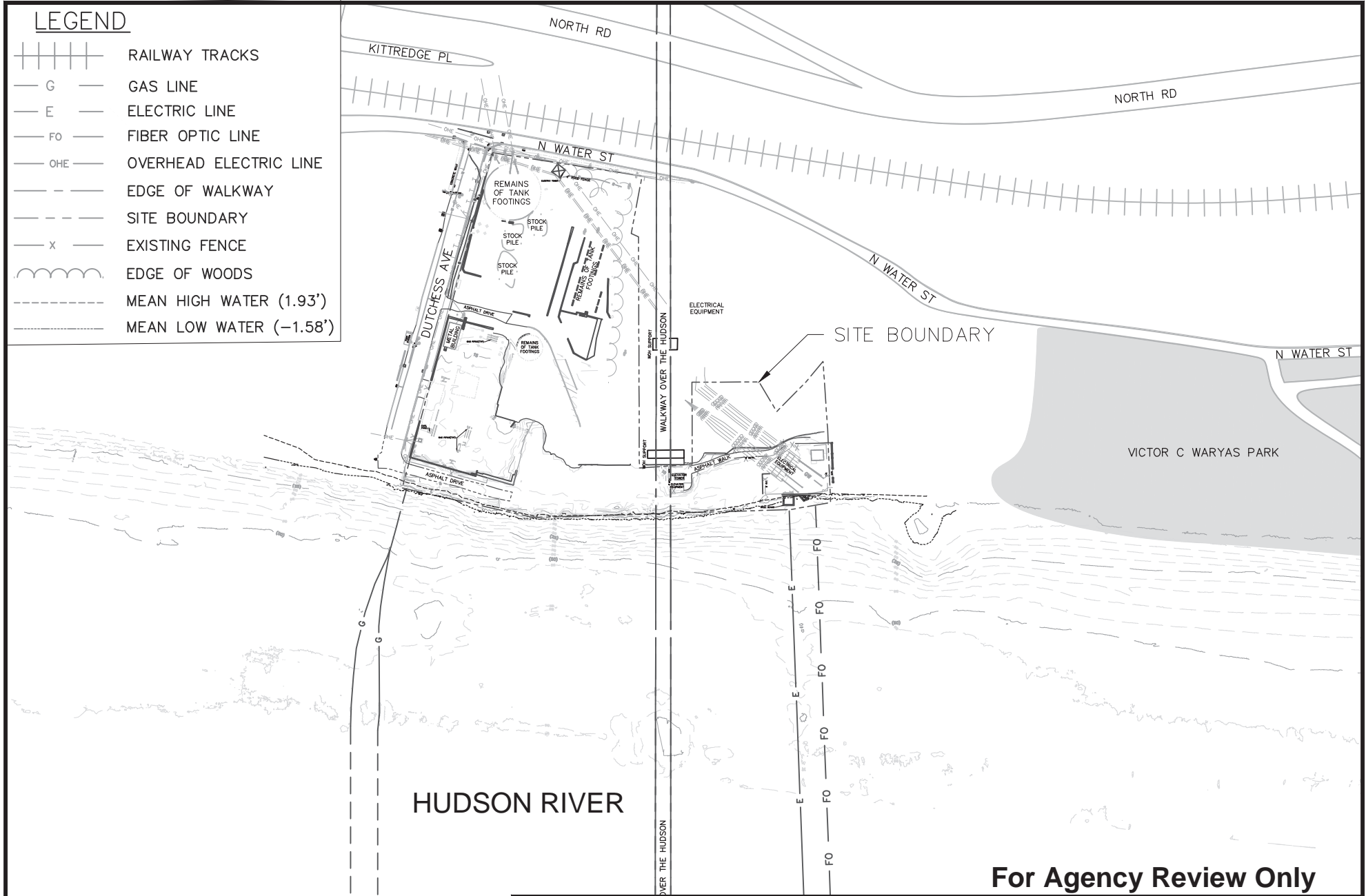



VICINITY MAP
FORMER NORTH WATER STREET MGP
POUGHKEEPSIE

DATE: 1/11/18

FIGURE 1 OF 11

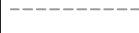

LEGEND

-  RAILWAY TRACKS
-  G GAS LINE
-  E ELECTRIC LINE
-  FO FIBER OPTIC LINE
-  OHE OVERHEAD ELECTRIC LINE
-  EDGE OF WALKWAY
-  SITE BOUNDARY
-  X EXISTING FENCE
-  EDGE OF WOODS
-  MEAN HIGH WATER (1.93')
-  MEAN LOW WATER (-1.58')

For Agency Review Only

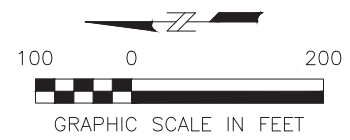

CENTRAL HUDSON GAS & ELECTRIC
 HUDSON RIVER
 DUTCHESS COUNTY, NY
 DATE: 1/11/18

CURRENT SITE LAYOUT AND
 KNOWN UTILITIES
 FORMER NORTH WATER STREET MGP
 POUGHKEEPSIE, NY
 FIGURE 2 OF 11

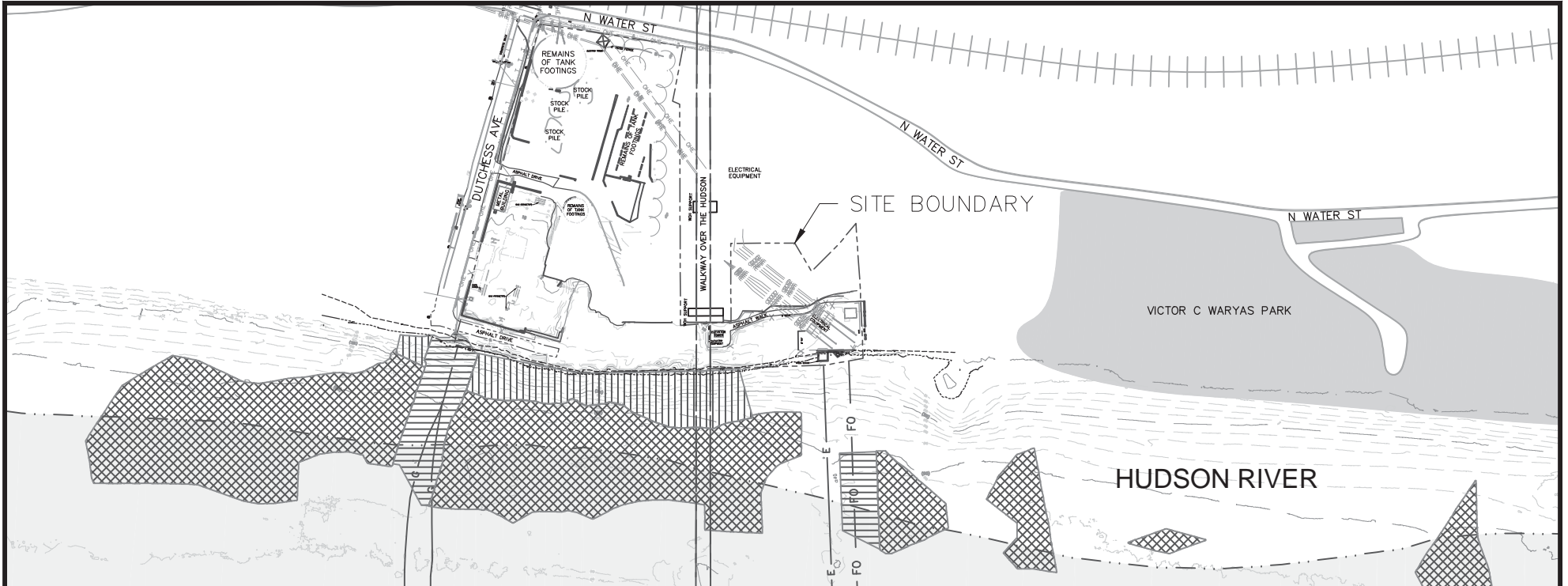

LEGEND

- | | | | |
|--|-------------------------|--|-----------------------------|
| | RAILWAY TRACKS | | |
| | GAS LINE | | PROPOSED SLOPE GRADING AREA |
| | ELECTRIC LINE | | PROPOSED UTILITY CAP AREA |
| | FIBER OPTIC LINE | | DREDGE AREA |
| | OVERHEAD ELECTRIC LINE | | |
| | EDGE OF WALKWAY | | |
| | SITE BOUNDARY | | |
| | EXISTING FENCE | | |
| | EDGE OF WOODS | | |
| | SCFWH AREA BOUNDARY | | |
| | MEAN HIGH WATER (1.93') | | |
| | MEAN LOW WATER (-1.58') | | |

KINGSTON-POUGHKEEPSIE DEEPWATER SCFWH AREA

For Agency Review Only

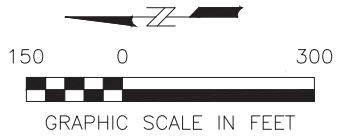

CENTRAL HUDSON GAS & ELECTRIC
HUDSON RIVER
DUTCHESS COUNTY, NY

DATE: 1/11/18

REMEDIAL ACTIVITIES PLAN
FORMER NORTH WATER STREET MGP
POUGHKEEPSIE, NY

FIGURE 3 OF 11

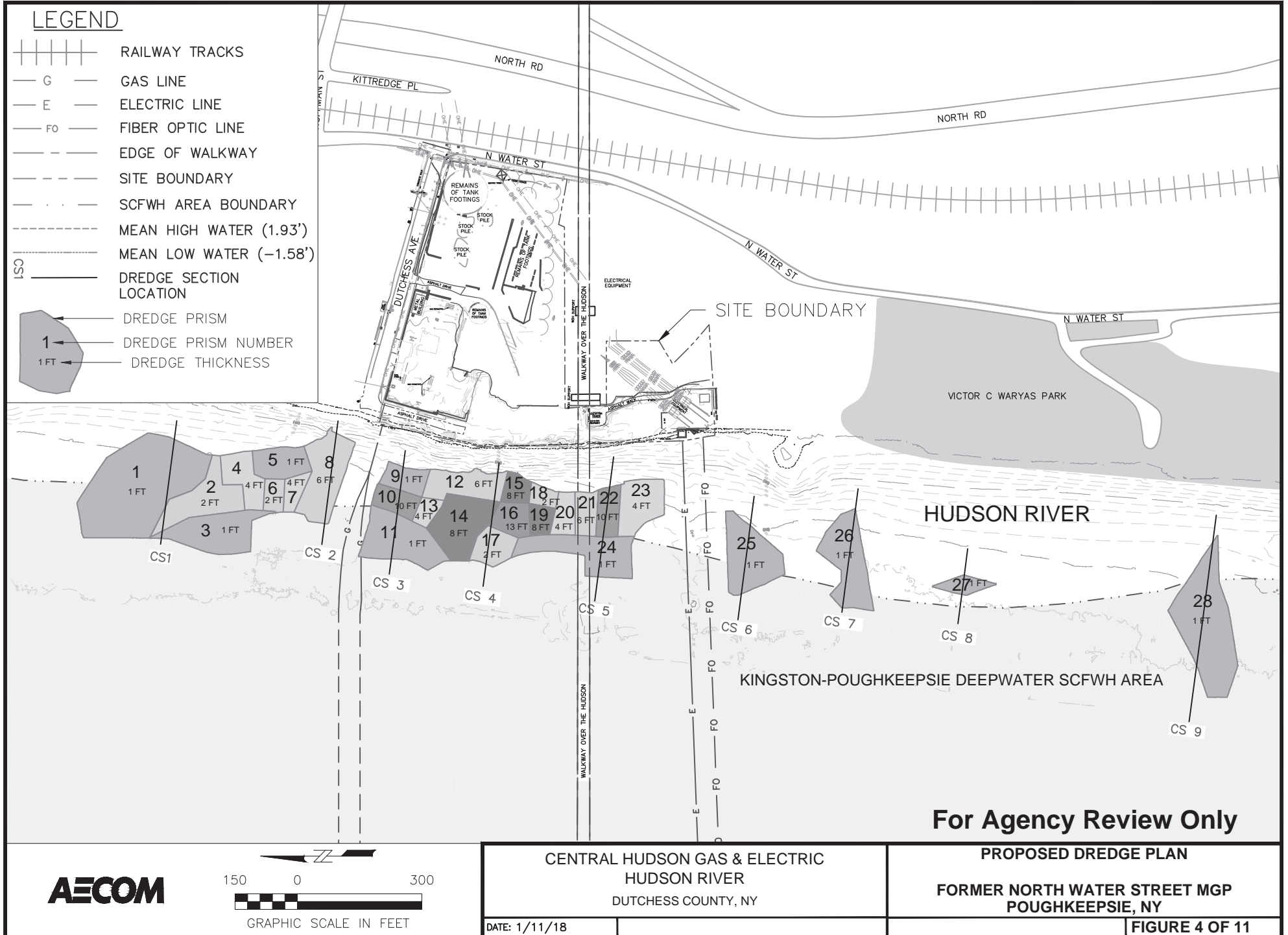

For Agency Review Only

DREDGE SECTION 2

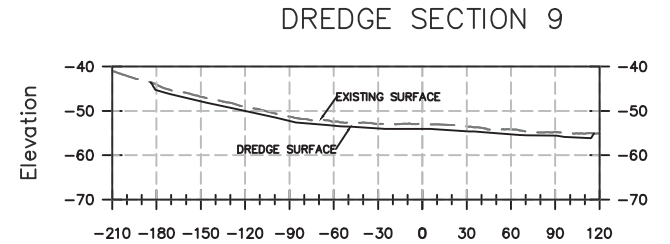
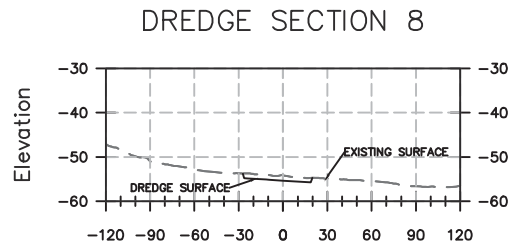
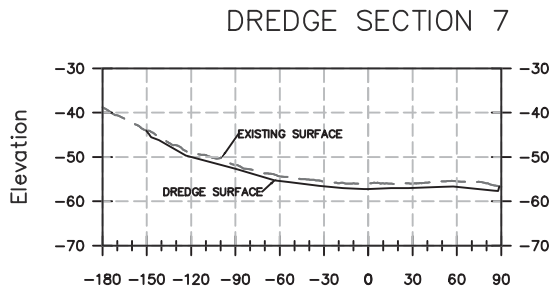
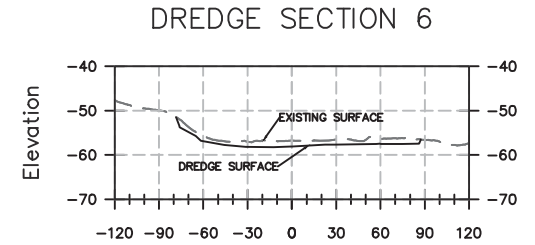
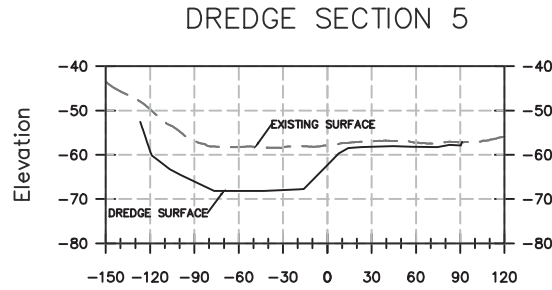
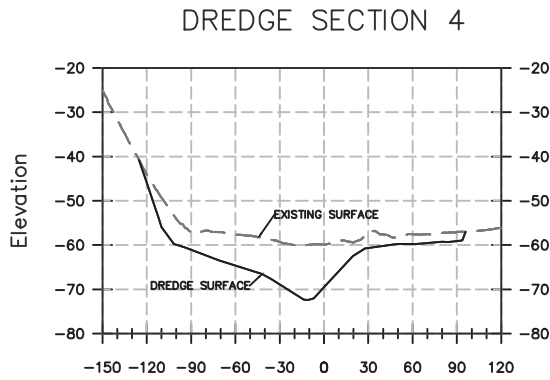
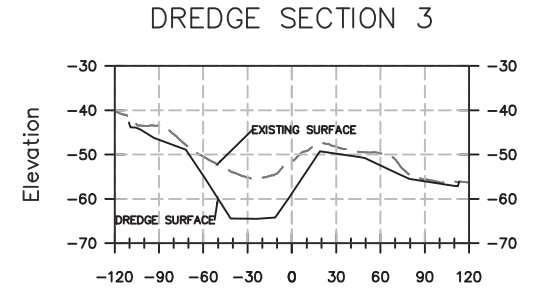
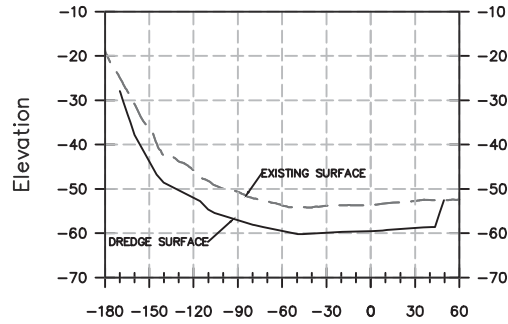
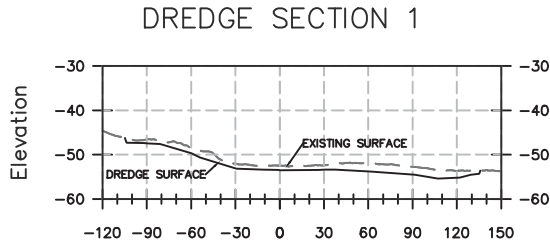

For Agency Review Only



CENTRAL HUDSON GAS & ELECTRIC
HUDSON RIVER
DUTCHESS COUNTY, NY

PROPOSED DREDGE PLAN
CROSS SECTIONS
FORMER NORTH WATER STREET MGP
POUGHKEEPSIE, NY

DATE: 1/11/18

FIGURE 5 OF 11

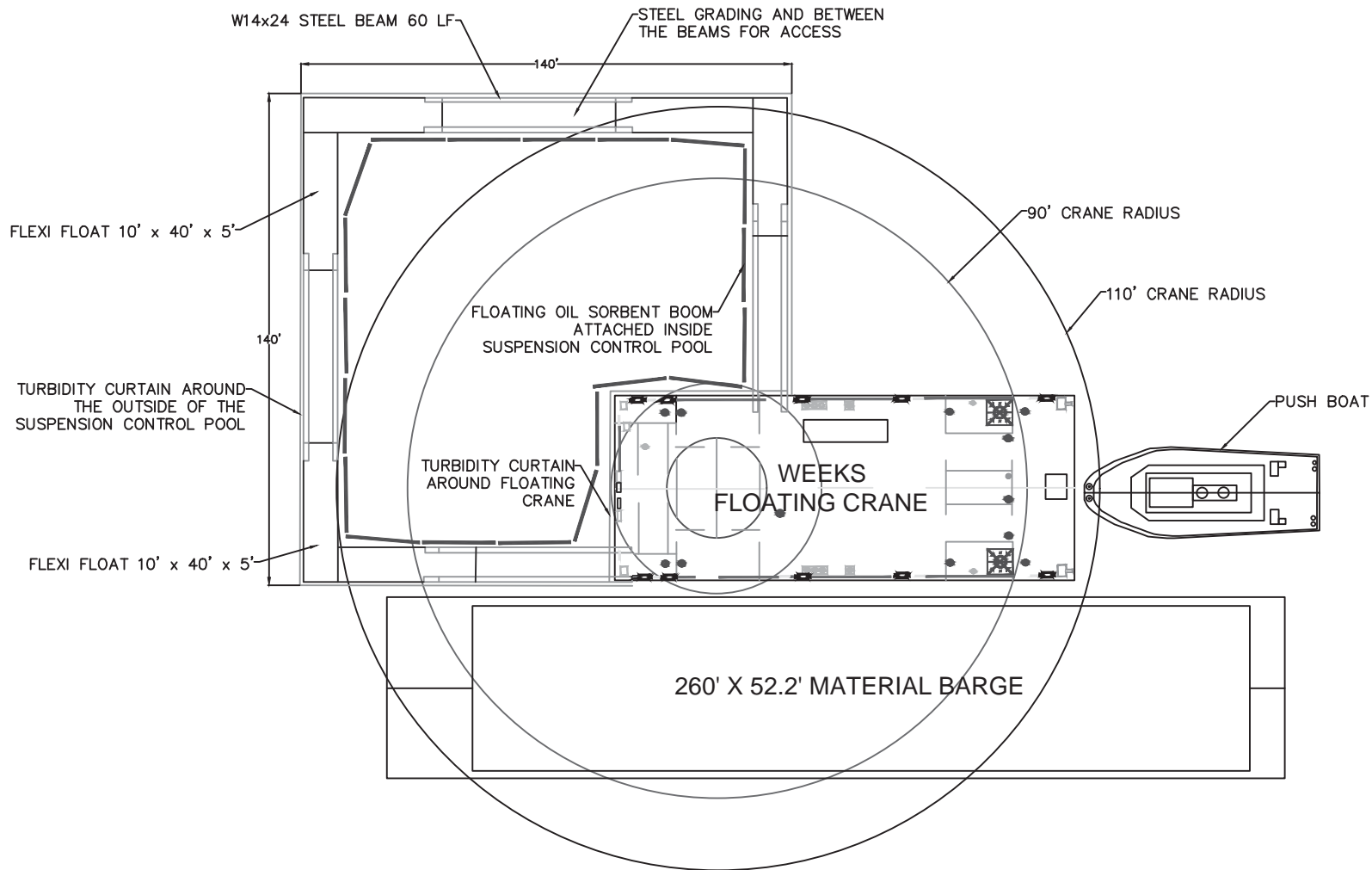

MOBILE SUSPENSION CONTROL SYSTEM SETUP OVERVIEW

NOTE: FIGURES NOT DRAWN TO SCALE. THESE ARE CONCEPTUAL DRAWINGS.

For Agency Review Only



CENTRAL HUDSON GAS & ELECTRIC
HUDSON RIVER
DUTCHESS COUNTY, NY

ENGINEERING CONTROLS
PLAN VIEW
FORMER NORTH WATER STREET MGP
POUGHKEEPSIE, NY

DATE: 1/11/18

FIGURE 6A OF 11

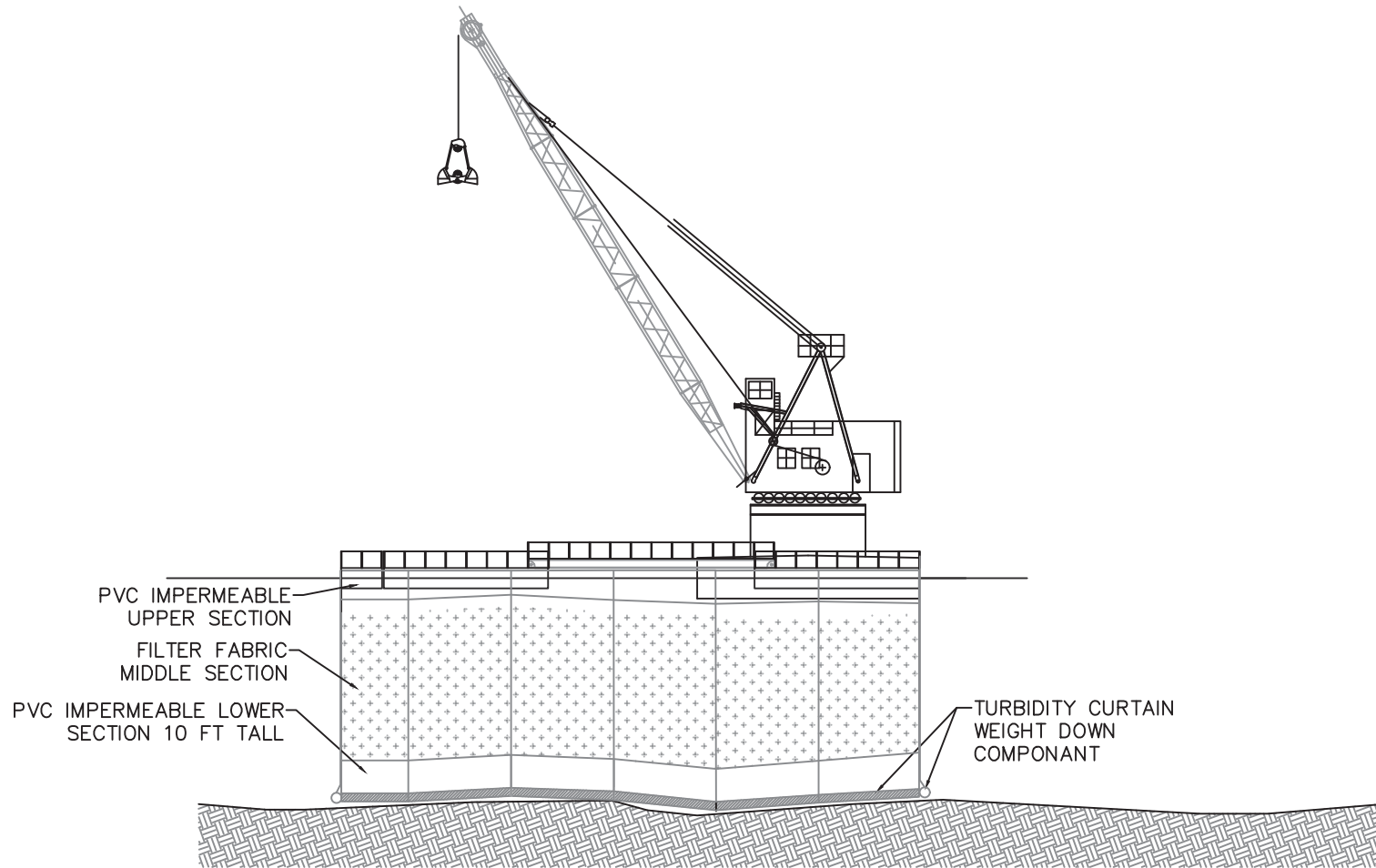

MOBILE SUSPENSION CONTROL SYSTEM SETUP
FRONT VIEW

NOTE: FIGURES NOT DRAWN TO SCALE. THESE ARE CONCEPTUAL DRAWINGS.

For Agency Review Only



CENTRAL HUDSON GAS & ELECTRIC
HUDSON RIVER
DUTCHESS COUNTY, NY

ENGINEERING CONTROLS
SIDE VIEW
FORMER NORTH WATER STREET MGP
POUGHKEEPSIE, NY

DATE: 1/11/18

FIGURE 6B OF 11

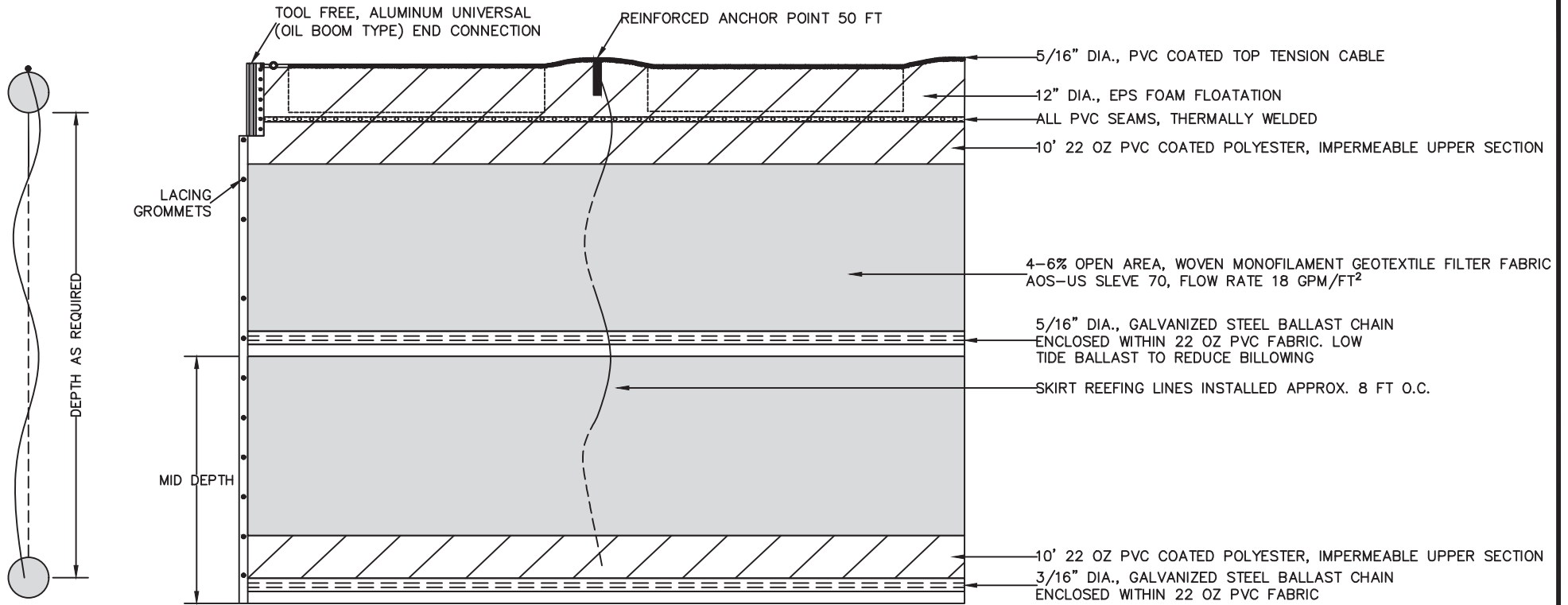

TURBIDITY BARRIER DETAIL

NOTE: FIGURES NOT DRAWN TO SCALE. THESE ARE CONCEPTUAL DRAWINGS.

For Agency Review Only



CENTRAL HUDSON GAS & ELECTRIC
HUDSON RIVER
DUTCHESS COUNTY, NY

ENGINEERING CONTROLS
DETAIL
FORMER NORTH WATER STREET MGP
POUGHKEEPSIE, NY

DATE: 1/11/18

FIGURE 6C OF 11

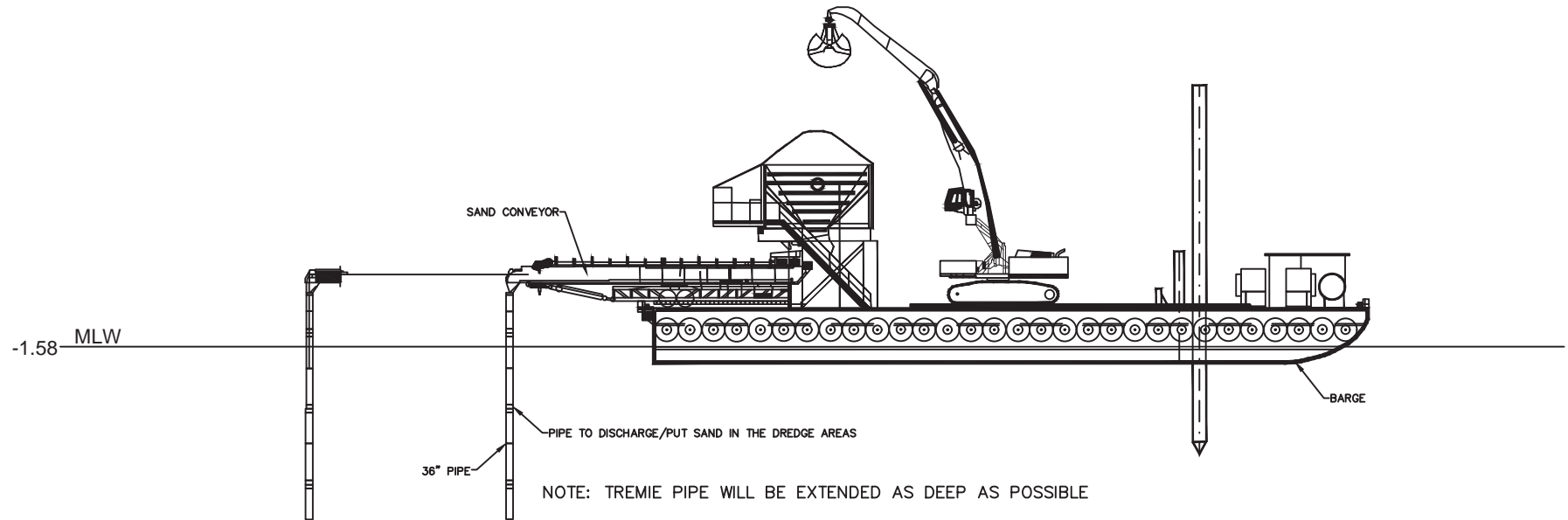

CONCEPTUAL DREDGE RESTORATION OPERATION

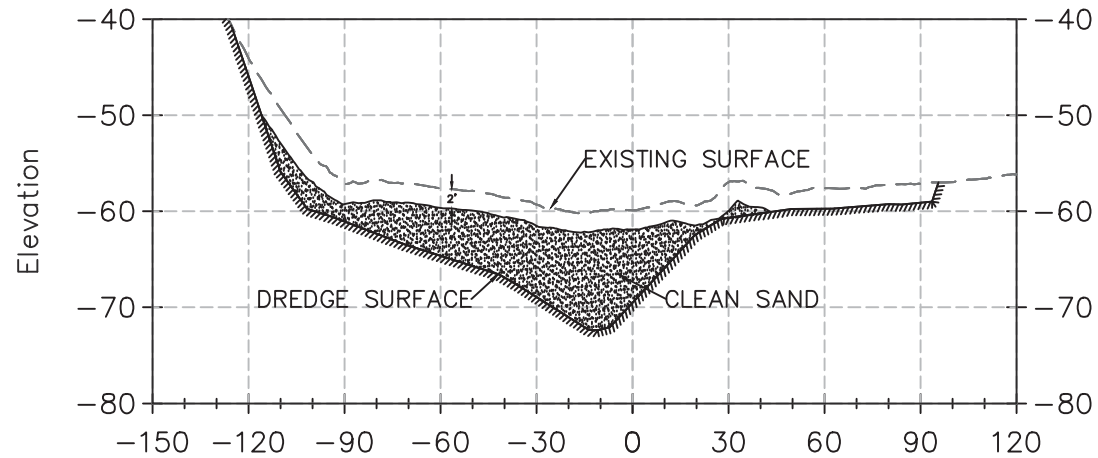

For Agency Review Only



CENTRAL HUDSON GAS & ELECTRIC
HUDSON RIVER
DUTCHESS COUNTY, NY

DREDGE AREA RESTORATION PLAN
FORMER NORTH WATER STREET MGP
POUGHKEEPSIE, NY

DATE: 1/11/18

FIGURE 7 OF 11

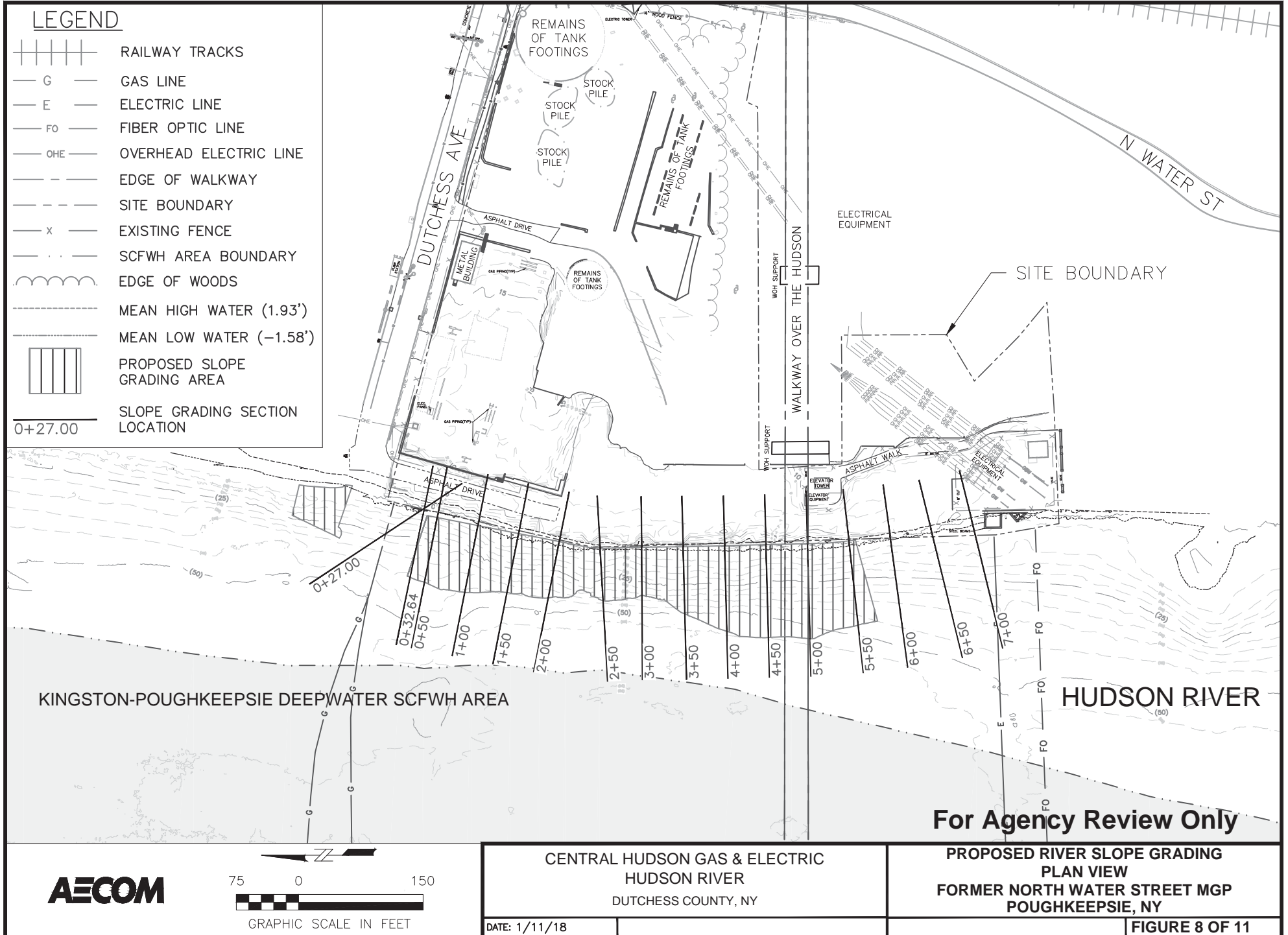

LEGEND

- ORIGINAL SLOPE SURFACE
- RESTORED CAP SURFACE
- . - . DREDGE SURFACE
- - - - - MEAN HIGH WATER (1.93')
- MEAN LOW WATER (-1.58')

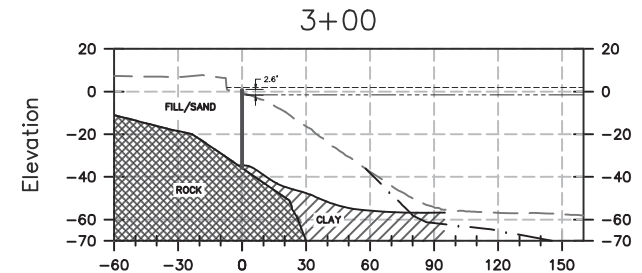
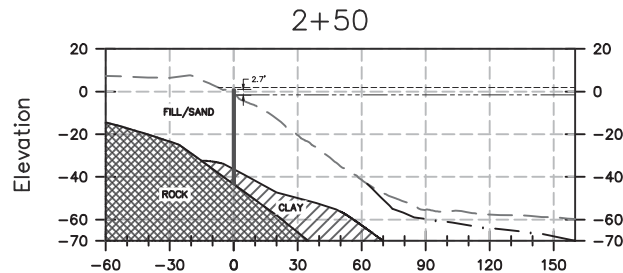
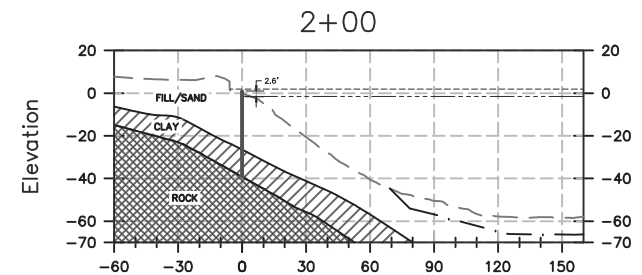
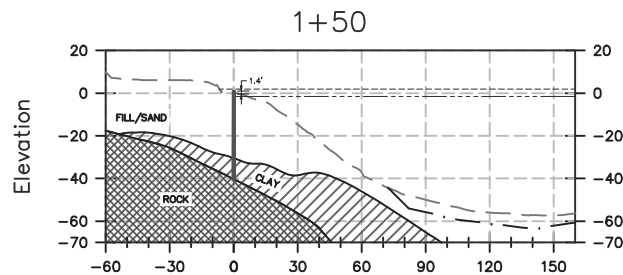
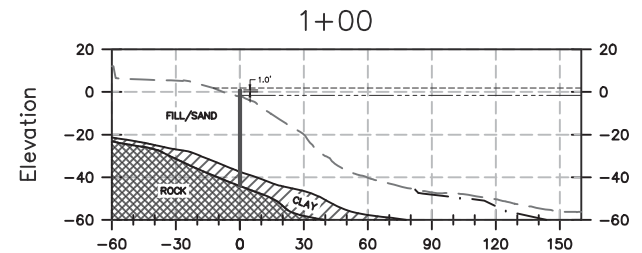
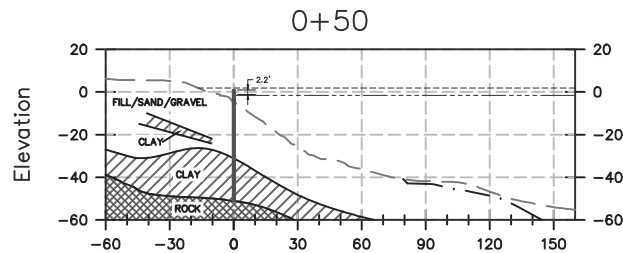
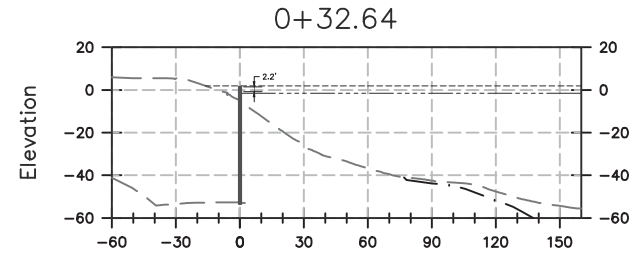
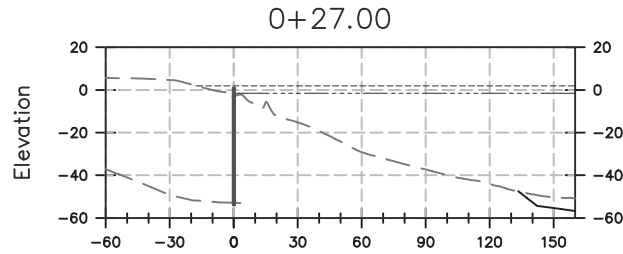

For Agency Review Only



CENTRAL HUDSON GAS & ELECTRIC
HUDSON RIVER
DUTCHESS COUNTY, NY

PROPOSED RIVER SLOPE GRADING
CROSS SECTIONS
FORMER NORTH WATER STREET MGP
POUGHKEEPSIE, NY

DATE: 1/11/18

FIGURE 9A OF 11

LEGEND

- ORIGINAL SLOPE SURFACE
- RESTORED CAP SURFACE
- . - . DREDGE SURFACE
- - - - - MEAN HIGH WATER (1.93')
- MEAN LOW WATER (-1.58')

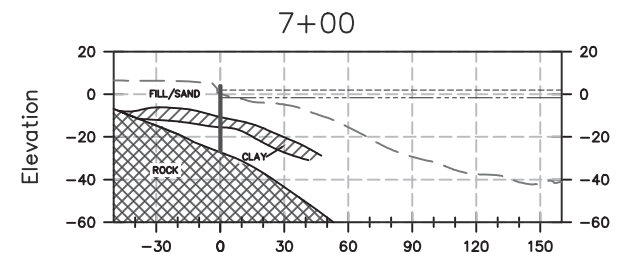
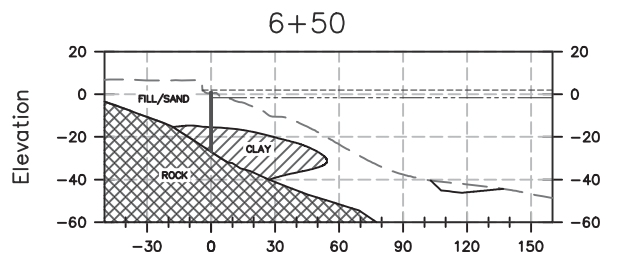
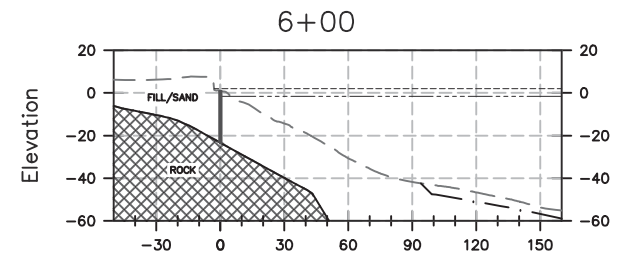
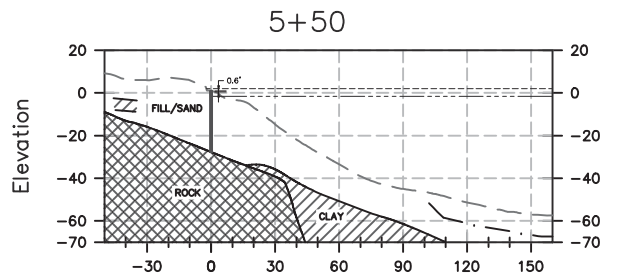
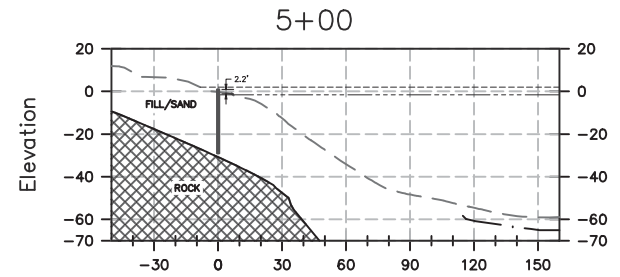
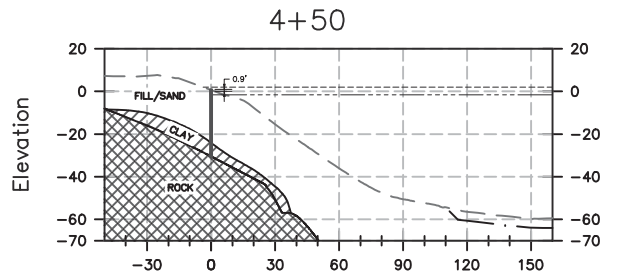
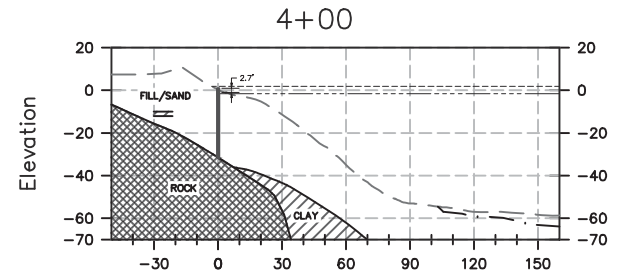
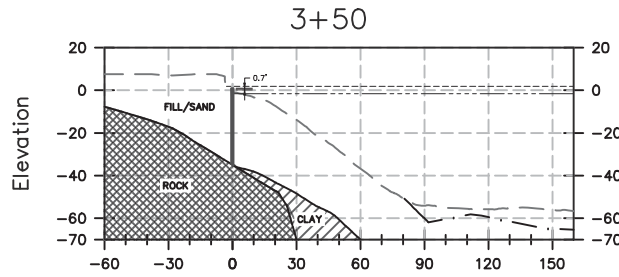

For Agency Review Only



CENTRAL HUDSON GAS & ELECTRIC
HUDSON RIVER
DUTCHESS COUNTY, NY

PROPOSED RIVER SLOPE GRADING
CROSS SECTIONS
FORMER NORTH WATER STREET MGP
POUGHKEEPSIE, NY

DATE: 1/11/18

FIGURE 9B OF 11

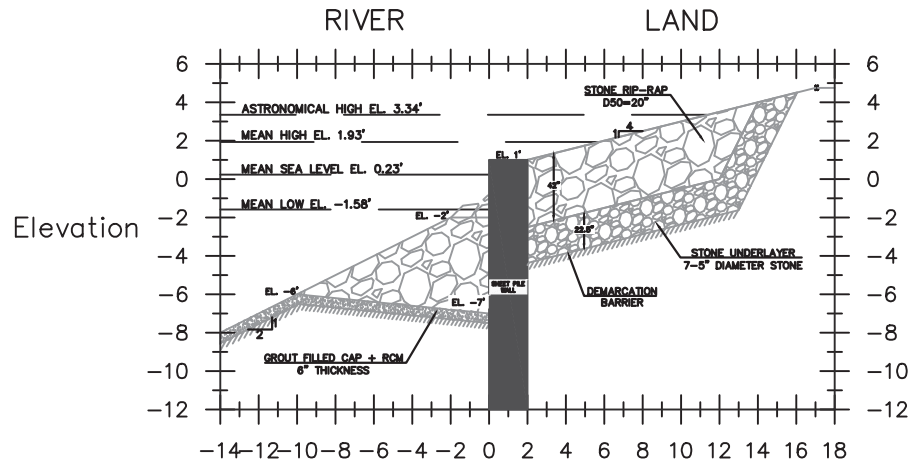

PROPOSED SIDE SLOPE RESTORATION

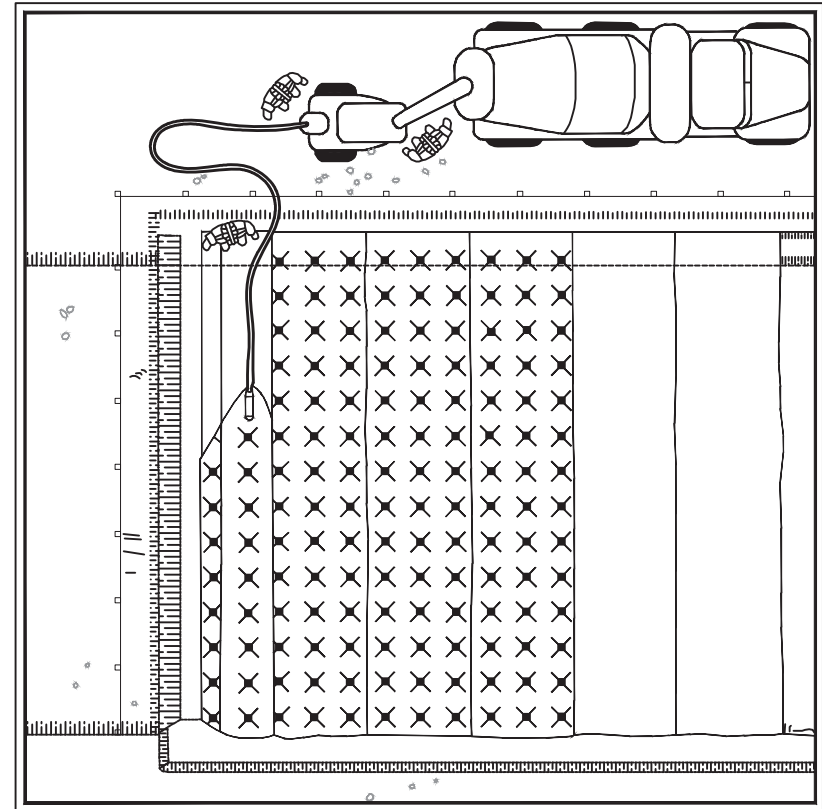

REACTIVE CORE MAT OVERLAID WITH CONCRETE MATTRESSES
ISOMETRIC VIEW

For Agency Review Only



CENTRAL HUDSON GAS & ELECTRIC HUDSON RIVER DUTCHESS COUNTY, NY	DETAILS FOR SIDE SLOPE CAP FORMER NORTH WATER STREET MGP POUGHKEEPSIE, NY
DATE: 1/11/18	FIGURE 10 OF 11

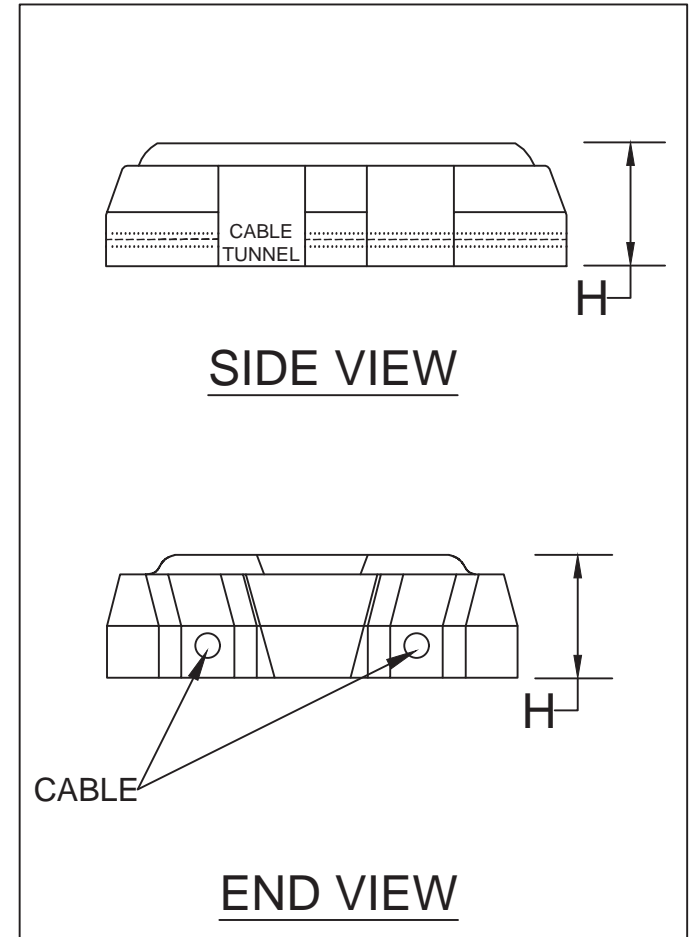
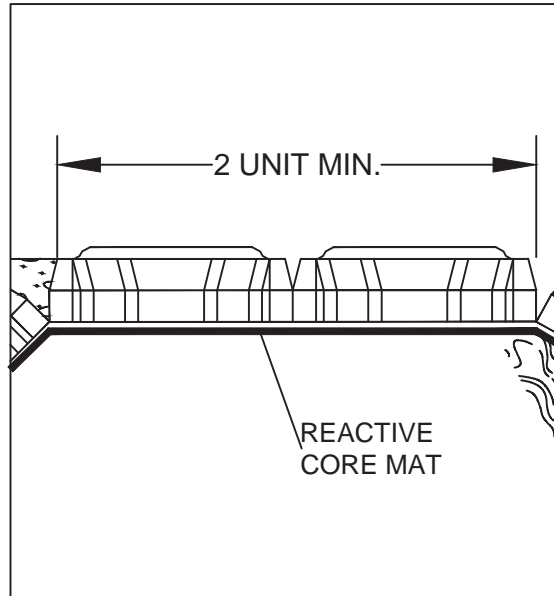
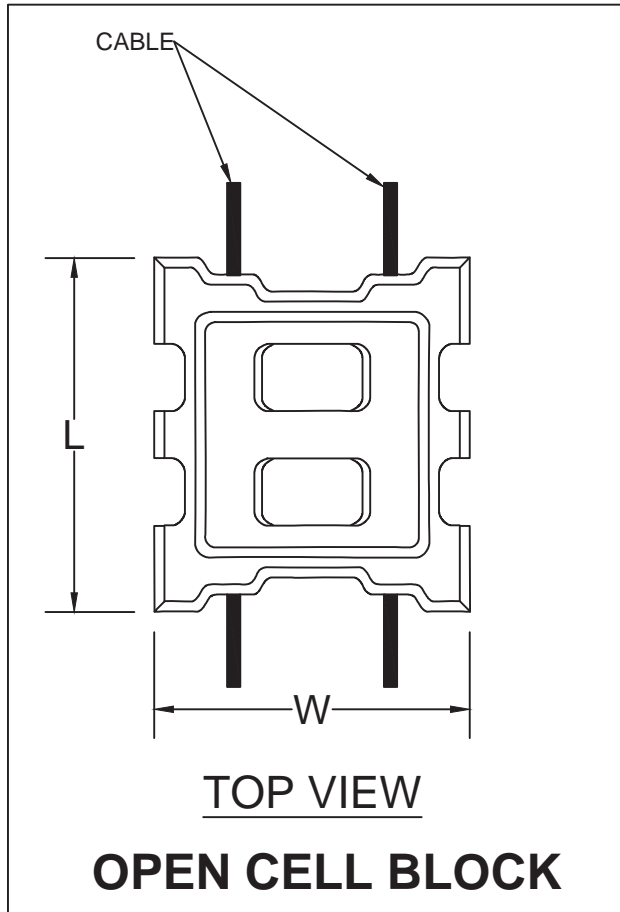

CENTRAL HUDSON GAS & ELECTRIC
HUDSON RIVER
DUTCHESS COUNTY, NY

DATE: 1/11/18

For Agency Review Only

DETAILS FOR UTILITY CAP
FORMER NORTH WATER STREET MGP
POUGHKEEPSIE, NY

FIGURE 11 OF 11

APPENDIX B

Product Description Sheets – Slope Stabilization Material

REACTIVE CORE MAT™

WITH ORGANOCLAY®

DESCRIPTION

ORGANOCLAY® REACTIVE CORE MAT™ is a permeable composite of geotextiles and granular ORGANOCLAY that reliably adsorbs NAPL and low solubility organics from water. Batch isotherm testing by a university determined the following partition coefficients:

- Naphthalene, Kd = 3280 L/kg
- Phenanthrene, Kd = 117,000 L/kg
- Pyrene, Kd - 286,000 L/kg

APPLICATION

ORGANOCLAY® REACTIVE CORE MAT™ is designed for use in the following applications:

- In situ subaqueous cap for contaminated sediments or post-dredge residual sediments
- Embankment seepage control
- Groundwater remediation

BENEFITS

- ORGANOCLAY® REACTIVE CORE MAT™ provides a reactive material that treats contaminants carried by advective/diffusive flow
- Reactive cap allows for thinner cap thickness than a traditional sand cap
- Geotextiles provide stability and physical isolation of contaminants

AVAILABILITY

ORGANOCLAY® REACTIVE CORE MAT™ is available from the following CETCO plant locations:

- 92 Highway 37, Lovell, WY



REACTIVE CORE MAT™ is designed to provide a simple method of placing active materials into subaqueous sediment caps.

PACKAGING

15' by 100' rolls, packaged on 4" PVC core tubes wrapped with polyethylene plastic packaging.

TESTING DATA

PHYSICAL PROPERTIES		
PROPERTY	TEST METHOD	RESULT
ORGANOCLAY¹		
Bulk Density Range	ASTM D 7481	44 - 56 lbs/ft ³
Oil Adsorption Capacity	CETCO Test Method	0.5 lb of oil per lb of ORGANOCLAY, min
Quaternary Amine Content	ASTM D 7626	25 - 33% quaternary amine loading
FINISHED RCM PRODUCT		
ORGANOCLAY Mass per Area	CETCO Test Method	0.8 lb/ft ²
Mat Grab Strength ²	ASTM D4632	90 lbs. MARV
Hydraulic Conductivity ³	ASTM D4491	1 x 10 ⁻³ cm/sec minimum

NOTES:

¹ ORGANOCLAY properties performed periodically on material prior to incorporation into the RCM

² All tensile testing is performed in the machine direction

³ Permittivity at constant head of 2 inches and converted to hydraulic conductivity using Darcy's Law and RCM thickness per ASTM D5199 for geotextiles

North America: 847.851.1800 | 800.527.9948 | www.CETCO.com

© 2014 CETCO. IMPORTANT: The information contained herein supersedes all previous printed versions, and is believed to be accurate and reliable. For the most up-to-date information, please visit www.CETCO.com. CETCO accepts no responsibility for the results obtained through application of this product. CETCO reserves the right to update information without notice.

UPDATED: NOVEMBER 2013

TDS_RCM-ORGANOCLAY_AM_EN_201311_v1



Armortec Product Details

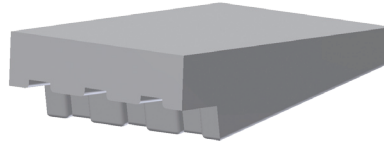

ArmorWedge[®]

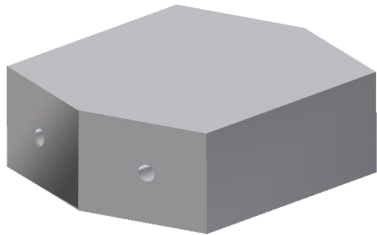

ArmorRoad[®]

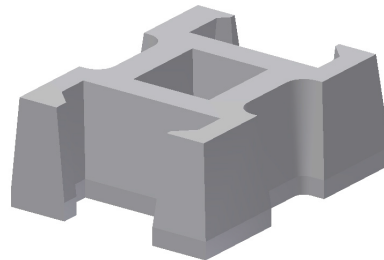

ArmorLoc[®]

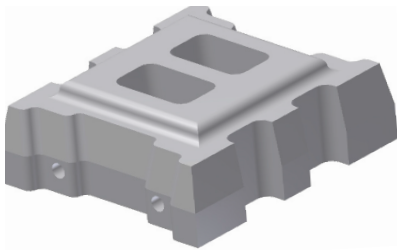

ArmorFlex[®] - Open Cell

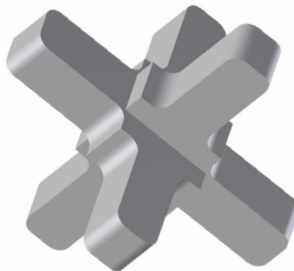

A-Jacks[®]

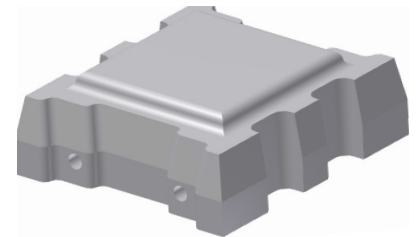

ArmorFlex[®] - Close Cell

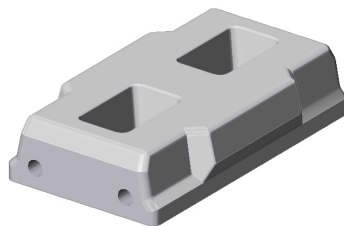

ArmorStone[®]

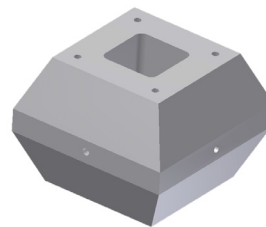

ArmorFlex[®] OS

MANUFACTURING SPECIFICATION
ASTM D6684-04

ArmorFlex® (not to scale)

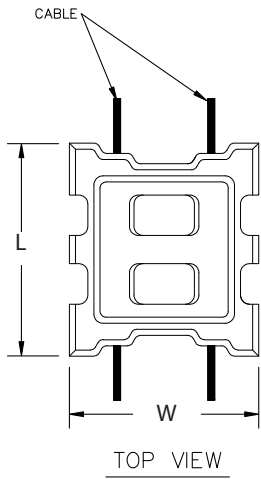

Open Cell Block

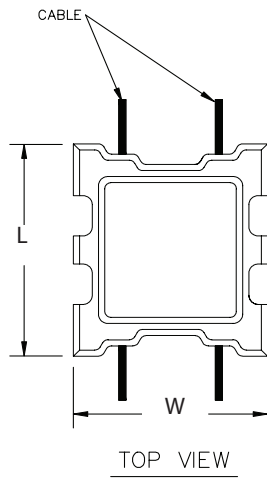

Close Cell Block

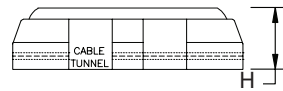

SIDE VIEW

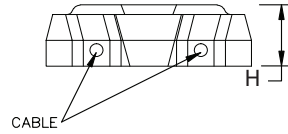

END VIEW

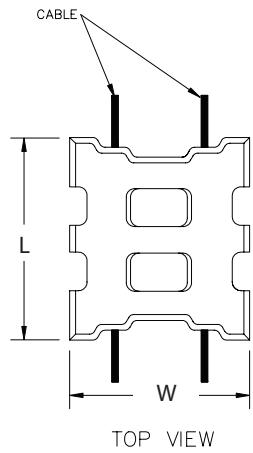

Tapered Series

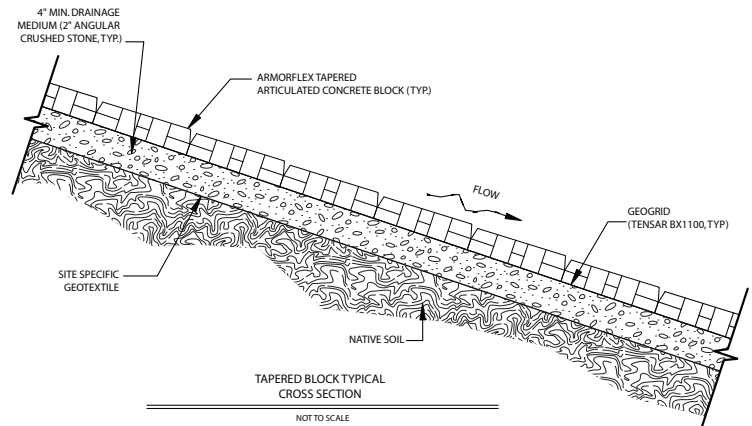
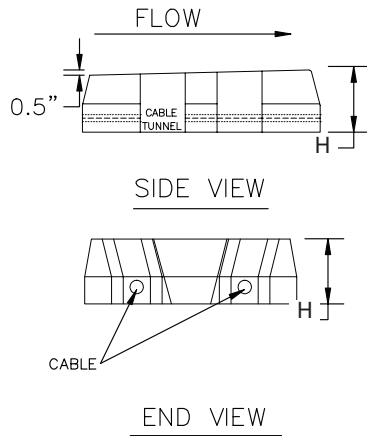

Tapered Series - Cross Section

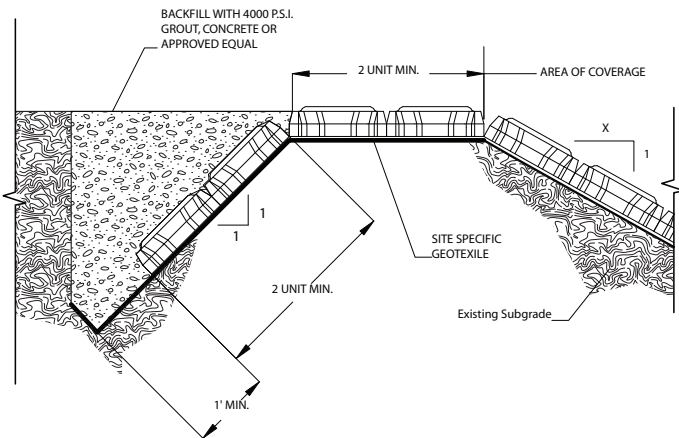

Top of Slope - Standard Detail

ArmorFlex Unit Specification

Concrete Block Class	Open/Closed Cell	Nominal Dimensions			Gross Area/ (sq. ft.)	Block Weight		Open Area %
		L	W	H		lbs	lbs/sq. ft.	
30s	Open	13.0	11.6	4.75	0.98	31-36	32-37	20
50s	Open	13.0	11.6	6.00	0.98	45-52	45-53	20
40	Open	17.4	15.5	4.75	1.77	62-71	35-40	20
50	Open	17.4	15.5	6.00	1.77	81-94	46-53	20
70	Open	17.4	15.5	8.50	1.77	120-138	68-78	20
40L	Open	17.4	23.6	4.75	2.58	90-106	35-41	20
70L	Open	17.4	23.6	8.50	2.58	173-201	67-78	20
45s	Closed	13.0	11.6	4.75	0.98	39-45	40-45	10
55s	Closed	13.0	11.6	6.00	0.98	53-61	54-62	10
45	Closed	17.4	15.5	4.75	1.77	78-89	43-50	10
55	Closed	17.4	15.5	6.00	1.77	94-108	53-61	10
85	Closed	17.4	15.5	8.50	1.77	145-167	82-98	10
45L	Closed	17.4	23.6	4.75	2.58	108-126	42-49	10
85L	Closed	17.4	23.6	8.50	2.58	209-243	81-94	10

High Velocity Application Block Classes

40-T	Open	17.4	15.5	4.75	1.77	62-71	35-40	20
50-T	Open	17.4	15.5	6.00	1.77	81-94	46-53	20
70-T	Open	17.4	15.5	8.50	1.77	120-138	68-78	20

ArmorFlex® cont. (not to scale)

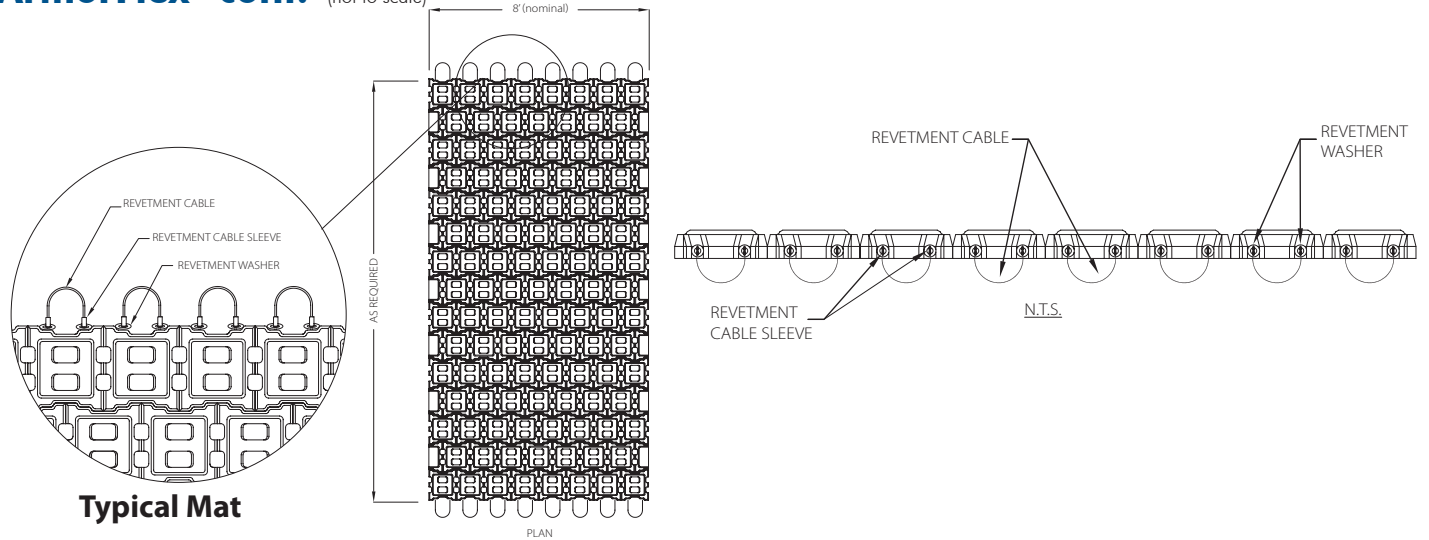

A-Jacks® (not to scale)

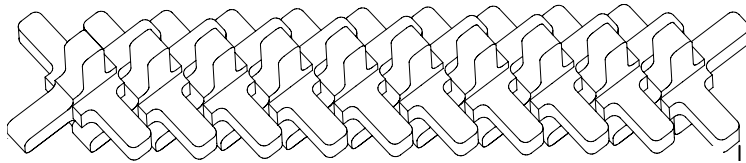

A-Jacks Placement Profile

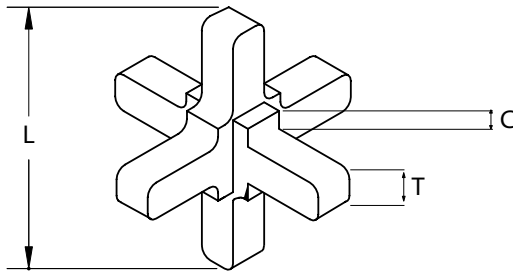

A-Jacks Unit

A-Jacks Unit Specification

A-JACKS	L(IN)	T(IN)/H(IN)	C(IN)	VOL(FT³)	WT (LBS)
AJ-24	24	4	1.84	0.56	78
AJ-48	48	7.36	3.68	4.49	629
AJ-72	72	11.04	5.52	15.14	2.120
AJ-96	96	14.72	7.396	35.87	5.022
AJ-120	120	18.40	9.20	70.69	9.699

ArmorWedge® (not to scale)

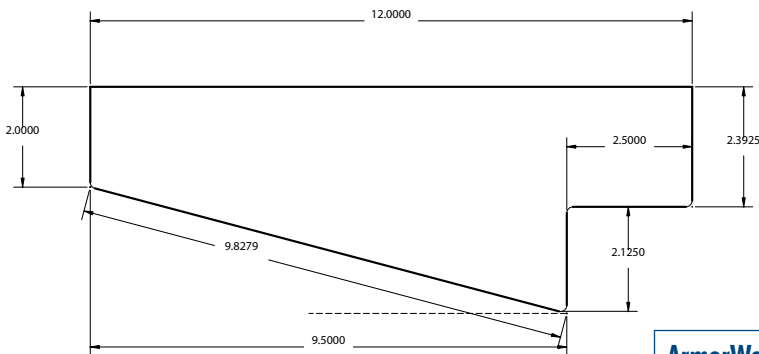

Side View - Typical Block

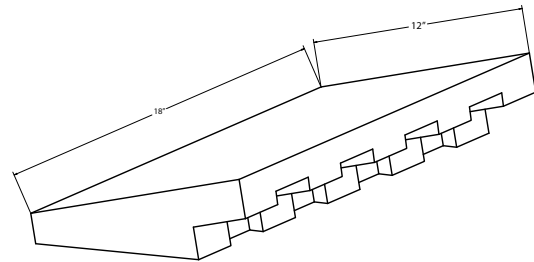

ArmorWedge Unit Specification

UNIT DIMENSION	UNIT WEIGHT (LBS)	SYSTEM WEIGHT (LBS)	UNIT COVERAGE (SF)	COMPRESSIVE STRENGTH (PSI)	MAXIMUM ABSORPTION (LBS/FT³)
12x18	40-52	36-40	1.1875	4000	12

ArmorLoc® (not to scale)

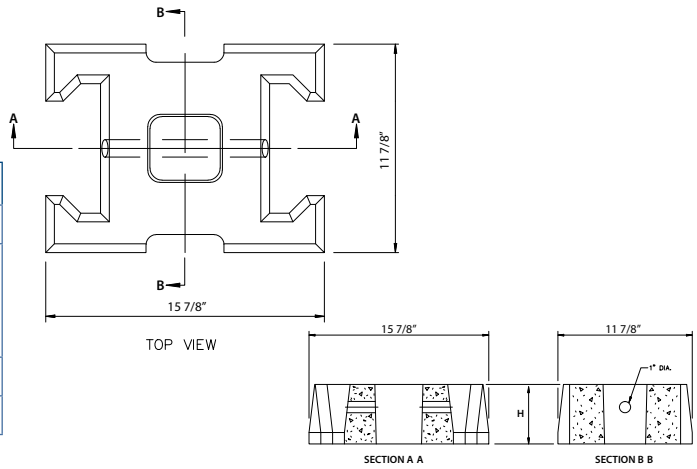

ArmorLoc Unit Specification

BLOCK	TECHNICAL DATA			DIMENSIONS AND WEIGHTS				
	Specific Weight lbs/ft ³	Compressive Strength psi	Max Absorption, Avg. of 3 units 10 lbs/ft ³	Thickness Inches (H)	Gross Area/ Grid ft ²	Weights/ Grid lbs	Weights/ Area lbs/ft ²	Open Area %
3510	130-150	4000 min	10	4	1.0	30-35	30-35	25
4511	130-150	4000 min	10	5.25	1.1	44-50	40-45	20

ArmorStone® (not to scale)

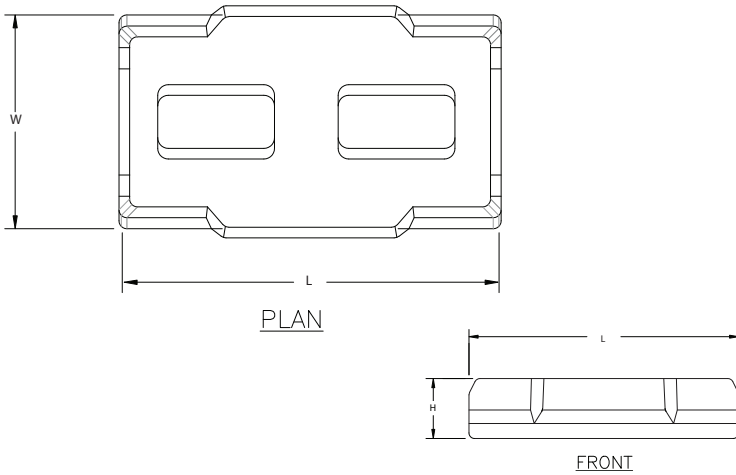

ArmorStone Unit Specification

CONCRETE BLOCK CLASS		NOMINAL DIMENSIONS (IN.)			UNIT COVERAGE (SF)	BLOCK		OPEN AREA %
		L	W	H		UNIT WEIGHT LBS.	SYSTEMS WEIGHTS LBS./SF	
AS 40	Open	18.00	10.00	4.50	1.25	50-54	40-44	25
AS 55	Closed	18.00	10.00	4.50	1.25	61-66	49-53	5

ArmorRoad® (not to scale)

ArmorRoad Unit Specification

BLOCK	TYPE	L	W	H	SF COVERAGE PER UNIT	WEIGHT LBS PER UNIT	SF PER TRUCK LOAD
Mat	Closed	18.00	15.60	6.00	1.74	105-109	750
Individual	Closed	18.00	15.60	6.00	1.74	100-104	750

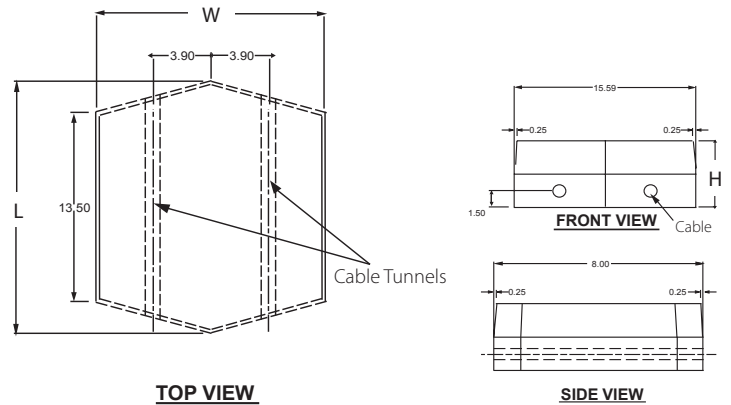

Armortec Minimum Physical Requirements per ASTM 06684-04

MIN. DENSITY (IN AIR) LBS/FT ³		MIN. COMPRESSIVE STRENGTH PSI		MAX WATER ABSORPTION LBS/FT ³	
Ave. of 3 Units	Individual Unit	Ave. of 3 Units	Individual Unit	Ave. of 3 Units	Individual Unit
130	125	4,000	3,500	9.1	11.7

Habitat Impairment Test

Kingston- Poughkeepsie Deepwater River Significant Coastal Fish and Wildlife Habitat

1 Introduction

The Central Hudson Gas & Electric Corporation (CHGE) former North Water Street manufactured gas plant (MGP) site is located at 2 Dutchess Avenue in the City of Poughkeepsie, Dutchess County, New York (Figure 1). The site is bounded by Dutchess Avenue to the north, North Water Street and Amtrak railroad lines to the east, the City of Poughkeepsie Upper Landing Park and Fall Kill Creek to the south, and the Hudson River to the west. Tidal movements affect the Hudson River adjacent to the site. Depths in the river within the project area are generally over 40 feet deep (Figure 2).

The site was operated as a carbureted water gas MGP from 1911 to 1950. CHGE has owned the site since 1926. During peak operation, waste by-products were recycled at the site, and during this process, by-products were reported to have seeped into the Hudson River from unintentional spills near the tar separator. To prevent additional seepage of by-products into the river, a clay dike was installed between the railroad siding and the river in the 1940s. Today, residuals from these releases are in the form of non-aqueous phase liquid (NAPL); more specifically dense non-aqueous phase liquid (DNAPL) is the primary form of site contamination to be addressed.

Of the remedial activities listed above, the dredging and capping activities in the Hudson River and along the river side slope are subject to Nationwide Permit (NWP) 38 and described here. Approximately 7.6 acres of dredging would be conducted to remove approximately 40,000 cubic yards (CYs) of sediment impacted by the operation of the former MGP facility (Figure 3). Dredging of the contaminated sediments that are visually impacted with NAPL are anticipated to be conducted between October 2018 through February 2019. Of the 40,000 CYs to be dredged, approximately 20,000 CYs will be removed in a 4 acre area of the Kingston-Poughkeepsie Deepwater Habitat, Significant Coastal Fish and Wildlife Habitat.

Dredging will be conducted using an environmental bucket within a containment cell mounted to the dredge, which will be outfitted with turbidity curtains and floating booms on all sides to control the transport of contaminated sediment beyond the dredging area. Figure 4 shows the curtain detail of the containment cell. Water quality (turbidity) will be monitored for the duration of the dredging by means of three buoy-mounted remote sensing stations that will be moored around the perimeter of the work area.

Dredged areas deeper than 2 feet below the existing bathymetry will then be backfilled after dredging with certified clean sand (approximately 31,000 CYs) imported from upland sources and transported to the site via barge to support restoration of the river bottom to pre-dredge bathymetry. The clean sand will be placed on approximately 4.2 acres of the dredged areas using specially-fabricated conveyors and tremie technology that will discharge backfill material from a tremie pipe above the dredge surface as deep as possible.

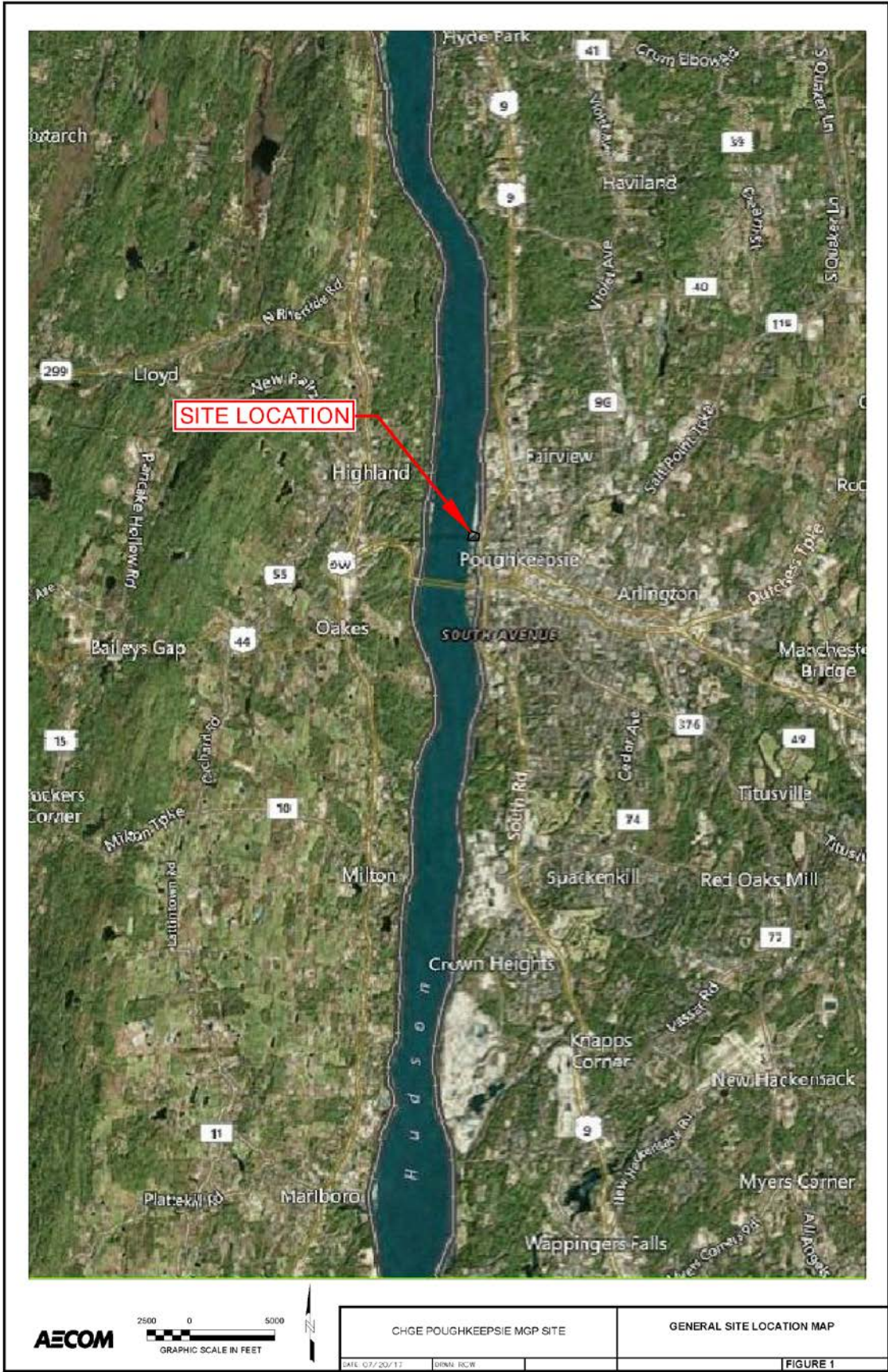

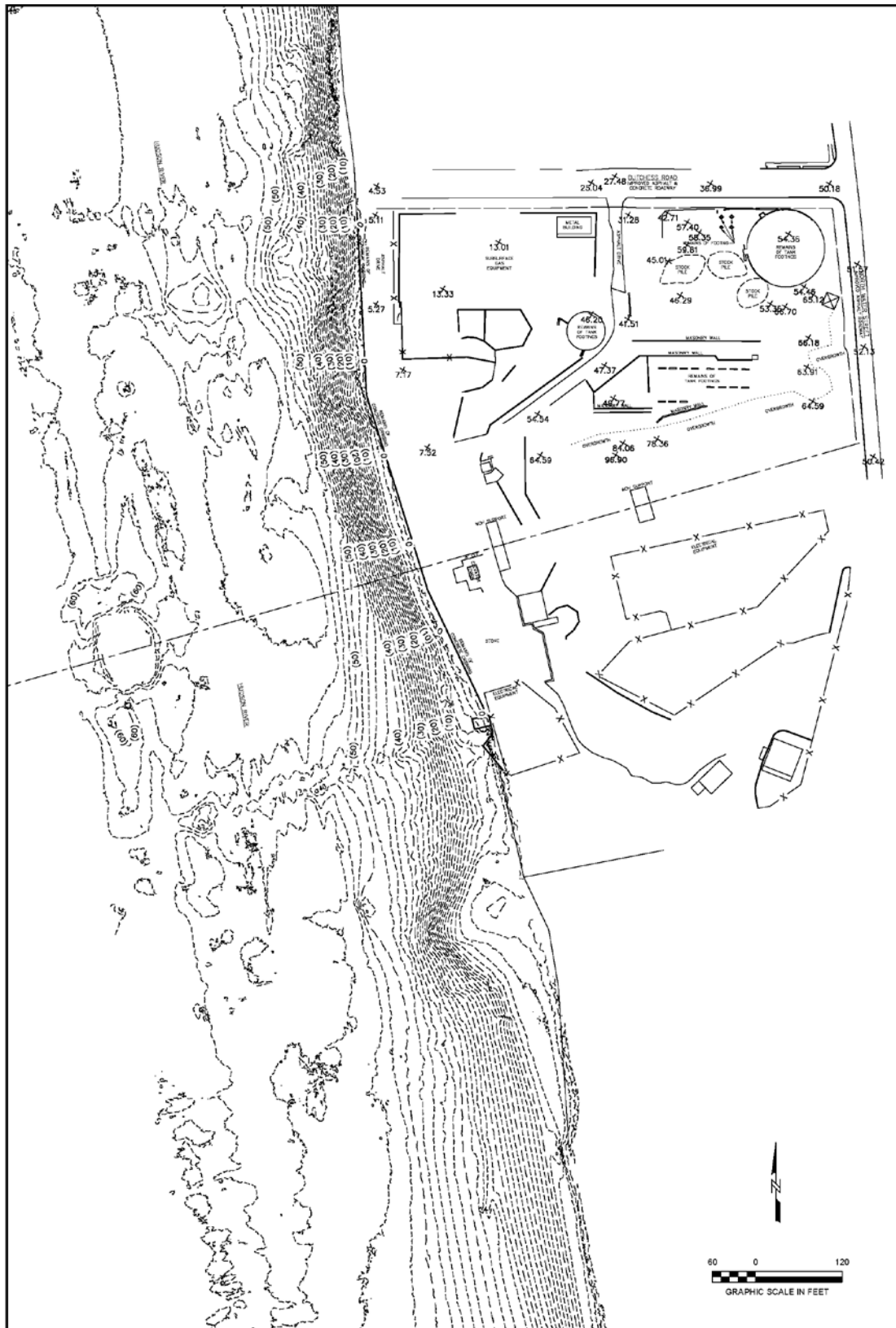

AECOM

CHGE POUGHKEEPSIE MGP SITE

SITE LAYOUT / EXISTING CONDITIONS

DATE 07/20/17

DRAWN RCW

FIGURE 2

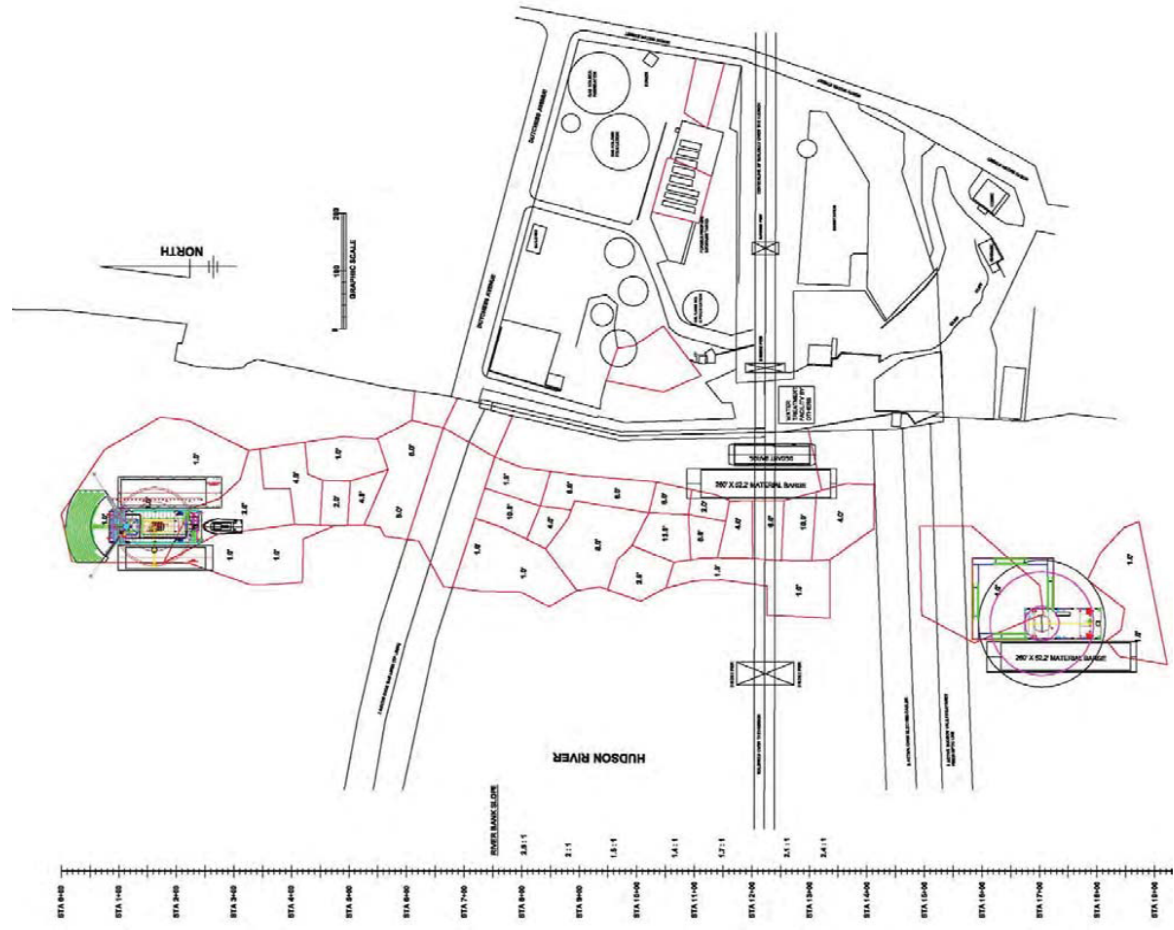

CHGE POUGHKEEPSIE MGP SITE
REMEDIAL ACTION RFP

DREDGE PLAN

DATE: 12/06/16

FIGURE 3

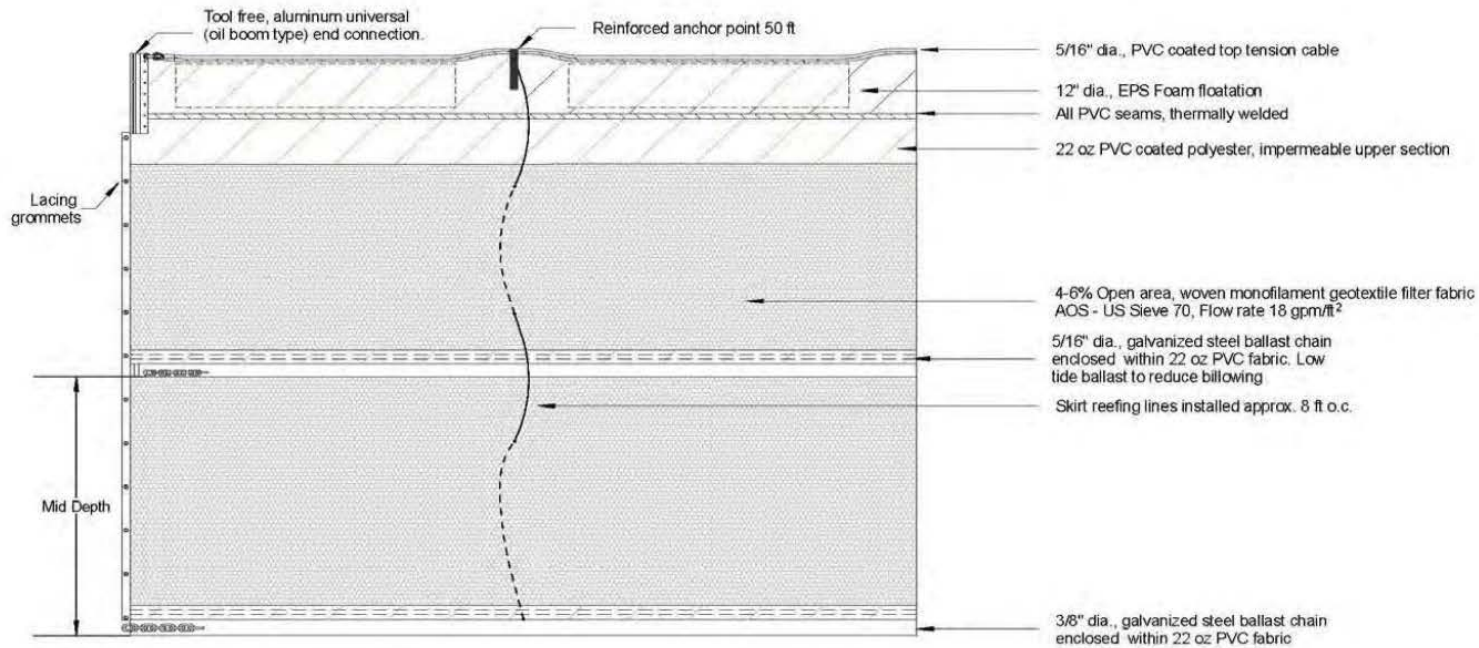
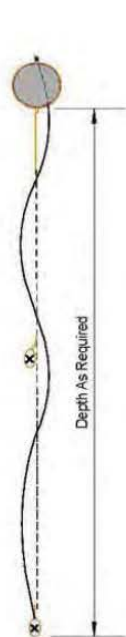

TURBIDITY BARRIER DETAIL
N.T.S.



CHGE POUGHKEEPSIE MGP SITE
REMEDIAL ACTION RFP

DATE: 12/06/16

CURTAIN DETAIL

FIGURE 4

The backfill will consist of clean sand, a granular material of sufficient size and density that it is expected to fall to the river bottom at its placement location with minimal dispersion. Clean sand was selected specifically to maximize accuracy of the fill placement operation and minimize suspension and transport of backfill material outside of the intended placement location to help restore the bottom contours to pre-dredging conditions.

The river bottom will be allowed to reestablish its original (pre-dredging) bathymetry within dredged areas by natural sediment transport processes to a depth of up to two feet. Sediment deposition and subsequent erosion is a natural cycle within a stable riverbed; while specific rates of sedimentation and erosion in the vicinity of Poughkeepsie are not available, sedimentation rates of approximately 40 centimeters (1.3 feet) within a period of months (typically, during the spring freshet) are observed within the Lower Hudson River as a whole, based on literature review. Excavations that depress portions of the river bottom below the surrounding bathymetry also function as natural sediment traps; consequently, it is expected that sediment transport within the dredged areas will be depositional only in nature until the pre-existing stable bathymetry is restored, after which the natural long-term deposition and erosion cycle will resume.

Review of the New York State Department of State Significant Coastal Fish and Wildlife Habitats (SCFWH) Maps indicates that dredging will occur within approximately four acres of the 6,350-acre Kingston-Poughkeepsie Deepwater River (NYSDOS, 2012). The significant habitat area is a nearly continuous deepwater section of the river ranging in water depth from 20 feet to 50 feet or greater.

2 Habitat Impairment Test

A habitat impairment test must be met for any activity that is subject to consistency review under federal and state laws, or under applicable local laws contained in an approved local waterfront revitalization program. If the proposed action is subject to consistency review, then the habitat protection policy applies, whether the proposed action is to occur within or outside the designated area. The specific habitat impairment test that must be met is as follows.

In order to protect and preserve a significant habitat, land and water uses or development shall not be undertaken if such actions would destroy the habitat or significantly impair the viability of a habitat.

- **Destroy the habitat** – Habitat destruction is defined as the loss of fish or wildlife use through direct physical alteration, disturbance, or pollution of a designated area or through the indirect effects of these actions on a designated area. Habitat destruction may be indicated by changes in vegetation, substrate, or hydrology, or increases in runoff, erosion, sedimentation, or pollutants.
- **Significantly Impair The Viability Of A Habitat** - Significant impairment is defined as reduction in vital resources (e.g., food, shelter, living space) or change in environmental conditions (e.g., temperature, substrate, salinity) beyond the tolerance range of an organism. Indicators of a significantly impaired habitat focus on ecological alterations and may include but are not limited to reduced carrying capacity, changes in community structure (food chain relationships, species diversity), reduced productivity and/or increased incidence of disease and mortality.

3 Impact Assessment

As per the NYSDOS' *Coastal Fish & Wildlife Habitat Rating Form* for the Kingston-Poughkeepsie Deepwater Habitat, the following potentially adverse activities and impacts should be considered in applying the habitat impairment test to a proposed activity.

1. Any activity that would substantially degrade water quality, increase turbidity or sedimentation, alter flows, salinity, or temperature, reduce water depths, or degrade or alter benthic communities in Kingston-Poughkeepsie Deepwater would result in significant impairment of the habitat. All species may be affected by water pollution, such as chemical contamination (including food chain effects resulting from bioaccumulation), oil spills, excessive turbidity or sediment loading, nonpoint source runoff, and waste disposal (including vessel wastes). Discharges or runoff of sewage effluent, pesticides, or other hazardous materials into the river may result in adverse impacts on the habitat area.
2. Any physical alteration of the habitat through dredging or filling (including dredge spoil disposal), would result in a direct loss of valuable habitat. Such activities could have significant impacts on striped bass and sturgeon populations during spawning, and incubation periods (May-July, primarily) and overwintering times. Habitat disturbances would be most detrimental during fish spawning and nursery periods, which generally extend from April through August for most warm water species.
3. Thermal impacts could have adverse effects on use of the area by migratory and resident species. Activities that result in the presence of significant electric, or magnetic, or electromagnetic field may affect benthic communities, migratory fish movement, and fish egg and larval development. Entrainment and impingement causes significant mortality to all life stages of fish, including endangered species. Activities that would enhance migratory, spawning, or nursery fish habitat, particularly where an area is essential to a species' life cycle or helps to restore an historic species population would be beneficial.

Dredging activities within the SCFWH area are limited to approximately 20,000 CYs within approximately four acres. Turbidity beyond the dredging area will be controlled by using an environmental bucket within a containment cell which will be outfitted with turbidity curtains that extend to the river bottom and floating booms on all sides. In addition, because dredging activities are anticipated to be conducted between October and February, disturbances during spawning, incubation, and nursing periods are unlikely to occur. Less intrusive capping activities are proposed between July and September though the small footprint of these activities and non-intrusive nature are not anticipated to have any adverse effects. Temporary water quality impacts from an increase in turbidity and/or sedimentation may occur during dredging activities but will be minor and short term. Moreover, the removal of sediments known to contain potentially ecologically-threatening constituents would provide long-term benefits to the fauna of the deepwater habitat which transit through the Hudson River.

3.1 Endangered Species Overwintering, Spawning, and Foraging Habitat

The Kingston-Poughkeepsie Deepwater Habitat is one of the largest and most well-known spawning areas for Atlantic sturgeon (*Acipenser oxyrinchus*) and overwintering areas for shortnose sturgeon (*Acipenser*

brevirostrum) in the Hudson River. Although habitat requirements of both sturgeon species are still being studied, it is believed that these deepwater areas may be critical year round. Yolk-sac larvae, suspected to be Atlantic sturgeon, have been collected from this region at depths of 45 feet to 120 feet. Mature Atlantic sturgeon have been routinely captured in deep water on both sides of the river near the middle and near the southern end of the habitat area. Spawning also occurs in deep water along the southern east shore of the river. Shortnose sturgeon use the portion of the river that generally is greater than 30 feet in depth. The majority of both Atlantic sturgeon and shortnose sturgeon taken for age-growth analysis during the biological survey in the 1930s came from within this habitat near Rhinecliff and Port Ewen. The Kingston- Poughkeepsie Deepwater Habitat also encompasses the reach of highest mean striped bass egg density from 1974-2006. Striped bass spawning over deepwater has been observed in this reach of the river.

Based on the Atlantic sturgeon and shortnose sturgeon life cycles, with regard to spawning habitat and overwintering areas, dredge work activities will be limited to the timeframe when these species are less likely to be present in the site area (October through February), to avoid the overwintering near Kingston and the migration to the spawning grounds. Moreover, given the size of the dredging area relative to the overall habitat, potential disruption to the Atlantic sturgeon and shortnose sturgeon is expected to be insignificant.

3.2 Deepwater Habitat

The Kingston-Poughkeepsie Deepwater Habitat is a nearly continuous deepwater section of the river, from a water depth of 20 feet to the bottom, and especially where water depths of 50 feet or greater occur. The Kingston-Poughkeepsie Deepwater Habitat is the northernmost extensive section of deepwater habitat in the Hudson River. Deepwater areas support a diversity of freshwater and migratory species in the Hudson River. In addition to Atlantic sturgeon and shortnose sturgeon, fish species found in this section of river include fourspine stickleback (*Apeltes quadracus*), hogchoker (*Trinectes maculatus*), killifish (*Fundulus diaphanous*), threespine stickleback (*Gasterosteus aculeatus*), white perch (*Morone americana*), bluegill (*Lepomis macrochirus*), brown bullhead (*Ameiurus nebulosus*), common carp (*Cyprinus carpio*), golden shiner (*Notemigonus crysoleucas*), largemouth bass (*Micropterus salmoides*), pumpkinseed (*Lepomis gibbosus*), smallmouth bass (*Micropterus dolomieu*), spottail shiner (*Notropis hudsonius*), white catfish (*Ameiurus catus*), yellow perch (*Perca flavescens*), alewife (*Alosa pseudoharengus*), American eel (*Anguilla rostrata*), American shad (*Alosa sapidissima*), blueback herring (*Alosa aestivalis*), and striped bass (*Morone saxatilis*). However, salinities within the project area are generally less than 5.0 parts per thousand, which would exclude the presence of many marine and estuarine species. Any impacts to deepwater habitat during construction activities is expected to be minor and temporary.

3.3 Blue Crab and Waterfowl Habitat

The Kingston-Poughkeepsie Deepwater Habitat area provides habitat for blue crab (*Callinectes sapidus*) and concentrations of waterfowl such as American black duck (*Anas rubripes*), blue-winged teal (*Anas discors*), common goldeneye (*Bucephala clangula*), common merganser (*Mergus merganser*), gadwall (*Anas strepera*), greater scaup (*Aythya marila*), green-winged teal (*Anas crecca*), hooded merganser (*Lophodytes cucullatus*), lesser scaup (*Aythya affinis*), mallard (*Anas platyrhynchos*), northern pintail (*Anas acuta*), red-breasted merganser (*Mergus serrator*), and wood duck (*Aix sponsa*). Shallow water

areas, protected inlets, marshes or other habitats favored by waterfowl do not occur within and/or immediately adjacent to the project area. Impacts to waterfowl habitat from dredging activities are not expected during the project.

Although some blue crab habitat disruption will occur during dredging activities, the long-term benefit will be gained by reducing areas of sediments known to contain potentially ecologically-threatening constituents. The dredging will occur only in a small portion of the deepwater habitat, allowing any affected organisms to temporarily relocate during project activities. It is anticipated that restoration of the dredged areas with clean backfill materials, along with natural sedimentation processes will allow for the re-colonization of organisms. The re-colonization within the dredge area substrates will provide benthic habitat and food sources. To further minimize the potential impacts of the remediation activities, the dredging will occur during times of the year when bottom feeders are unlikely to be present in the dredging area.

4 Conclusion

The dredging activities associated with this project would not result in long-term or permanent habitat destruction or significantly reduce the viability of the SCFWH. The limited and temporary disturbance of approximately four acres of the SCFWH, the timing of activities to protect species during critical life stages, and the use of BMPs would result in very minor and temporary ecological impacts.

In addition, the removal of toxins associated with NAPL-laden sediments would have positive long-term benefits for the habitat. Also, the placement of capping materials on the slope would increase benthic rugosity allowing for hard substrates to be colonized by sessile organisms and provided vertical relief for motile aquatic organisms to use as a habitat structure.

Appendix I

**United States Army Corps of Engineers Nationwide Permit No. 3 Joint
Application - SUBMITTED SEPTEMBER 2017**

E-Format Only

**Permit for Reference Only. Permit to be resubmitted as a combined
permit with Nationwide Permit No. 38 Joint Application in August
2018**



AECOM
125 Broad Street, 16th floor
New York, NY 10004
www.aecom.com

212.377.8400 tel
212.377.8410 fax

September 26, 2017

U.S. Army Corps of Engineers, New York District
Attn: Regulatory Branch – Mr. Brendan Newell
26 Federal Plaza
New York, NY 10278-0090

RE: Permit Application Number NAN-2017-00912-WNE
Authorization for coverage under Nationwide Permit 3, Maintenance
Central Hudson Gas & Electric
2 Dutchess Avenue
North Water Street, Poughkeepsie, New York

Dear Mr. Newell:

On behalf of Central Hudson Gas & Electric Corporation (CHGE), AECOM submits the attached application and supporting materials for United States Army Corps of Engineers (USACE) review of the activities associated with the replacement of the bulkhead at CHGE's North Water Street former Manufactured Gas Plant (MGP) site located in the city of Poughkeepsie, Dutchess County, New York and approval for the work to proceed under Nationwide Permit 3 (NWP3), if required.

Though AECOM believes a pre-construction notification (PCN) is not applicable for this project, the following presents the information that would ordinarily be included within a PCN and is included for your reference. Additional details are also presented within the NWP3 Joint Application Form (Attachment 1).

(1) Name, address, and telephone numbers of the prospective permittee;

Mark McLean
Central Hudson Gas & Electric Corporation
284 South Avenue
Poughkeepsie, New York 12601
845-486-5461

(2) Location of the proposed project;

2 Dutchess Avenue
Poughkeepsie, New York 12601

A Site Vicinity map is included in Attachment 2.

(3) A description of the proposed project; the project's purpose; direct and indirect adverse environmental effects the project would cause, including the anticipated amount of loss of water of the United States expected to result from the NWP activity, in acres, linear feet, or other appropriate unit of measure; any other NWP(s), regional general permit(s), or individual permit(s) used or intended to be used to authorize any part of the proposed project or any related activity. The description should be sufficiently detailed to allow the district engineer to determine that the adverse effects of the project will be minimal and to determine the need for compensatory mitigation. Sketches should be provided when necessary to show that the activity complies with the terms of the NWP. (Sketches usually clarify the project and when provided results in a quicker decision. Sketches should contain

sufficient detail to provide an illustrative description of the proposed activity (e.g., a conceptual plan), but do not need to be detailed engineering plans);

Project Site Location and Description

The project site is located on the eastern bank of the Hudson River at the intersection of North Water Street and Dutchess Avenue in Poughkeepsie, New York. CHGE owns the project site that is approximately 13 acres in size and is bounded by: the Hudson River to the west, Dutchess Avenue to the north, North Water Street and Amtrak railroad to the east and the City of Poughkeepsie Upper Landing Park and Fallkill Creek to the south. Currently, CHGE operates a natural gas regulator station on the northwest portion of the site and an electric transition and substation on the southern/eastern portion of the site. Most of the project site has a gravel cover or is paved.

Site Features

The upland portion of the project site consists of two relatively flat terraces, separated by steep, rocky slopes with very thin soil cover. The lower terrace lies on the banks of the Hudson River, roughly 5 to 10 feet above sea level. The upper terrace is roughly 50 feet higher, bordering North Water Street. The only building located at the project site is an unoccupied cinder block valve house associated with the natural gas regulator station.

Important and vital energy infrastructure is located on the project site. Both natural gas transmission pipelines and electric transmission lines cross beneath the Hudson River at this location, and connect with natural gas and electrical lines which serve much wider areas surrounding Poughkeepsie. An electrical transmission transition station is located on the lower terrace at the southwestern portion of the project site, where the electrical transmission line meets the shoreline. A natural gas regulator station occupies the northwestern corner of the lower terrace of the site where the natural gas transmission pipeline meets the shoreline. A fence encloses the transition and regulator stations.

Permit Activities

CHGE is requesting USACE's concurrence with the proposed work detailed below is authorized by Nationwide Permit #3 or confirmation that the planned work does not require specific authorization. The subject project entails the replacement of an existing, deteriorated timber bulkhead with a steel bulkhead. As previously described in our meeting on July 25, 2017, the existing timber bulkhead currently serves to hold back landward-side fill; the replacement bulkhead would be installed along or behind (landward) of alignment of the existing timber bulkhead, to a height varying between elevations 3.0 to 5.0 feet in the North American Vertical Datum of 1988 (NAVD88) (4.58 to 6.58 feet above Mean Low Water [MLW] or 1.07 to 3.07 feet above Mean Higher High Water [MHHW]). Future in-river remediation work to be the subject of a separate permit application notwithstanding, the approximately 850 linear feet of the existing deteriorated bulkhead must nevertheless be replaced to:

- Stabilize the existing shoreline;
- Protect critical natural gas and electric transmission infrastructure from being damaged during storm events; and
- Allow potential future construction, by others, of a walkway along the Hudson River shoreline.

The following construction sequence will be used to construct the replacement bulkhead:

- Portions of the existing wall timbers may be removed in advance to minimize obstructions that may interfere with the installation of the replacement bulkhead wall. A turbidity curtain will be placed around the work area and monitoring of the work area will be conducted.

- A variable moment vibratory hammer will be used to install PZC-18 sheets to specified depths, varying in relation to the top of bedrock along the replacement bulkhead alignment. Sheets are expected to be installed (see Attachment 2) over the 850-foot length of the replacement bulkhead wall, with depths of individual sheets ranging from approximately 20 to 55 feet. The alignment of the replacement bulkhead is depicted on Figure 2, attached.
- Permanent waler sections will be installed along the replacement bulkhead, and anchor rods will be installed in trenches at regular intervals to tie the replacement bulkhead to a deadman. The deadman will consist of a short (approximately 12 feet deep) sheetpile wall installed approximately 30 feet behind (landward) of the bulkhead, to provide structural stability. Cross-sections of the bulkhead and deadman arrangement are depicted on Figures 4 through 9, attached.
- Placement of approximately 0.1 acre of material behind the newly constructed steel bulkhead to stabilize the shoreline. The calculation sheet for determining the material is included in Attachment 2. The material will consist of an armor layer from an upland source. The armor layer will consist of 6-inch minus (d50 = 4 inch, minimum size = 1 inch) washed stone, river rock, gravel, and/or cobbles, containing no debris or organic material.

(4) The PCN must include a delineation of wetlands, other special aquatic sites, and other waters, such as lakes and ponds, and perennial, intermittent, and ephemeral streams, on the project site. Wetland delineations must be prepared in accordance with the current method required by the Corps. The permittee may ask the Corps to delineate the special aquatic sites and other waters on the project site, but there may be a delay if the Corps does the delineation, especially if the project site is large or contains many waters of the United States. Furthermore, the 45-day period will not start until the delineation has been submitted to or completed by the Corps, as appropriate;

According to the NYSDEC Freshwater Wetlands Map for Dutchess County, there are no state wetlands located within a 2-mile radius of the site.

The National Wetlands Inventory (NWI) Map for Dutchess County identifies numerous wetlands within a 2-mile radius of the site, including palustrine emergent, scrub-shrub and forested wetlands and riverine wetlands, but no wetlands (with the exception of the Hudson River) are located in close proximity to the site. The NWI wetland maps are generated by the U.S. Fish and Wildlife Service (USFWS) using stereoscopic analysis of high-altitude aerial photographs, and the majority of the mapped wetlands are not field verified.

(5) If the proposed activity will result in the loss of greater than 1/10-acre of wetlands and a PCN is required, the prospective permittee must submit a statement describing how the mitigation requirement will be satisfied, or explaining why the adverse effects are minimal and why compensatory mitigation should not be required. As an alternative, the prospective permittee may submit a conceptual or detailed mitigation plan.

The proposed activity will take place along or landward side of the existing timber bulkhead. As such, the proposed activity will not result in the loss of greater than 1/10-acre of waters of the United States. Any adverse effects will be minimal and compensatory mitigation should not be required.

(6) If any listed species or designated critical habitat might be affected or is in the vicinity of the project, or if the project is located in designated critical habitat, for non-Federal applicants the PCN must include the name(s) of those endangered or

threatened species that might be affected by the proposed work or utilize the designated critical habitat that may be affected by the proposed work. Federal applicants must provide documentation demonstrating compliance with the Endangered Species Act;

There are no listed species or critical habitats that might be affected by the project. The project is not located in designated critical habitat.

The section of the Hudson River adjacent to the site is part of the Hudson River Estuary Program, which was created in 1987 by the NYSDEC. In coordination with state and federal agencies and public-private partnerships, this watershed protection program focuses on natural resource conservation and protection. Various species of fish are present within the river, including migratory species such as the American shad, striped bass, river herring, blue crab, and the Atlantic sturgeon (NYSDEC, 2017a).

Threatened/Endangered Species and Significant Habitat

A request for threatened/endangered species information was submitted to the NYSDEC Natural Heritage Program (NHP) on June 29, 2010 by Arcadis to inquire about the potential presence of sensitive species or habitats in the vicinity of the site. According to the NYSDEC response dated July 13, 2010, several species were recorded as occurring within the vicinity of the site. Specifically, the peregrine falcon (*Falco peregrinus* – state endangered), shortnose sturgeon (*Acipenser brevirostrum* – state endangered), false hop sedge (*Carex lupuliformis* – rare), and Virginia snakeroot (*Endodeca serpentaria* – state endangered) exist in the vicinity of the site (NYSDEC, 2010).

Peregrine falcons have been recorded as nesting on the Mid-Hudson Bridge that runs between Poughkeepsie and Highland (NYSDEC, 2017b). However, the site itself does not provide suitable habitat for the peregrine falcon (e.g., tall buildings for nesting).

The shortnose sturgeon may be present in the portion of the Hudson River adjacent to the site, though are not believed to be present temporally during the proposed construction timeframe.

The two vascular plants (false hop sedge and Virginia snakeroot) were recorded as occurring in Ulster County in the Mid-Hudson Woods, near the west shore of the Hudson River and as such, are not expected to be present at the site.

Historical records (pre-1979) indicate the potential presence of other threatened/endangered plants in Ulster County (i.e., straw sedge [*Carex straminea*], golden corydalis [*Corydalis aurea*], velvety bush clover [*Lespedeza stuevei*], and heartleaf plantain [*Plantago cordata*]), although these plants would not be expected to be present at the site. Golden club (*Orontium aquaticum*) was historically recorded (ca. 1869) as occurring in Dutchess County in the City of Poughkeepsie; however, this plant species was not observed as occurring at the site.

According to the NYSDEC (2010a), the site is adjacent to a designated Significant Coastal Fish and Wildlife Habitat (i.e., Hudson River), which is part of New York State's Coastal Management Program.

Information on federally-listed threatened/endangered species for Dutchess County was obtained on-line through the USFWS website (specifically the USFWS Northeast Field Office). Based on available information for Dutchess County, the bald eagle (*Haliaeetus leucocephalus* – federally delisted, but still protected under the Bald and Golden Eagle Protection Act), Indiana bat (*Myotis sodalis* – federally endangered), Northern long-eared bat (*Myotis septentrionalis* – federally threatened), Atlantic sturgeon (*Acipenser oxyrinchus oxyrinchus* – federal endangered), shortnose sturgeon (federally endangered), bog turtle (*Clemmys mühlenbergii* – federally threatened), dwarf wedgemussel (*Alasmidonta heterodon* – federally endangered), and New England cottontail (*Sylvilagus transitionalis* – federal candidate species) are known or likely to occur within this county

(USFWS, 2015). The USFWS generally recommends an evaluation of site habitat and consultation with the NYSDEC NHP to evaluate the potential presence of threatened/endangered species in the vicinity of the site (see above).

The habitat requirements of the bald eagle are undisturbed areas near large lakes and reservoirs, marshes and swamps, or stretches along rivers where they can find open water with suitable fisheries (NYSDEC, 2017c). Although the site is adjacent to the Hudson River, the site itself is highly disturbed and cleared of most vegetation, and is not believed to provide bald eagle habitat.

The habitat requirements of the Indiana bat and Northern long-eared bat are wintering locations such as caves and mines in which they hibernate, and summer locations consisting of surrounding areas for breeding and feeding on flying insects. During the summer, northern long-eared bats roost singly or in colonies underneath bark, in cavities or in crevices of both live trees and snags (dead trees). Males and non-reproductive females may also roost in cooler places, like caves and mines. There are eight hibernacula currently known in New York State in Albany, Essex, Warren, Jefferson, Onondaga and Ulster Counties (NYSDEC, 2017d); the site is not among the known hibernacula. In addition, potential impacts to these species will be avoided by cutting trees in December when the bats are not using them.

The habitat requirements for the bog turtle are generally slow, shallow, muck-bottomed rivulets of sphagnum bogs, calcareous fens, marshy/sedge-tussock meadows, spring seeps, wet cow pastures, and shrub swamps; suitable habitat generally contains sedges and/or mossy cover (NatureServe, 2017).

The New England cottontail generally prefers early successional forests (i.e., thickets) with dense undergrowth (USFWS, 2006). Suitable habitat for these upland species does not exist at the site or within the immediate vicinity of the site.

The dwarf wedgemussel is a freshwater mussel and preferred habitat generally includes running waters of all sizes, from small brooks to large rivers with substrates consisting of sand, silt, and gravel (NYSDEC, 2017e). Because this mussel is a freshwater species and the portion of the Hudson River adjacent to the site is tidal, this aquatic species is not expected to occur near the site.

Atlantic Sturgeon adults likely spawn downstream closer to the salt front during April and spend more time in coastal waters at other times of the year, while Shortnose Sturgeon move upstream for spawning in early April. Spawning has been documented as occurring from Coeymans to Troy Dam (River Mile 132-152) approximately 60 miles upstream of the site. Hence, it is not likely that sturgeon will be in the area of bulkhead replacement in winter. If there is sturgeon in the area, the sheet pile installation techniques described below for the replacement bulkhead will further reduce any potential effects.

The sheet pile driving and installation is not likely to adversely affect Atlantic Sturgeon and Shortnose Sturgeon due to the location of and short duration required for the bulkhead installation. The installation of the permanent sheet pile replacement bulkhead will be conducted over a short time period (approximately 8 work weeks) during winter. The bulkhead will be located at the shore (landward of the existing deteriorated bulkhead), which will not impede potential sturgeon movement upstream. To reduce potential sonic effects on sturgeon, steel sheets will be installed using vibratory methods (e.g., variable momentum vibratory hammer) that eliminate sharp, sound pressure-peak impacts to aquatic biota. These methods use a variable moment hammer which counter balances the eccentrics that are associated with the initial start-up of a hammer and provide vibration free start-up and shut down. Vibrations are also reduced as the sheets are vibrated further into the ground, which further limits the temporal extent of potential disturbance. The equipment used to install the sheet sheets utilizes variable moment vibration allowing for sheets to advance without the eccentric force that is typically generated by the initial startup and shut down of a suspended impact hammer-type installation.

(7) For an activity that may affect a historic property listed on, determined to be eligible for listing on, or potentially eligible for listing on, the National Register of Historic Places, for non-Federal applicants the PCN must state which historic property may be affected by the proposed work or include a vicinity map indicating the location of the historic property. Federal applicants must provide documentation demonstrating compliance with Section 106 of the National Historic Preservation Act.

The property is not an historic property, although it is located beneath the Poughkeepsie Walkway Bridge and about 200 feet southwest of the Hoffman Home and Grounds which are listed on the National Registry of Historic Places. The project activity will not have any impact on either of the listed properties. The property is not eligible for listing on, or potentially eligible for listing on, the National Register of Historic Places. A Section 106 Consultation letter and relevant CRIS search results were submitted to the New York State Office of Parks, Recreation and Historic Preservation (NYS OPRHP) office. The results of the OPRHP consultation conclude that there is no impact from the replacement activities.

To facilitate your review, the following items are enclosed, as required by the general and regional conditions for NWP3:

- Site information relevant to a pre-construction notification (this letter);
- Nationwide Permit 3 Joint Application Form (Attachment 1);
- Site Vicinity Plan, Design Drawings including Plan View and Elevation View (Attachment 2);
- A completed Essential Fish Habitat (EFH) Worksheet and Correspondence with NOAA/National Marine Fisheries Service, Mid-Atlantic Office (Attachment 3);
- A completed 2017 NLAA Program Verification Form (Attachment 4); and
- Supporting information regarding cultural resources from the New York State Historic Preservation Office (Attachment 5).

Please note that the work will be completed landward of the existing bulkhead and as such completed Environmental Questionnaire or a NYS Department of State Federal Consistency Assessment Form are not required or included with this package.

If you have any questions regarding this application or the attachments, please do not hesitate to contact me at (212) 377-8708 or shail.pandya@aecom.com.

Sincerely,



Shail Pandya
Sr. Project Manager
AECOM

cc: Mark McLean – CHGE
Wayne Mancroni – CHGE
Jesse Gallo – CHGE
Michael Spera, PE – AECOM

Enc.

References

- NatureServe. 2017. Species profile on bog turtle (*Glyptemys muhlenbergii*). Available at http://explorer.natureserve.org/servlet/NatureServe?sourceTemplate=tabular_report.wmt&loadTemplate=species_RptComprehensive.wmt&selectedReport=RptComprehensive.wmt&summaryView=tabular_report.wmt&elKey=101495&paging=home&save=true&startIndex=1&nextStartIndex=1&reset=false&offPageSelectedElKey=101495&offPageSelectedElType=species&offPageYesNo=true&post_processes=&radiobutton=radiobutton&selectedIndexes=101495. Updated November 2016.
2010. Letter to Serese Marotta, ARCADIS, from Tara Salerno, NYSDEC, regarding the potential presence of threatened/endangered species or significant habitat near the North Water Street site. Dated July 13, 2010.
- NYSDEC. 2017a. Hudson River Estuary Program. 2016 Coordinator's Annual Report to Hudson River Estuary Management Advisory Committee (HREMAC).
- NYSDEC. 2017b. Peregrine Falcon Information for the Mid-Hudson Bridge. Available at <http://www.dec.ny.gov/animals/34268.html>.
- NYSDEC. 2017c. Bald Eagle Fact Sheet. Available at <http://www.dec.ny.gov/animals/74052.html>.
- NYSDEC. 2017d. Indiana Bat Fact Sheet. Available at <http://www.dec.ny.gov/animals/6972.html>.
- NYSDEC. 2017e. Dwarf Wedgemussel Fact Sheet. Available at <http://www.dec.ny.gov/animals/42253.html>.
- USFWS. 2006. Species profile for New England cottontail. Available at <http://www.fws.gov/northeast/pdf/necotton.fs.pdf>. August. USGS, 2006. www.waterdata.usgs.gov/ny/nwis, USGS Station 01372058.
- USFWS. 2015. Federally-listed species in New York State (revised February 13, 2015). Available at <http://www.fws.gov/northeast/nyfo/es/ColistCurrent.pdf>.

Attachment 1

Nationwide Permit 3 (NWP3)
Joint Application Form



JOINT APPLICATION FORM

For Permits for activities affecting streams, waterways, waterbodies, wetlands, coastal areas, sources of water, and endangered and threatened species.

You must separately apply for and obtain Permits from each involved agency before starting work. Please read all instructions.

1. Applications To:
>NYS Department of Environmental Conservation
Check all permits that apply: Stream Disturbance, Dams and Impoundment Structures, Tidal Wetlands, Water Withdrawal, etc.
>US Army Corps of Engineers
Check all permits that apply: Section 404 Clean Water Act, Section 10 Rivers and Harbors Act
>NYS Office of General Services
Check all permits that apply: State Owned Lands Under Water, Utility Easement, Docks, Moorings or Platforms
>NYS Department of State
Check if this applies: Coastal Consistency Concurrence

2. Name of Applicant
Taxpayer ID (if applicant is NOT an individual)
Mailing Address
Post Office / City, State, Zip
Telephone, Email
Applicant Must be (check all that apply): Owner, Operator, Lessee

3. Name of Property Owner (if different than Applicant)
Mailing Address
Post Office / City, State, Zip
Telephone, Email

For Agency Use Only Agency Application Number:

4. Name of Contact / Agent

Mailing Address _____ Post Office / City _____ State _____ Zip _____

Telephone _____ Email _____

5. Project / Facility Name _____ Property Tax Map Section / Block / Lot Number: _____

Project Street Address, if applicable _____ Post Office / City _____ State _____ Zip _____

_____ NY _____

Provide directions and distances to roads, intersections, bridges and bodies of water

Town Village City County _____ Stream/Waterbody Name _____

Project Location Coordinates: Enter Latitude and Longitude in degrees, minutes, seconds:

Latitude: _____° _____' _____" Longitude: _____° _____' _____"

6. Project Description: Provide the following information about your project. Continue each response and provide any additional information on other pages. **Attach plans on separate pages.**

a. Purpose of the proposed project:

b. Description of current site conditions:

c. Proposed site changes:

d. Type of structures and fill materials to be installed, and quantity of materials to be used (e.g., square feet of coverage, cubic yards of fill material, structures below ordinary/mean high water, etc.):

e. Area of excavation or dredging, volume of material to be removed, location of dredged material placement:

f. Is tree cutting or clearing proposed? Yes If Yes, explain below. No

Timing of the proposed cutting or clearing (month/year): _____

Number of trees to be cut: _____ Acreage of trees to be cleared: _____

g. Work methods and type of equipment to be used:

h. Describe the planned sequence of activities:

i. Pollution control methods and other actions proposed to mitigate environmental impacts:

j. Erosion and silt control methods that will be used to prevent water quality impacts:

k. Alternatives considered to avoid regulated areas. If no feasible alternatives exist, explain how the project will minimize impacts:

l. Proposed use: Private Public Commercial

m. Proposed Start Date: Estimated Completion Date:

n. Has work begun on project? Yes If Yes, explain below. No

o. Will project occupy Federal, State, or Municipal Land? Yes If Yes, explain below. No

p. List any previous DEC, USACE, OGS or DOS Permit / Application numbers for activities at this location:

q. Will this project require additional Federal, State, or Local authorizations, including zoning changes?

Yes If Yes, list below. No

7. Signatures.

Applicant and Owner (If different) must sign the application.

Append additional pages of this Signature section if there are multiple Applicants, Owners or Contact/Agents.

I hereby affirm that information provided on this form and all attachments submitted herewith is true to the best of my knowledge and belief.

Permission to Inspect - I hereby consent to Agency inspection of the project site and adjacent property areas. Agency staff may enter the property without notice between 7:00 am and 7:00 pm, Monday - Friday. Inspection may occur without the owner, applicant or agent present. If the property is posted with "keep out" signs or fenced with an unlocked gate, Agency staff may still enter the property. Agency staff may take measurements, analyze site physical characteristics, take soil and vegetation samples, sketch and photograph the site. I understand that failure to give this consent may result in denial of the permit(s) sought by this application.

False statements made herein are punishable as a Class A misdemeanor pursuant to Section 210.45 of the NYS Penal Law. Further, the applicant accepts full responsibility for all damage, direct or indirect, of whatever nature, and by whomever suffered, arising out of the project described herein and agrees to indemnify and save harmless the State from suits, actions, damages and costs of every name and description resulting from said project. In addition, Federal Law, 18 U.S.C., Section 1001 provides for a fine of not more than \$10,000 or imprisonment for not more than 5 years, or both where an applicant knowingly and willingly falsifies, conceals, or covers up a material fact; or knowingly makes or uses a false, fictitious or fraudulent statement.

Signature of Applicant

Date

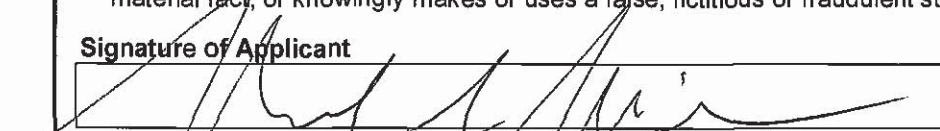

9/26/17

Applicant Must be (check all that apply): Owner Operator Lessee

Printed Name

Title

Mark McLean, Central Hudson Gas and Electric Corp

Senior Project Manager

Signature of Owner (if different than Applicant)

Date

Printed Name

Title

Signature of Contact / Agent

Date



9/26/17

Printed Name

Title

Shail Pandya, AECOM

Senior Project Manager

For Agency Use Only

DETERMINATION OF NO PERMIT REQUIRED

Agency Application Number

(Agency Name) has determined that No Permit is required from this Agency for the project described in this application.

Agency Representative:

Printed Name

Title

Signature

Date

Attachment 2

Site Vicinity Plan, Design Drawings including
Plan View and Elevation View

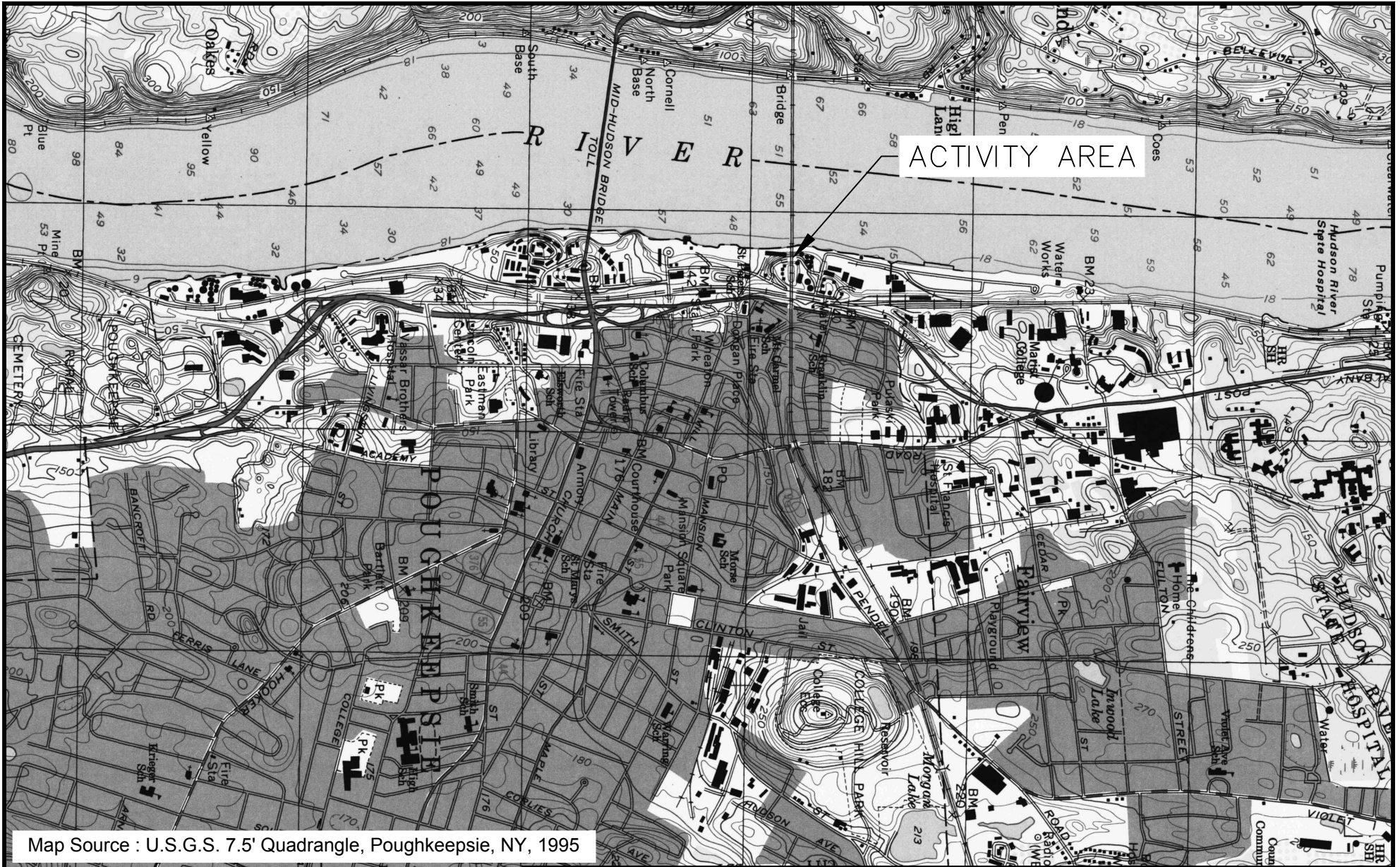

Map Source : U.S.G.S. 7.5' Quadrangle, Poughkeepsie, NY, 1995

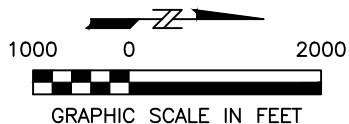

CENTRAL HUDSON GAS & ELECTRIC
DUTCHESS COUNTY, NY

NAN-2017-00912-WNE

DATE: 09/20/17

PROPOSED STEEL BULKHEAD
VICINITY MAP

FIGURE 1 OF 9

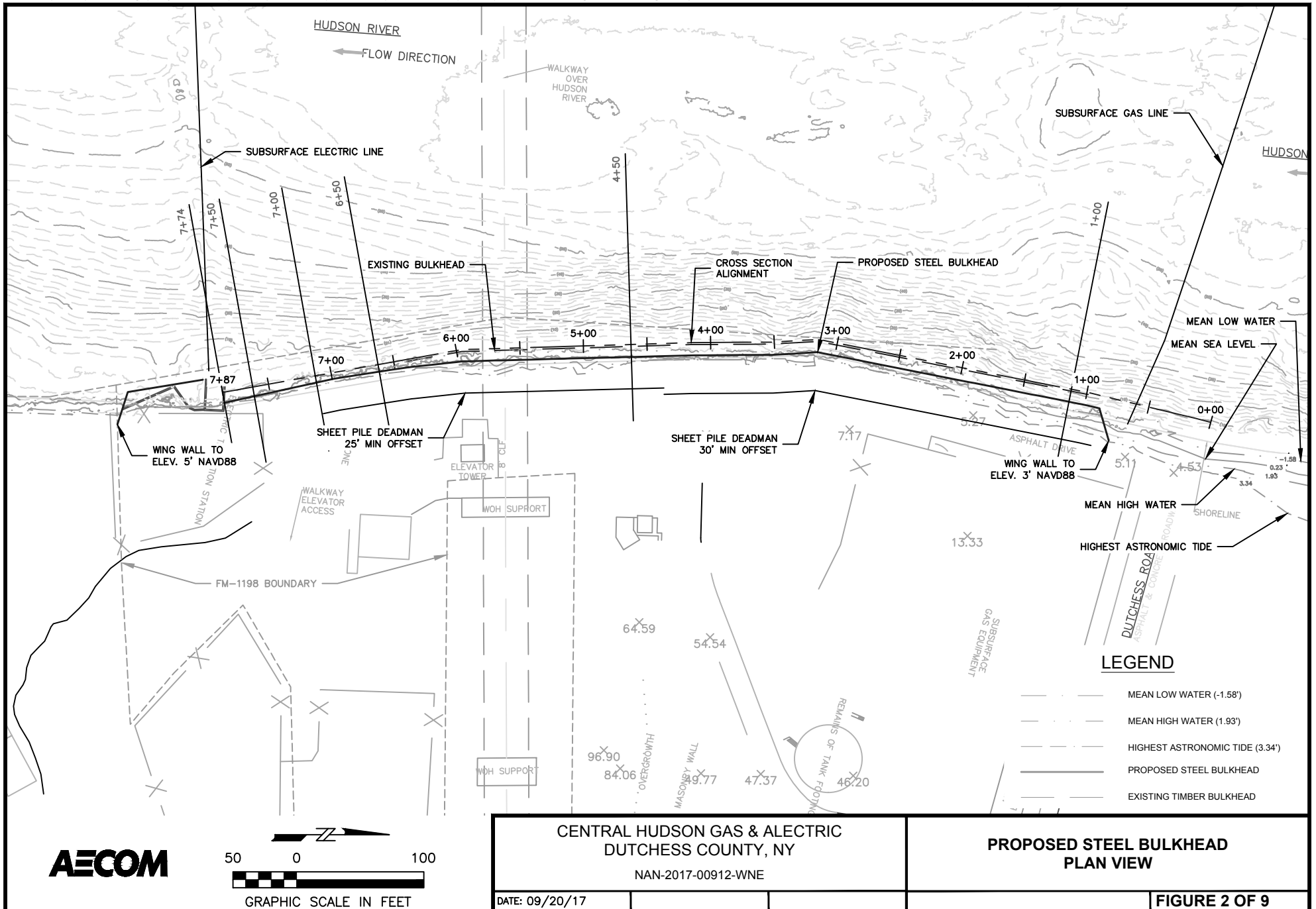

AECOM

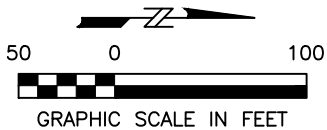

CENTRAL HUDSON GAS & ELECTRIC
DUTCHESS COUNTY, NY
NAN-2017-00912-WNE

DATE: 09/20/17

**PROPOSED STEEL BULKHEAD
PLAN VIEW**

FIGURE 2 OF 9

PROPOSED STEEL BULKHEAD

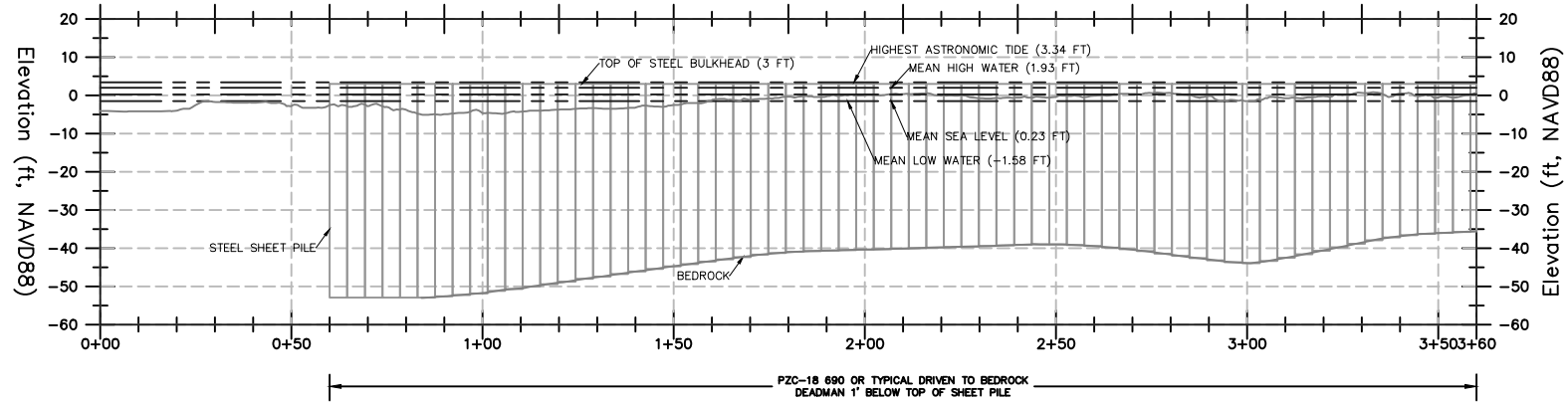

PROPOSED STEEL BULKHEAD

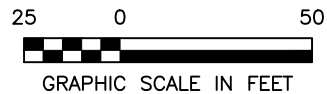
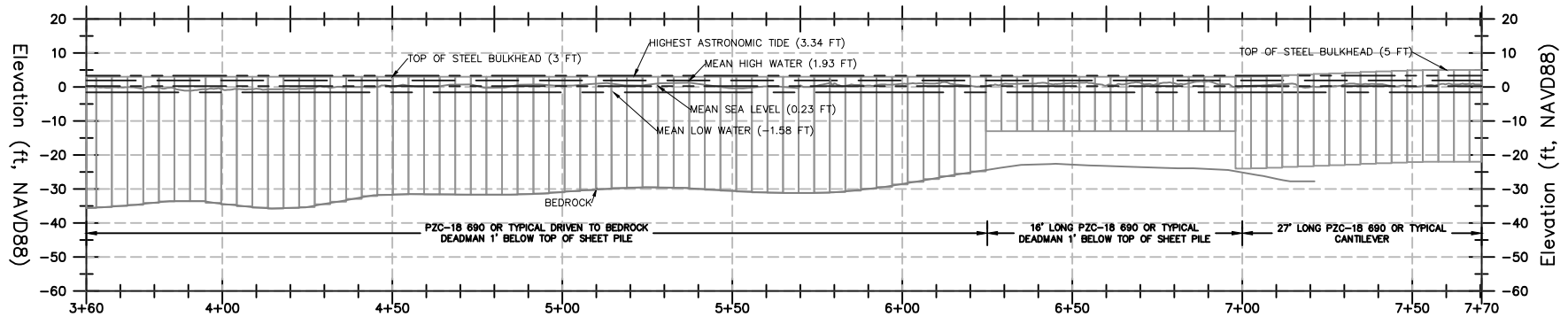

CENTRAL HUDSON GAS & ELECTRIC
DUTCHESS COUNTY, NY

NAN-2017-00912-WNE

DATE: 09/20/17

PROPOSED STEEL BULKHEAD
PROFILE VIEW

FIGURE 3 OF 9

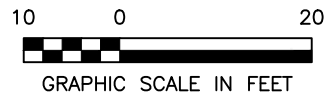
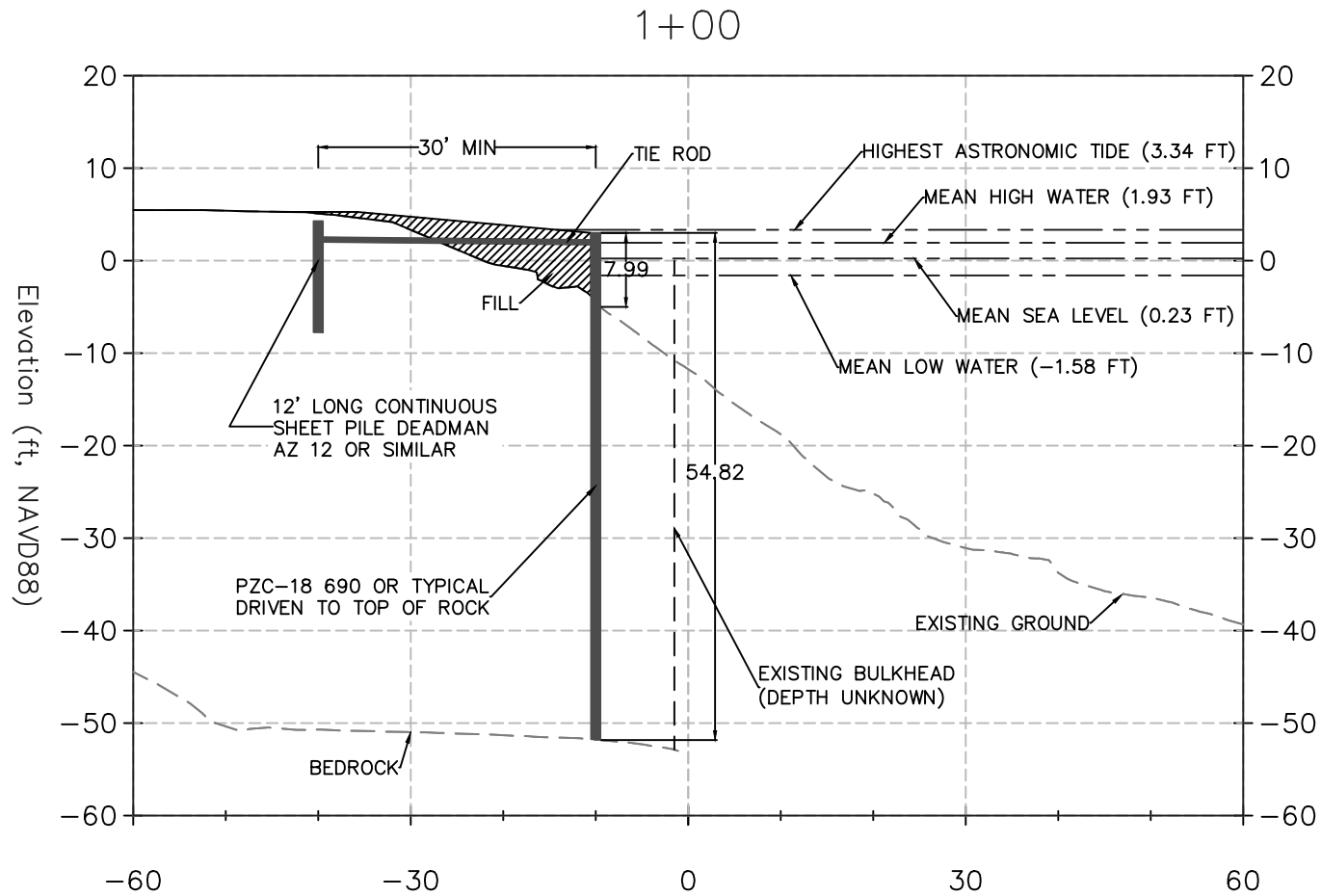

CENTRAL HUDSON GAS & ELECTRIC
DUTCHESS COUNTY, NY

NAN-2017-00912-WNE

DATE: 09/20/17

PROPOSED STEEL BULKHEAD
CROSS SECTION OF STATION 1+00

FIGURE 4 OF 9

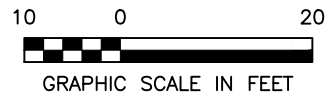
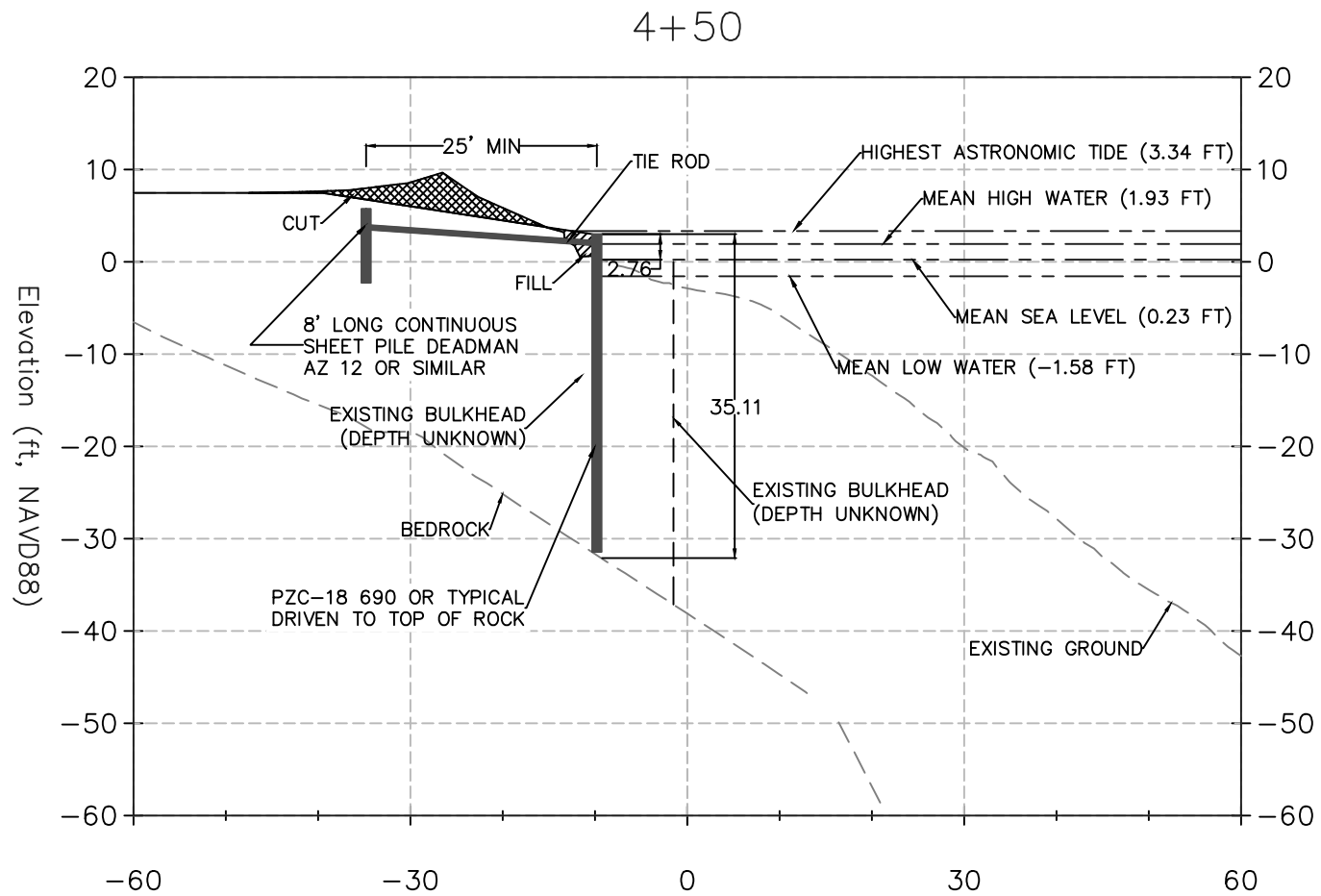

CENTRAL HUDSON GAS & ELECTRIC
DUTCHESS COUNTY, NY

NAN-2017-00912-WNE

DATE: 09/20/17

PROPOSED STEEL BULKHEAD
CROSS SECTION OF STATION 4+50

FIGURE 5 OF 9

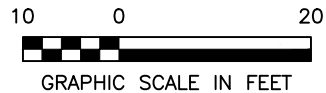
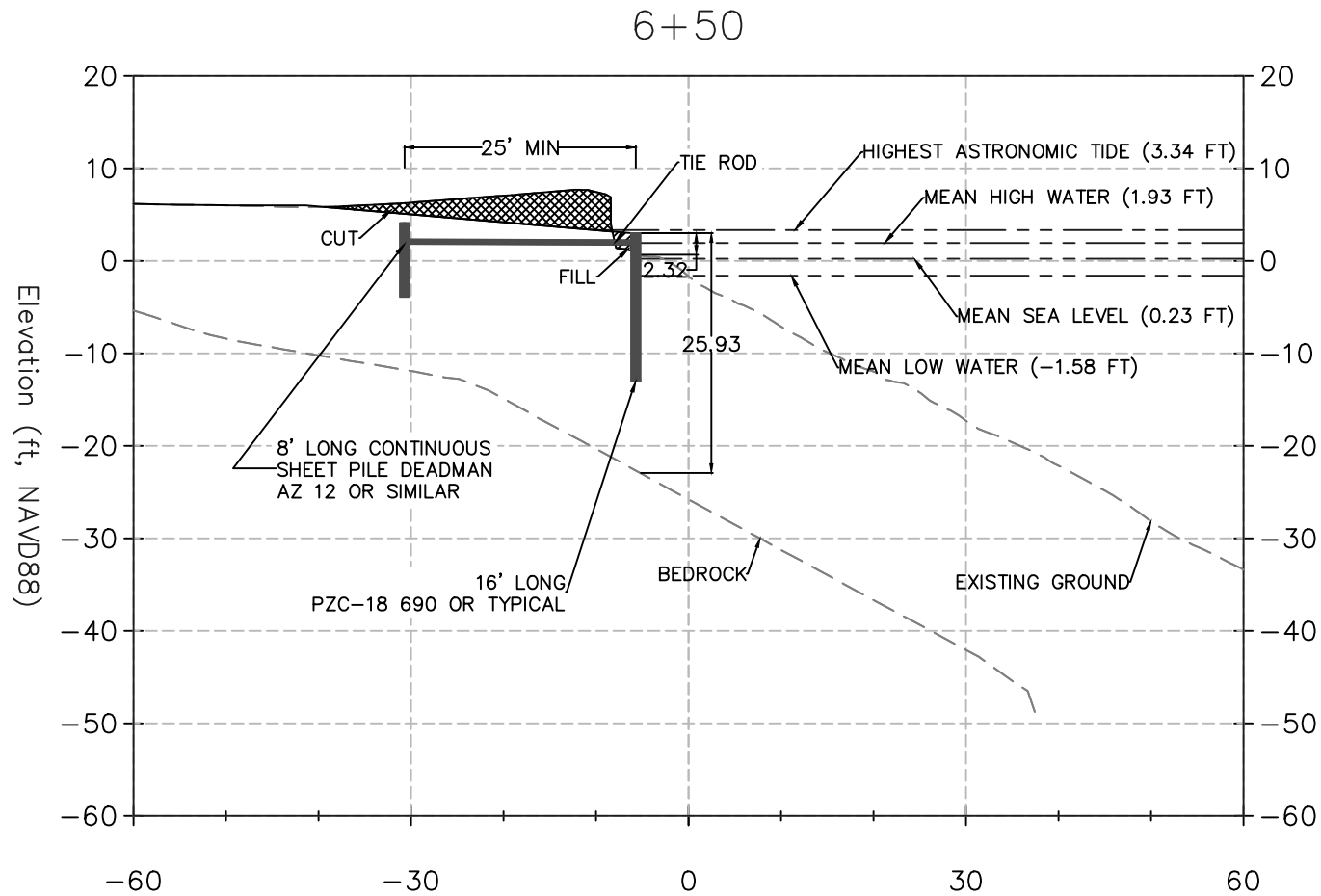

CENTRAL HUDSON GAS & ELECTRIC DUTCHESS COUNTY, NY NAN-2017-00912-WNE		PROPOSED STEEL BULKHEAD CROSS SECTION OF STATION 6+50
DATE: 09/20/17		FIGURE 6 OF 9

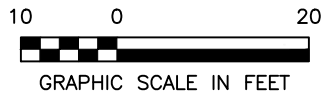
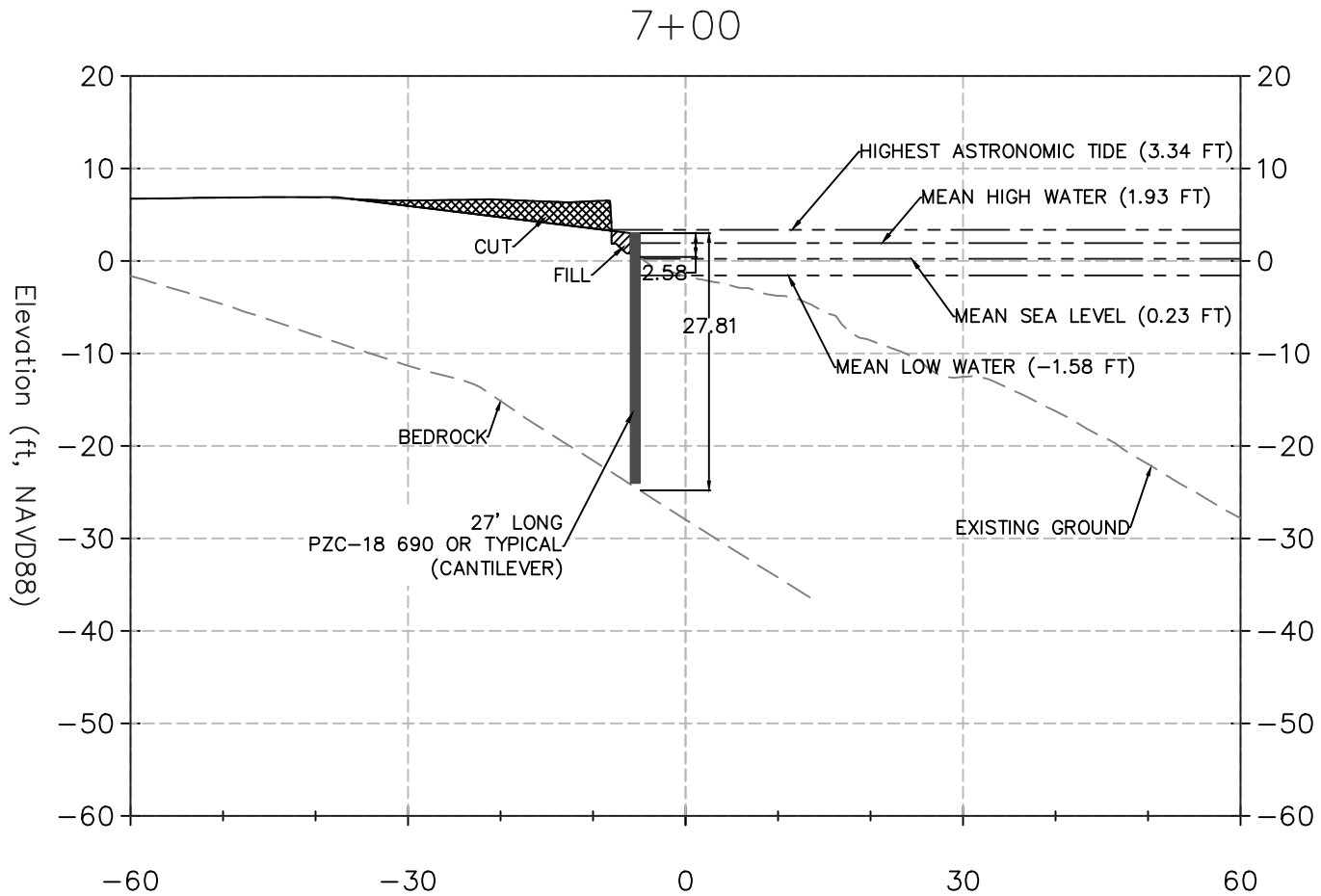

CENTRAL HUDSON GAS & ELECTRIC
DUTCHESS COUNTY, NY

NAN-2017-00912-WNE

DATE: 09/20/17

PROPOSED STEEL BULKHEAD
CROSS SECTION OF STATION 7+00

FIGURE 7 OF 9

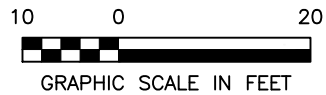
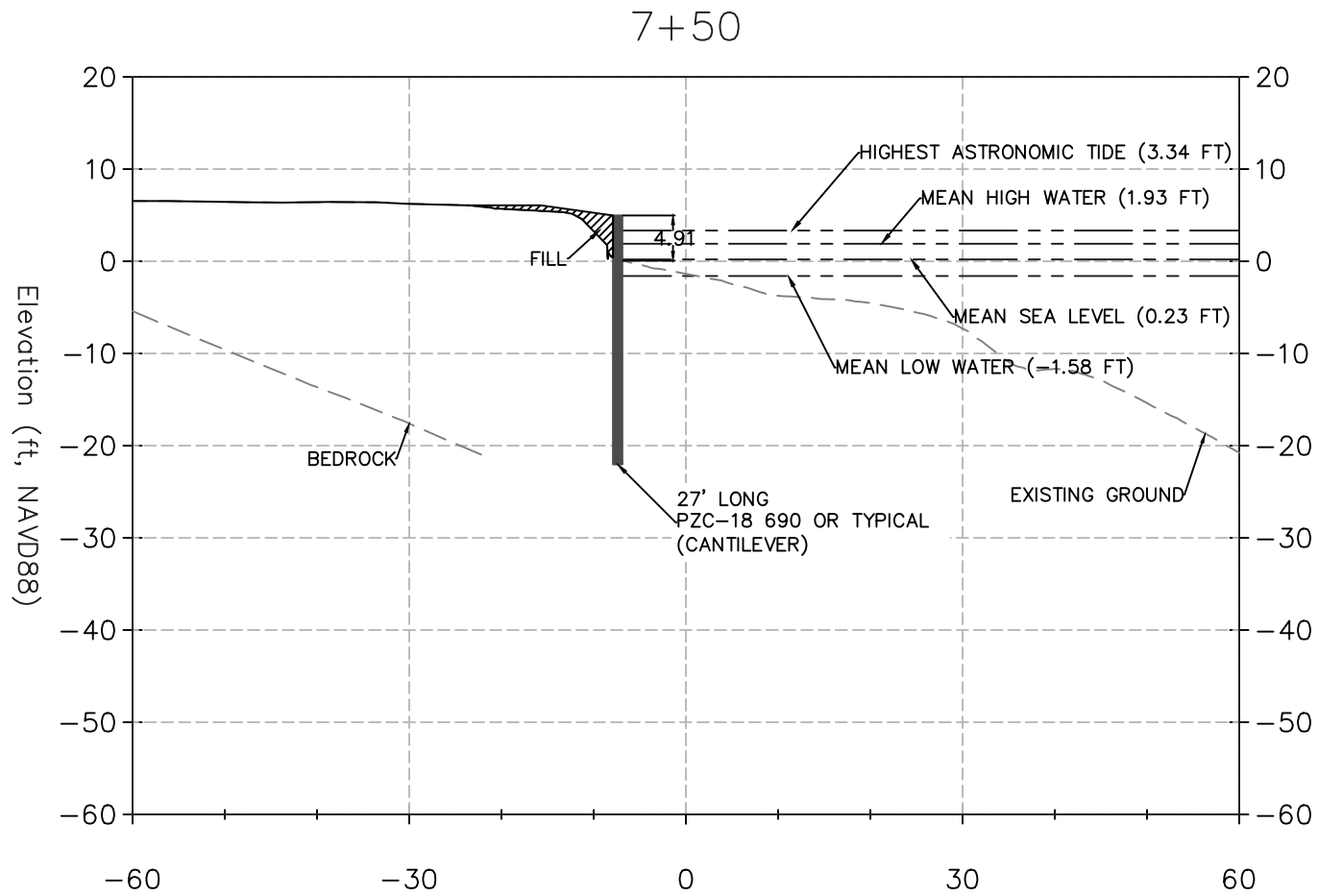

CENTRAL HUDSON GAS & ELECTRIC
DUTCHESS COUNTY, NY

NAN-2017-00912-WNE

DATE: 09/20/17

PROPOSED STEEL BULKHEAD
CROSS SECTION OF STATION 7+50

FIGURE 8 OF 9

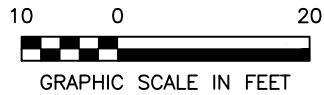
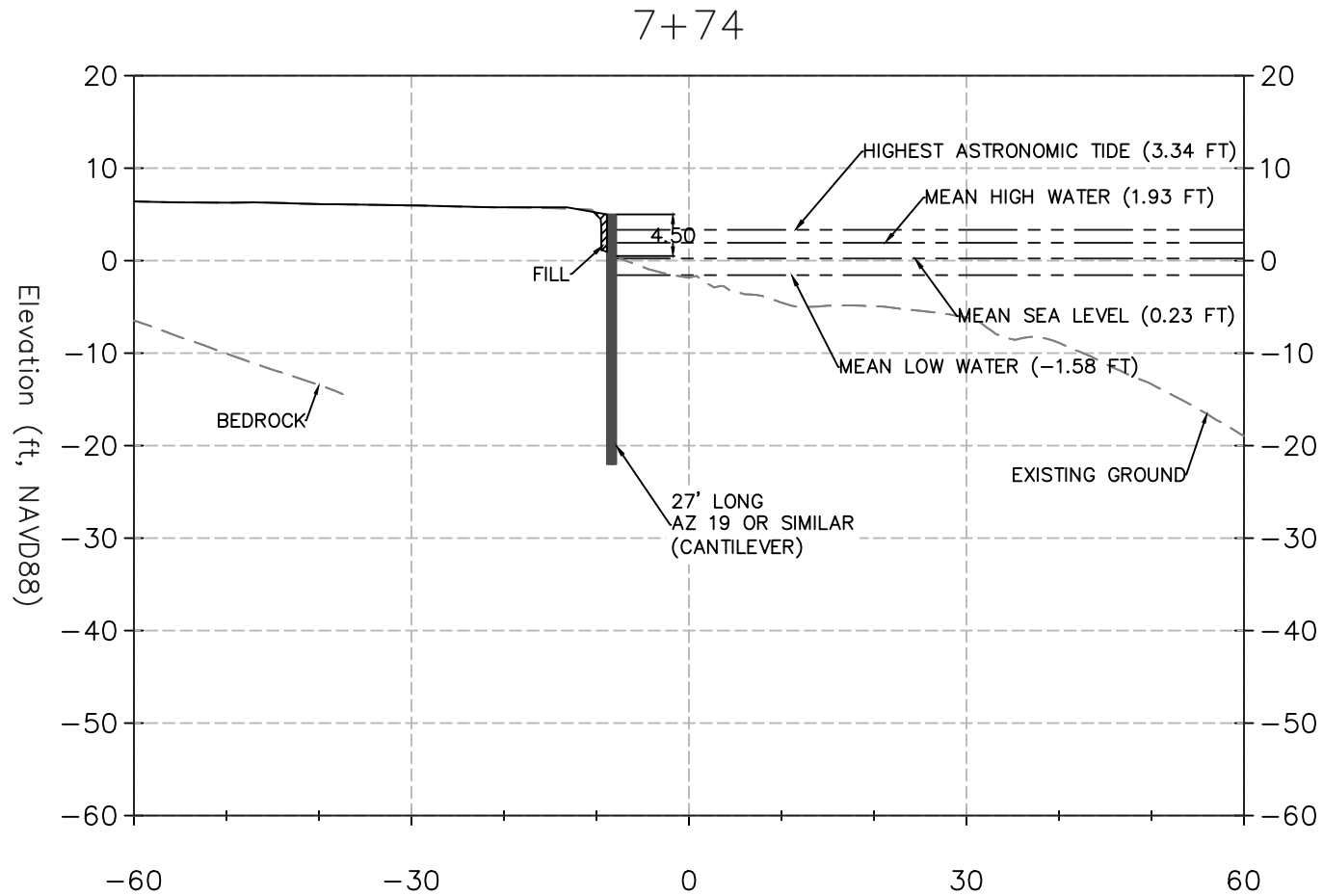

CENTRAL HUDSON GAS & ELECTRIC DUTCHESS COUNTY, NY NAN-2017-00912-WNE	PROPOSED STEEL BULKHEAD CROSS SECTION OF STATION 7+74
DATE: 09/20/17	FIGURE 9 OF 9

**Central Hudson Gas & Electric
 North Water Street MGP
 Material Use Calculations
 9/25/2017**

Tide at 2.32' NAVD88

Station	Width (ft)	Ave. Width (ft)	Length (ft)	Area (ft ²)
0+50	0.0			
		9.0	25.0	224.8
0+75	18.0			
		17.8	25.0	445.2
1+00	17.6			
		17.1	50.0	856.7
1+50	16.6			
		12.1	50.0	604.3
2+00	7.5			
		6.5	50.0	323.1
2+50	5.4			
		5.1	50.0	256.0
3+00	4.9			
		4.0	50.0	198.1
3+50	3.1			
		3.3	50.0	163.4
4+00	3.5			
		3.3	50.0	166.8
4+50	3.2			
		3.7	50.0	187.2
5+00	4.3			
		5.8	50.0	290.4
5+50	7.3			
		5.7	50.0	285.6
6+00	4.1			
		3.2	50.0	160.2
6+50	2.3			
		2.4	50.0	121.8
7+00	2.6			
		2.1	50.0	105.6
7+50	1.7			
		1.4	24.0	33.5
7+74	1.1			

Total Area= 4,422.7 ft²

0.1 acre

**Central Hudson Gas & Electric
 North Water Street MGP
 Material Use Calculations
 9/25/2017**

Tide at 3.34' NAVD88

Station	Width (ft)	Ave. Width (ft)	Length (ft)	Area (ft ²)
0+50	0.0			
		10.4	25.0	261.2
0+75	20.9			
		20.5	25.0	511.5
1+00	20.0			
		20.1	50.0	1003.9
1+50	20.1			
		16.4	50.0	821.4
2+00	12.7			
		9.2	50.0	461.2
2+50	5.7			
		5.3	50.0	266.4
3+00	4.9			
		4.1	50.0	204.6
3+50	3.3			
		3.4	50.0	169.1
4+00	3.5			
		3.8	50.0	190.2
4+50	4.1			
		5.5	50.0	272.5
5+00	6.8			
		8.2	50.0	409.2
5+50	9.6			
		7.8	50.0	391.4
6+00	6.1			
		4.3	50.0	215.0
6+50	2.5			
		2.5	50.0	126.5
7+00	2.6			
		2.6	50.0	130.4
7+50	2.7			
		1.9	24.0	45.5
7+74	1.1			

Total Area= 5,479.9 ft²

0.1 acre

Central Hudson Gas & Electric
North Water Street MGP
Material Use Calculations
9/25/2017

Station	Area (ft ²)	Ave. Area (ft ²)	Length (ft)	Volume (ft ³)
0+50	0.0			
		39.0	25.0	975.6
0+75	78.0			
		83.9	25.0	2098.6
1+00	89.8			
		83.6	50.0	4181.0
1+50	77.4			
		52.9	50.0	2646.9
2+00	28.5			
		21.5	50.0	1075.4
2+50	14.5			
		16.7	50.0	834.0
3+00	18.8			
		12.9	50.0	643.9
3+50	6.9			
		8.2	50.0	408.2
4+00	9.4			
		7.8	50.0	391.3
4+50	6.3			
		7.7	50.0	383.3
5+00	9.1			
		25.6	50.0	1281.9
5+50	42.2			
		61.0	50.0	3050.2
6+00	79.8			
		41.5	50.0	2075.6
6+50	3.2			
		3.4	50.0	172.2
7+00	3.7			
		8.7	50.0	434.5
7+50	13.7			
		8.2	24.0	197.8
7+74	2.8			

Total Volume= 20,850.7 ft³

Attachment 3

A Completed Essential Fish Habitat (EFH) Worksheet and
Correspondence with NOAA/National Marine Fisheries Service,
Mid-Atlantic Office

From: [Mansky, James](#)
To: [Forstner, Robert](#)
Cc: [Pandya, Shail](#)
Subject: FW: Proposed dredging in the Hudson River
Date: Friday, October 14, 2016 11:57:09 AM

Rob:

See the response from Karen Greene regarding the restriction on dredging in the Hudson River.

Jim

From: Karen Greene - NOAA Federal [mailto:karen.greene@noaa.gov]
Sent: Friday, October 14, 2016 11:53 AM
To: Mansky, James
Cc: edith.carson@noaa.gov
Subject: Re: Proposed dredging in the Hudson River

Hi Jim,

For HCD, we would likely recommend dredging be avoided from March 1 to June 30 for migrating and spawning anadromous fish. Poughkeepsie is at the edge of EFH,. The site may be north of the mixing zone line. So an assessment would not be needed and we would not have any other time of year restrictions.

Karen

Karen Greene
Mid-Atlantic Field Offices Supervisor
NOAA/National Marine Fisheries Service
Greater Atlantic Regional Fisheries Office
Habitat Conservation Division
James J. Howard Marine Sciences Laboratory
74 Magruder Rd.
Highlands, NJ 07732
732 872-3023 (office)

On Fri, Oct 14, 2016 at 11:44 AM, Mansky, James <James.Mansky@aecom.com> wrote:

AECOM is evaluating a proposed dredging project in the Hudson River at the location shown on the attached map. Disposal of the dredged material would be at an approved upland site.

So that the dredging program can be designed, it is requested that you identify the time restrictions when dredging would not be authorized in the Hudson River.

Let me know if you have any questions.

Thanks, Jim

James Mansky
Senior Project Director
Environment
D [212.377.8736](tel:212.377.8736)
james.mansky@aecom.com<<mailto:james.mansky@aecom.com>>

AECOM
125 Broad Street
New York, NY 10004
T [212.377.8400](tel:212.377.8400) F [212.377.8410](tel:212.377.8410)

NOAA FISHERIES
GREATER ATLANTIC REGIONAL FISHERIES OFFICE
Essential Fish Habitat (EFH) Consultation Guidance
EFH ASSESSMENT WORKSHEET

Introduction:

The Magnuson-Stevens Fishery Conservation and Management Act (MSA) mandates that federal agencies conduct an essential fish habitat (EFH) consultation with NOAA Fisheries regarding any of their actions authorized, funded, or undertaken that may adversely affect EFH. An adverse effect means any impact that reduces the quality and/or quantity of EFH. Adverse effects may include direct or indirect physical, chemical, or biological alterations of the waters or substrate and loss of, or injury to, benthic organisms, prey species and their habitat, and other ecosystem components. Adverse effects to EFH may result from actions occurring within EFH or outside of EFH and may include site-specific or habitat-wide impacts, including individual, cumulative, or synergistic consequences of actions.

This worksheet has been designed to assist in determining whether a consultation is necessary and in preparing EFH assessments. This worksheet should be used as your EFH assessment or as a guideline for the development of your EFH assessment. At a minimum, all the information required to complete this worksheet should be included in your EFH assessment. If the answers in the worksheet do not fully evaluate the adverse effects to EFH, we may request additional information in order to complete the consultation.

An expanded EFH assessment may be required for more complex projects in order to fully characterize the effects of the project and the avoidance and minimization of impacts to EFH. While the EFH worksheet may be used for larger projects, the format may not be sufficient to incorporate the extent of detail required, and a separate EFH assessment may be developed. However, regardless of format, the analysis outlined in this worksheet should be included for an expanded EFH assessment, along with additional information that may be necessary. This additional information includes:

- the results of on-site inspections to evaluate the habitat and site-specific effects
- the views of recognized experts on the habitat or the species that may be affected
- a review of pertinent literature and related information
- an analysis of alternatives to the action that could avoid or minimize the adverse effects on EFH.

Your analysis of adverse effects to EFH under the MSA should focus on impacts to the habitat for all life stages of species with designated EFH, rather than individual responses of fish species. Fish habitat includes the substrate and benthic resources (e.g., submerged aquatic vegetation, shellfish beds, salt marsh wetlands), as well as the water column and prey species.

Consultation with us may also be necessary if a proposed action results in adverse impacts to other NOAA-trust resources. Part 6 of the worksheet is designed to help assess the effects of the action on other NOAA-trust resources. This helps maintain efficiency in our interagency coordination process. In addition, further consultation may be required if a proposed action impacts marine mammals or threatened and endangered species for which we are responsible. Staff from our Greater Atlantic Regional Fisheries Office, Protected Resources Division should be contacted regarding potential impacts to marine mammals or threatened and endangered species.

Instructions for Use:

Federal agencies must submit an EFH assessment to NOAA Fisheries as part of the EFH consultation. Your EFH assessment must include:

- 1) A description of the proposed action.
- 2) An analysis of the potential adverse effects of the action on EFH, and the managed species.
- 3) The federal agency's conclusions regarding the effects of the action on EFH.
- 4) Proposed mitigation if applicable.

In order for this worksheet to be considered as your EFH assessment, you must answer the questions in this worksheet fully and with as much detail as available. Give brief explanations for each answer.

Federal action agencies or the non-federal designated lead agency should submit the completed worksheet to NOAA Fisheries Greater Atlantic Regional Fisheries Office, Habitat Conservation Division (HCD) with the public notice or project application. Include project plans showing existing and proposed conditions, all waters of the U.S. on the project site, with mean low water (MLW), mean high water (MHW), high tide line (HTL), and water depths clearly marked and sensitive habitats mapped, including special aquatic sites (submerged aquatic vegetation, saltmarsh, mudflats, riffles and pools, coral reefs, and sanctuaries and refuges), hard bottom habitat areas and shellfish beds, as well as any available site photographs.

For most consultations, NOAA Fisheries has 30 days to provide EFH conservation recommendations once we receive a complete EFH assessment. Submitting all necessary information at once minimizes delays in review and keeps review timelines consistent. Delays in providing a complete EFH assessment can result in our consultation review period extending beyond the public comment period for a particular project.

The information contained on the [HCD website](#) will assist you in completing this worksheet. The HCD website contains information regarding: the EFH consultation process; Guide to EFH Designations which provides a geographic species list; Guide to EFH Species Descriptions which provides the legal description of EFH as well as important ecological information for each species and life stage; and other EFH reference documents including examples of EFH assessments and EFH consultations.

Our website also includes a link to the [NOAA EFH Mapper](#) .

We would note that the EFH Mapper is currently being updated and revised. Should you use the EFH Mapper to identify federally managed species with designated EFH in your project area, we recommend checking this list against the [Guide to Essential Fish Habitat Designations in the Northeast](#) to ensure a complete and accurate list is provided.

EFH ASSESSMENT WORKSHEET FOR FEDERAL AGENCIES (modified 3/2016)

PROJECT NAME:

DATE:

PROJECT NO.:

LOCATION (Water body, county, physical address):

PREPARER:

Step 1: Use the Habitat Conservation Division EFH webpage's [Guide to Essential Fish Habitat Designations](#) in the Northeastern United States to generate the list of designated EFH for federally-managed species for the geographic area of interest. Use the species list as part of the initial screening process to determine if EFH for those species occurs in the vicinity of the proposed action. The list can be included as an attachment to the worksheet. Make a preliminary determination on the need to conduct an EFH consultation.

1. INITIAL CONSIDERATIONS		
EFH Designations	Yes	No
Is the action located in or adjacent to EFH designated for eggs? List the species:		
Is the action located in or adjacent to EFH designated for larvae? List the species:		
Is the action located in or adjacent to EFH designated for juveniles? List the species:		

<p>Is the action located in or adjacent to EFH designated for adults or spawning adults? List the species:</p>		
<p>If you answered 'no' to all questions above, then an EFH consultation is not required - go to Section 5. If you answered 'yes' to any of the above questions, proceed to Section 2 and complete the remainder of the worksheet.</p>		

Step 2: In order to assess impacts, it is critical to know the habitat characteristics of the site before the activity is undertaken. Use existing information, to the extent possible, in answering these questions. Identify the sources of the information provided and provide as much description as available. These should not be yes or no answers. Please note that there may be circumstances in which new information must be collected to appropriately characterize the site and assess impacts. Project plans that show the location and extent of sensitive habitats, as well as water depths, the HTL, MHW and MLW should be provided.

2. SITE CHARACTERISTICS	
Site Characteristics	Description
Is the site intertidal, sub-tidal, or water column?	
What are the sediment characteristics?	
Is there submerged aquatic vegetation (SAV) at or adjacent to project site? If so describe the SAV species and spatial extent.	
Are there wetlands present on or adjacent to the site? If so, describe the spatial extent and vegetation types.	

<p>Is there shellfish present at or adjacent to the project site? If so, please describe the spatial extent and species present.</p>	
<p>Are there mudflats present at or adjacent to the project site? If so please describe the spatial extent.</p>	
<p>Is there rocky or cobble bottom habitat present at or adjacent to the project site? If so, please describe the spatial extent.</p>	
<p>Is Habitat Area of Particular Concern (HAPC) designated at or near the site? If so for which species, what type habitat type, size, characteristics?</p>	
<p>What is the typical salinity, depth and water temperature regime/range?</p>	
<p>What is the normal frequency of site disturbance, both natural and man-made?</p>	
<p>What is the area of proposed impact (work footprint & far afield)?</p>	

Step 3: This section is used to describe the anticipated impacts from the proposed action on the physical/chemical/biological environment at the project site and areas adjacent to the site that may be affected.

3. DESCRIPTION OF IMPACTS			
Impacts	Y	N	Description
Nature and duration of activity(s). Clearly describe the activities proposed and the duration of any disturbances.			
Will the benthic community be disturbed? If no, why not? If yes, describe in detail how the benthos will be impacted.			
Will SAV be impacted? If no, why not? If yes, describe in detail how the SAV will be impacted. Consider both direct and indirect impacts. Provide details of any SAV survey conducted at the site.			
Will salt marsh habitat be impacted? If no, why not? If yes, describe in detail how wetlands will be impacted. What is the aerial extent of the impacts? Are the effects temporary or permanent?			

<p>Will mudflat habitat be impacted? If no, why not? If yes, describe in detail how mudflats will be impacted. What is the aerial extent of the impacts? Are the effects temporary or permanent?</p>			
<p>Will shellfish habitat be impacted? If so, provide in detail how the shellfish habitat will be impacted. What is the aerial extent of the impact? Provide details of any shellfish survey conducted at the site.</p>			
<p>Will hard bottom (rocky, cobble, gravel) habitat be impacted at the site? If so, provide in detail how the hard bottom will be impacted. What is the aerial extent of the impact?</p>			
<p>Will sediments be altered and/or sedimentation rates change? If no, why not? If yes, describe how.</p>			
<p>Will turbidity increase? If no, why not? If yes, describe the causes, the extent of the effects, and the duration.</p>			

<p>Will water depth change? What are the current and proposed depths?</p>			
<p>Will contaminants be released into sediments or water column? If yes, describe the nature of the contaminants and the extent of the effects.</p>			
<p>Will tidal flow, currents, or wave patterns be altered? If no, why not? If yes, describe in detail how.</p>			
<p>Will water quality be altered? If no, why not? If yes, describe in detail how. If the effects are temporary, describe the duration of the impact.</p>			
<p>Will ambient noise levels change? If no, why not? If yes, describe in detail how. If the effects are temporary, describe the duration and degree of impact.</p>			
<p>Does the action have the potential to impact prey species of federally managed fish with EFH designations?</p>			

Step 4: This section is used to evaluate the consequences of the proposed action on the functions and values of EFH as well as the vulnerability of the EFH species and their life stages. Identify which species (from the list generated in Step 1) will be adversely impacted from the action. Assessment of EFH impacts should be based upon the site characteristics identified in Step 2 and the nature of the impacts described within Step 3. The [Guide to EFH Descriptions webpage](#) should be used during this assessment to determine the ecological parameters/preferences associated with each species listed and the potential impact to those parameters.

4. EFH ASSESSMENT			
Functions and Values	Y	N	Describe habitat type, species and life stages to be adversely impacted
Will functions and values of EFH be impacted for:			
Spawning If yes, describe in detail how, and for which species. Describe how adverse effects will be avoided and minimized.			
Nursery If yes, describe in detail how and for which species. Describe how adverse effects will be avoided and minimized.			
Forage If yes, describe in detail how and for which species. Describe how adverse effects will be avoided and minimized.			
Shelter If yes, describe in detail how and for which species. Describe how adverse effects will be avoided and minimized.			

<p>Will impacts be temporary or permanent? Please indicate in description box and describe the duration of the impacts.</p>			
<p>Will compensatory mitigation be used? If no, why not? Describe plans for mitigation and how this will offset impacts to EFH. Include a conceptual compensatory mitigation plan, if applicable.</p>			

Step 5: This section provides the federal agency's determination on the degree of impact to EFH from the proposed action. The EFH determination also dictates the type of EFH consultation that will be required with NOAA Fisheries.

Please note: if information provided in the worksheet is insufficient to allow NOAA Fisheries to complete the EFH consultation additional information will be requested.

<p>5. DETERMINATION OF IMPACT</p>		
<p>Federal Agency's EFH Determination</p>		
<p>Overall degree of adverse effects on EFH (not including compensatory mitigation) will be: (check the appropriate statement)</p>		<p>There is no adverse effect on EFH or no EFH is designated at the project site. EFH Consultation is not required.</p>
		<p>The adverse effect on EFH is not substantial. This means that the adverse effects are either no more than minimal, temporary, or that they can be alleviated with minor project modifications or conservation recommendations. This is a request for an abbreviated EFH consultation.</p>
		<p>The adverse effect on EFH is substantial. This is a request for an expanded EFH consultation.</p>

Step 6: Consultation with NOAA Fisheries may also be required if the proposed action results in adverse impacts to other NOAA-trust resources, such as anadromous fish, shellfish, crustaceans, or their habitats as part of the Fish and Wildlife Coordination Act. Some examples of other NOAA-trust resources are listed below. Inquiries regarding potential impacts to marine mammals or threatened/endangered species should be directed to NOAA Fisheries' Protected Resources Division.

6. OTHER NOAA-TRUST RESOURCES IMPACT ASSESSMENT	
Species known to occur at site (list others that may apply)	Describe habitat impact type (i.e., physical, chemical, or biological disruption of spawning and/or egg development habitat, juvenile nursery and/or adult feeding or migration habitat). Please note, impacts to federally listed species of fish, sea turtles, and marine mammals must be coordinated with the GARFO Protected Resources Division.
alewife	
American eel	
American shad	
Atlantic menhaden	
blue crab	
blue mussel	
blueback herring	

Eastern oyster	
horseshoe crab	
quahog	
soft-shell clams	
striped bass	
other species:	

Useful Links

[National Wetland Inventory Maps](#)

[EPA's National Estuaries Program](#)

[Northeast Regional Ocean Council \(NROC\) Data](#)

[Mid-Atlantic Regional Council on the Ocean \(MARCO\) Data](#)

Resources by State:

Maine

[Eelgrass maps](#)

[Maine Office of GIS Data Catalog](#)

[Casco Bay Estuary Partnership](#)

[Maine GIS Stream Habitat Viewer](#)

New Hampshire

[New Hampshire's Statewide GIS Clearinghouse, NH GRANIT](#)

[New Hampshire Coastal Viewer](#)

Massachusetts

[Eelgrass maps](#)

[MADMF Recommended Time of Year Restrictions Document](#)

[Massachusetts Bays National Estuary Program](#)

[Buzzards Bay National Estuary Program](#)

[Massachusetts Division of Marine Fisheries](#)

[Massachusetts Office of Coastal Zone Management](#)

Rhode Island

[Eelgrass maps](#)

[Narraganset Bay Estuary Program](#)

[Rhode Island Division of Marine Fisheries](#)

[Rhode Island Coastal Resources Management Council](#)

Connecticut

[Eelgrass Maps](#)

[Long Island Sound Study](#)

[CT GIS Resources](#)

[CT DEEP Office of Long Island Sound Programs and Fisheries](#)

[CT Bureau of Aquaculture Shellfish](#)

[Maps CT River Watershed Council](#)

New York

[Eelgrass report](#)

[Peconic Estuary Program](#)

[NY/NJ Harbor Estuary](#)

New Jersey

[Submerged Aquatic Vegetation mapping](#)

[Barnegat Bay Partnership](#)

Delaware

[Partnership for the Delaware Estuary](#)

[Center for Delaware Inland Bays](#)

Maryland

[Submerged Aquatic Vegetation mapping](#)

[MERLIN](#)

[Maryland Coastal Bays Program](#)

Virginia

[Submerged Aquatic Vegetation mapping](#)

Attachment 4

2017 NLAA Program Verification Form

GARFO ESA Section 7: 2017 NLAA Program Verification Form

(Please submit a signed version of this form, together with any project plans, maps, supporting analyses, etc., to nmfs.gar.esa.section7@noaa.gov with "2017 NLAA Program" in the subject line)

Section 1: General Project Details

Application Number:			
Applicant(s):			
Permit Type (e.g. NWP, LOP, RGP, IP, Permit Modification):			
Anticipated project start date (e.g., 9/1/2017)			
Anticipated project end date (e.g., 3/14/2018 – if there is no permit expiration date, write “N/A”)			
Project Type/Category (check all that apply to entire action):			
<input type="checkbox"/>	Aquaculture (shellfish) and artificial reef creation	<input type="checkbox"/>	Transportation and development (e.g., culvert construction, bridge repair)
<input type="checkbox"/>	Routine maintenance dredging and disposal/beach nourishment	<input type="checkbox"/>	Mitigation (fish/wildlife enhancement or restoration)
<input type="checkbox"/>	Piers, ramps, floats, and other structures	<input type="checkbox"/>	Bank stabilization and dam maintenance
<input type="checkbox"/>	If other, describe project type/category:		
Project/Action Description and Purpose (<i>include town/city/state and water body where project is occurring; relevant permit conditions that aren't captured elsewhere on form</i>):			

Type of Habitat Modified (e.g., sand, cobble, silt/mud/clay):	Area (acres):
Project Latitude (e.g., 42.625884)	
Project Longitude (e.g., -70.646114)	

Section 2: ESA-listed species and/or critical habitat in the action area:

Atlantic sturgeon (all DPSs) If not all DPSs, list which here: 	Kemp’s ridley sea turtle
Atlantic sturgeon critical habitat (proposed or designated) Indicate which DPS (GOM, NYB, Chesapeake Bay DPSs): 	Loggerhead sea turtle (NW Atlantic DPS)
Shortnose sturgeon	Leatherback sea turtle
Atlantic salmon (GOM DPS)	North Atlantic right whale
Atlantic salmon critical habitat (GOM DPS)	North Atlantic right whale critical habitat
Green sea turtle (N. Atlantic DPS)	Fin whale

Section 3: NLAA Determination (check all applicable fields):

a) GENERAL PDC	
	Yes, my project meets all of the General PDC.
	No, my project does not meet all the General PDC as indicated below (please check the PDC the action does NOT comply with below, and provide justification in Section 4 of this form):
	Information for PDC 8 (if “max extent of stressor” exceeds “width of water body”, PDC 8 is NOT met, and a justification in Section 4 is required to proceed with the verification form)

	Width (m) of water body in action area:	Stressor Category (stressor that extends furthest distance into water body – e.g., turbidity plume; sound pressure wave):	Max extent (m) of stressor into the water body:
1.	No work will individually or cumulatively have an adverse effect on ESA-listed species or designated critical habitat; no work will cause adverse modification or destruction to proposed critical habitat.		
2.	No work will occur in the tidally influenced portion of rivers/streams where Atlantic salmon presence is possible from April 10–November 7.		
3.	No work will occur in Atlantic or shortnose sturgeon spawning grounds as follows: i. New England: April 1–Aug. 31 ii. New York/Philadelphia: March 15–August 31 iii. Baltimore/Norfolk: March 15–July 1 and Sept. 15–Nov. 1		
4.	No work will occur in shortnose sturgeon overwintering grounds as follows: i. New England District: October 15–April 30 ii. New York/Philadelphia: Nov. 1–March 15 iii. Baltimore: Nov. 1–March 15		
5.	Within designated Atlantic salmon critical habitat, no work will affect spawning and rearing areas (PBFs 1-7).		
6.	Within proposed/designated Atlantic sturgeon critical habitat, no work will affect hard bottom substrate (e.g., rock, cobble, gravel, limestone, boulder, etc.) in low salinity waters (i.e., 0.0-0.5 parts per thousand) (PBF 1).		
7.	Work will not change temperature, water flow, salinity, or dissolved oxygen levels.		
8.	If it is possible for ESA-listed species to pass through the action area, a zone of passage with appropriate habitat for ESA-listed species (e.g., depth, water velocity, etc.) must be maintained (i.e., physical or biological stressors such as turbidity and sound pressure must not create barrier to passage).		
9.	Any work in designated North Atlantic right whale critical habitat must have no effect on the physical and biological features (PBFs).		
10.	The project will not adversely impact any submerged aquatic vegetation (SAV).		
11.	No blasting will occur.		

b) The following stressors are applicable to the action (check all that apply – use Stressor Category Table for guidance):	
<input type="checkbox"/>	Sound Pressure
<input type="checkbox"/>	Impingement/Entrapment/Capture
<input type="checkbox"/>	Turbidity/Water Quality
<input type="checkbox"/>	Entanglement

	Habitat Modification
	Vessel Traffic

Activity Category	Stressor Category					
	Sound Pressure	Impingement/ Entrapment/ Capture	Turbidity/ Water Quality	Entanglement	Habitat Mod.	Vessel Traffic
Aquaculture (shellfish) and artificial reef creation	N	N	Y	Y	Y	Y
Routine maintenance dredging and disposal/beach nourishment	N	Y	Y	N	Y	Y
Piers, ramps, floats, and other structures	Y	N	Y	Y	Y	Y
Transportation and development (e.g., culvert construction, bridge repair)	Y	N	Y	N	Y	Y
Mitigation (fish/wildlife enhancement or restoration)	N	N	Y	N	Y	Y
Bank stabilization and dam maintenance	Y	N	Y	N	Y	Y

c) SOUND PRESSURE PDC					
Yes, my project meets all of the Sound Pressure PDC below.					
No, my project does not meet all the Sound Pressure PDC as indicated below (please check the PDC the action does NOT comply with below, and provide justification in Section 4 of this form):					
Information for PDC 14 (refer to SOPs for guidance):					
	Pile material (e.g., steel pipe, timber, concrete)	Pile diameter/width (inches)	Number of piles	Installation method (e.g., impact hammer, vibratory start and then impact hammer to depth)	
a)					
b)					

	c)				
	d)				
	12.	If the pile driving is occurring during a time of year when ESA-listed species may be present, and the anticipated noise is above the behavioral noise threshold of those species (please see SOPs), a 20 minute “soft start” is required to allow for animals to leave the project vicinity before sound pressure increases.			
	13.	Any new pile supported structure must involve the installation of ≤ 50 piles (below MHW).			
	14.	All underwater noise (pressure) is below (<) the physiological/injury noise threshold for ESA-listed species in the action area (if project involves steel piles, or non-steel piles > 24-inches in diameter/width, include noise estimate with this form).			
d) IMPINGEMENT/ENTRAINMENT/CAPTURE PDC					
	Yes, my project meets all of the Impingement/Entrainment/Capture PDC below.				
	No, my project does not meet all the Impingement/Entrainment/Capture PDC as indicated below (please check the PDC the action does NOT comply with below, and provide justification in Section 4 of this form):				
	Information for Dredging:				
	If dredging permit/authorization includes multiple years of maintenance, include estimated number of dredging/disposal events:				
	Information for PDC 18 (refer to SOPs for guidance):				
	Mesh screen size (mm) for temporary intake:				
	15.	Only mechanical, cutterhead, and low volume hopper (e.g., CURRITUCK) dredges may be used.			
	16.	No new dredging in proposed or designated Atlantic sturgeon or Atlantic salmon critical habitat (maintenance dredging still must meet all other PDCs). New dredging outside Atlantic sturgeon or salmon critical habitat is limited to one time dredge events (e.g., burying a utility line) and minor (≤ 2 acres) expansions of areas already subject to maintenance dredging (e.g., marina/harbor expansion).			
	17.	Work behind cofferdams, turbidity curtains, and other methods to block access of animals to dredge footprint is required when operationally feasible and ESA-listed species may be present.			
	18.	Temporary intakes related to construction must be equipped with appropriate sized mesh screening (as determined by GARFO section 7 biologist and/or according to Chapter 11 of the NOAA Fisheries Anadromous Salmonid Passage Facility Design) and must not have greater than 0.5 fps intake velocities, to prevent impingement or entrainment of any ESA-listed species life stage.			
	19.	No new permanent intake structures related to cooling water, or any other inflow at facilities (e.g. water treatment plants, power plants, etc.).			
e) TURBIDITY/WATER QUALITY PDC					
	Yes, my project meets all of the Turbidity/Water Quality PDC below.				

	No, my project does not meet all the Turbidity/Water Quality PDC as indicated below (please check the PDC the action does NOT comply with below, and provide justification in Section 4 of this form):
20.	Work behind cofferdams, turbidity curtains, or other methods to control turbidity are required when operationally feasible and ESA-listed species may be present.
21.	In-water offshore disposal may only occur at designated disposal sites that have already been consulted on with GARFO.
22.	Any temporary discharges must meet state water quality standards; no discharges of toxic substances.
23.	Only repair of existing discharge pipes allowed; no new construction.

f) ENTANGLEMENT PDC

Yes, my project meets all of the Entanglement PDC below.

No, my project does not meet all the Entanglement PDC as indicated below (please check the PDC the action does NOT comply with below, and provide justification in Section 4 of this form):

Information for Aquaculture Projects:		
	Type of Aquaculture (e.g., cage on bottom)	Acreage
a)		
b)		
c)		

24. Shell on bottom <50 acres with maximum of 4 corner marker buoys;

25. Cage on bottom with no loose floating lines <5 acres and minimal vertical lines (1 per string of cages, 4 corner marker buoys);

26. Floating cages in <3 acres in waters and shallower than -10 feet MLLW with no loose lines and minimal vertical lines (1 per string of cages, 4 corner marker buoys);

27. Floating upweller docks in >10 feet MLLW.

28. Any in-water lines, ropes, or chains must be made of materials and installed in a manner (properly spaced) to minimize the risk of entanglement by keeping lines taut or using methods to promote rigidity (e.g., sheathed or weighted lines that do not loop or entangle).

g) HABITAT MODIFICATION PDC

Yes, my project meets all of the Habitat Modification PDC below.

No, my project does not meet all the Habitat Modification PDC as indicated below (please check the PDC the action does NOT comply with below, and provide justification in Section 4 of this form):

	29.	No conversion of habitat type (soft bottom to hard, or vice versa) for aquaculture or reef creation.
h) VESSEL TRAFFIC PDC		
	Yes, my project meets all of the Vessel Traffic PDC below.	
	No, my project does not meet all the Vessel Traffic PDC as indicated below (please check the PDC the action does NOT comply with below, and provide justification in Section 4 of this form):	
	Information for PDC 33 (refer to SOPs for guidance):	
	Temporary Project Vessel Type (e.g., work barge, tug, scow, etc.)	Number of Vessels
	a)	
	b)	
	c)	
	Type of Non-Commercial Vessels Added (e.g., 20' recreational motor boat – only include if there is a net increase directly/indirectly resulting from project)	Number of Vessels (if sum > 2, PDC 33 is not met and justification required in Section 4)
	a)	
	b)	
	Type of Commercial Vessels Added (only include if there is a net increase directly/indirectly resulting from project)	Number of Vessels (if > 0, PDC 33 is not met and justification required in Section 4)
	a)	
	b)	
	30.	Speed limits below 10 knots for project vessels with buffers of 150 feet for all listed species (1,500 feet for right whales).
	31.	While dredging, dredge buffers of 300 feet in the vicinity of any listed species (1,500 feet for right whales), with speeds of 4 knots maximum.
	32.	The number of project vessels must be limited to the greatest extent possible, as appropriate to size and scale of project.
	33.	The permanent net increase in vessels resulting from a project (e.g., dock/float/pier/boating facility) must not exceed two non-commercial vessels. A project must not result in the permanent net increase of any commercial vessels (e.g., a ferry terminal).

Section 4: Justification for Review under the 2017 NLAA Program

If the action is not in compliance with all of the General PDC and appropriate stressor PDC, but you can provide justification and/or special conditions to demonstrate why the project still meets the NLAA determination and is consistent with the aggregate effects considered in the programmatic consultation, you may still certify your project through the NLAA program using

this verification form. Please identify which PDC your project does not meet (e.g., PDC 9, PDC 15, PDC 22, etc.) and provide your rationale and justification for why the project is still eligible for the verification form.

To demonstrate that the project is still NLAA, you must explain why the effects on ESA-listed species or critical habitat are **insignificant** (i.e., too small to be meaningfully measured or detected) or **discountable** (i.e., extremely unlikely to occur). Please use this language in your justification.

PDC#	Justification

Section 5: USACE Verification of Determination

	In accordance with the 2017 NLAA Programmatic Consultation, the Corps has determined that the action complies with all applicable PDC and is not likely to adversely affect listed species.
	In accordance with the 2017 NLAA Programmatic Consultation, the Corps has determined that the action is not likely to adversely affect listed species per the justification and/or special conditions provided in Section 4.
	USACE Signature:
	Date:

Section 6: GARFO Concurrence

	In accordance with the 2017 NLAA Program, GARFO PRD concurs with USACE’s determination that the action complies with all applicable PDC and is not likely to adversely affect listed species or critical habitat.
	In accordance with the 2017 NLAA Program, GARFO PRD concurs with USACE’s determination that the action is not likely to adversely affect listed species or critical habitat per the justification and/or special conditions provided in Section 4.
	GARFO PRD does not concur with USACE’s determination that the action complies with the applicable PDC (with or without justification), and recommends an individual Section 7 consultation to be completed independent from the 2017 NLAA Program.
	GARFO Signature:
	Date:

Attachment 5

Supporting Information Regarding Cultural Resources
from the New York State Historic Preservation Office



Parks, Recreation, and Historic Preservation

ANDREW M. CUOMO
Governor

ROSE HARVEY
Commissioner

September 26, 2017

Ms. Nancy Stehling
Senior Archaeologist
AECOM
125 Broad Street
16th Floor
New York, NY 10004

Re: USACE
Replacement of 900 Feet of Timber Bulkhead With New Steel Bulkhead, Former CHGE
MGP Site, North Water Street and Dutchess Avenue, Poughkeepsie, NY
17PR06345

Dear Ms. Stehling:

Thank you for requesting the comments of the State Historic Preservation Office (SHPO). We have reviewed the project in accordance with Section 106 of the National Historic Preservation Act of 1966. These comments are those of the SHPO and relate only to Historic/Cultural resources. They do not include potential environmental impacts to New York State Parkland that may be involved in or near your project. Such impacts must be considered as part of the environmental review of the project pursuant to the National Environmental Policy Act and/or the State Environmental Quality Review Act (New York Environmental Conservation Law Article 8).

Based upon this review, the New York SHPO has determined that no historic properties will be affected by this undertaking.

If further correspondence is required regarding this project, please be sure to refer to the OPRHP Project Review (PR) number noted above.

Sincerely,

Michael F. Lynch, P.E., AIA
Director, Division for Historic Preservation

Appendix J

United States Army Corps of Engineers Nationwide Permit No. 38 Joint Application - SUBMITTED JANUARY 2018

E-Format Only

Permit for Reference Only. Permit to be resubmitted in August 2018 that includes details from Nationwide Permit No. 3 (Previously Submitted in September 2017) and NYSDEC recommendations



AECOM
125 Broad Street, 16th floor
New York, NY 10004
www.aecom.com

212.377.8400 tel
212.377.8410 fax

January 12, 2018

U.S. Army Corps of Engineers, New York District
Attn: Regulatory Branch – Mr. Brendan Newell
26 Federal Plaza
New York, NY 10278-0090

RE: Permit Application Number NAN-2017-00912-WNE
Authorization for Coverage under Nationwide Permit 38
Former North Water Street MGP Site
Central Hudson Gas & Electric Corp.
2 Dutchess Avenue
Poughkeepsie, New York 12601

Dear Mr. Newell:

On behalf of Central Hudson Gas & Electric Corporation (CHGE), AECOM USA, Inc. (AECOM) submits the attached application and supporting materials for United States Army Corps of Engineers (USACE) review of the activities associated with the removal and capping of contaminated sediments from an approximately 7.6 acre portion of the Hudson River adjacent to the CHGE's North Water Street former Manufactured Gas Plant (MGP) site located in the city of Poughkeepsie, Dutchess County, New York and approval for the work to proceed under Nationwide Permit 38 (NWP38).

The work is being performed by CHGE in accordance with the Brownfield Cleanup Agreement (BCA) Index Number D3-0004-99-04 between the New York State Department of Environmental Conservation (NYSDEC) and CHGE and as required by the Decision Document prepared by the NYSDEC in March 2016.

The permit application package contains the following attachments:

1. Joint Application for Permit Form and Supplemental Project Information
2. Location Map and Site Plans
3. NYSDEC Decision Document
4. Site Photographs
5. Federal Consistency Assessment Form, Coastal Zone Consistency Policy Determination, and HIT Analysis
6. New York State Historic Preservation Office (SHPO) Review
7. Letter of No Objection from New York State Office of General Services (NYSOGS)
8. New York Natural Heritage Program Review
9. National Marine Fisheries Services Review
10. U.S. Fish and Wildlife Services Review
11. Abbreviated Essential Fish Habitat Assessment
12. Biological Assessment

Please let me know if you have any questions regarding this application or the attachments or require any additional information. Please do not hesitate to contact me at (212) 377-8708 or shail.pandya@aecom.com. We appreciate your timely review of this application package.

Sincerely,



Shail Pandya
Sr. Project Manager
AECOM

cc: Doug MacNeal – NYSDEC
Gardiner Cross – NYSDEC
Heather Gierloff – NYSDEC
Tracey O'Malley – NYSDEC
Mary Jo Crance – NYSDEC
Mark McLean – CHGE
Wayne Mancroni – CHGE
Jesse Gallo – CHGE
Michael Spera, PE – AECOM

Attachment 1

**Joint Permit Application Form and
Supplemental Project Information**



JOINT APPLICATION FORM

For Permits for activities affecting streams, waterways, waterbodies, wetlands, coastal areas, sources of water, and endangered and threatened species.

You must separately apply for and obtain Permits from each involved agency before starting work. Please read all instructions.

1. Applications To:
>NYS Department of Environmental Conservation
Check all permits that apply: Stream Disturbance, Dams and Impoundment Structures, Tidal Wetlands, Water Withdrawal, etc.
>US Army Corps of Engineers
Check all permits that apply: Section 404 Clean Water Act, Section 10 Rivers and Harbors Act
>NYS Office of General Services
Check all permits that apply: State Owned Lands Under Water, Utility Easement, Docks, Moorings or Platforms
>NYS Department of State
Check if this applies: Coastal Consistency Concurrence

2. Name of Applicant
Taxpayer ID (if applicant is NOT an individual)
Mailing Address
Post Office / City, State, Zip
Telephone, Email
Applicant Must be (check all that apply): Owner, Operator, Lessee

3. Name of Property Owner (if different than Applicant)
Mailing Address
Post Office / City, State, Zip
Telephone, Email

For Agency Use Only Agency Application Number:

4. Name of Contact / Agent

Mailing Address Post Office / City State Zip

Telephone Email

5. Project / Facility Name Property Tax Map Section / Block / Lot Number:

Project Street Address, if applicable Post Office / City State Zip

Provide directions and distances to roads, intersections, bridges and bodies of water

Town Village City County Stream/Waterbody Name

Project Location Coordinates: Enter Latitude and Longitude in degrees, minutes, seconds:
Latitude: ° ' " Longitude: ° ' "

6. Project Description: Provide the following information about your project. Continue each response and provide any additional information on other pages. **Attach plans on separate pages.**

a. Purpose of the proposed project:

b. Description of current site conditions:

c. Proposed site changes:

d. Type of structures and fill materials to be installed, and quantity of materials to be used (e.g., square feet of coverage, cubic yards of fill material, structures below ordinary/mean high water, etc.):

e. Area of excavation or dredging, volume of material to be removed, location of dredged material placement:

f. Is tree cutting or clearing proposed? Yes If Yes, explain below. No
Timing of the proposed cutting or clearing (month/year):
Number of trees to be cut: Acreage of trees to be cleared:

g. Work methods and type of equipment to be used:

h. Describe the planned sequence of activities:

i. Pollution control methods and other actions proposed to mitigate environmental impacts:

j. Erosion and silt control methods that will be used to prevent water quality impacts:

k. Alternatives considered to avoid regulated areas. If no feasible alternatives exist, explain how the project will minimize impacts:

l. Proposed use: Private Public Commercial

m. Proposed Start Date: Estimated Completion Date:

n. Has work begun on project? Yes If Yes, explain below. No

o. Will project occupy Federal, State, or Municipal Land? Yes If Yes, explain below. No

p. List any previous DEC, USACE, OGS or DOS Permit / Application numbers for activities at this location:

q. Will this project require additional Federal, State, or Local authorizations, including zoning changes?

Yes If Yes, list below. No

7. Signatures.

Applicant and Owner (If different) must sign the application.

Append additional pages of this Signature section if there are multiple Applicants, Owners or Contact/Agents.

I hereby affirm that information provided on this form and all attachments submitted herewith is true to the best of my knowledge and belief.

Permission to Inspect - I hereby consent to Agency inspection of the project site and adjacent property areas. Agency staff may enter the property without notice between 7:00 am and 7:00 pm, Monday - Friday. Inspection may occur without the owner, applicant or agent present. If the property is posted with "keep out" signs or fenced with an unlocked gate, Agency staff may still enter the property. Agency staff may take measurements, analyze site physical characteristics, take soil and vegetation samples, sketch and photograph the site. I understand that failure to give this consent may result in denial of the permit(s) sought by this application.

False statements made herein are punishable as a Class A misdemeanor pursuant to Section 210.45 of the NYS Penal Law. Further, the applicant accepts full responsibility for all damage, direct or indirect, of whatever nature, and by whomever suffered, arising out of the project described herein and agrees to indemnify and save harmless the State from suits, actions, damages and costs of every name and description resulting from said project. In addition, Federal Law, 18 U.S.C., Section 1001 provides for a fine of not more than \$10,000 or imprisonment for not more than 5 years, or both where an applicant knowingly and willingly falsifies, conceals, or covers up a material fact; or knowingly makes or uses a false, fictitious or fraudulent statement.

Signature of Applicant



Date

Applicant Must be (check all that apply): Owner Operator Lessee

Printed Name

Title

Signature of Owner (if different than Applicant)

Date

Printed Name

Title

Signature of Contact / Agent



Date

Printed Name

Title

For Agency Use Only

DETERMINATION OF NO PERMIT REQUIRED

Agency Application Number

(Agency Name) has determined that No Permit is required from this Agency for the project described in this application.

Agency Representative:

Printed Name

Title

Signature

Date

Supplemental Project Information

**Central Hudson Gas & Electric Corporation
Former North Water Street Manufactured Gas Plant, Poughkeepsie, New
York**

**Joint Application for Permit
U.S Army Corps of Engineers
New York State Department of Environmental Conservation
Supplemental Project Information**

Project Introduction

In accordance with Section 10 of the Rivers and Harbors Act and Section 401 of the Clean Water Act, Central Hudson Gas & Electric Corporation (CHGE) is submitting this Joint Application for Permit to the United States Army Corps of Engineers (USACE) and the New York State Department of Environmental Conservation (NYSDEC) for :

- Nationwide Permit (NWP)38 authorization, for “specific activities required to effect the containment, stabilization, or removal of hazardous or toxic waste materials that are performed, ordered, or sponsored by a government agency with established legal or regulatory authority;”
- Section 404 Clean Water Act; and
- 401 Water Quality Certification.

This attachment provides supplemental information to support the Joint Application for Permit submitted by CHGE for a Remedial Action (RA) at CHGE’s Former North Water Street Manufactured Gas Plant (MGP) site (site), pursuant to a Brownfield Cleanup Agreement (Index #D3-0004-99-04) and the March 2016 Decision Document issued by the NYSDEC (Site No. 314070). The site is located along the Hudson River in the City of Poughkeepsie, Dutchess County, New York. A Site Vicinity Map is provided as Attachment 2, Figure 1. The Decision Document is provided as Attachment 3.

Site Description and Existing Resources

The site is located at 2 Dutchess Avenue in the city of Poughkeepsie, Dutchess County, New York. Dutchess Avenue is located immediately north of the site, North Water Street and Amtrak railroad lines are located immediately east of the site, the Hudson River is located immediately west of the site, and the City of Poughkeepsie Upper Landing Park and Fall Kill Creek is located just south of the site. To the north of the site lies a property undergoing redevelopment. This adjacent property is the site of the former A.C. Dutton Lumber Yard (NYSDEC Site No. C314081) and was rezoned from industrial to waterfront district. The Site area of Poughkeepsie is zoned I-2, a general industrial district (Dutchess County Department of Planning and Development 2015).

The site is approximately 7 acres in size and is fenced on the northern, eastern and southern sides. Currently, CHGE operates a natural gas regulator station on the northwest portion of the site and an electric transition and substation on the southern/eastern portion of the Site. Most of the site has a gravel cover or is paved and topographic relief at the site ranges from approximately 5 feet (NGVD 1929) along the river to approximately 65 feet (NGVD 1929) along North Water Street. A north-south trending bedrock cliff is located approximately 100 feet east of the river, dividing the site into the upper (eastern) and lower (western) portions. The site abuts the Hudson River through the bulkhead. Tidal movements affect the Hudson River adjacent to the site. The Walkway over the Hudson state historic park crosses the Hudson River over the southern portion of the site. Current site features, known utilities, and Hudson River adjacent to the site are illustrated on the Figure 2 of the Attachment 2.

The site is located on the Hudson River, approximately 83 river miles (RM) north of New York Harbor, and 75 RM below the Federal Dam in Troy. The Hudson River is tidal below the Federal Dam. The extent of the salt wedge (100 milligrams per liter of chloride) occurs in the southern part of the Hudson River and may reach as far north as Poughkeepsie during very dry years (USGS, 2017).

The Hudson River adjacent to the site also contains the Significant Coastal Fish and Wildlife Habitat (SCFWH) area/Kingston Deepwater Habitat that encompasses a six mile stretch of the river extending approximately from Kingston in Ulster County south to the southern boundary of the Margaret Lewis Norrie State Park in Dutchess County. This habitat area is a nearly continuous deep water section of the river, from a water depth of 30 feet to the bottom, and especially where water depths of 50 feet or greater occur. The Kingston Deepwater Habitat is the northernmost extensive section of deep water habitat in the Hudson River and is depicted on the Figure 3 of the Attachment 2. No wetlands were found to be present on or near the site during the literature review as well as during a site inspection by a certified biologist.

Site Background

The site was operated as a carbureted water gas MGP from 1911 to 1950. CHGE has owned the site since 1926. During peak operation, waste by-products were recycled at the site, and during this process, by-products were reported to have seeped into the Hudson River from unintentional spills near the tar separator. To prevent additional seepage of by-products into the river, a clay dike was installed between the railroad siding and the river in the 1940s. Today, residuals from these releases are in the form of non-aqueous phase liquid (NAPL); more specifically dense non-aqueous phase liquid (DNAPL) is the primary form of site contamination to be addressed.

The NYSDEC- selected remedy to address the environmental impacts identified at the site and in the Hudson River adjacent to the site is presented in the March 2016 Decision Document. CHGE will be performing an environmental remediation at the site in accordance with the Brownfield Cleanup Agreement Index Number D3-0004-99-04 executed between CHGE and the NYSDEC in May 2005 and as required by the NYSDEC Decision Document.

Summary of Selected Remedy

The selected remedy for the site as documented in the NYSDEC Decision Document and as discussed and agreed upon in meetings with NYSDEC during pre-design investigations and remedial design generally includes:

- Excavation and off-site disposal of upland contamination from the source areas located in the northern portion of the lower terrace areas of the site (not part of this permit application).
- Installation of a subsurface barrier wall along the east bank of the Hudson River to prevent migration of coal tar to the River (not part of this permit application).
- Installation of a series of NAPL recovery wells behind the barrier wall to collect DNAPL that might accumulate behind the wall. NAPL will be collected from these recovery wells periodically (not part of this permit application).
- Installation of a NAPL recovery well in the area north of the barrier wall where the natural gas pipeline enters the upland portion of the site, which precludes the safe construction of the barrier wall. Initially in-situ solidification (ISS) was proposed for this area, but due to small size of this area, ISS is not practical. Installation of a NAPL recovery well in lieu of ISS in this area was presented to the NYSDEC during a meeting on November 8, 2017 to capture any NAPL that may be migrating towards the Hudson River (not part of this permit application).
- Dredging of NAPL impacted sediments from the bed of Hudson River where feasible.
- Placement of cover system consisting of Reactive Core-Mats (RCM) overlain by armored concrete blocks over the impacted sediment areas near and above the underwater utility crossings, where dredging cannot be performed.
- Placement of articulated capping system consisting of RCM with grout filled molds over the riverbank slope immediately adjacent to the site where dredging would create significant safety concerns due to potential for slope instability. The capping system will prevent migration of the remaining contamination in the riverbank into the Hudson River.
- Placement and maintenance of the cover system over the site to allow for industrial use of the site. The cover system will consist of structures, pavements, or soil cover in areas where the exposed soil will exceed the applicable Soil Cleanup Objectives (SCOs) (not part of this permit application).
- River and riverbank restoration that incorporate measures to maximize wildlife habitat while protecting energy infrastructure and allowing for potential future development of a public access walkway along the riverbank.
- Establishing institutional controls in the form of an environmental easement for the upland portion of the site. Institutional controls in the upland areas would be established to limit subsurface intrusive activities that could result in potential exposure to soil and groundwater, limit the use of the site, prohibit the use of the site groundwater, and require compliance with the Site Management Plan (SMP) (not part of this permit application).

- Preparing a SMP to document institutional controls, known locations of soil and sediments containing NAPL impacts, protocols for conducting intrusive activities, protocols for periodic monitoring, and reporting requirements(not part of this permit application).

Of the remedial activities listed above, the dredging and capping activities in the Hudson River and along the river side slope are subject to NWP 38 and described herein. Approximately 7.6 acres of dredging (Figure 3 of Attachment 2) will be conducted to remove approximately 38,000 cubic yards (CYs) of sediment impacted by the operation of the former MGP facility. Dredging of sediments that are visually impacted with NAPL from the areas identified on Figure 3 is anticipated to be conducted between October 2018 and February 2019. The less intrusive capping of the underwater utility crossings and river slope areas also shown on Figure 3 of Attachment 2 is anticipated to be conducted between July 2019 and September 2019, after the published key migratory spawning season (March 1 through June 30).

Description of Remedial Activities

Figures 1 through 11 of Attachment 2 provide the plans for the remedial action for the river slope along the site and portion of the Hudson River. The primary components of the remedial action are described below:

Mobilization and Site Preparation:

Mobilization will involve transporting the necessary equipment, materials, and personnel to the work area to implement the remedial action program after receipt of regulatory permits. Temporary facilities will be sized and located to ensure efficient material handling, staging and sequencing of the remedial activities. This will generally include office trailers, utility hookups, wash stations, etc. Site preparation will include: identifying the location of and protecting utilities, equipment, and structures; installing erosion and sedimentation control measures as needed; installing provisions for site security, and volatile emission, odor, and dust control; clearing vegetation and surface debris; constructing temporary site access roads and traffic controls; mobilizing barges and boats; establishing naval routes; installing temporary project support facilities, installing a wastewater treatment plant; and constructing temporary staging areas and decontamination areas.

Sediment Dredging

Dredging will be conducted within the areas depicted on the Figure 4 of Attachment 2 as delineated by the Decision Document, Remedial Alternative Analysis and Pre-Design Investigation to remove sediments saturated with NAPL. The figure also depicts vertical extent of the dredging below the current sediment surface to meet the remedial objective of removing NAPL-impacted sediments. The proposed dredge sections are depicted on Figure 5 of Attachment 2.

Targeted river sediments will be dredged using an environmental bucket, which is designed to provide flat dredge cuts for maximum control of the dredged surface while also utilizing seals to limit loss of material as the bucket is raised through the water column. All dredging will take

place within a containment cell mounted to the dredge barge. The containment cell will be outfitted with turbidity curtains and floating booms on all sides to control transport of contaminated sediments and NAPL, released during dredging, outside the work area. Figures 6A and 6B of Attachment 2 presents a conceptual dredge layout showing the dredge barge and dimensions of the turbidity curtain cell. Figure 6C of Attachment 2 presents the details of the proposed turbidity curtain of the containment cell section and its setup during dredging operations. Table 1 at the end of this document presents the surface are and dredge volume within each dredge area.

Water quality (turbidity) will be monitored for the duration of the dredging by means of three buoy-mounted remote sensing stations that will be moored around the perimeter of the work area. In addition, an engineer will provide visual confirmation of turbidity as well as presence of any sheen beyond the containment cell. A patrol boats will be stationed downstream of the work area to detect any turbidity or NAPL sheens. Oil containment booms and other control equipment will be present on the patrol boat to mitigate and/or control any turbidity or sheens. Based on the NYSDEC Decision Document, it is not anticipated that confirmation or documentation sampling, as defined by DER-10, will be required to confirm the excavation endpoint. The engineer will note the dredge buckets removing sediments from dredge prism sidewalls and bottom for presence of visible NAPL. The dredge prism will be expanded if NAPL is observed (within the sediments removed from the bottom and sidewall) or considered complete when design depths have been achieved. Depth confirmations will be provided via a GPS system installed on the dredge barge, with a land based total system.

Full scows will be transported to an on-site mooring for dewatering, where excess water will be transferred to a decant barge. Following dewatering, the material scows will be transported to an approved treatment and/or disposal facility for off-site stabilization, treatment, and disposal of dredged sediments. Tentative disposal facilities include Clean Earth of New Jersey located in Kearny, New Jersey, Bayshore Recycling located in Keasbey, New Jersey, and ESMI of New York located in Ford Edward, New York.

Restoration of Dredged Areas

Areas dredged deeper than 2 feet below the existing bathymetry will be backfilled after dredging with certified clean sand (approximately 31,000 CYs) imported from upland sources and transported to the site via barge. To minimize turbidity and allow accurate placement, the clean sand will be placed on approximately 4.2 acres of the dredged areas using specially fabricated conveyors and tremie technology that will discharge the sand from a tremie pipe. As shown in Figure 7 of Attachment 2, to the extent practicable, the tremie pipe will extend to the dredge surface

The clean sand backfill will be placed in the dredged areas to within 2 feet of the adjacent bottom elevation to support the restoration of the river bottom to pre-dredge bathymetry. Figure 7 of Attachment 2 also shows typical dredge and fill section details. The sand will consist of a granular material of sufficient size and density that is expected to fall through the portion of the water column beyond the tremie pipe to the river bottom at its placement location with minimal dispersion. Clean sand was selected specifically to maximize accuracy of the fill placement

operation and minimize suspension and transport of backfill material outside of the intended placement location.

The river bottom will be allowed to reestablish its original (pre-dredging) bathymetry within the dredged areas by natural sediment transport processes. Sediment deposition and subsequent erosion is a natural cycle within a stable riverbed. While specific rates of sedimentation and erosion in the vicinity of Poughkeepsie are not available, sedimentation rates of approximately 40 centimeters (1.3 feet) within a period of months (typically, during the spring freshet) are observed within the Lower Hudson River as a whole. Dredging of the impacted sediment will create areas of the river bottom below the surrounding bathymetry and function as natural sediment traps; consequently, it is expected that sediment transport within the dredged areas will only be depositional in nature until the pre-existing stable bathymetry is restored, after which the natural long-term deposition and erosion cycle will resume.

River Slope Grading and Capping

The slope of the shoreline along the site cannot be dredged to remove potentially impacted soils remaining between the bulkhead wall and the dredge area due to the riverbank stability concerns. A subsurface steel sheet pile wall will be installed as part of the upland and bulkhead remediation activities. To isolate the impacted sediment remaining beyond the sheet pile bulkhead wall from the river, an approximately 1.22 acre area of the river slope will be graded and an articulated capping system consisting of RCM with grout filled molds will be installed along the river slope. The new river slope of 2H:1V will be maintained to provide stability to the slope and to minimize exposed sheet pile bulkhead as requested by the NYSDEC. This would require a cut volume of 1,722 CY and a backfill volume of approximately 6,775 CY. Figures 8, 9A, and 9B provide plan and cross-sectional views of the proposed river slope grading activities.

A cap will be constructed using an innovative subaqueous forming system (articulated cap) where interlocking fabric molds attached to organoclay RCMs are assembled on land in large segments, and then placed on the slope. Once placed on the slope, the individual segments will be interlocked by a diver and grout will be pumped into the molds via tremie lines. As the fabric molds “inflate” with grout, the interlocks become buried within the grout, eventually producing a stable, continuous 6-inch cap. Figure 10 of Attachment 2 presents conceptual details of the proposed river slope cap.

The underlying RCMs provide a highly adsorptive isolation layer, which controls migration of residual DNAPL out of the slope. In some areas additional RCMs may be included to provide additional control of residual NAPL. The articulated cap will be anchored on the top of the River Slope via placement of riprap as shown in Figure 10 of Attachment 2.

Utility Crossing Area Cap

Since dredging cannot be conducted in the area of active underwater gas, fiber optic, and electric lines that extend across the Hudson River, approximately one acre of area near and over the utility crossings will be capped with a cover system consisting of RCM overlain by

premanufactured armored concrete blocks to isolate the impacted sediment in these areas (Figure 3 of Attachment 2).

Similar to the river slope cap slope, these assemblies will be largely constructed on land and then placed in large segments, limiting the quantity of subaqueous work required for installation. The RCM provides control of residual NAPL migration beneath the cap, while the armor mats protect the utility from damage. Figure 3 of attachment 2 presents the cap layout plan for the utility crossing area, while the Figure 11 presents details of the components of the proposed cap.

Best Management Practices/Engineering Controls

To minimize impacts to Hudson River during the implementation of the remedial activities, best management practices (BMPs) will be implemented prior to the start of work. Multiple lines of BMPs are proposed for implementation of this project. The BMPs are comprehensive, state of the art, and include types of controls successfully used at other environmental remediation projects to minimize impacts to riverine systems such as the Hudson River. The various BMPs include:

- **Environmental Bucket**: Targeted river sediments will be dredged using an environmental bucket, which is designed to provide flat dredge cuts for maximum control of the dredged surface while also utilizing seals to limit loss of material as the bucket is raised through the water column.
- **Containment Cells**: Water-based (resuspension) control measures will be installed prior to performing any intrusive activities in the Hudson River (e.g., debris removal, dredging). All dredging will take place within a containment cell mounted to the dredge barge. The containment cell will be outfitted with turbidity curtains and floating booms on all sides to control transport of contaminated sediments and NAPL, released during dredging, outside the work area. This innovative system ensures containment of dredge activity on all sides providing a comprehensive control system. Figure 6A of Attachment 2 presents a dredge layout showing the dredge barge and dimensions of the turbidity curtain cell. Figure 6B and 6C of Attachment 2 presents the details of the proposed containment cell section prior to setup and during operations. Figure 6B presents a typical cross section of the containment cell with the proposed turbidity curtain. The turbidity curtain will be weighted down with the galvanized steel chain ballast and will extend to the bottom of the river to contain all dredge area sediments within the containment cell. As shown on the Figure 6B and 6C, the bottom 10 feet of the turbidity curtain will have an impermeable polyvinyl chloride (PVC) coating to minimize escape of sediments out of the containment cell and the top 10 feet of the curtain will also have an impermeable PVC coating to minimize escape of sheen out of the containment cell. The middle portion of the turbidity curtain will be constructed of woven fabric to allow flow of water while minimizing transfer of sediments. The containment assembly will be lifted slightly and moved to the next dredge location upon completion of dredging in one area. Frequent and periodic inspection and maintenance of the containment cell will take place during the duration of the sediment dredging activities.
- **Work Area Surface Water Monitoring**: Visual surface water monitoring will occur throughout the dredging and backfilling operation by an AECOM personnel present on the dredge barge. The AECOM personnel will provide visual confirmation of turbidity as well as presence of any sheen beyond the containment cell.

- Downstream Surface Water Monitoring: A patrol boat, equipped with oil absorbent and containment booms, will be available downstream of the work area to visually inspect the surface water and mitigate any sheens observed.
- Turbidity Monitoring: A turbidity monitoring program will be performed during the sediment removal and backfilling activities. Water quality (turbidity) will be monitored for the duration of the dredging by means of three buoy-mounted remote sensing stations that will be moored around the perimeter of the work area to confirm that the containment cell is functioning properly. Turbidity will be measured at an upstream location, near the work zone, and a downstream location.
- Inspections: Inspections of the water-based controls will be conducted each day at the beginning of intrusive activities. Inspections will also be conducted, as appropriate, in response to visible sediment plumes migrating from the work area or measured turbidity levels above the action level of 50 nephelometric turbidity units (NTUs) above the turbidity level at the upstream monitoring location. Inspections in response to turbidity levels above the action level metric will begin by re-sampling the downstream location to determine if the prior result was an anomaly or if the elevated reading was a result of a short duration event. If the exceedance is not an anomaly then contingency measures will be implemented. A Construction Quality Assurance Plan (CQAP) will identify contingency measures to meet turbidity action levels. Contingency measures may include:
 - Surface inspection (e.g., by boat) to determine condition of dredging containment system and address (e.g., repair) noted deficiencies.
 - If the cause of the turbidity exceedance cannot be determined through surface inspection (i.e., no visible damage, breach, tear, or dislocation), a hand-held turbidity meter or other appropriate method will be used to further investigate the cause of the turbidity increase.
 - Evaluation and modification to dredge operations (e.g. fall height, cycle time, bucket handling procedures, use of a rinse tank, etc.) or modifications of the containment cell.

Project Review Requirements

Pursuant to authorization under NWP 38, the following project reviews are required. Approval letters and/or requests for project review are included as attachments to this Joint Application for Permit:

Federal Consistency Assessment Review. The project requires review by the New York State Department of State to assess the project's consistency with the New York State Coastal Management Program. The completed Federal Consistency Assessment Form and supplemental project site information is provided as Attachment 5.

New York State Historic Preservation Office (SHPO) Review. In accordance with Section 106 of the National Historic Preservation Act and Section 14.09 of the New York State Parks, Recreation and Historic Preservation Law, a project site review by the New York SHPO and review application is provided as Attachment 6. Recommendation by New York SHPO to collect additional information is complete and a response to the review is in draft.

New York Natural Heritage Program Review. In accordance with the New York Environmental Conservation Law, review of the project site by the New York State Natural Heritage Program for information on endangered and threatened species is provided as Attachment 8.

National Marine Fisheries Service Review. In accordance with Section 7 of the Endangered Species Act of 1973, consultation with the National Marine Fisheries Service (NMFS) is provided as Attachment 9.

U.S. Fish and Wildlife Service Review. In accordance with the Fish and Wildlife Coordination Act of 2002, consultation with the U.S. Department of Interior, Fish and Wildlife Service is provided as Attachment 10.

Abbreviated Essential Fish Habitat (EFH) Assessment. In compliance with the Magnuson-Stevens Fishery Conservation and Management Act (1996 amendments), Section 7 of the Endangered Species Act of 1973 (as amended), and the Fish and Wildlife Coordination Act of 2002 (as amended), an Abbreviated EFH Assessment is provided as Attachment 11.

Biological Assessment. In accordance with the Section 7 of the Endangered Species Act of 1973 (16 United States Code [U.S.C.] 1531–1534) a biological assessment is prepared for the proposed remedial activities at the site and is provided as Attachment 12.

Stormwater Discharge Permit Equivalent

In compliance with Section 402 of the Clean Water Act, approval is required for stormwater discharges associated with an industrial activity from a point source to waters of the United States. The proposed stormwater discharge from the remediation site to the Hudson River will be authorized by the NYSDEC Division of Environmental Remediation as part of the remediation program.

NYSDEC Review of the Proposed Project

All work associated with the remedial activities will be conducted in accordance with a NYSDEC-approved remedial design, and applicable Federal and State issued permits. A representative of the NYSDEC Division of Environmental Remediation will provide general oversight during the remediation activities. Following the implementation of the remedial activities, a Final Engineering Report will be submitted to the NYSDEC Division of Environmental Remediation for review and approval.

Environmental Permitting Waivers

State Pollutant Discharge Elimination System (SPDES) Stormwater General Permit for Construction Activities. The remedial activities will result in earth disturbance of one acre or more. Per the guidance document of the SPDES program (“Frequently Asked Questions,” Version 3.0, September 12, 2006), hazardous waste site remediation projects do not need to obtain permit coverage under the SPDES Stormwater General Permit for Construction Activities (required for projects with earth disturbance of one acre or more), provided a site-specific Stormwater Pollution Prevention Plan (SWPPP) is prepared. A SWPPP will be prepared and retained on site through the duration of the remediation activities.

**Table 1
Breakdown of Approximate Dredge Areas, Volumes, and Thicknesses**

Dredge Prism	Prism Surface Area (sf)	Prism Surface Area (acre)	Dredge Volume (cy)	Deepest Dredge Design Thickness (ft)
1	52,185	1.20	1,944	1
2	16,213	0.37	1,224	2
3	17,593	0.40	715	1
4	9,471	0.22	1,209	4
5	9,290	0.21	396	1
6	3,785	0.09	291	2
7	3,846	0.09	508	4
8	18,534	0.43	3,682	6
9	6,189	0.14	592	1
10	6,194	0.14	1,781	10
11	19,036	0.44	1,273	1
12	12,196	0.28	2,386	6
13	3,278	0.08	545	4
14	17,104	0.39	5,039	8
15	4,278	0.10	1,005	8
16	6,565	0.15	2,830	13
17	7,418	0.17	928	2
18	3,023	0.07	353	2
19	3,963	0.09	1,063	8
20	5,100	0.12	745	4
21	5,614	0.13	1,210	6
22	6,436	0.15	2,162	10
23	12,165	0.28	1,989	4
24	18,144	0.42	1,192	1
25	18,478	0.42	704	1
26	18,538	0.43	692	1
27	3,959	0.09	148	1
28	34,124	0.78	1,253	1
River Slope	53,143	1.22	1,722	Variable

Total	344392	9.09	39,582
-------	--------	------	--------

Attachment 2
Location Map and Site Plans

File: P:\Jobs\Rem_Eng\Project Files\CHGE\900 CAD\910 CAD\20 SHEETS\PDF\Permitting 2\Permitting Figures.dwg Layout: VICINITY MAP User: erica.hart Plotted: Jan 11, 2018 - 10:06am Xref's:

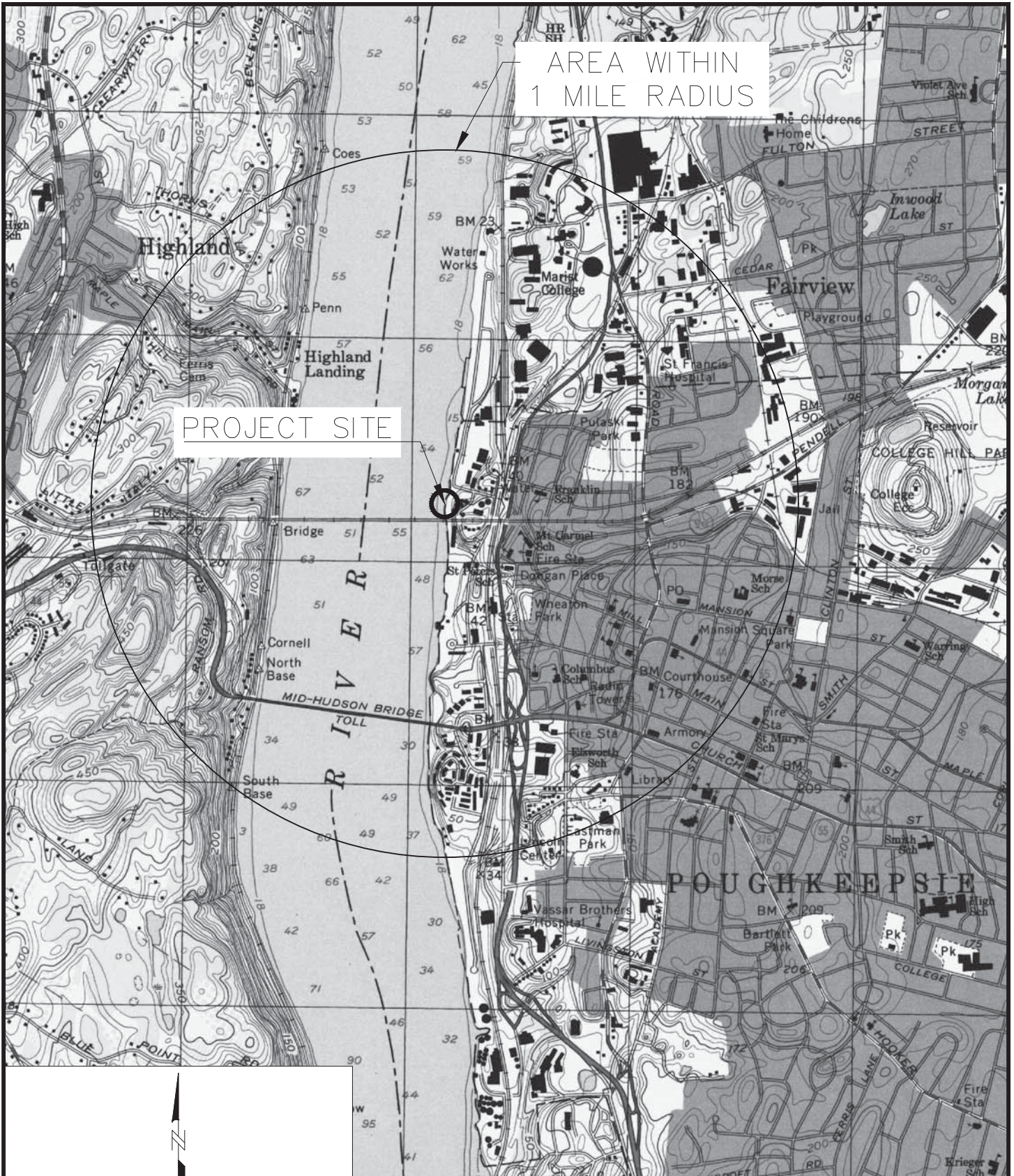

AREA WITHIN
1 MILE RADIUS

PROJECT SITE

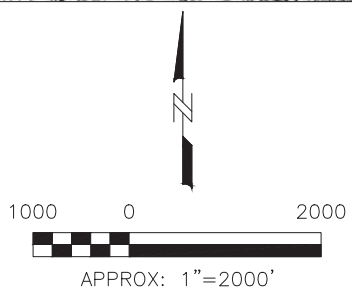

Map Source: U.S.G.S. 7.5' Quadrangle, Poughkeepsie, NY

For Agency Review Only



CENTRAL HUDSON GAS & ELECTRIC
HUDSON RIVER
DUTCHESS COUNTY, NY

VICINITY MAP
FORMER NORTH WATER STREET MGP
POUGHKEEPSIE

DATE: 1/11/18

FIGURE 1 OF 11

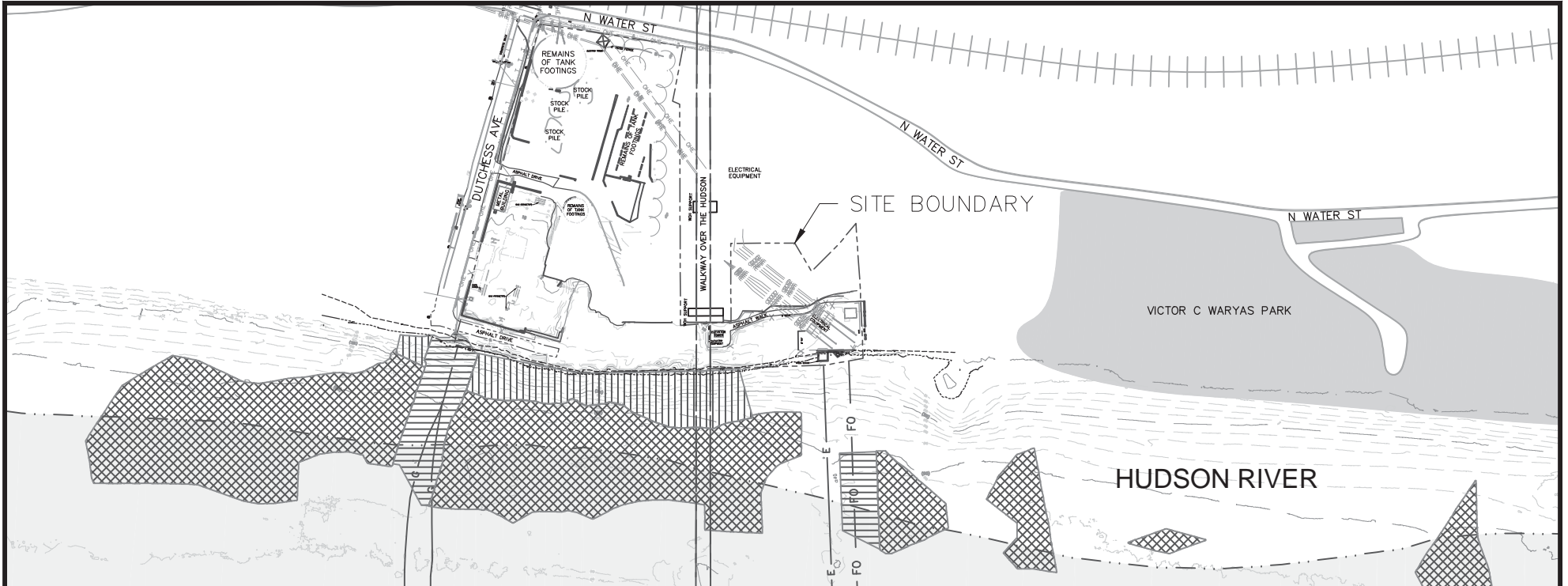

LEGEND

- | | | | |
|--|-------------------------|--|-----------------------------|
| | RAILWAY TRACKS | | |
| | GAS LINE | | PROPOSED SLOPE GRADING AREA |
| | ELECTRIC LINE | | PROPOSED UTILITY CAP AREA |
| | FIBER OPTIC LINE | | DREDGE AREA |
| | OVERHEAD ELECTRIC LINE | | |
| | EDGE OF WALKWAY | | |
| | SITE BOUNDARY | | |
| | EXISTING FENCE | | |
| | EDGE OF WOODS | | |
| | SCFWH AREA BOUNDARY | | |
| | MEAN HIGH WATER (1.93') | | |
| | MEAN LOW WATER (-1.58') | | |

KINGSTON-POUGHKEEPSIE DEEPWATER SCFWH AREA

For Agency Review Only

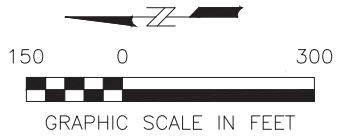

CENTRAL HUDSON GAS & ELECTRIC
HUDSON RIVER
DUTCHESS COUNTY, NY
DATE: 1/11/18

REMEDIAL ACTIVITIES PLAN
FORMER NORTH WATER STREET MGP
POUGHKEEPSIE, NY
FIGURE 3 OF 11

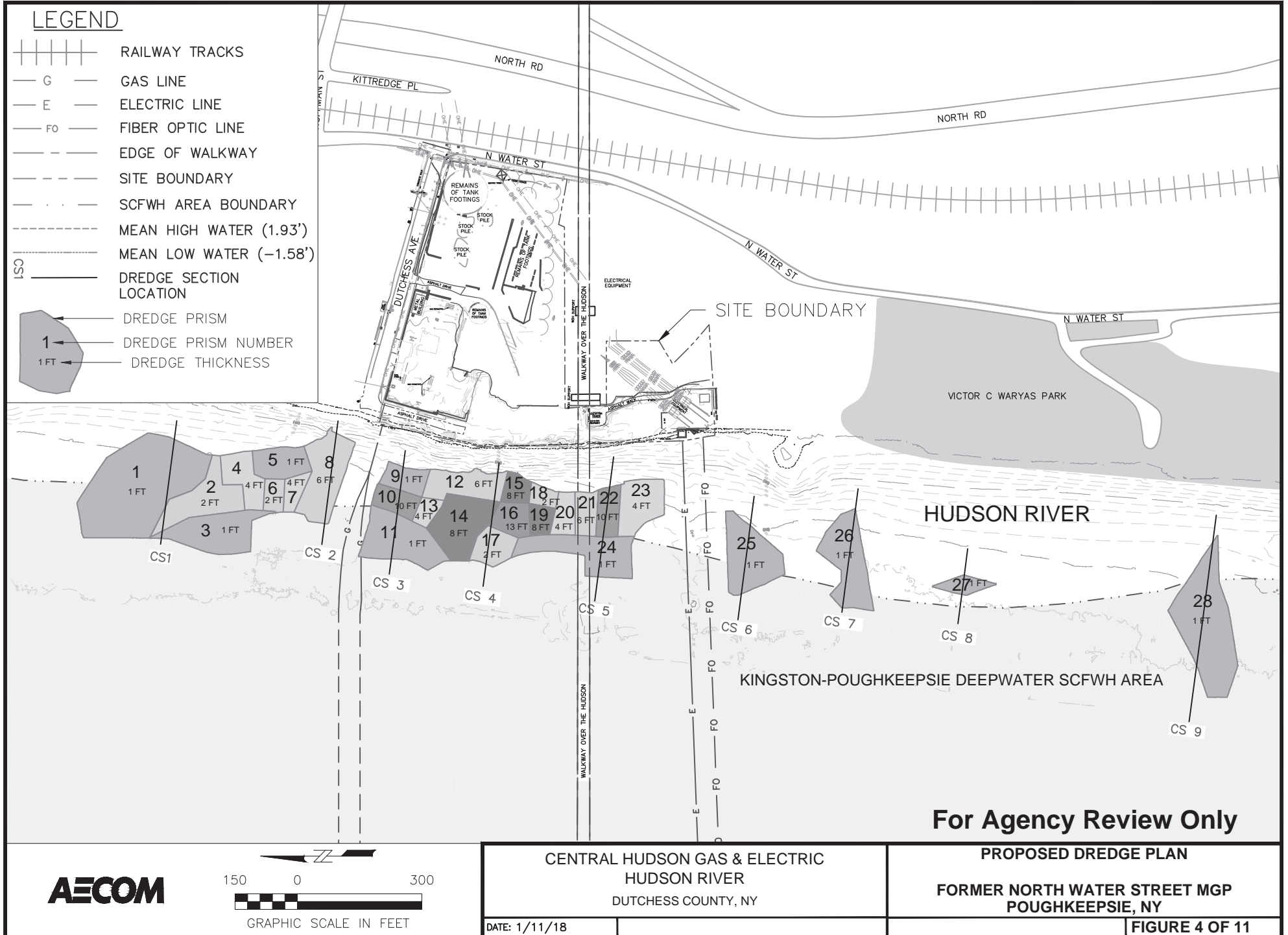

DREDGE SECTION 2

DREDGE SECTION 1

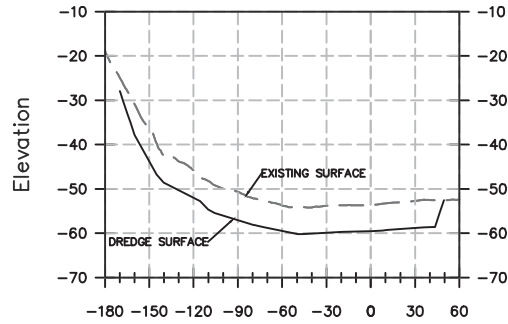
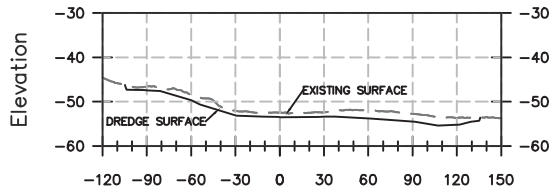

DREDGE SECTION 3

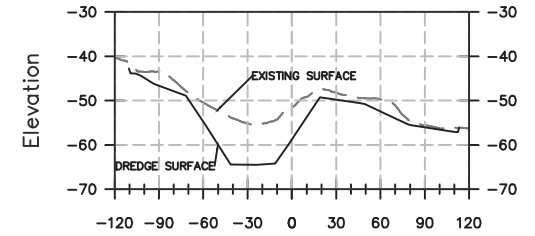

DREDGE SECTION 4

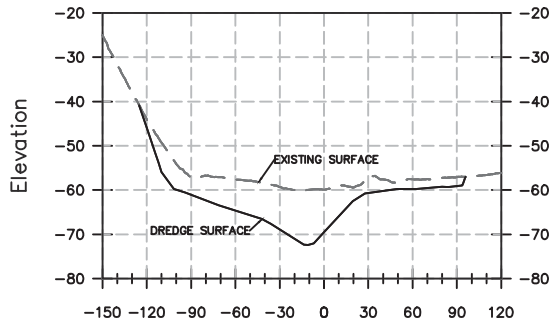

DREDGE SECTION 5

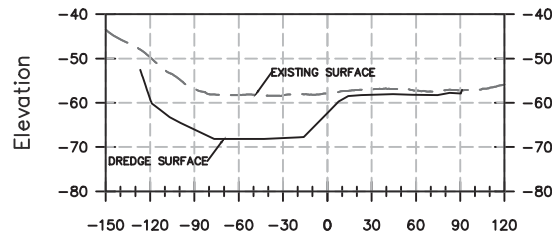

DREDGE SECTION 6

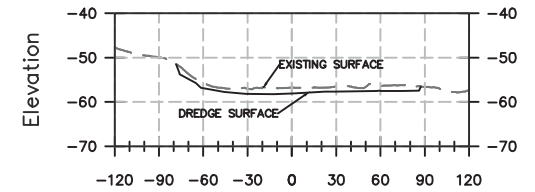

DREDGE SECTION 7

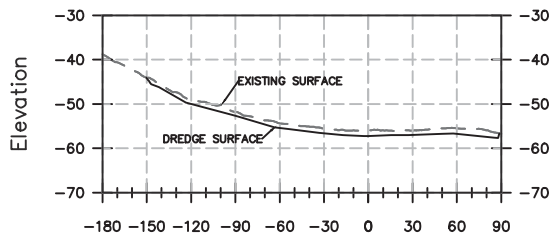

DREDGE SECTION 8

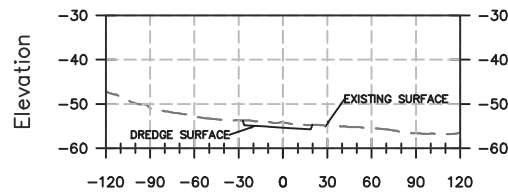

DREDGE SECTION 9

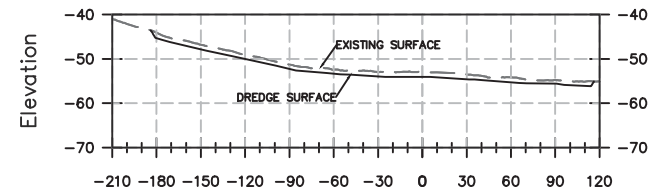

For Agency Review Only



CENTRAL HUDSON GAS & ELECTRIC
HUDSON RIVER
DUTCHESS COUNTY, NY

PROPOSED DREDGE PLAN
CROSS SECTIONS
FORMER NORTH WATER STREET MGP
POUGHKEEPSIE, NY

DATE: 1/11/18

FIGURE 5 OF 11

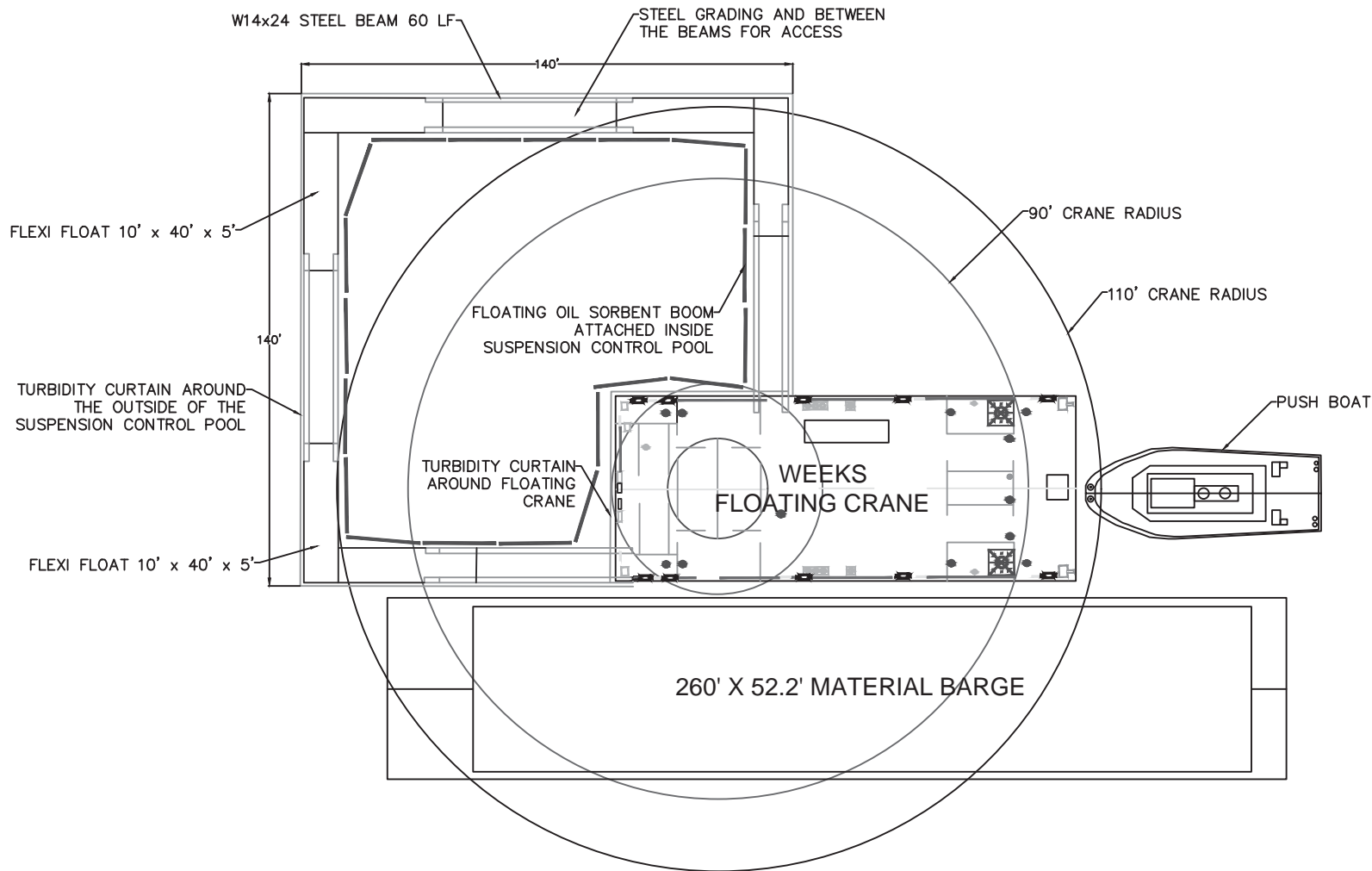

MOBILE SUSPENSION CONTROL SYSTEM SETUP OVERVIEW

NOTE: FIGURES NOT DRAWN TO SCALE. THESE ARE CONCEPTUAL DRAWINGS.

For Agency Review Only



CENTRAL HUDSON GAS & ELECTRIC
HUDSON RIVER
DUTCHESS COUNTY, NY

ENGINEERING CONTROLS
PLAN VIEW
FORMER NORTH WATER STREET MGP
POUGHKEEPSIE, NY

DATE: 1/11/18

FIGURE 6A OF 11

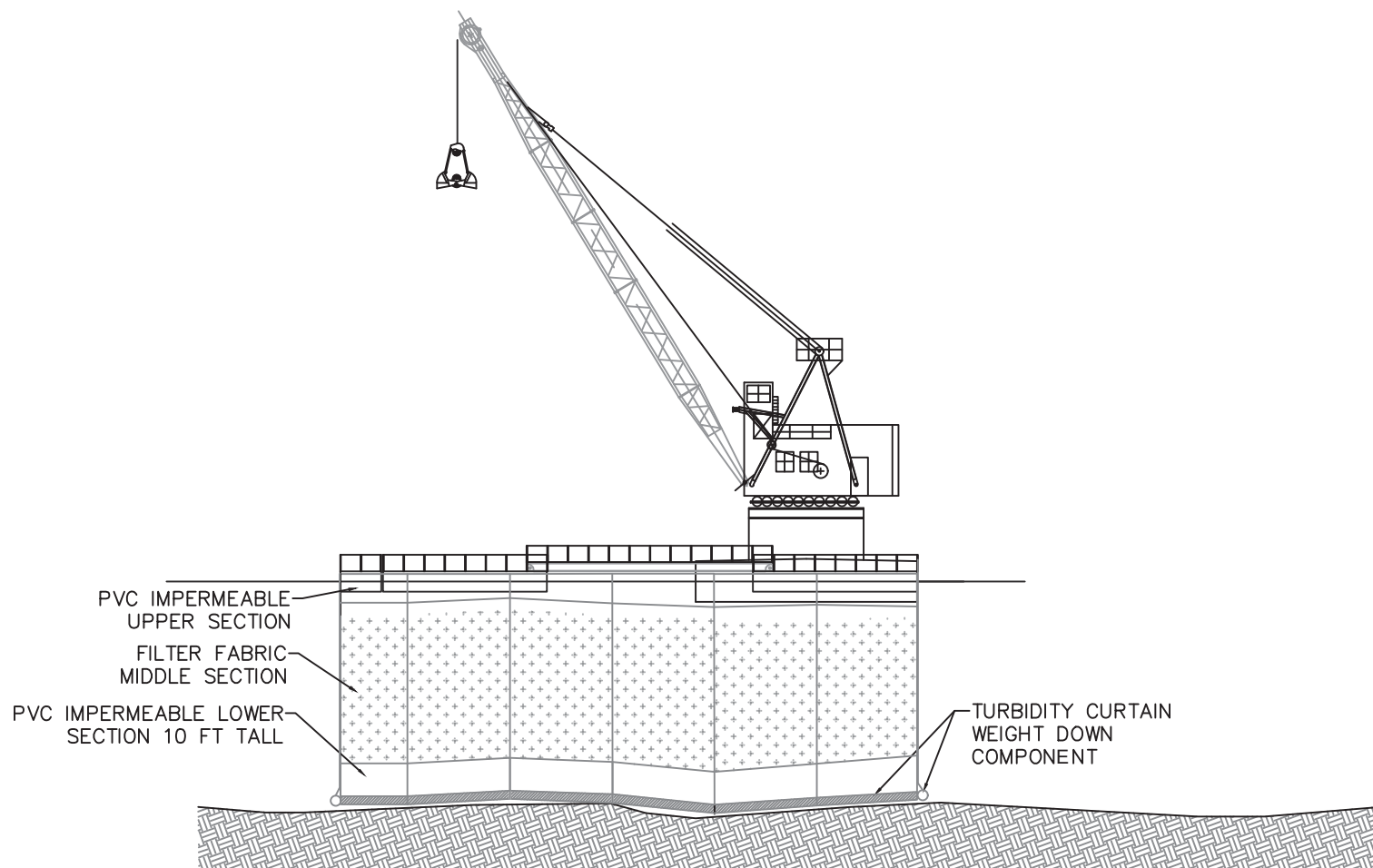

MOBILE SUSPENSION CONTROL SYSTEM SETUP
FRONT VIEW

NOTE: FIGURES NOT DRAWN TO SCALE. THESE ARE CONCEPTUAL DRAWINGS.

For Agency Review Only



CENTRAL HUDSON GAS & ELECTRIC
HUDSON RIVER
DUTCHESS COUNTY, NY

ENGINEERING CONTROLS
SIDE VIEW
FORMER NORTH WATER STREET MGP
POUGHKEEPSIE, NY

DATE: 1/11/18

FIGURE 6B OF 11

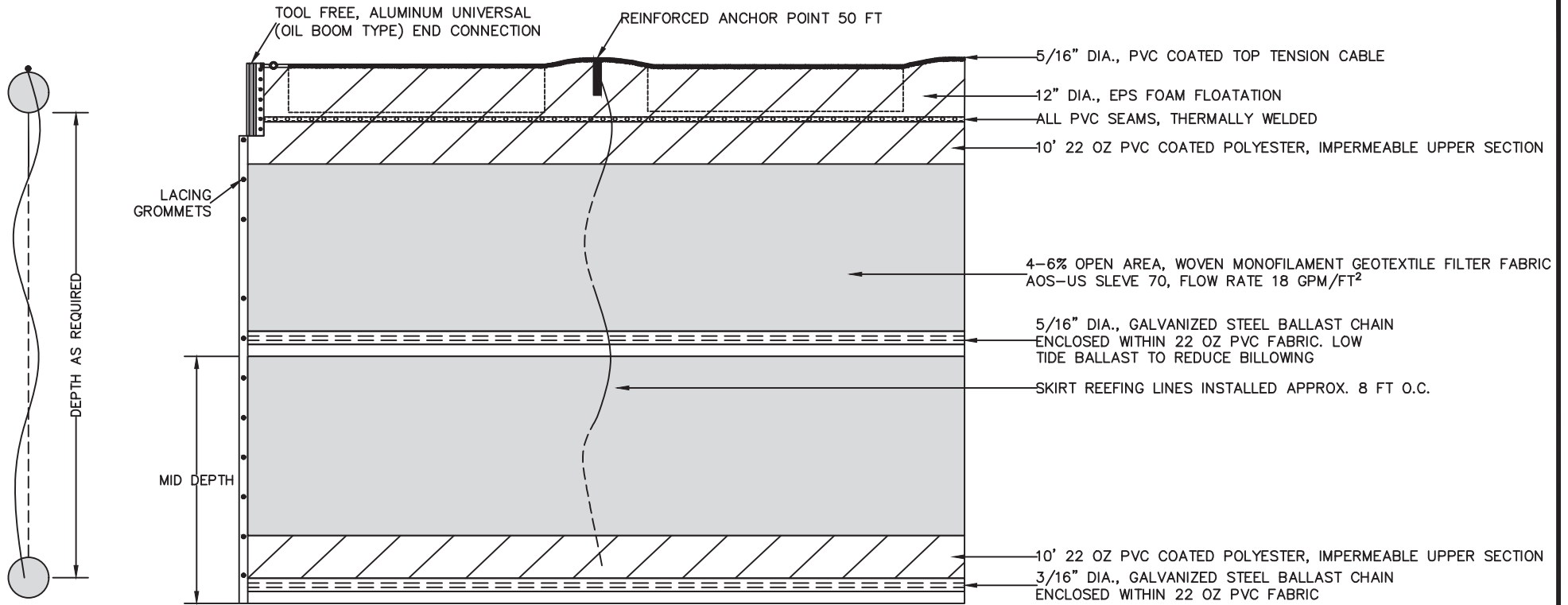

TURBIDITY BARRIER DETAIL

NOTE: FIGURES NOT DRAWN TO SCALE. THESE ARE CONCEPTUAL DRAWINGS.

For Agency Review Only



CENTRAL HUDSON GAS & ELECTRIC
HUDSON RIVER
DUTCHESS COUNTY, NY

ENGINEERING CONTROLS
DETAIL
FORMER NORTH WATER STREET MGP
POUGHKEEPSIE, NY

DATE: 1/11/18

FIGURE 6C OF 11

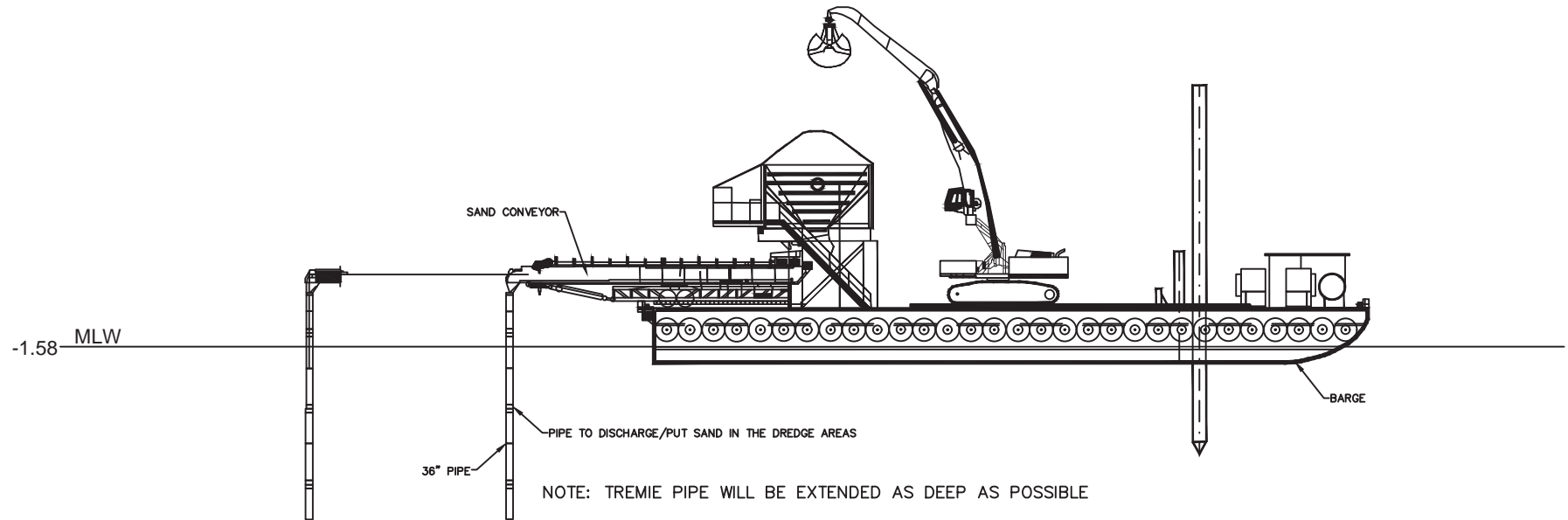

CONCEPTUAL DREDGE RESTORATION OPERATION

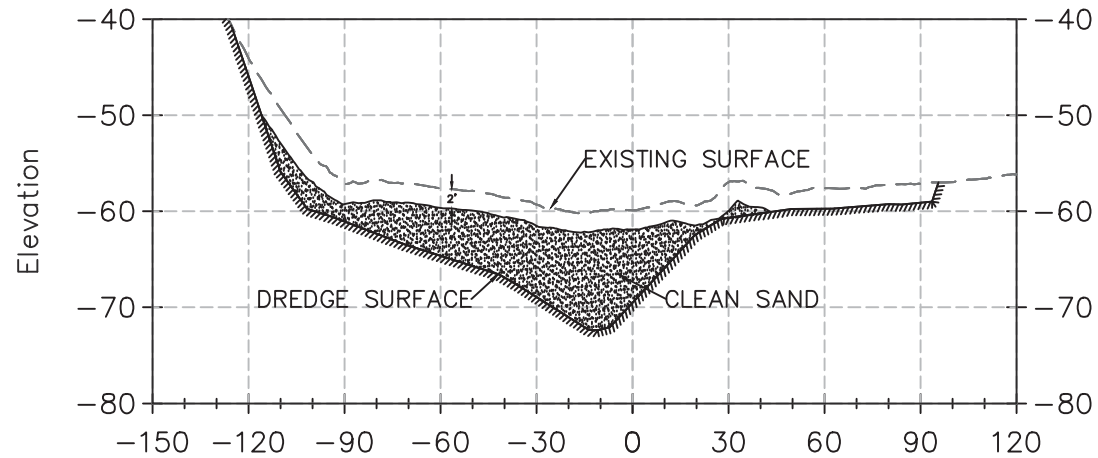

For Agency Review Only



CENTRAL HUDSON GAS & ELECTRIC
HUDSON RIVER
DUTCHESS COUNTY, NY

DREDGE AREA RESTORATION PLAN
FORMER NORTH WATER STREET MGP
POUGHKEEPSIE, NY

DATE: 1/11/18

FIGURE 7 OF 11

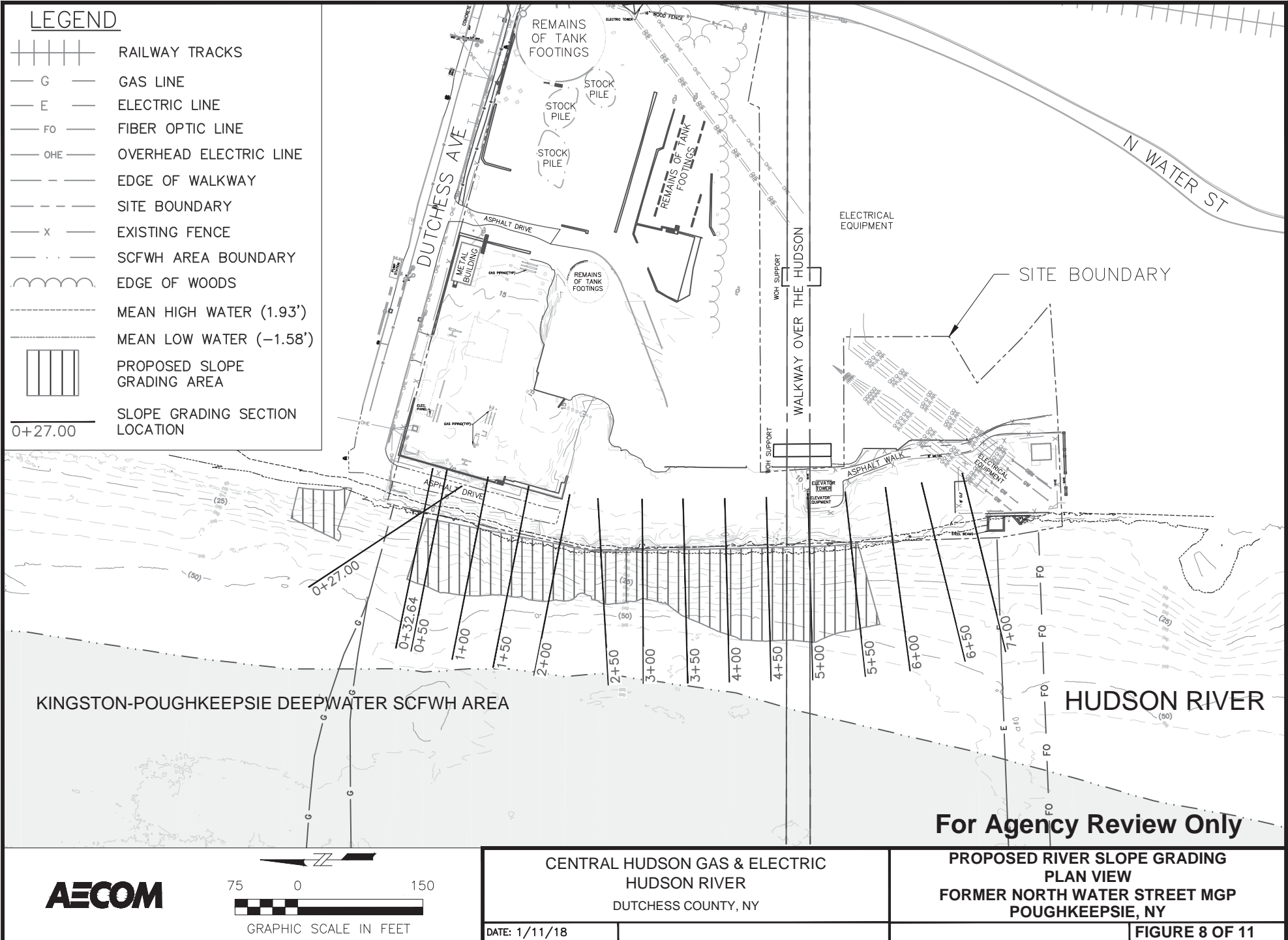

LEGEND

- ORIGINAL SLOPE SURFACE
- RESTORED CAP SURFACE
- · - · - DREDGE SURFACE
- - - - - MEAN HIGH WATER (1.93')
- MEAN LOW WATER (-1.58')

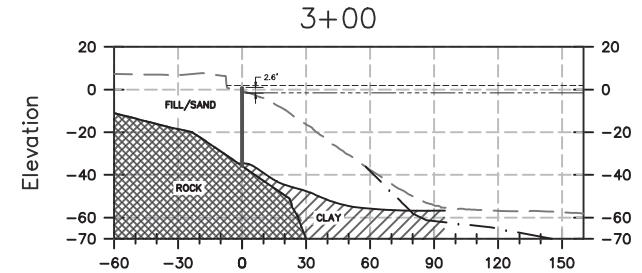
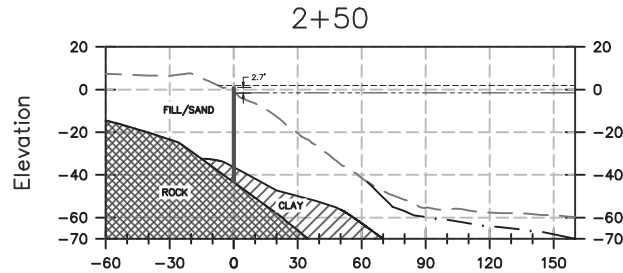
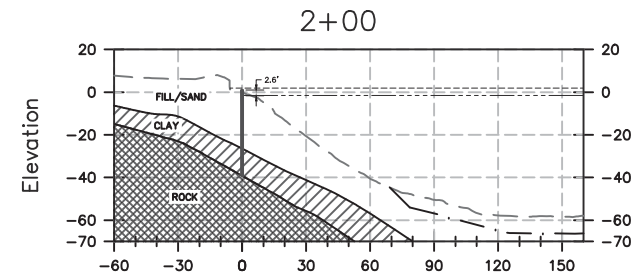
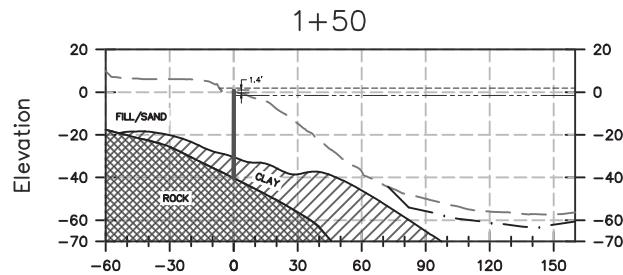
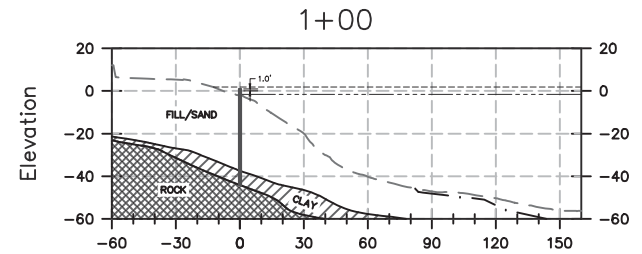
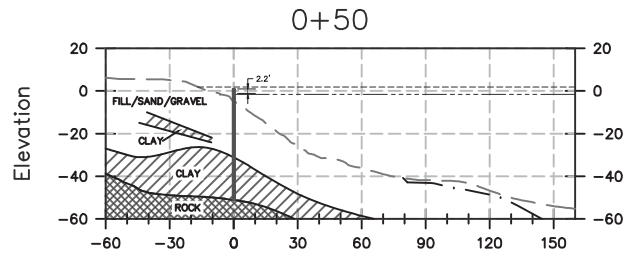
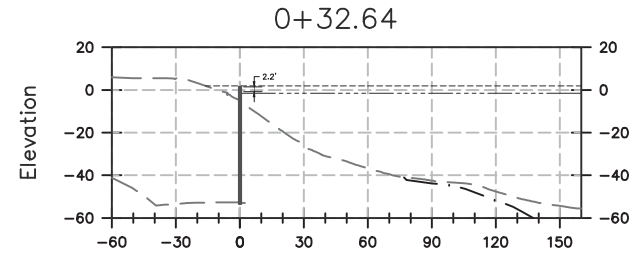
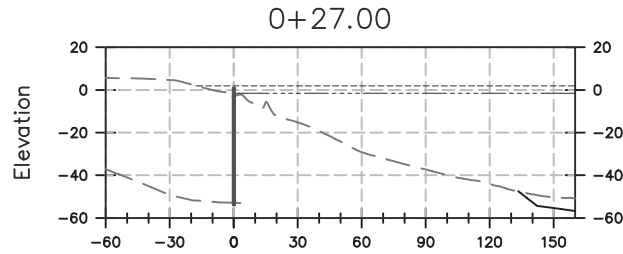

For Agency Review Only



CENTRAL HUDSON GAS & ELECTRIC
HUDSON RIVER
DUTCHESS COUNTY, NY

PROPOSED RIVER SLOPE GRADING
CROSS SECTIONS
FORMER NORTH WATER STREET MGP
POUGHKEEPSIE, NY

DATE: 1/11/18

FIGURE 9A OF 11

LEGEND

- ORIGINAL SLOPE SURFACE
- RESTORED CAP SURFACE
- · - · - DREDGE SURFACE
- - - - - MEAN HIGH WATER (1.93')
- MEAN LOW WATER (-1.58')

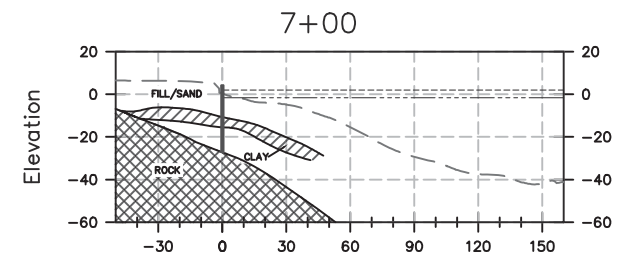
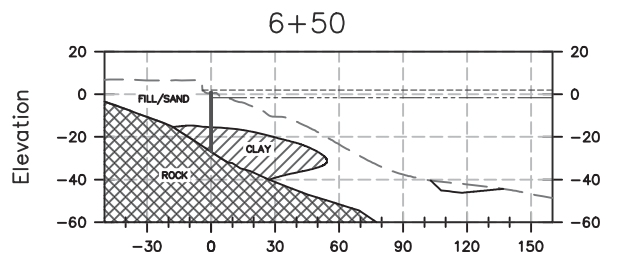
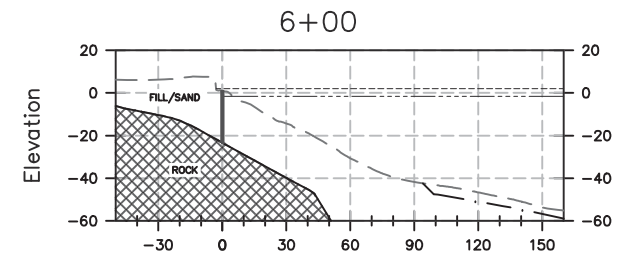
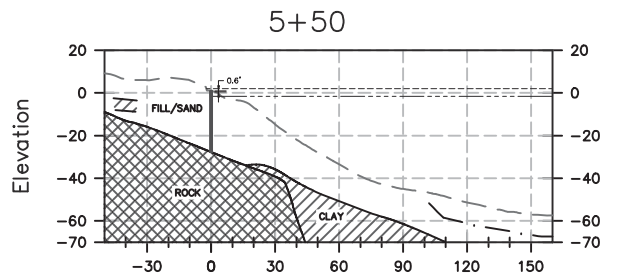
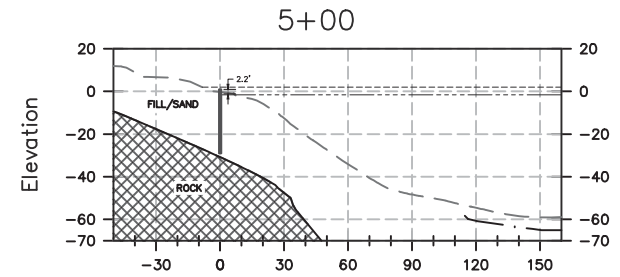
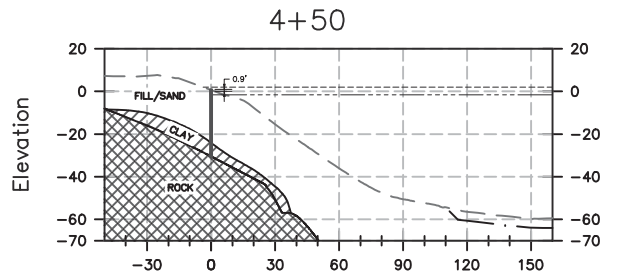
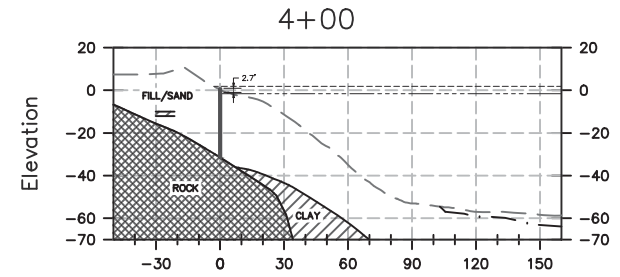
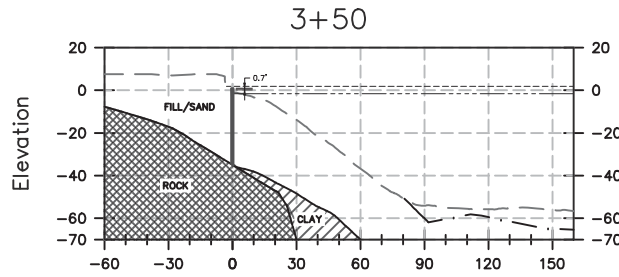

For Agency Review Only



CENTRAL HUDSON GAS & ELECTRIC
HUDSON RIVER
DUTCHESS COUNTY, NY

PROPOSED RIVER SLOPE GRADING
CROSS SECTIONS
FORMER NORTH WATER STREET MGP
POUGHKEEPSIE, NY

DATE: 1/11/18

FIGURE 9B OF 11

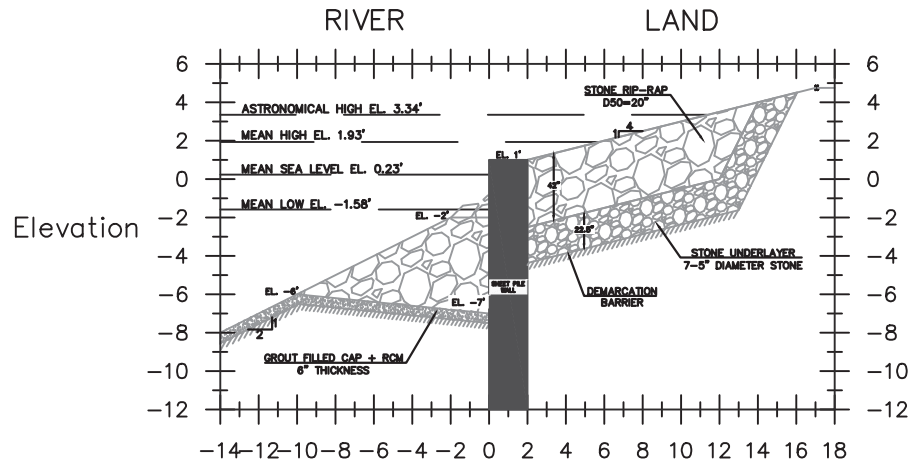

PROPOSED SIDE SLOPE RESTORATION

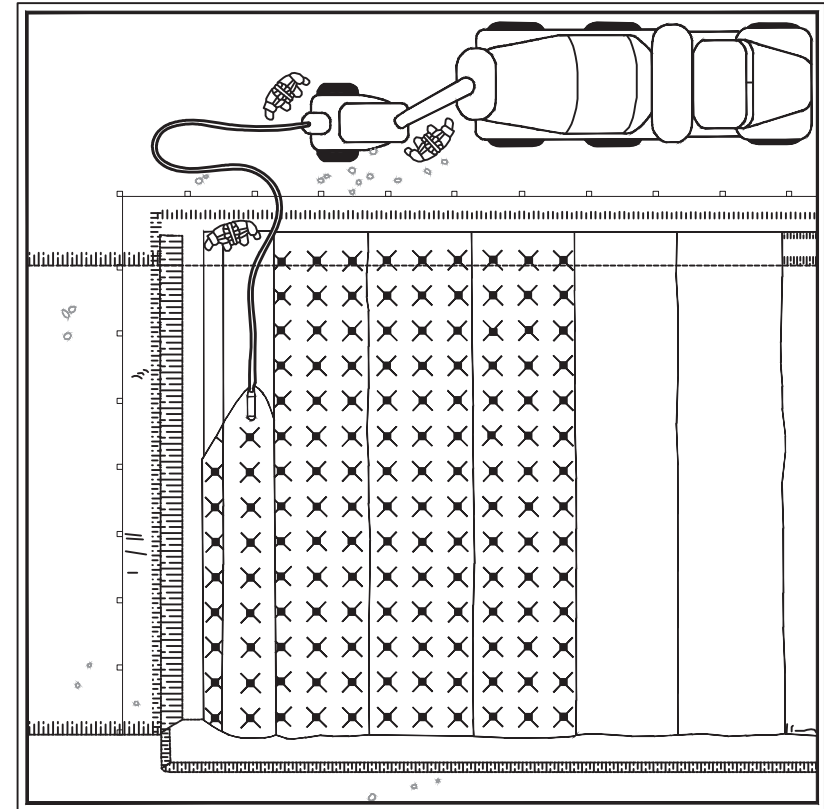

REACTIVE CORE MAT OVERLAID WITH CONCRETE MATTRESSES
ISOMETRIC VIEW

For Agency Review Only



CENTRAL HUDSON GAS & ELECTRIC
HUDSON RIVER
DUTCHESS COUNTY, NY

DETAILS FOR SIDE SLOPE CAP
FORMER NORTH WATER STREET MGP
POUGHKEEPSIE, NY

DATE: 1/11/18

FIGURE 10 OF 11

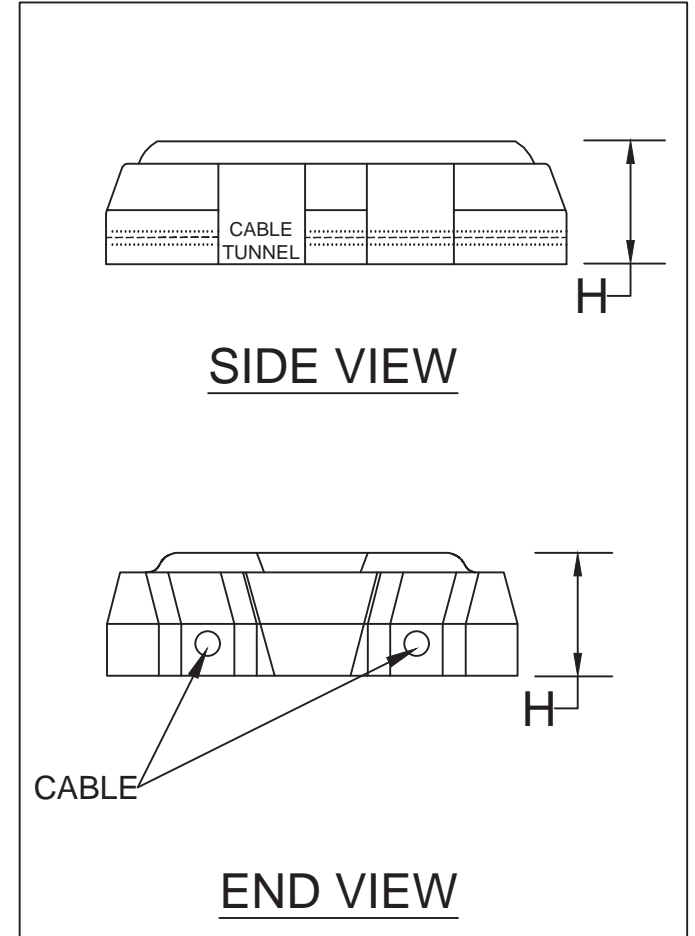
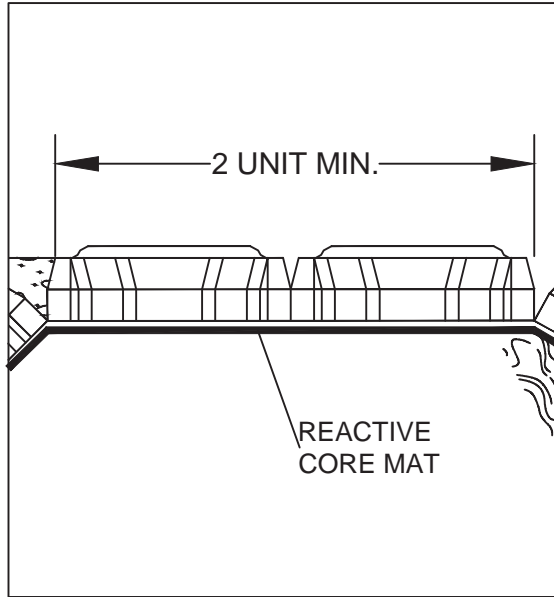
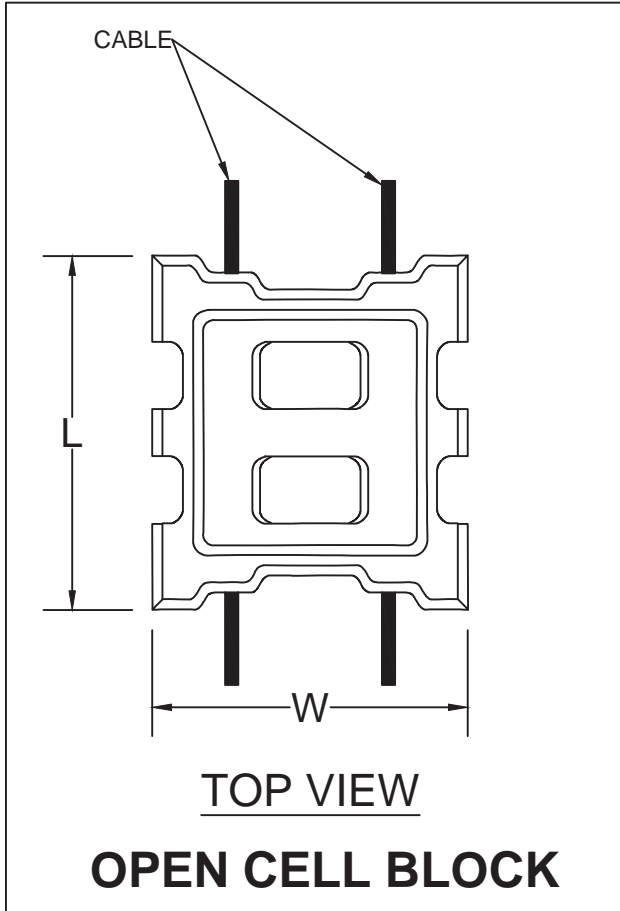

CENTRAL HUDSON GAS & ELECTRIC
HUDSON RIVER
DUTCHESS COUNTY, NY

DATE: 1/11/18

For Agency Review Only

DETAILS FOR UTILITY CAP
FORMER NORTH WATER STREET MGP
POUGHKEEPSIE, NY

FIGURE 11 OF 11

Attachment 3

NYSDEC Decision Document

DECISION DOCUMENT

CH - Water St. - Poughkeepsie MGP
Brownfield Cleanup Program
Poughkeepsie, Dutchess County
Site No. C314070
March 2016



Prepared by
Division of Environmental Remediation
New York State Department of Environmental Conservation

DECLARATION STATEMENT - DECISION DOCUMENT

CH - Water St. - Poughkeepsie MGP
Brownfield Cleanup Program
Poughkeepsie, Dutchess County
Site No. C314070
March 2016

Statement of Purpose and Basis

This document presents the remedy for the CH - Water St. - Poughkeepsie MGP site, a brownfield cleanup site. The remedial program was chosen in accordance with the New York State Environmental Conservation Law and Title 6 of the Official Compilation of Codes, Rules and Regulations of the State of New York (6 NYCRR) Part 375.

This decision is based on the Administrative Record of the New York State Department of Environmental Conservation (the Department) for the CH - Water St. - Poughkeepsie MGP site and the public's input to the proposed remedy presented by the Department.

Description of Selected Remedy

The elements of the selected remedy are as follows:

1. A remedial design program will be implemented to provide the details necessary for the construction, operation, optimization, maintenance, and monitoring of the remedial program. Green remediation principles and techniques will be implemented to the extent feasible in the design, implementation, and site management of the remedy as per DER-31. The major green remediation components are as follows;

- Considering the environmental impacts of treatment technologies and remedy stewardship over the long term;
- Reducing direct and indirect greenhouse gases and other emissions;
- Increasing energy efficiency and minimizing use of non-renewable energy;
- Conserving and efficiently managing resources and materials;
- Reducing waste, increasing recycling and increasing reuse of materials which would otherwise be considered a waste;
- Maximizing habitat value and creating habitat when possible;
- Fostering green and healthy communities and working landscapes which balance ecological, economic and social goals; and
- Integrating the remedy with the end use where possible and encouraging green and sustainable re-development.

2. Excavation and off-site disposal of upland contaminant source areas, located in the northern portion of the lower terrace area, to include:

- grossly contaminated soil, as defined in 6 NYCRR Part 375-1.2(u);
- removal of all underground MGP structures and underground piping; and
- soil containing visual coal tar or non-aqueous phase liquid;

3. Barrier Wall:

A subsurface barrier wall will be installed along the east bank of the Hudson River to prevent the migration of coal tar to the river. The wall will be constructed along the eastern bank of the river from the gas utility crossing immediately south of Dutchess Ave to a point approximately 450 feet to the south, where the walkway over the Hudson extends above the site. The wall will extend to a sufficient depth to prevent further movement of coal tar into the river. The final wall configuration, including the need for hydraulic relief and associated treatment, will be determined during the design phase of this project.

4. Coal Tar Recovery:

A series of coal tar recovery wells will be constructed behind the barrier wall to collect coal tar that accumulates behind the wall. The number, depth, type and spacing of the recovery wells will be determined during the design phase of the remedy. Coal tar will be collected periodically from each well; however, if wells are determined by the Department to accumulate large quantities of coal tar over extended time periods, they can be converted to automated collection.

5. In-situ Solidification:

In the area where the natural gas pipeline enters the upland portion of the site, which precludes the safe construction of the barrier wall, focused solidification (ISS) of soil horizons containing coal tar will be performed to prevent migration of coal tar toward the river

ISS is a process that binds the soil particles in place creating a low permeability mass. The contaminated soil will be mixed in place together with solidifying agents (typically Portland cement) or other binding agents using an excavator or augers. The soil and binding agents are mixed to produce a solidified mass resulting in a low permeability monolith. The solidified mass will then be covered with a cover system as described in element 8 to prevent direct exposure to the solidified mass. The resulting solid matrix will reduce or eliminate mobility of contamination and also reduce or eliminate the matrix as a source of groundwater contamination.

6. Hudson River Dredging and Capping:

Dredging of coal tar contaminated sediments from the Hudson River channel where feasible, as described below. Contaminated dredge material will be dewatered and shipped off-site for proper treatment and disposal. A suitable benthic habitat will be established on the river bottom following dredging.

In areas near and above utility crossings, where dredging of contaminated sediment cannot be performed due to the possibility of damaging the utilities, coal tar contaminated sediment will be

capped in place to prevent the migration of tar into the water column and to provide a clean habitat for benthic organisms.

Similarly, along the steep river bank immediately adjacent to the site, where dredging would create significant safety concerns due to the potential for slope instability, contaminated sediments will be capped in place to prevent tar migration into the water column, and to provide a clean benthic habitat. Because of the steep slopes involved in this area, it is anticipated that this cap will be installed as overlapping panels, which will be anchored in place to prevent downslope slumping of the cap. Similar panels were successfully tested during the site investigation.

7. Cover System:

A site cover will be required to allow for industrial use of the site, except as noted below. The cover will consist either of the structures such as buildings, pavement, sidewalks comprising the site development or a soil cover in areas where the upper one foot of exposed surface soil will exceed the applicable soil cleanup objectives (SCOs). Where the soil cover is required it will be a minimum of one foot of soil placed over a demarcation layer. In the lower terrace area outside of the fenced regulator and transformer stations, the soil cover will meet commercial SCOs to allow for passive recreational use such as a riverfront walkway. Removal of shallow soil prior to the placement of the cover may be required in some areas in order to maintain the appropriate finished grade. Soil cover material, including any fill material brought to the site, will meet the SCOs for cover material as set forth in 6 NYCRR Part 375-6.7(d).

Where the soil cover is required over the ISS treatment area, it will consist of a minimum of four feet of soil, in order to protect the underlying ISS mass from repeated freeze/thaw action. The uppermost foot of this soil cover must meet the SCOs for commercial use, due to the potential for this area along the riverfront to be included in future passive recreational facilities such as a riverfront walkway. For areas where solidified material underlies the cover, no demarcation layer is required. The solidified material itself will serve as the demarcation layer due to the obviously different nature of the material.

7. River and Riverbank Restoration:

The existing riverbank, made up largely of rip rap stone and a collapsing concrete crib wall, will be extensively disturbed during remediation. Existing gas and electric infrastructure along the riverbank must be protected as the site is remediated and restored. The remedial design will include a riverbank restoration plan which will incorporate measures to maximize wildlife habitat while protecting energy infrastructure and allowing for future development of a public access walkway along the river bank. Natural stream bank techniques will be employed to the extent practicable. All remedial and restoration work will comply with the substantive requirements of ECL Article 15 and 6 NYCRR Part 608.

8. Institutional Controls:

Imposition of institutional controls in the form of environmental easements for the controlled

properties that:

- require the remedial party or site owner to complete and submit to the Department a periodic certification of institutional and engineering controls in accordance with Part 375-1.8(h)(3);
- allow the use and development of the controlled property for industrial use, except for areas where public access will be provided, which will be commercial use, as defined by Part 375-1.8(g), although land use is subject to local zoning laws;
- restrict the use of groundwater as a source of potable or process water, without necessary water quality treatment as determined by the NYSDOH or Dutchess County DOH; and
- require compliance with the Department approved Site Management Plan.

9. Site Management Plan

A Site Management Plan is required, which includes the following:

1. an Institutional and Engineering Control Plan that identifies all use restrictions and engineering controls for the site and details the steps and media-specific requirements necessary to ensure the following institutional and/or engineering controls remain in place and effective:

Institutional Controls:

The Environmental Easement discussed in Paragraph 8 above.

Engineering Controls:

- The cover system discussed in Paragraph 7 above;
- The solidified soils discussed in Paragraph 5 above;
- The sediment cap discussed in Paragraph 6 above; and
- The coal tar recovery system discussed in Paragraph 4 above.

This plan includes, but may not be limited to:

- o an Excavation Plan which details the provisions for management of future excavations in areas of remaining contamination;
- o descriptions of the provisions of the environmental easement including any land use, and groundwater use restrictions;
- o a provision for evaluation of the potential for soil vapor intrusion if the current building becomes occupied or if new buildings are developed on the site in the future, including provision for implementing actions recommended to address exposures related to soil vapor intrusion;
- o provisions for the management and inspection of the identified engineering controls;
- o maintaining site access controls and Department notification; and
- o the steps necessary for the periodic reviews and certification of the institutional and/or engineering controls.

2. a Monitoring Plan to assess the performance and effectiveness of the remedy. The plan includes, but may not be limited to:

- o monitoring of groundwater to assess the performance and effectiveness of the remedy;
- o a schedule of monitoring and frequency of submittals to the Department;

o monitoring for vapor intrusion for any occupied existing or future buildings developed on the site, as may be required by the Institutional and Engineering Control Plan discussed above.

3. an Operation and Maintenance (O&M) Plan to ensure continued operation, maintenance, optimization, monitoring, inspection, and reporting of any mechanical or physical components of the remedy. The plan includes, but is not limited to:

- o procedures for operating and maintaining the remedy;
- o compliance monitoring of treatment systems to ensure proper O&M as well as providing the data for any necessary permit or permit equivalent reporting;
- o maintaining site access controls and Department notification; and
- o providing the Department access to the site and O&M records.

Declaration

The remedy conforms with promulgated standards and criteria that are directly applicable, or that are relevant and appropriate and takes into consideration Department guidance, as appropriate. The remedy is protective of public health and the environment.

March 30, 2016
Date

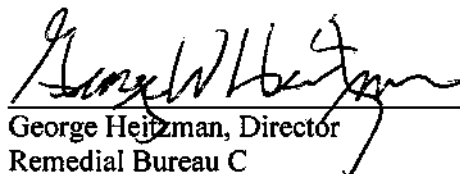
George Heitzman, Director
Remedial Bureau C

DECISION DOCUMENT

CH - Water St. - Poughkeepsie MGP
Poughkeepsie, Dutchess County
Site No. C314070
March 2016

SECTION 1: SUMMARY AND PURPOSE

The New York State Department of Environmental Conservation (the Department), in consultation with the New York State Department of Health (NYSDOH), has selected a remedy for the above referenced site. The disposal of contaminants at the site has resulted in threats to public health and the environment that would be addressed by the remedy. The disposal or release of contaminants at this site, as more fully described in this document, has contaminated various environmental media. Contaminants include hazardous waste and/or petroleum.

The New York State Brownfield Cleanup Program (BCP) is a voluntary program. The goal of the BCP is to enhance private-sector cleanups of brownfields and to reduce development pressure on "greenfields." A brownfield site is real property, the redevelopment or reuse of which may be complicated by the presence or potential presence of a contaminant.

The Department has issued this document in accordance with the requirements of New York State Environmental Conservation Law and 6 NYCRR Part 375. This document is a summary of the information that can be found in the site-related reports and documents.

SECTION 2: CITIZEN PARTICIPATION

The Department seeks input from the community on all remedies. A public comment period was held, during which the public was encouraged to submit comment on the proposed remedy. All comments on the remedy received during the comment period were considered by the Department in selecting a remedy for the site. Site-related reports and documents were made available for review by the public at the following document repository:

Adriance Memorial Library
93 Market Street
Poughkeepsie, NY 12601
Phone: (845) - 485 – 3445

Receive Site Citizen Participation Information By Email

Please note that the Department's Division of Environmental Remediation (DER) is "going paperless" relative to citizen participation information. The ultimate goal is to distribute citizen participation information about contaminated sites electronically by way of county email

listservs. Information will be distributed for all sites that are being investigated and cleaned up in a particular county under the State Superfund Program, Environmental Restoration Program, Brownfield Cleanup Program, Voluntary Cleanup Program, and Resource Conservation and Recovery Act Program. We encourage the public to sign up for one or more county listservs at <http://www.dec.ny.gov/chemical/61092.html>

SECTION 3: SITE DESCRIPTION AND HISTORY

Location:

The site is located on the eastern bank of the Hudson River at the end of Dutchess Avenue, in the north end of the City of Poughkeepsie. The site is approximately 13 acres in size and is bounded by: the Hudson River to the west, Dutchess Avenue to the north, North Water Street to the east and the Fallkill Creek to the south. An abandoned lumber treatment facility (AC Dutton Lumber), remediated under a Brownfield Cleanup Agreement and currently under redevelopment, forms the remainder of the northern site boundary. To the east, beyond Water Street, lies a Metro North railroad yard.

Site Features:

The upland portion of the site consists of two relatively flat terraces, separated by steep, rocky slopes with very thin soil cover. The lower terrace lies on the banks of the Hudson River, roughly 5-10 feet above sea level. The upper terrace is roughly 50 feet higher, bordering Water Street. The only structure located at the site is an unoccupied cinder block valve house associated with the gas regulator station.

Important energy infrastructure is located on the site. Gas and electric lines cross beneath the Hudson River at this location, and connect with gas and electrical lines which serve much wider areas surrounding Poughkeepsie. An electrical transformer station is located on the lower terrace at the southwestern portion of the site, where the electrical transmission line meets the shoreline and a natural gas regulator station occupies the northwestern corner of the lower terrace of the site where the gas transmission line meets the shoreline. The transformer station and regulator station are each enclosed within a fence.

Current Zoning and Land Use:

The site is zoned for industrial use. Surrounding land uses are predominantly, but not exclusively, industrial. Immediately north and south of the site, riverfront access provides for recreational use of the waterfront. Immediately across Dutchess Avenue to the north of the site, a large scale restricted residential redevelopment is underway. Two residences are situated directly across Dutchess Avenue at the northeast corner of the site.

The City of Poughkeepsie has supported efforts to construct a continuous pedestrian walkway along the river bank, and to connect this walkway with the Walkway Over the Hudson, which occupies a former railroad bridge that spans the site and the Hudson River. It is anticipated that the riverfront walkway may be extended to include riverfront portions of this MGP site at some point in the future.

Past Uses of the Site:

The site housed a large manufactured gas plant (MGP) from 1911 to the mid-1950s. Coal tar from the gas manufacturing process leaked from storage vessels and piping, and is still present in the subsurface. Some of these tars still discharge sporadically into the Hudson River.

Previous investigations at the site include: Phase 1 Investigation (1986), Phase 2 Investigation (1990), Supplemental RCRA Testing (1991), Supplemental Preliminary Site Assessment (2000), Supplemental Land Investigation (2003), Supplemental Land and River Investigations (2004), Supplemental River and Land Investigations (2005).

Site Geology and Hydrogeology:

The upper tier of the site consists of highly deformed slate and limestone bedrock, with a very thin fill cover. The lower tier consists of fill containing broken rock derived from the blasting of the cliff face and silty sand. Bedrock on the lower tier ranges from 0 to 15' below grade, deepening toward the river.

Groundwater levels on the upper tier range from 10 to 19 feet below ground surface (bgs) and from 0 to 14 feet bgs on the lower tier. Flow in both the overburden and bedrock aquifers is to the west, toward the river. The Hudson River in this area is a tidal stream and tidal influences to near shore groundwater levels on the lower tier is pronounced.

A site location map is attached as Figure 1.

SECTION 4: LAND USE AND PHYSICAL SETTING

The Department may consider the current, intended, and reasonably anticipated future land use of the site and its surroundings when evaluating a remedy for soil remediation. For this site, alternatives (or an alternative) that restrict(s) the use of the site to industrial use as described in Part 375-1.8(g) were/was evaluated in addition to an alternative which would allow for unrestricted use of the site.

A comparison of the results of the Remedial Investigation (RI) to the appropriate standards, criteria and guidance values (SCGs) for the identified land use and the unrestricted use SCGs for the site contaminants is available in the RI Report.

SECTION 5: ENFORCEMENT STATUS

The Applicant under the Brownfield Cleanup Agreement is a Participant. The Applicant has an obligation to address on-site and off-site contamination. Accordingly, no enforcement actions are necessary.

SECTION 6: SITE CONTAMINATION

6.1: Summary of the Remedial Investigation

A remedial investigation (RI) serves as the mechanism for collecting data to:

- characterize site conditions;
- determine the nature of the contamination; and
- assess risk to human health and the environment.

The RI is intended to identify the nature (or type) of contamination which may be present at a site and the extent of that contamination in the environment on the site, or leaving the site. The RI reports on data gathered to determine if the soil, groundwater, soil vapor, indoor air, surface water or sediments may have been contaminated. Monitoring wells are installed to assess groundwater and soil borings or test pits are installed to sample soil and/or waste(s) identified. If other natural resources are present, such as surface water bodies or wetlands, the water and sediment may be sampled as well. Based on the presence of contaminants in soil and groundwater, soil vapor will also be sampled for the presence of contamination. Data collected in the RI influence the development of remedial alternatives. The RI report is available for review in the site document repository and the results are summarized in section 6.3.

The analytical data collected on this site includes data for:

- groundwater
- surface water
- soil
- sediment
- soil vapor

6.1.1: Standards, Criteria, and Guidance (SCGs)

The remedy must conform to promulgated standards and criteria that are directly applicable or that are relevant and appropriate. The selection of a remedy must also take into consideration guidance, as appropriate. Standards, Criteria and Guidance are hereafter called SCGs.

To determine whether the contaminants identified in various media are present at levels of concern, the data from the RI were compared to media-specific SCGs. The Department has developed SCGs for groundwater, surface water, sediments, and soil. The NYSDOH has developed SCGs for drinking water and soil vapor intrusion. For a full listing of all SCGs see: <http://www.dec.ny.gov/regulations/61794.html>

6.1.2: RI Results

The data have identified contaminants of concern. A "contaminant of concern" is a contaminant that is sufficiently present in frequency and concentration in the environment to require evaluation for remedial action. Not all contaminants identified on the property are contaminants of concern. The nature and extent of contamination and environmental media requiring action are summarized below. Additionally, the RI Report contains a full discussion of the data. The contaminant(s) of concern identified at this site is/are:

coal tar

benzene, toluene, ethylbenzene and
xylenes (BTEX)

polycyclic aromatic hydrocarbons (PAHS),
total

The contaminant(s) of concern exceed the applicable SCGs for:

- groundwater
- soil
- sediment

6.2: Interim Remedial Measures

An interim remedial measure (IRM) is conducted at a site when a source of contamination or exposure pathway can be effectively addressed before issuance of the Decision Document.

The following IRM(s) has/have been completed at this site based on conditions observed during the RI.

Shallow soil removal for construction of elevator to the Walkway Over the Hudson

A soil removal IRM was conducted in 2012 by Central Hudson Gas and Electric, to allow for construction of an elevator to the Walkway Over the Hudson (WOTH) New York State Park and a pedestrian walkway to reach the elevator.

The IRM for the elevator to the WOTH included the removal and off-site disposal of the uppermost 2 feet of soil located on the southern portion of the site adjacent to a proposed new walking pathway and elevator. Clean soil meeting restricted residential SCOs was then placed above a demarcation layer as backfill in the excavated area. The walking pathway and elevator associated with the WOTH, were constructed by others and were not part of the IRM. They are separated from the rest of the site by a fence.

6.3: Summary of Environmental Assessment

This section summarizes the assessment of existing and potential future environmental impacts presented by the site. Environmental impacts may include existing and potential future exposure pathways to fish and wildlife receptors, wetlands, groundwater resources, and surface water. The RI report presents a detailed discussion of any existing and potential impacts from the site to fish and wildlife receptors.

Contaminants of Concern:

The principal waste disposed on the site was MGP tar, which is a brown, oily liquid that is slightly denser than water. Large amounts of this tar escaped into the subsurface from plant structures located on the lower terrace near the river bank. This tar can still be found in soils and bedrock beneath the site. Tar was also discharged directly to the Hudson River, where it is found in sediments on the river bottom.

The tar contains high levels of benzene, toluene, ethylbenzene and xylenes, collectively known as BTEX, and polycyclic aromatic hydrocarbon (PAH) compounds. Both groups of compounds have been found in site groundwater.

Impacted Media:

The soil and bedrock aquifers beneath the western portion of the site, along the banks of the Hudson River, are contaminated with separate phase MGP tar and with dissolved BTEX and PAH compounds derived from the tar. MGP tar is being collected on a bi-annual basis from two wells along the western boundary of the site. Over 500 gallons have been collected from one overburden well along the riverfront. Hudson River sediments contain MGP tar and PAH contamination derived from the tar.

Subsurface Soil and Bedrock:

On the upper tier of the site, tar was observed in bedrock fractures in 3 of 32 soil borings. On the lower tier of the site, tar was observed in subsurface soil in 54 of 68 sample locations. BTEX was detected in 15 of the 20 samples analyzed. PAH constituents were detected in 19 of 20 samples. Total BTEX concentrations ranged from 0.001 to 916 parts per million (ppm) and total PAH concentrations ranged from 0.17 ppm to 16,300 ppm. Twelve of the 20 samples analyzed contained concentrations of the following individual constituents above the industrial use SCOs: benzene, benzo(a)anthracene, benzo(a)pyrene, benzo(b)fluoranthene, benzo(k)fluoranthene, chrysene, naphthalene, phenanthrene, and pyrene.

Six subsurface soil samples were collected and analyzed for target analyte list (TAL) metals. One or more metals were detected at each location. Arsenic was detected at concentrations exceeding industrial use SCOs at one location that is co-located with visible non-aqueous phase liquid (NAPL) and industrial use SCO exceedances for PAHs.

Surface Soil:

Twenty-two surface soil samples were collected and analyzed for BTEX and PAHs. BTEX constituents were detected in 7 of the 22 samples with total BTEX concentrations ranging from 0.00061 ppm to 151 ppm. No samples exhibited concentrations of individual BTEX constituents above industrial use SCOs. PAH constituents were detected in 21 of the 22 samples, with detected total PAH concentrations ranging from 0.55 ppm to 5,200 ppm. Thirteen of the twenty-two samples exhibited concentrations of one or more of the following individual PAH constituents exceeding industrial use SCOs: benzo(a)anthracene, benzo(a)pyrene, benzo(b)fluoranthene, dibenzo(a,h)anthracene, indeno(1,2,3,c-d)pyrene, naphthalene.

Twenty surface soil samples were analyzed for TAL metals. Measurable concentrations of metals were detected in 14 of the 20 samples. None of the concentrations exceeded industrial use SCOs.

Groundwater:

In three overburden wells sampled, BTEX concentrations ranged from non-detect to 9,744 parts per billion (ppb) and total PAH concentrations ranged from non-detect to 691 ppb. Trace thicknesses of NAPL were observed in all three overburden wells. In four bedrock wells sampled, total BTEX concentrations ranged from non-detect to 138 ppb and total PAH

concentrations ranged from non-detect to 462 ppb. In three bedrock wells sampled for TAL metals, cadmium was detected at concentrations ranging from 5 to 8 ppb and cyanide was detected at concentrations ranging from 80 to 460 ppb. Trace thicknesses of NAPL were observed in three of the four bedrock wells sampled.

Groundwater samples exceeded Ambient Water Quality Standards for the following individual constituents: benzene, ethylbenzene, m/p-Xylene, o-Xylene and toluene; acenaphthene, benzo(a)anthracene, benzo(a)pyrene, benzo(b)fluoranthene, benzo(k)fluoranthene, chrysene, fluorene, indeno(1,2,3-cd)pyrene, naphthalene, phenanthrene, pyrene, cadmium and cyanide.

Sediment:

Tar impacted sediments extend approximately 300 feet from the shoreline, and from approximately 350 feet north of the gas transmission line to approximately 350 feet south of the electrical transmission line. BTEX was observed in each of the nine sediment samples analyzed for volatile organic compounds (VOCs), with total BTEX concentrations ranging from 0.0091 ppm to 1,310 ppm. PAHs were detected in 239 of 249 samples analyzed for semi-volatile organic compounds (SVOCs), with concentrations ranging from non-detect to 21,200 ppm. 207 of the 239 samples collected for SVOC analysis exceeded the Class A sediment screening value of 4 ppm total PAH.

Surface Water:

Three surface water samples were collected from the Hudson River for analysis. Although none of the analytical results exceeded ambient water quality standards, the gas ebullition within tar-impacted river sediments routinely results in sheens and slicks on the river surface near the site.

Soil Vapor:

Two of the twenty four soil vapor samples collected on the site exhibited detectable levels of benzene ranging from 32 ug/m³ to 64 ug/m³ respectively .

Special Resources impacted.

The Hudson River is impacted by coal tar in the area near the MGP site, with both sediments and the overlying water column affected. Tar continues to move into the Hudson River by subsurface migration from upland source areas, but the principal impact of tar to the water column is the result of releases of tar from the tar contaminated on the river bottom which causes frequent slicks and sheens on the water surface, primarily during the warm weather months.

The site is within the Kingston-Poughkeepsie Deepwater Significant Coastal Fish and Wildlife Habitat area, a stretch of the Hudson River that is ecologically important to the life history of two endangered species, the Atlantic and Shortnose Sturgeon

6.4: Summary of Human Exposure Pathways

This human exposure assessment identifies ways in which people may be exposed to site-related contaminants. Chemicals can enter the body through three major pathways (breathing, touching or swallowing). This is referred to as *exposure*.

Access to the site is restricted and measures are in place to control the potential for coming in contact with subsurface soil and groundwater contamination remaining on the site. Contaminated groundwater at the site is not used for drinking or other purposes, and the site is served by a public water supply that obtains water from a different source not affected by this contamination. Volatile organic compounds in the soil or groundwater may move into the soil vapor (air spaces within the soil), which in turn may move into overlying buildings and affect the indoor air quality. This process, which is similar to movement of radon gas from the subsurface into the indoor air of buildings, is referred to as soil vapor intrusion. Because there are no occupied buildings on the site, the inhalation of site-related contaminants due to soil vapor intrusion does not represent a current concern. People using the Hudson River for recreational purposes such as boating may come into contact with site-related contaminants associated with sheens present on the water's surface.

6.5: Summary of the Remediation Objectives

The objectives for the remedial program have been established through the remedy selection process stated in 6 NYCRR Part 375. The goal for the remedial program is to restore the site to pre-disposal conditions to the extent feasible. At a minimum, the remedy shall eliminate or mitigate all significant threats to public health and the environment presented by the contamination identified at the site through the proper application of scientific and engineering principles.

The remedial action objectives for this site are:

Groundwater

RAOs for Public Health Protection

- Prevent ingestion of groundwater with contaminant levels exceeding drinking water standards.
- Prevent contact with, or inhalation of volatiles, from contaminated groundwater.

RAOs for Environmental Protection

- Restore ground water aquifer to pre-disposal/pre-release conditions, to the extent practicable.
- Prevent the discharge of contaminants to surface water.
- Remove the source of ground or surface water contamination.

Soil

RAOs for Public Health Protection

- Prevent ingestion/direct contact with contaminated soil.

RAOs for Environmental Protection

- Prevent migration of contaminants that would result in groundwater or surface water contamination.
- Prevent impacts to biota from ingestion/direct contact with soil causing toxicity or impacts from bioaccumulation through the terrestrial food chain.

Surface Water

RAOs for Public Health Protection

- Prevent contact or inhalation of contaminants from impacted water bodies.
- Prevent surface water contamination which may result in fish advisories.

RAOs for Environmental Protection

- Prevent impacts to biota from ingestion/direct contact with surface water causing toxicity and impacts from bioaccumulation through the marine or aquatic food chain.

Sediment

RAOs for Public Health Protection

- Prevent direct contact with contaminated sediments.
- Prevent surface water contamination which may result in fish advisories.

RAOs for Environmental Protection

- Prevent releases of contaminant(s) from sediments that would result in surface water levels in excess of (ambient water quality criteria).
- Prevent impacts to biota from ingestion/direct contact with sediments causing toxicity or impacts from bioaccumulation through the marine or aquatic food chain.
- Restore sediments to pre-release/background conditions to the extent feasible.

Soil Vapor

RAOs for Public Health Protection

- Mitigate impacts to public health resulting from existing, or the potential for, soil vapor intrusion into buildings at a site.

SECTION 7: ELEMENTS OF THE SELECTED REMEDY

The alternatives developed for the site and the evaluation of the remedial criteria are presented in the Alternative Analysis. The remedy is selected pursuant to the remedy selection criteria set forth in DER-10, Technical Guidance for Site Investigation and Remediation and 6 NYCRR Part 375.

The selected remedy is a Track 2: Restricted use with generic soil cleanup objectives remedy.

The selected remedy is referred to as the Source Excavation, Barrier Wall with Tar Collection, and Sediment Removal with L remedy.

The elements of the selected remedy, as shown in Figure 2, are as follows:

1. A remedial design program will be implemented to provide the details necessary for the construction, operation, optimization, maintenance, and monitoring of the remedial program. Green remediation principles and techniques will be implemented to the extent feasible in the design, implementation, and site management of the remedy as per DER-31. The major green remediation components are as follows;

- Considering the environmental impacts of treatment technologies and remedy stewardship over the long term;
- Reducing direct and indirect greenhouse gases and other emissions;

- Increasing energy efficiency and minimizing use of non-renewable energy;
- Conserving and efficiently managing resources and materials;
- Reducing waste, increasing recycling and increasing reuse of materials which would otherwise be considered a waste;
- Maximizing habitat value and creating habitat when possible;
- Fostering green and healthy communities and working landscapes which balance ecological, economic and social goals; and
- Integrating the remedy with the end use where possible and encouraging green and sustainable re-development.

2. Excavation and off-site disposal of upland contaminant source areas, located in the northern portion of the lower terrace area, to include:

- grossly contaminated soil, as defined in 6 NYCRR Part 375-1.2(u);
- removal of all underground MGP structures and underground piping; and
- soil containing visual coal tar or non-aqueous phase liquid;

3. Barrier Wall:

A subsurface barrier wall will be installed along the east bank of the Hudson River to prevent the migration of coal tar to the river. The wall will be constructed along the eastern bank of the river from the gas utility crossing immediately south of Dutchess Ave to a point approximately 450 feet to the south, where the walkway over the Hudson extends above the site. The wall will extend to a sufficient depth to prevent further movement of coal tar into the river. The final wall configuration, including the need for hydraulic relief and associated treatment, will be determined during the design phase of this project.

4. Coal Tar Recovery:

A series of coal tar recovery wells will be constructed behind the barrier wall to collect coal tar that accumulates behind the wall. The number, depth, type and spacing of the recovery wells will be determined during the design phase of the remedy. Coal tar will be collected periodically from each well; however, if wells are determined by the Department to accumulate large quantities of coal tar over extended time periods, they can be converted to automated collection.

5. In-situ Solidification:

In the area where the natural gas pipeline enters the upland portion of the site, which precludes the safe construction of the barrier wall, focused solidification (ISS) of soil horizons containing coal tar will be performed to prevent migration of coal tar toward the river

ISS is a process that binds the soil particles in place creating a low permeability mass. The contaminated soil will be mixed in place together with solidifying agents (typically Portland cement) or other binding agents using an excavator or augers. The soil and binding agents are mixed to produce a solidified mass resulting in a low permeability monolith. The solidified mass

will then be covered with a cover system as described in element 8 to prevent direct exposure to the solidified mass. The resulting solid matrix will reduce or eliminate mobility of contamination and also reduce or eliminate the matrix as a source of groundwater contamination.

6. Hudson River Dredging and Capping:

Dredging of coal tar contaminated sediments from the Hudson River channel where feasible, as described below. Contaminated dredge material will be dewatered and shipped off-site for proper treatment and disposal. A suitable benthic habitat will be established on the river bottom following dredging.

In areas near and above utility crossings, where dredging of contaminated sediment cannot be performed due to the possibility of damaging the utilities, coal tar contaminated sediment will be capped in place to prevent the migration of tar into the water column and to provide a clean habitat for benthic organisms.

Similarly, along the steep river bank immediately adjacent to the site, where dredging would create significant safety concerns due to the potential for slope instability, contaminated sediments will be capped in place to prevent tar migration into the water column, and to provide a clean benthic habitat. Because of the steep slopes involved in this area, it is anticipated that this cap will be installed as overlapping panels, which will be anchored in place to prevent downslope slumping of the cap. Similar panels were successfully tested during the site investigation.

7. Cover System:

A site cover will be required to allow for industrial use of the site, except as noted below. The cover will consist either of the structures such as buildings, pavement, sidewalks comprising the site development or a soil cover in areas where the upper one foot of exposed surface soil will exceed the applicable soil cleanup objectives (SCOs). Where the soil cover is required it will be a minimum of one foot of soil placed over a demarcation layer. In the lower terrace area outside of the fenced regulator and transformer stations, the soil cover will meet commercial SCOs to allow for passive recreational use such as a riverfront walkway. Removal of shallow soil prior to the placement of the cover may be required in some areas in order to maintain the appropriate finished grade. Soil cover material, including any fill material brought to the site, will meet the SCOs for cover material as set forth in 6 NYCRR Part 375-6.7(d).

Where the soil cover is required over the ISS treatment area, it will consist of a minimum of four feet of soil, in order to protect the underlying ISS mass from repeated freeze/thaw action. The uppermost foot of this soil cover must meet the SCOs for commercial use, due to the potential for this area along the riverfront to be included in future passive recreational facilities such as a riverfront walkway. For areas where solidified material underlies the cover, no demarcation layer is required. The solidified material itself will serve as the demarcation layer due to the obviously different nature of the material.

7. River and Riverbank Restoration:

The existing riverbank, made up largely of rip rap stone and a collapsing concrete crib wall, will be extensively disturbed during remediation. Existing gas and electric infrastructure along the riverbank must be protected as the site is remediated and restored. The remedial design will include a riverbank restoration plan which will incorporate measures to maximize wildlife habitat while protecting energy infrastructure and allowing for future development of a public access walkway along the river bank. Natural stream bank techniques will be employed to the extent practicable. All remedial and restoration work will comply with the substantive requirements of ECL Article 15 and 6 NYCRR Part 608.

8. Institutional Controls:

Imposition of institutional controls in the form of environmental easements for the controlled properties that:

- require the remedial party or site owner to complete and submit to the Department a periodic certification of institutional and engineering controls in accordance with Part 375-1.8(h)(3);
- allow the use and development of the controlled property for industrial use, except for areas where public access will be provided, which will be commercial use, as defined by Part 375-1.8(g), although land use is subject to local zoning laws;
- restrict the use of groundwater as a source of potable or process water, without necessary water quality treatment as determined by the NYSDOH or Dutchess County DOH; and
- require compliance with the Department approved Site Management Plan.

9. Site Management Plan

A Site Management Plan is required, which includes the following:

1. an Institutional and Engineering Control Plan that identifies all use restrictions and engineering controls for the site and details the steps and media-specific requirements necessary to ensure the following institutional and/or engineering controls remain in place and effective:

Institutional Controls:

The Environmental Easement discussed in Paragraph 8 above.

Engineering Controls:

- The cover system discussed in Paragraph 7 above;
- The solidified soils discussed in Paragraph 5 above;
- The sediment cap discussed in Paragraph 6 above; and
- The coal tar recovery system discussed in Paragraph 4 above.

This plan includes, but may not be limited to:

- o an Excavation Plan which details the provisions for management of future excavations in areas of remaining contamination;







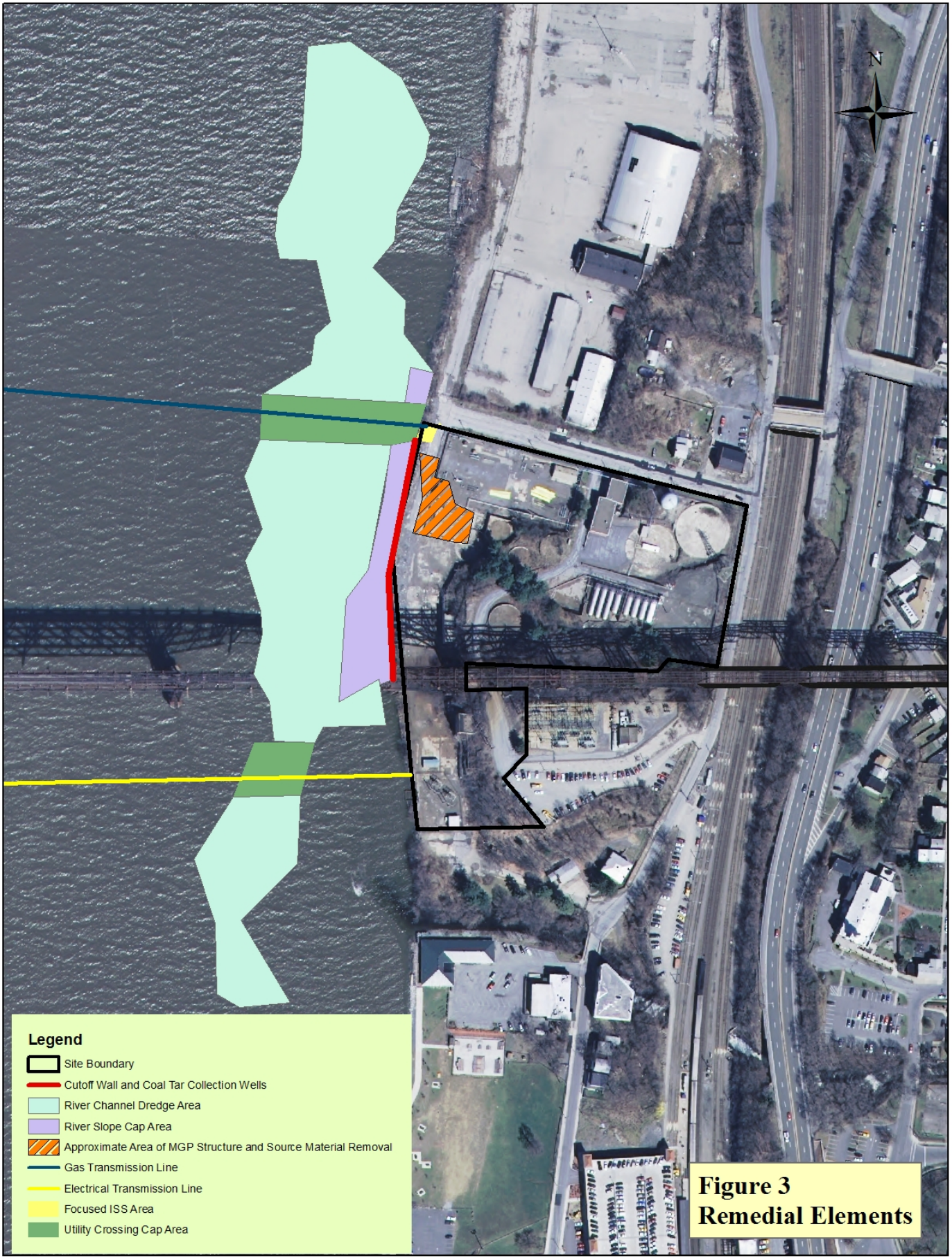

- o descriptions of the provisions of the environmental easement including any land use, and groundwater use restrictions;
 - o a provision for evaluation of the potential for soil vapor intrusion if the current building becomes occupied or if new buildings are developed on the site in the future, including provision for implementing actions recommended to address exposures related to soil vapor intrusion;
 - o provisions for the management and inspection of the identified engineering controls;
 - o maintaining site access controls and Department notification; and
 - o the steps necessary for the periodic reviews and certification of the institutional and/or engineering controls.
2. a Monitoring Plan to assess the performance and effectiveness of the remedy. The plan includes, but may not be limited to:
- o monitoring of groundwater to assess the performance and effectiveness of the remedy;
 - o a schedule of monitoring and frequency of submittals to the Department;
 - o monitoring for vapor intrusion for any occupied existing or future buildings developed on the site, as may be required by the Institutional and Engineering Control Plan discussed above.
3. an Operation and Maintenance (O&M) Plan to ensure continued operation, maintenance, optimization, monitoring, inspection, and reporting of any mechanical or physical components of the remedy. The plan includes, but is not limited to:
- o procedures for operating and maintaining the remedy;
 - o compliance monitoring of treatment systems to ensure proper O&M as well as providing the data for any necessary permit or permit equivalent reporting;
 - o maintaining site access controls and Department notification; and
 - o providing the Department access to the site and O&M records.



Figure 2:
Site Features



Legend

-  Site Boundary
-  Cutoff Wall and Coal Tar Collection Wells
-  River Channel Dredge Area
-  River Slope Cap Area
-  Approximate Area of MGP Structure and Source Material Removal
-  Gas Transmission Line
-  Electrical Transmission Line
-  Focused ISS Area
-  Utility Crossing Cap Area

**Figure 3
Remedial Elements**

Attachment 4
Site Photographs

Facility Name: Former Poughkeepsie MGP Facility	Site Location: 2 Dutchess Avenue, Poughkeepsie, New York	Project No.: 60540671
---	--	---------------------------------

Photo No. 1	Date: 6/21/17
Direction Photo Taken: Southeast	
Description: View from the Hudson River across the proposed dredging area, with the former MGP site in the background, north (left) of the Walkway Over the Hudson bridge.	



Photo No. 2	Date: 6/21/17
Direction Photo Taken: East	
Description: Typical shoreline view within the project area, showing timber bulkhead in foreground and deteriorated cribbing along the site shoreline; the river slope regrading and capping will occur across this area.	



Facility Name: Former Poughkeepsie MGP Facility	Site Location: 2 Dutchess Avenue, Poughkeepsie, New York	Project No.: 60540671
---	--	---------------------------------

Photo No.: 3	Date: 10/6/16	
Direction Photo Taken: North		
Description: View north along site shoreline; river slope regrading and capping will occur immediately along the shoreline, and dredging and backfill work will take place approximately 100 feet offshore in the mid-ground.		

Photo No.: 4	Date: 6/14/17	
Direction Photo Taken: South		
Description: View south along site shoreline; timber bulkhead and deteriorated cribbing; river slope regrading and capping will occur immediately along the shoreline, and dredging and backfill work will take place approximately 100 feet offshore in the mid-ground.		

Facility Name: Former Poughkeepsie MGP Facility	Site Location: 2 Dutchess Avenue, Poughkeepsie, New York	Project No.: 60540671
---	--	---------------------------------

Photo No. 5	Date: 10/6/16
Direction Photo Taken: South	
Description: View south from the southern edge of the former MGP site; dredging will occur in discontinuous areas approximately 100 feet off the shoreline up to 500 feet southward.	



Photo No. 6	Date: 11/10/17
Direction Photo Taken: North	
Description: View north from south of the site; dredging will occur in discontinuous areas approximately 100 feet off the shoreline up to 1,000 feet northward..	



Facility Name: Former Poughkeepsie MGP Facility	Site Location: 2 Dutchess Avenue, Poughkeepsie, New York	Project No.: 60540671
---	--	---------------------------------

Photo No. 7	Date: 10/6/16
Direction Photo Taken: Down, North	
Description: View looking north along the shoreline from the Walkway Over the Hudson, showing the area along which river slope regrading and capping will occur.	

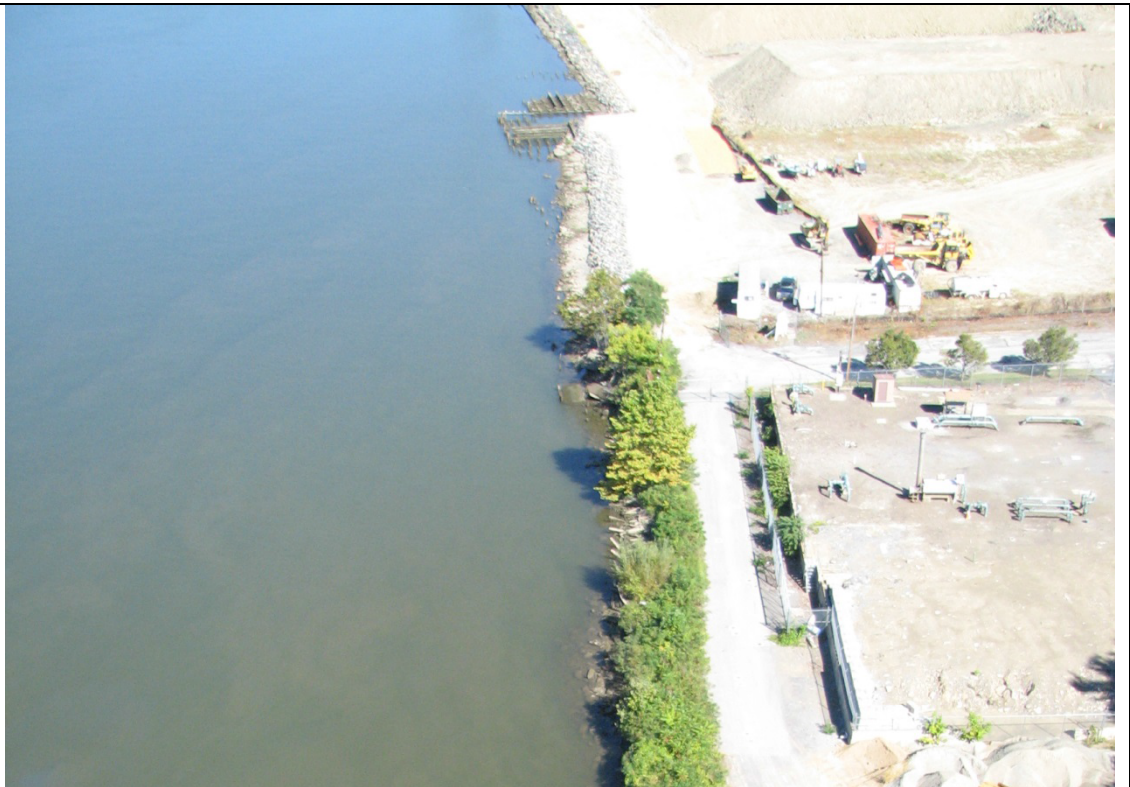

Photo No. 8	Date: 10/6/16
Direction Photo Taken: Down, Northeast	
Description: View looking east at the shoreline from the Walkway Over the Hudson; river slope regrading and capping will occur adjacent to the shoreline, and dredging will occur in the foreground.	



Facility Name: Former Poughkeepsie MGP Facility	Site Location: 2 Dutchess Avenue, Poughkeepsie, New York	Project No.: 60540671
---	--	---------------------------------

Photo No. 9	Date: 10/6/16
Direction Photo Taken: North	
Description: View looking north along the shoreline from the Walkway Over the Hudson; river slope regrading and capping will occur along the shoreline in the foreground from Dutchess Avenue (midground) southward, and dredging will occur approximately 100 feet off the shoreline to a distance of approximately 500 feet north of Dutchess Avenue.	



Photo No. 10	Date: 10/6/16
Direction Photo Taken: East	
Description: View looking east at the shoreline from the Walkway Over the Hudson; river slope regrading and capping will occur adjacent to the shoreline, and dredging will occur in the foreground from about 100 to 400 feet off the shoreline (foreground).	



Facility Name: Former Poughkeepsie MGP Facility	Site Location: 2 Dutchess Avenue, Poughkeepsie, New York	Project No.: 60540671
---	--	---------------------------------

Photo No. 11	Date: 11/29/17	
Direction Photo Taken: Panoramic West		
Description: View looking west of the site shoreline from the site; river slope regrading and capping will occur along the shoreline in the foreground from Dutchess Avenue (right) southward, and dredging will occur approximately 100 feet off the shoreline to a distance of approximately 500 feet north (background).		

Photo No. 12	Date: 60/14/17	
Direction Photo Taken: Panoramic East		
Description: View east along site shoreline; river slope regrading and capping will occur immediately along the shoreline, and dredging and backfill work will take place approximately 100 feet offshore.		

Attachment 5

**Federal Consistency Assessment Form, Coastal Zone
Consistency Policy Determination and HIT Analysis**

NEW YORK STATE DEPARTMENT OF STATE
COASTAL MANAGEMENT PROGRAM

Federal Consistency Assessment Form

An applicant, seeking a permit, license, waiver, certification or similar type of approval from a federal agency which is subject to the New York State Coastal Management Program (CMP), shall complete this assessment form for any proposed activity that will occur within and/or directly affect the State's Coastal Area. This form is intended to assist an applicant in certifying that the proposed activity is consistent with New York State's CMP as required by U.S. Department of Commerce regulations (15 CFR 930.57). It should be completed at the time when the federal application is prepared. The Department of State will use the completed form and accompanying information in its review of the applicant's certification of consistency.

A. **APPLICANT** (please print)

1. Name: _____
2. Address: _____
3. Telephone: Area Code () _____

B. **PROPOSED ACTIVITY:**

1. Brief description of activity:

2. Purpose of activity:

3. Location of activity:

County	City, Town, or Village	Street or Site Description
--------	------------------------	----------------------------

4. Type of federal permit/license required: _____

5. Federal application number, if known: _____

6. If a state permit/license was issued or is required for the proposed activity, identify the state agency and provide the application or permit number, if known:

C. **COASTAL ASSESSMENT** Check either "YES" or "NO" for each of these questions. The numbers following each question refer to the policies described in the CMP document (see footnote on page 2) which may be affected by the proposed activity.

- | | |
|--|--------|
| 1. Will the proposed activity result in any of the following: | YES/NO |
| a. Large physical change to a site within the coastal area which will require the preparation of an environmental impact statement? (11, 22, 25, 32, 37, 38, 41, 43) | — — |
| b. Physical alteration of more than two acres of land along the shoreline, land under water or coastal waters? (2, 11, 12, 20, 28, 35, 44) | — — |
| c. Revitalization/redevelopment of a deteriorated or underutilized waterfront site? (1) | — |
| d. Reduction of existing or potential public access to or along coastal waters? (19, 20) | — |
| e. Adverse effect upon the commercial or recreational use of coastal fish resources? (9,10) | — |
| f. Siting of a facility essential to the exploration, development and production of energy resources in coastal waters or on the Outer Continental Shelf? (29) | — — |
| g. Siting of a facility essential to the generation or transmission of energy? (27) | — |
| h. Mining, excavation, or dredging activities, or the placement of dredged or fill material in coastal waters? (15, 35) | — — |
| i. Discharge of toxics, hazardous substances or other pollutants into coastal waters? (8, 15, 35) | — — |
| j. Draining of stormwater runoff or sewer overflows into coastal waters? (33) | — |
| k. Transport, storage, treatment, or disposal of solid wastes or hazardous materials? (36, 39) | — — |
| l. Adverse effect upon land or water uses within the State's small harbors? (4) | — — |
| 2. Will the proposed activity affect or be located in, on, or adjacent to any of the following: | YES/NO |
| a. State designated freshwater or tidal wetland? (44) | — — |
| b. Federally designated flood and/or state designated erosion hazard area? (11, 12, 17) | — — |
| c. State designated significant fish and/or wildlife habitat? (7) | — |
| d. State designated significant scenic resource or area? (24) | — |
| e. State designated important agricultural lands? (26) | — — |
| f. Beach, dune or Barrier Island? (12) | — — |
| g. Major ports of Albany, Buffalo, Ogdensburg, Oswego or New York? (3) | — — |
| h. State, county, or local park? (19, 20) | — — |
| i. Historic resource listed on the National or State Register of Historic Places? (23) | — — |
| 3. Will the proposed activity require any of the following: | YES/NO |
| a. Waterfront site? (2, 21, 22) | — |
| b. Provision of new public services or infrastructure in undeveloped or sparsely populated sections of the coastal area? (5) | — — |
| c. Construction or reconstruction of a flood or erosion control structure? (13, 14, 16) | — — |
| d. State water quality permit or certification? (30, 38, 40) | — — |
| e. State air quality permit or certification? (41, 43) | — — |
| 4. Will the proposed activity occur within and/or affect an area covered by a State-approved local waterfront revitalization program, or State-approved regional coastal management program? (see policies in program document*) | — — |

D. ADDITIONAL STEPS

1. If all of the questions in Section C are answered "NO", then the applicant or agency shall complete Section E and submit the documentation required by Section F.
2. If any of the questions in Section C are answered "YES", then the applicant or agent is advised to consult the CMP, or where appropriate, the local waterfront revitalization program document*. The proposed activity must be analyzed in more detail with respect to the applicable state or local coastal policies. On a separate page(s), the applicant or agent shall: (a) identify, by their policy numbers, which coastal policies are affected by the activity, (b) briefly assess the effects of the activity upon the policy; and, (c) state how the activity is consistent with each policy. Following the completion of this written assessment, the applicant or agency shall complete Section E and submit the documentation required by Section F.

E. CERTIFICATION

The applicant or agent must certify that the proposed activity is consistent with the State's CMP or the approved local waterfront revitalization program, as appropriate. If this certification cannot be made, the proposed activity shall not be undertaken. If this certification can be made, complete this Section.

"The proposed activity complies with New York State's approved Coastal Management Program, or with the applicable approved local waterfront revitalization program, and will be conducted in a manner consistent with such program."

Applicant/Agent's Name: _____

Address: _____

Telephone: Area Code (**718**) _____

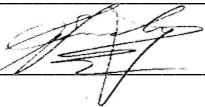
Applicant/Agent's Signature:  _____ Date: _____

F. SUBMISSION REQUIREMENTS

1. The applicant or agent shall submit the following documents to the **New York State Department of State, Office of Planning and Development, Attn: Consistency Review Unit, One Commerce Plaza-Suite 1010, 99 Washington Avenue, Albany, New York 12231.**

- a. Copy of original signed form.
- b. Copy of the completed federal agency application.
- c. Other available information which would support the certification of consistency.

2. The applicant or agent shall also submit a copy of this completed form along with his/her application to the federal agency.

3. If there are any questions regarding the submission of this form, contact the Department of State at (518) 474-6000.

*These state and local documents are available for inspection at the offices of many federal agencies, Department of environmental Conservation and Department of State regional offices, and the appropriate regional and county planning agencies. Local program documents are also available for inspection at the offices of the appropriate local government.

Analysis of Coastal Policies

Central Hudson Gas & Electric Corporation | Former North Water Street Manufactured Gas Plant Site

Analysis of Coastal Policies - Federal Consistency Assessment Form

The following narrative identifies which of the Coastal Management Policies (CMP) policies will be potentially affected by the proposed project, assesses the potential effects of the proposed work upon each policy, and states how the activity is consistent with each policy. As required by Sections C and D of the Federal Consistency Assessment Form, CMP policies that may be affected by the proposed project are expanded upon below. Policies not directly relevant to the proposed work have been omitted from this discussion.

POLICY 2: Facilitate the siting of water dependent uses and facilities on or adjacent to coastal waters

The proposed activities are consistent with this policy. As the proposed work consists of dredging of impacted sediment from within the Hudson River and associated cover placement, this project is water-dependent and the proposed activities can only be conducted in this water body. Given the nature of this project, there is only one (water-dependent) siting option for where work may be conducted.

POLICY 7: Significant coastal fish and wildlife habitats will be protected, preserved, and where practical, restored so as to maintain their viability as habitats

The proposed activities are consistent with this policy. In the Hudson River adjacent to the project site is the Kingston – Poughkeepsie Deepwater Significant Coastal Fish and Wildlife Habitat area (SCFWH). Dredging of the contaminated sediment is proposed to be conducted within a permitted period of time stipulated by the New York State Department of Environmental Conservation (NYSDEC) (yet to be determined) in 2018 and 2019 if necessary. Dredging in the SCFWH area of approximately 25,000 cubic yards (within approximately 4 acres) will be conducted using an environmental bucket within a containment cell which will be outfitted with turbidity curtains that extend to the river bottom and floating booms on all sides to control turbidity beyond the dredging area.

A Habitat Impairment Test (HIT) was prepared for this project (see attached). The HIT identifies that the impacts would be minimal and that the removal of potentially contaminated sediments would have long-term positive effects for the SCFWH.

Best Management Practices (BMPs) and engineering controls will be implemented prior to the start of the dredging and will remain in place throughout the remediation. Additionally, dredged areas will be backfilled with clean sand imported from upland sources and transported to the site via barge. The clean sand will be placed using specially fabricated conveyors to help restore the bottom contours to pre-dredging conditions. Due to these measures and the temporary nature of the project, it is not anticipated that the proposed project will have a long-term adverse effect upon the habitat. Implementation of the proposed dredging will assist in

improving the water quality, sediment quality, and habitat of the SCFWH area and the Hudson River.

POLICY 11: Buildings and other structures will be sited in the coastal area so as to minimize damage to property and the endangering of human lives caused by flooding and erosion

The proposed activities are consistent with this policy. No new buildings or permanent structures are proposed in association with the in-water remediation. Temporary structures will be designed by a New York State Professional Engineer in a manner consistent with development within a Federal Emergency Management Agency (FEMA) 100-year flood zone. River and weather conditions will be monitored during remedial activities and appropriate site securing measures will be taken in the event of an anticipated flooding event on the Hudson River.

POLICY 12: Activities or development in the coastal area will be undertaken so as to minimize damage to natural resources and property from flooding and erosion by protecting natural protective features including beaches, dunes, barrier islands and bluffs

The proposed activities are consistent with this policy. Remedial activities, consisting of dredging, and installation of a clean sand cap placement in the Hudson River and concrete and reactive mat caps on the river bank and over the underwater utility crossings will be conducted. Specific measures will be employed to minimize damage due to flooding and erosion during temporary project activities. These measures include; installation of turbidity curtains during dredging, off-site disposal of dredged material, as well as the required environmental monitoring of water quality during dredging activities. No natural protective features will be damaged by the proposed activities. No beaches, dunes, barrier islands or bluffs are present in the project area.

POLICY 15: Mining, excavation or dredging in coastal waters shall not significantly interfere with the natural coastal processes which supply beach materials to land adjacent to such waters and shall be undertaken in a manner which will not cause an increase in erosion of such land

The proposed activities are consistent with this policy. The proposed work will consist of dredging of fine grained sediment within the Hudson River. After dredging, clean sand from an upland source will be placed on the dredged areas using specially fabricated conveyors to help restore the pre-dredging contours. Regrading of the side slope along the river will be conducted in an area of approximately 1.2 acres. The regraded slope will be covered with grout-filled mats underlain by organoclay Reactive Core Mat[®] (RCM) to minimize erosion.

POLICY 19: Protect, maintain, and increase the level and types of access to public water related recreation resources and facilities.

The proposed activities are consistent with this policy. The former North Water Street manufactured gas plant (MGP) site and dredging areas are located beneath the Walkway Over the Hudson State Historic Park and adjacent to the Upper Landing Park. The proposed project

will not result in reduction of existing access from adjacent or proximate public lands or facilities to public water-related recreation resources and facilities, nor will it eliminate the possibility of increasing access in the future from adjacent or proximate public lands or facilities to public water-related recreation resources and facilities.

POLICY 20: Access to the publicly-owned foreshore and to lands immediately adjacent to the foreshore or the water's edge that are publicly-owned shall be provided and it shall be provided in a manner compatible with adjoining uses

The proposed activities are consistent with this policy. The former MGP site and dredging areas are located beneath the Walkway Over the Hudson State Historic Park and adjacent to the Upper Landing Park. The proposed activities take place on private property and in the Hudson River. The proposed project will not result in reduction of existing access from adjacent or proximate public lands or facilities to existing public coastal lands and/or waters, nor will it eliminate the possibility of increasing access in the future from adjacent or nearby public lands or facilities to public coastal lands and/or waters.

POLICY 21: Water dependent and water enhanced recreation will be encouraged and facilitated, and will be given priority over non-water-related uses along the coast

The proposed activities are consistent with this policy. As the proposed work consists of the dredging of impacted sediment within the river, as well as the river bank slope grading and placement of reactive mats on the banks along the Hudson River near the former MGP site, this project is considered water-dependent as it can only be conducted within the water body. Given the purpose and need for this project (dredging impacted materials and cap installation) as required by the NYSDEC Decision Document, the siting option is necessary to conduct the work. The work will be consistent with the policy as it will not restrict the recreational use of coast and water. After the project activities have been completed, water dependent and water enhanced recreation opportunities will be facilitated by removing impacted sediments and stabilizing the bank slope.

POLICY 22: Development when located adjacent to the shore will provide for water-related recreation whenever such use is compatible with reasonably anticipated demand for such activities, and is compatible with the primary purpose of the development

This policy is not applicable. The project consists of remediation of impacted sediments within the Hudson River and habitat restoration; no new riverfront development is proposed. The proposed activities would not preclude future water-related recreation opportunities at the Site.

POLICY 23: Protect, enhance and restore structures, districts, areas or sites that are of significance in the history, architecture, archeology or culture of the State, its communities, or the Nation.

The CHGE property is not listed on, or potentially eligible for listing on, the National Register of Historic Places. The CHGE property and the dredging areas are located beneath the Walkway

Over the Hudson bridge, which is a listed National Register Historic Places. In addition, the former MGP site is approximately 200 feet southwest of the Hoffman Home and Grounds which are listed on the National Registry of Historic Places. The CHGE project activity (dredging of impacted material, grading of the river bank, and placement of reactive mats on the river slope and over the underwater utility crossings) will have no adverse effect on the listed properties. A Section 106 Consultation letter and relevant CRIS search results have been submitted to the New York State Office of Parks, Recreation and Historic Preservation (NYS OPRHP) office; the office responded with recommendation of a magnetometer survey and inspection of the targets identified during the sonar survey by divers. Diving investigation is completed and a magnetometer survey is not feasible due to the presence of the iron Walkway over Hudson bridge. A response to these recommendations is being prepared and will be submitted to the NYS OPRHP following submission to the NYS OPRHP.

POLICY 24: Prevent impairment of scenic resources of statewide significance.

The proposed activities are consistent with this policy. The Hudson River is identified on the coastal area map scenic resources of statewide significance. The proposed project is the dredging of sediments, regrading of river bank slope, and placement of cap over the river bank slope and utility crossing. The dredging and utility capping are underwater activities. The river bank grading and capping is 90% underwater with no visible change to the existing shoreline. The river bank grading will stabilize the river bank thus preventing eroding of the bank. Thus the proposed construction of the replacement steel bulkhead would not affect the Hudson River.

POLICY 28: Ice management practices shall not interfere with the production of hydroelectric power, damage significant fish and wildlife and their habitats, or increase shoreline erosion or flooding

The proposed activities are consistent with this policy. Winter work conducted at the site may consist of dredging and the placement of cap material. Project activities will not be conducted that would require ice management that may affect hydroelectric power, ecological resources, or shoreline erosion or flooding.

POLICY 30: Municipal, industrial, and commercial discharge of pollutants, including but not limited to, toxic and hazardous substances, into coastal waters will conform to State and National water quality standards

This policy is not applicable. Project activities are related to the remediation of impacted sediment; pollutants will not be discharged into coastal waters.

POLICY 35: Dredging and filling in coastal waters and disposal of dredged material will be undertaken in a manner that meets existing State dredging permit requirements, and protects significant fish and wildlife habitats, scenic resources, natural protective features, important agricultural lands, and wetlands

The proposed activities are consistent with this policy. The proposed work includes dredging and filling operations proposed in the Hudson River as required by the NYSDEC 2016 Decision Document. CHGE is currently in coordination with the appropriate regulatory agencies

to obtain all required environmental authorizations for the proposed remediation work, ensuring proper protection of valuable coastal resource areas.

POLICY 36: Activities related to the shipment and storage of petroleum and other hazardous materials will be conducted in a manner that will prevent or at least minimize spills into coastal waters; all practicable efforts will be undertaken to expedite the cleanup of such discharges; and restitution for damages will be required when these spills occur.

The proposed activities are consistent with this policy. The waste handling and disposal activities will be performed in accordance with applicable federal, state, and local regulatory requirements. The temporary storage, on-site treatment and disposal of solid wastes and hazardous materials will be conducted in a manner to protect the groundwater and surface water supply, and significant fish and wildlife habitat in the Hudson River.

Following dredging and gravity dewatering at the dredging site, impacted sediments will be transferred into barges for transport to a disposal facility permitted to receive and process this material. The dredged material may be blended with stabilization materials (e.g., Portland cement or other approved stabilizing agent) at the facility as necessary to meet the selected disposal facility's acceptance criteria. Best waste management techniques will be utilized to avoid or minimize any spills.

A Spill/Release Prevention and Response Plan will discuss spill prevention techniques and present the procedures to be followed if a spill or release occurs during performance of the remedial action at the work area. Spill containment and response equipment will be located on-site to handle spills or releases (e.g., fluids from heavy equipment, on-site chemicals, and site-related constituents) that may occur during performance of the work.

POLICY 38: The quality and quantity of surface water and groundwater supplies, will be conserved and protected, particularly where such waters constitute the primary or sole source of water supply

The proposed activities are consistent with this policy. Targeted river sediments will be dredged using an environmental bucket, which is designed to provide flat dredge cuts for maximum control of the dredged surface and seals around the bucket to limit loss of material as the bucket is raised through the water column. All dredging will take place within a containment cell outfitted with turbidity curtains and floating booms on all sides to control any turbidity generated during dredging. Water quality (turbidity) will be monitored for the duration of the dredging by means of three buoy-mounted remote sensing stations that will be moored around the perimeter of the work area. Dredged areas will then be backfilled with certified clean sand imported from upland sources and transported to the site via barge. The clean sand will be placed on the dredged areas using specially fabricated conveyors.

Along the shoreline and over the underwater utility crossings, where dredging is not feasible, impacted material containment will be provided through capping. The cap will be placed along the entirety of the affected riverbank slope (approximately 1.2 acres) and over portions of the

underwater utility crossings (approximately 1.1 acres). An articulated cap will then be constructed using an innovative subaqueous forming system where interlocking fabric molds attached to RCM are assembled on land in large segments, and then placed on the slope and over utility crossings underwater. Once placed on the slope, the individual segments will be interlocked by a diver and grout will be pumped into the molds via tremie lines. Pre-manufactured armor mat and RCM assemblies will be placed over the segments over the utility crossings.

POLICY 39: The transport, storage, treatment and disposal of solid wastes, particularly hazardous wastes, within coastal areas will be conducted in such a manner so as to protect groundwater and surface water supplies, significant fish and wildlife habitats, recreation areas, important agricultural land, and scenic resources

The proposed activities are consistent with this policy. As stated in the response regarding Policy 36, the waste handling and disposal activities will be performed in accordance with applicable federal, state, and local regulatory requirements to protect natural resources.

POLICY 40: Effluent discharged from major steam electric generating and industrial facilities into coastal waters will not be unduly injurious to fish and wildlife and shall conform to state water quality standards

This policy is not applicable. Project activities are related specifically to the remediation of impacted sediment within the Hudson River adjacent to the former MGP site. No activities related to steam electric generating or industrial facility discharges are proposed.

POLICY 44: Preserve and protect tidal and freshwater wetlands and preserve the benefits derived from these areas

This policy is not applicable. The project is proposed to remediate contaminated sediments adjacent to the for MGP site. Federal and state wetland mapping do not identify any freshwater or tidal wetlands in or near the work area.

Habitat Impairment Test Provided on Following Page

Habitat Impairment Test

Habitat Impairment Test

Kingston- Poughkeepsie Deepwater River Significant Coastal Fish and Wildlife Habitat

1 Introduction

The Central Hudson Gas & Electric Corporation (CHGE) former North Water Street manufactured gas plant (MGP) site is located at 2 Dutchess Avenue in the City of Poughkeepsie, Dutchess County, New York (Figure 1). The site is bounded by Dutchess Avenue to the north, North Water Street and Amtrak railroad lines to the east, the City of Poughkeepsie Upper Landing Park and Fall Kill Creek to the south, and the Hudson River to the west. Tidal movements affect the Hudson River adjacent to the site. Depths in the river within the project area are generally over 40 feet deep (Figure 2).

The site was operated as a carbureted water gas MGP from 1911 to 1950. CHGE has owned the site since 1926. During peak operation, waste by-products were recycled at the site, and during this process, by-products were reported to have seeped into the Hudson River from unintentional spills near the tar separator. To prevent additional seepage of by-products into the river, a clay dike was installed between the railroad siding and the river in the 1940s. Today, residuals from these releases are in the form of non-aqueous phase liquid (NAPL); more specifically dense non-aqueous phase liquid (DNAPL) is the primary form of site contamination to be addressed.

Of the remedial activities listed above, the dredging and capping activities in the Hudson River and along the river side slope are subject to Nationwide Permit (NWP) 38 and described here. Approximately 7.6 acres of dredging would be conducted to remove approximately 40,000 cubic yards (CYs) of sediment impacted by the operation of the former MGP facility (Figure 3). Dredging of the contaminated sediments that are visually impacted with NAPL are anticipated to be conducted between October 2018 through February 2019. Of the 40,000 CYs to be dredged, approximately 20,000 CYs will be removed in a 4 acre area of the Kingston-Poughkeepsie Deepwater Habitat, Significant Coastal Fish and Wildlife Habitat.

Dredging will be conducted using an environmental bucket within a containment cell mounted to the dredge, which will be outfitted with turbidity curtains and floating booms on all sides to control the transport of contaminated sediment beyond the dredging area. Figure 4 shows the curtain detail of the containment cell. Water quality (turbidity) will be monitored for the duration of the dredging by means of three buoy-mounted remote sensing stations that will be moored around the perimeter of the work area.

Dredged areas deeper than 2 feet below the existing bathymetry will then be backfilled after dredging with certified clean sand (approximately 31,000 CYs) imported from upland sources and transported to the site via barge to support restoration of the river bottom to pre-dredge bathymetry. The clean sand will be placed on approximately 4.2 acres of the dredged areas using specially-fabricated conveyors and tremie technology that will discharge backfill material from a tremie pipe above the dredge surface as deep as possible.

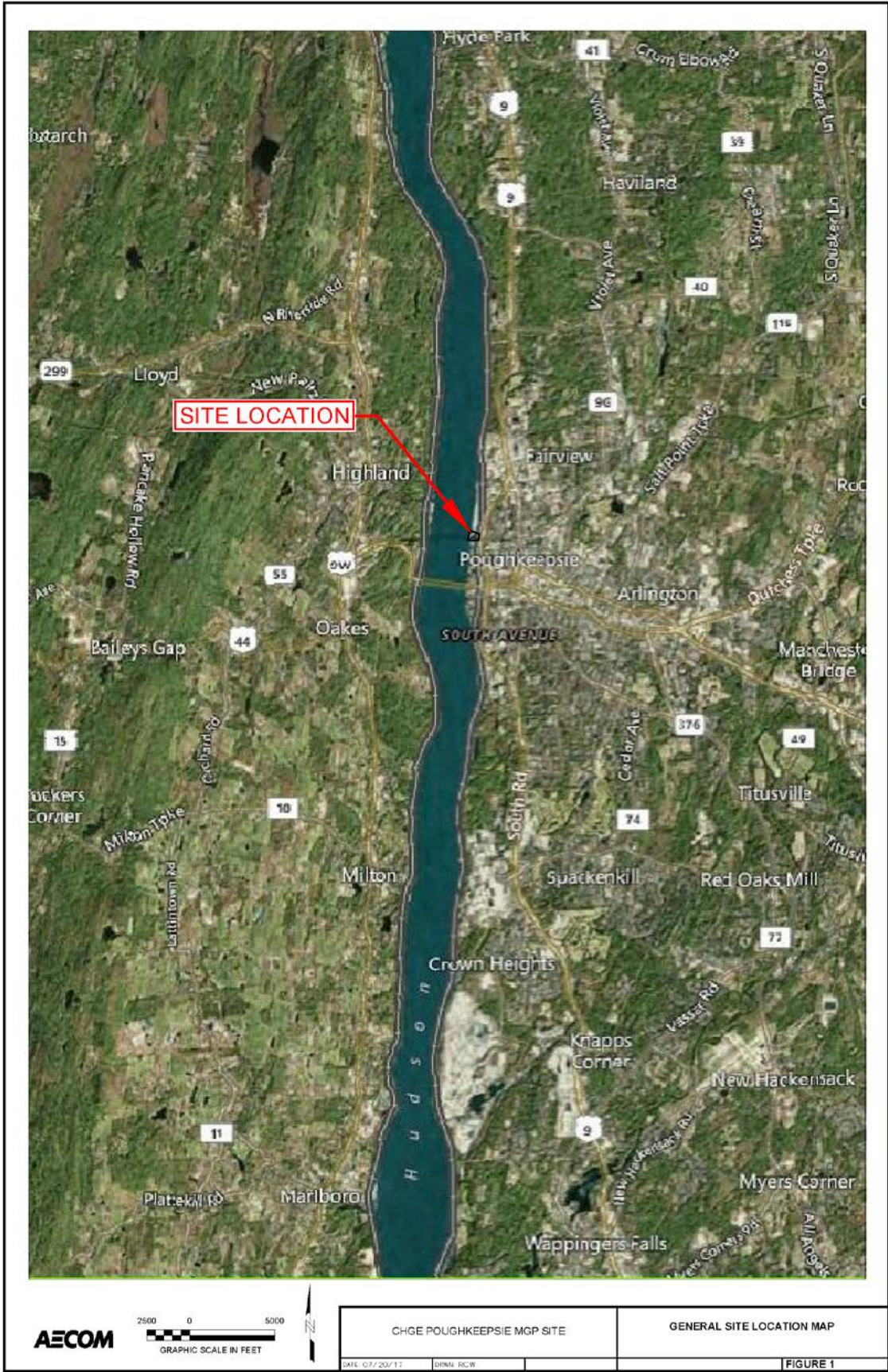

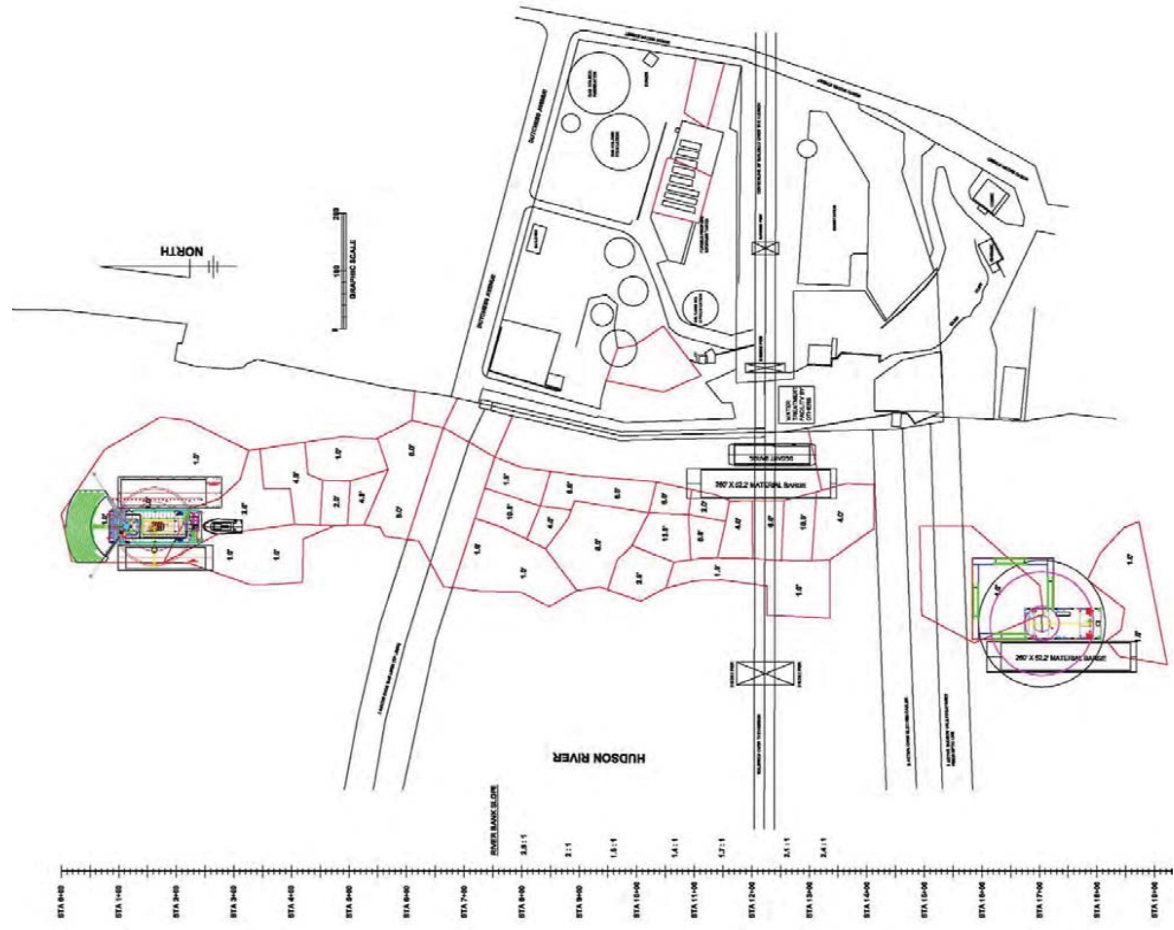

**CHGE POUGHKEEPSIE MGP SITE
REMEDIAL ACTION RFP**

DATE: 12/06/16

DREDGE PLAN

FIGURE 3

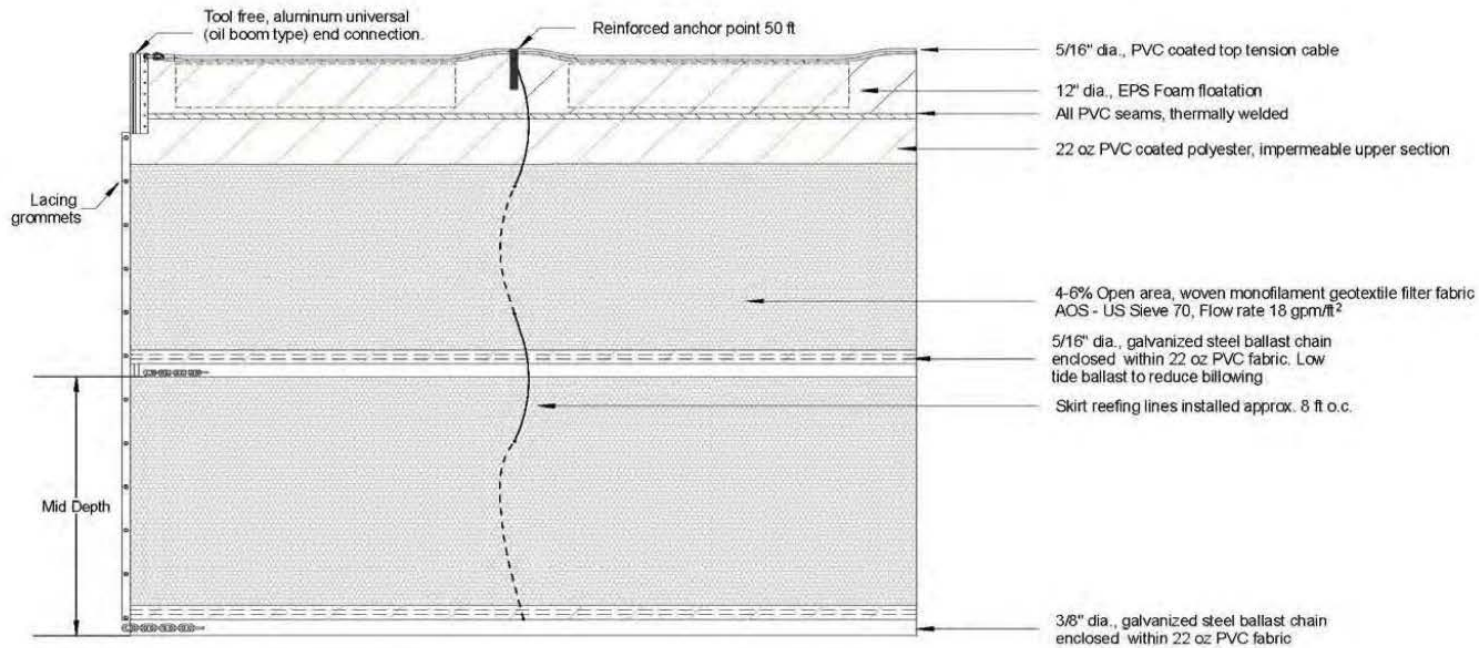
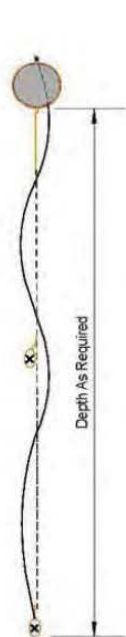

TURBIDITY BARRIER DETAIL
N.T.S.



CHGE POUGHKEEPSIE MGP SITE REMEDIAL ACTION RFP		CURTAIN DETAIL	
DATE: 12/06/16		FIGURE 4	

The backfill will consist of clean sand, a granular material of sufficient size and density that it is expected to fall to the river bottom at its placement location with minimal dispersion. Clean sand was selected specifically to maximize accuracy of the fill placement operation and minimize suspension and transport of backfill material outside of the intended placement location to help restore the bottom contours to pre-dredging conditions.

The river bottom will be allowed to reestablish its original (pre-dredging) bathymetry within dredged areas by natural sediment transport processes to a depth of up to two feet. Sediment deposition and subsequent erosion is a natural cycle within a stable riverbed; while specific rates of sedimentation and erosion in the vicinity of Poughkeepsie are not available, sedimentation rates of approximately 40 centimeters (1.3 feet) within a period of months (typically, during the spring freshet) are observed within the Lower Hudson River as a whole, based on literature review. Excavations that depress portions of the river bottom below the surrounding bathymetry also function as natural sediment traps; consequently, it is expected that sediment transport within the dredged areas will be depositional only in nature until the pre-existing stable bathymetry is restored, after which the natural long-term deposition and erosion cycle will resume.

Review of the New York State Department of State Significant Coastal Fish and Wildlife Habitats (SCFWH) Maps indicates that dredging will occur within approximately four acres of the 6,350-acre Kingston-Poughkeepsie Deepwater River (NYSDOS, 2012). The significant habitat area is a nearly continuous deepwater section of the river ranging in water depth from 20 feet to 50 feet or greater.

2 Habitat Impairment Test

A habitat impairment test must be met for any activity that is subject to consistency review under federal and state laws, or under applicable local laws contained in an approved local waterfront revitalization program. If the proposed action is subject to consistency review, then the habitat protection policy applies, whether the proposed action is to occur within or outside the designated area. The specific habitat impairment test that must be met is as follows.

In order to protect and preserve a significant habitat, land and water uses or development shall not be undertaken if such actions would destroy the habitat or significantly impair the viability of a habitat.

- **Destroy the habitat** – Habitat destruction is defined as the loss of fish or wildlife use through direct physical alteration, disturbance, or pollution of a designated area or through the indirect effects of these actions on a designated area. Habitat destruction may be indicated by changes in vegetation, substrate, or hydrology, or increases in runoff, erosion, sedimentation, or pollutants.
- **Significantly Impair The Viability Of A Habitat** - Significant impairment is defined as reduction in vital resources (e.g., food, shelter, living space) or change in environmental conditions (e.g., temperature, substrate, salinity) beyond the tolerance range of an organism. Indicators of a significantly impaired habitat focus on ecological alterations and may include but are not limited to reduced carrying capacity, changes in community structure (food chain relationships, species diversity), reduced productivity and/or increased incidence of disease and mortality.

3 Impact Assessment

As per the NYSDOS' *Coastal Fish & Wildlife Habitat Rating Form* for the Kingston-Poughkeepsie Deepwater Habitat, the following potentially adverse activities and impacts should be considered in applying the habitat impairment test to a proposed activity.

1. Any activity that would substantially degrade water quality, increase turbidity or sedimentation, alter flows, salinity, or temperature, reduce water depths, or degrade or alter benthic communities in Kingston-Poughkeepsie Deepwater would result in significant impairment of the habitat. All species may be affected by water pollution, such as chemical contamination (including food chain effects resulting from bioaccumulation), oil spills, excessive turbidity or sediment loading, nonpoint source runoff, and waste disposal (including vessel wastes). Discharges or runoff of sewage effluent, pesticides, or other hazardous materials into the river may result in adverse impacts on the habitat area.
2. Any physical alteration of the habitat through dredging or filling (including dredge spoil disposal), would result in a direct loss of valuable habitat. Such activities could have significant impacts on striped bass and sturgeon populations during spawning, and incubation periods (May-July, primarily) and overwintering times. Habitat disturbances would be most detrimental during fish spawning and nursery periods, which generally extend from April through August for most warm water species.
3. Thermal impacts could have adverse effects on use of the area by migratory and resident species. Activities that result in the presence of significant electric, or magnetic, or electromagnetic field may affect benthic communities, migratory fish movement, and fish egg and larval development. Entrainment and impingement causes significant mortality to all life stages of fish, including endangered species. Activities that would enhance migratory, spawning, or nursery fish habitat, particularly where an area is essential to a species' life cycle or helps to restore an historic species population would be beneficial.

Dredging activities within the SCFWH area are limited to approximately 20,000 CYs within approximately four acres. Turbidity beyond the dredging area will be controlled by using an environmental bucket within a containment cell which will be outfitted with turbidity curtains that extend to the river bottom and floating booms on all sides. In addition, because dredging activities are anticipated to be conducted between October and February, disturbances during spawning, incubation, and nursing periods are unlikely to occur. Less intrusive capping activities are proposed between July and September though the small footprint of these activities and non-intrusive nature are not anticipated to have any adverse effects. Temporary water quality impacts from an increase in turbidity and/or sedimentation may occur during dredging activities but will be minor and short term. Moreover, the removal of sediments known to contain potentially ecologically-threatening constituents would provide long-term benefits to the fauna of the deepwater habitat which transit through the Hudson River.

3.1 Endangered Species Overwintering, Spawning, and Foraging Habitat

The Kingston-Poughkeepsie Deepwater Habitat is one of the largest and most well-known spawning areas for Atlantic sturgeon (*Acipenser oxyrinchus*) and overwintering areas for shortnose sturgeon (*Acipenser*

brevirostrum) in the Hudson River. Although habitat requirements of both sturgeon species are still being studied, it is believed that these deepwater areas may be critical year round. Yolk-sac larvae, suspected to be Atlantic sturgeon, have been collected from this region at depths of 45 feet to 120 feet. Mature Atlantic sturgeon have been routinely captured in deep water on both sides of the river near the middle and near the southern end of the habitat area. Spawning also occurs in deep water along the southern east shore of the river. Shortnose sturgeon use the portion of the river that generally is greater than 30 feet in depth. The majority of both Atlantic sturgeon and shortnose sturgeon taken for age-growth analysis during the biological survey in the 1930s came from within this habitat near Rhinecliff and Port Ewen. The Kingston- Poughkeepsie Deepwater Habitat also encompasses the reach of highest mean striped bass egg density from 1974-2006. Striped bass spawning over deepwater has been observed in this reach of the river.

Based on the Atlantic sturgeon and shortnose sturgeon life cycles, with regard to spawning habitat and overwintering areas, dredge work activities will be limited to the timeframe when these species are less likely to be present in the site area (October through February), to avoid the overwintering near Kingston and the migration to the spawning grounds. Moreover, given the size of the dredging area relative to the overall habitat, potential disruption to the Atlantic sturgeon and shortnose sturgeon is expected to be insignificant.

3.2 Deepwater Habitat

The Kingston-Poughkeepsie Deepwater Habitat is a nearly continuous deepwater section of the river, from a water depth of 20 feet to the bottom, and especially where water depths of 50 feet or greater occur. The Kingston-Poughkeepsie Deepwater Habitat is the northernmost extensive section of deepwater habitat in the Hudson River. Deepwater areas support a diversity of freshwater and migratory species in the Hudson River. In addition to Atlantic sturgeon and shortnose sturgeon, fish species found in this section of river include fourspine stickleback (*Apeltes quadracus*), hogchoker (*Trinectes maculatus*), killifish (*Fundulus diaphanous*), threespine stickleback (*Gasterosteus aculeatus*), white perch (*Morone americana*), bluegill (*Lepomis macrochirus*), brown bullhead (*Ameiurus nebulosus*), common carp (*Cyprinus carpio*), golden shiner (*Notemigonus crysoleucas*), largemouth bass (*Micropterus salmoides*), pumpkinseed (*Lepomis gibbosus*), smallmouth bass (*Micropterus dolomieu*), spottail shiner (*Notropis hudsonius*), white catfish (*Ameiurus catus*), yellow perch (*Perca flavescens*), alewife (*Alosa pseudoharengus*), American eel (*Anguilla rostrata*), American shad (*Alosa sapidissima*), blueback herring (*Alosa aestivalis*), and striped bass (*Morone saxatilis*). However, salinities within the project area are generally less than 5.0 parts per thousand, which would exclude the presence of many marine and estuarine species. Any impacts to deepwater habitat during construction activities is expected to be minor and temporary.

3.3 Blue Crab and Waterfowl Habitat

The Kingston-Poughkeepsie Deepwater Habitat area provides habitat for blue crab (*Callinectes sapidus*) and concentrations of waterfowl such as American black duck (*Anas rubripes*), blue-winged teal (*Anas discors*), common goldeneye (*Bucephala clangula*), common merganser (*Mergus merganser*), gadwall (*Anas strepera*), greater scaup (*Aythya marila*), green-winged teal (*Anas crecca*), hooded merganser (*Lophodytes cucullatus*), lesser scaup (*Aythya affinis*), mallard (*Anas platyrhynchos*), northern pintail (*Anas acuta*), red-breasted merganser (*Mergus serrator*), and wood duck (*Aix sponsa*). Shallow water

areas, protected inlets, marshes or other habitats favored by waterfowl do not occur within and/or immediately adjacent to the project area. Impacts to waterfowl habitat from dredging activities are not expected during the project.

Although some blue crab habitat disruption will occur during dredging activities, the long-term benefit will be gained by reducing areas of sediments known to contain potentially ecologically-threatening constituents. The dredging will occur only in a small portion of the deepwater habitat, allowing any affected organisms to temporarily relocate during project activities. It is anticipated that restoration of the dredged areas with clean backfill materials, along with natural sedimentation processes will allow for the re-colonization of organisms. The re-colonization within the dredge area substrates will provide benthic habitat and food sources. To further minimize the potential impacts of the remediation activities, the dredging will occur during times of the year when bottom feeders are unlikely to be present in the dredging area.

4 Conclusion

The dredging activities associated with this project would not result in long-term or permanent habitat destruction or significantly reduce the viability of the SCFWH. The limited and temporary disturbance of approximately four acres of the SCFWH, the timing of activities to protect species during critical life stages, and the use of BMPs would result in very minor and temporary ecological impacts.

In addition, the removal of toxins associated with NAPL-laden sediments would have positive long-term benefits for the habitat. Also, the placement of capping materials on the slope would increase benthic rugosity allowing for hard substrates to be colonized by sessile organisms and provided vertical relief for motile aquatic organisms to use as a habitat structure.

Attachment 6

New York State Historic Preservation Office (SHPO)

Review



Parks, Recreation, and Historic Preservation

ANDREW M. CUOMO
Governor

ROSE HARVEY
Commissioner

December 21, 2017

Ms. Nancy Stehling
Senior Archaeologist
AECOM
125 Broad Street
15th Floor
New York, NY 10004

Re: USACE
Central Hudson Gas & Electric Corp, Former North Water Street Manufactured Gas Plant Site, Dredging of Contaminated Soil and Sediment, Sideslope Grading and Capping, and Utility Capping in the Hudson River
City of Poughkeepsie, Dutchess County, NY
17PR08473

Dear Ms. Stehling:

Thank you for requesting the comments of the New York State Historic Preservation Office (SHPO). We have reviewed the submitted materials in accordance with Section 106 of the National Historic Preservation Act of 1966. These comments are those of the SHPO and relate only to Historic/Cultural resources. They do not include other environmental impacts to New York State Parkland that may be involved in or near your project. Such impacts must be considered as part of the environmental review of the project pursuant to the National Environmental Policy Act and/or the State Environmental Quality Review Act (New York Environmental Conservation Law Article 8).

SHPO has reviewed the initial submission for this project (Stehling, 15 December 2017). We have the following comments.

1. The project description indicates that the proposed dredging depths range between 1 foot and 13 feet. However, the sonar survey only detects objects at the surface of the river bottom. Other objects may be buried in the silt which could be affected by the planned dredging. Therefore, we recommend that a magnetometer survey be undertaken, with results interpreted by an experienced marine archaeologist.
2. A number of targets were identified by the sonar survey that are not within the planned dredge areas. Could these be impacted by the work barge anchors or other underwater actions?
3. For those targets identified during the sonar survey, we recommend that consideration be given to having these inspected by a diver with the aim of obtaining a more definitive identification.

We have no concerns regarding architectural resources.

Division for Historic Preservation

P.O. Box 189, Waterford, New York 12188-0189 • (518) 237-8643 • www.nysparks.com

If you have any questions, please don't hesitate to contact me.

Sincerely,

A handwritten signature in black ink, reading "Philip A. Perazio". The signature is written in a cursive style with a large initial "P".

Philip A. Perazio, Historic Preservation Program Analyst - Archaeology Unit

Phone: 518-268-2175

e-mail: philip.perazio@parks.ny.gov

via e-mail only

cc: Robert Forstner, James Mansky, and Shail Pandya, AECOM
Jesse Gallo and Mark McLean, Central Hudson



AECOM
125 Broad Street
New York, NY 10004
www.aecom.com

212 377 8400 tel
212 377 8410 fax

December 15, 2017

Mr. Tim Lloyd
New York State Division for Historic Preservation
New York State Office of Parks, Recreation and Historic Preservation
Peebles Island State Park
P.O. Box 189
Waterford, NY 12188-0189

**RE: Section 106 Consultation
Dredging of Contaminated Soil and Sediment, Sideslope Grading and Capping, and Utility
Capping in the Hudson River
Central Hudson Gas & Electric Corporation
Former North Water Street Manufactured Gas Plant Site
North Water Street and Dutchess Avenue, Poughkeepsie, New York**

Dear Mr. Lloyd,

On behalf of Central Hudson Gas & Electric Corporation (CHGE), AECOM is evaluating potential impacts to cultural resources associated with remediation of the former CHGE Manufactured Gas Plant (MGP) site at North Water Street and Dutchess Avenue in Poughkeepsie, New York. The planned remediation includes work in the Hudson River, for which an application for authorization under US Army Corps of Engineers Nationwide Permit (NWP) #38 will be made.

CHGE owns the upland portion of the project site, which is approximately 13 acres in size and is bounded by the Hudson River to the west, Dutchess Avenue to the north, North Water Street and Amtrak to the east, and the City of Poughkeepsie Upper Landing Park and Fallkill Creek to the south. The planned activities include underwater dredging of the river bottom in discrete areas (totaling approximately 7.9 acres); sideslope grading and capping adjacent to the bulkhead on the east bank of the river (approximately 1.5 acres); and capping of utility corridors that fall within proposed dredging footprints (approximately 1.1 acres).

The proposed dredging depths vary along the in-river work footprint, and were developed based on the depth of impacted sediments at the discrete locations. A total of 28 dredge prisms were developed across the in-river work footprint and the proposed dredging depths range between 1 foot and 13 feet. A map depicting the dredge prisms and a table detailing the breakdown of each prism by surface area, volume of sediment to be removed, and maximum depth of dredging is included in the attached memorandum.

Dredging of impacted sediment will be performed using an environmental bucket within a containment cell mounted to a platform barge. In addition, the barge will be outfitted with turbidity curtains and floating booms positioned on all sides to control the transport of contaminated sediment beyond the dredging area. All dredged material will be dewatered at the site and transported off site via barge for ultimate treatment and disposal. Following removal, all dredged areas will be backfilled with certified clean fill material to within approximately two feet of the pre-dredging elevations.

This letter and the attached memorandum that includes the figure showing the proposed locations of all underwater activities, the map and accompanying table of dredge prisms, the results of the CRIS search for the project area, the results of a 2017 bathymetric survey of the proposed in-river work area, and photographs of the project area vicinity are being sent to you to initiate the consultation process in accordance with Section 106 of the National Historic Preservation Act.

Please review the attached information and provide us with the State Historic Preservation Office's comments on the project with regard to the need for any cultural resources surveys that should be completed to ensure CHGE's compliance with Section 106.

Thank you for your assistance with this project. If you have any questions or require additional information, please feel free to contact me at nancy.stehling@aecom.com or at 212.377.8722.

Sincerely,



Nancy A. Stehling, RPA
Senior Archaeologist
Environment
AECOM
125 Broad Street
New York, NY 10004

Email: nancy.stehling@aecom.com
Direct Line: 212.377.8722

cc: Shail Pandya, AECOM
Robert Forstner, AECOM
James Mansky, AECOM
Mark L. McLean, CHGE
Jesse Gallo, CHGE

Central Hudson Gas & Electric Corporation

Fomer North Water Street Manufactured Gas Plant Site

Dredging of Contaminated Soil and Sediment, Sideslope Grading and Capping, and Utility Capping in the Hudson River

**North Water Street and Dutchess Avenue
Poughkeepsie, New York**

INTRODUCTION

The project site is the Central Hudson Gas & Electric Corporation (CHGE) former “North Water Street” Manufactured Gas Plant (MGP) site (Figure 1), located on the east bank of the Hudson River at the intersection of North Water Street and Dutchess Avenue in Poughkeepsie, New York. CHGE owns the upland portion of the project site, which is approximately 13 acres in size and is bounded by: the Hudson River to the west, Dutchess Avenue to the north, North Water Street and Amtrak to the east, and the City of Poughkeepsie Upper Landing Park and Fallkill Creek to the south (Figure 1). Currently, CHGE operates a natural gas regulator station on the northwest portion of the site and an electric transition and substation on the southern/eastern portion of the site. Most of the project site has a gravel cover or is paved. All of the buildings associated with the MGP have been removed from the site.

The project site housed a large MGP facility from 1911 to the mid-1950s. Contamination from the gas manufacturing process leaked from storage vessels and piping, and is still present in the subsurface and in Hudson River sediments. CHGE is responsible for the cleanup of the contamination under the voluntary New York State Brownfield Cleanup Program (BCP). The New York State Department of Environmental Conservation (NYSDEC) issued a Decision Document in 2016 that requires CHGE to implement a remedial action.

CHGE is requesting a US Army Corps of Engineers Nationwide Permit #38 to carry out the in-river tasks associated with site remediation.

AECOM, on behalf of CHGE, is evaluating potential impacts to cultural resources associated with the proposed in-river remediation work. This memorandum is concerned with the potential effects of the project actions on cultural resources to ensure CHGE’s compliance with Section 106 of the National Historic Preservation Act.

EXISTING CONDITIONS

The upland portion of the project site consists of two relatively flat terraces, separated by steep, rocky slopes with very thin soil cover. The lower terrace lies on the banks of the Hudson River, roughly 5-10 feet above sea level. The upper terrace is roughly 50 feet higher, bordering North Water Street. The riverbank is steep adjacent to the project site. Currently, the only building located on the project site is an unoccupied cinder block valve house associated with the natural gas regulator station.

Important utility lines, including a fiber optic line, are located on the project site. Both natural gas transmission pipelines and electric transmission lines cross beneath the Hudson River at this location, and connect with natural gas and electrical lines which serve much wider areas surrounding Poughkeepsie. An electrical transmission transition station is located on the lower terrace at the southwestern portion of the project site, where the electrical transmission line meets the shoreline and a natural gas regulator station occupies the northwestern corner of the lower terrace of the site where the natural gas transmission pipeline meets the shoreline (Photos 1 and 2). A fence encloses the transition and regulator stations.

Based on the and observations findings during the pre-design investigation,, impacted sediments generally extend between 200 and 400 feet into the Hudson River from the shoreline, and are primarily located within the upper 3 to 7 feet of sediment.

REGULATORY PROCESS

Remediation of the former MGP is being conducted in accordance with the NYSDEC *Decision Document for the Central Hudson Water Street Brown Field Cleanup Program Site No. C314070* (March 2016).

A US Army Corps of Engineers Nationwide Permit (NWP) #38 is required to conduct the in-river work tasks that include dredging, slope grading and capping, and utility capping along the Hudson River shoreline and river bottom adjacent to the former MGP site. As part of this permitting process, AECOM has prepared the NYS DEC's Structural Archaeological Assessment Form (SAAF) for the project.

PROJECT ACTIONS

The planned activities underwater include:

- Dredging of the river bottom in discrete areas (totaling approximately 7.9 acres).
- Sideslope grading and capping adjacent to the bulkhead on the east bank of the river (approximately 1.5 acres).
- Capping of utility corridors that fall within proposed dredging footprints (approximately 1.1 acres).

Figure 2 depicts the proposed in-river activities. Photos 1-8 show the project area and vicinity.

Dredging

The proposed dredging depths vary along the in-river work footprint, and were developed based on the depth of impacted sediments at the discrete locations. A total of 28 dredge prisms were developed across the in-river work footprint, and the proposed dredging depths range between 1 foot and 13 feet. Figure 3 depicts the 28 dredge prisms and Table 2 details the breakdown of each prism by surface area, volume of sediment to be removed, and maximum depth of dredging.

Dredging of impacted sediment will be performed using an environmental bucket within a containment cell mounted to a platform barge. In addition, the barge will be outfitted with turbidity curtains and floating booms positioned on all sides to control the transport of contaminated sediment beyond the dredging area. All dredged material will be dewatered at the site and transported off site for ultimate treatment and disposal. Following removal, all dredged areas will be backfilled with certified clean fill material to within approximately two feet of the pre-dredging elevations.

Sideslope Grading and Capping

As shown on Figure 2, the the sideslope grading and capping areas are located waterward of the existing bulkhead on the east bank of the river. The shoreline along the project site cannot be dredged due to stability concerns; therefore, approximately 1.5 acres of reactive core mats overlain by grout-filled

blankets will be installed along the slope to isolate impacted soils and sediments remaining outside of the bulkhead from the river.

Utility Capping

As shown on Figure 2, the utility capping is proposed for those areas of the river where the underwater fiber optic and gas lines traverse proposed dredging areas. Dredging cannot be conducted in the areas of existing utility lines that cross the Hudson River; therefore, approximately 1.1 acres of area over and around the utility lines will be capped with reactive core mats overlain by concrete block mattresses to isolate the impacted sediment.

Best Management Practices (BMPs) and engineering controls, including the containment cell for the dredging activity, will be utilized throughout the work in the Hudson River.

RESULTS OF CRIS SEARCH

The CRIS search indicates that the project site lies beneath the National Register-listed Poughkeepsie Railroad Bridge (90NR00370), now repurposed as the Walkway Over the Hudson bridge. According to the 1968 NYS Historic Site Form, this bridge is a truss and cantilever type railroad bridge built for the New York, New Haven and Hartford Railroad between 1873 and 1888. This was the first bridge spanning the Hudson River between New York City and Albany. It spans 2,608 feet of water and is 6,767 feet long altogether. It is supported 214 feet above the Hudson River by six piers, and was still carrying freight in 1968. The bridge was officially completed, after three changes in contractors, on August 29, 1888. The bridge ceased to function as a railroad bridge in 1974, when a fire caused substantial damage to a portion of the deck.

The former railroad bridge has been adaptively repurposed as a pedestrian walkway. In October 2009, the Walkway Over the Hudson State Historic Park opened as a legacy project of the Hudson-Fulton-Champlain Quadricentennial. The park offers interpretive signs and a Talkway Over the Walkway cell phone tour.

The in-river work will not directly affect the overhead National Register-listed bridge and it is very unlikely that the project would create any indirect effects to either the bridge itself or its historic setting.

There is one National Register-eligible aboveground historic resource located within a 400-foot-radius of the in-river project area. The Hoffman House and surrounding grounds (96NR00984; 02740.000106) is located on the west side of North Water Street, adjacent to the former MGP site near its southeast corner, the location of the electric transition and substation area. This Greek Revival dwelling was constructed during the mid-19th century. The dwelling was listed in the National Register under Criteria A and C in 2007 and had been listed in the State Register in 1982.

The in-river work tasks will not cause direct effects to this property and it is highly unlikely that the project would cause indirect effects to the National Register-listed Hoffman House and grounds.

It is noted in CRIS that the National Register-listed Hudson River Sloop *Clearwater* (03NR05148) is moored within 400 feet to the south of the project footprint. This location will not be directly or indirectly affected by the proposed in-river project actions.

The CRIS search indicates that the entire project area is located within an Area of Archaeological Sensitivity. This is likely due to the location of the project along the east shore of the Hudson River and the presence of NYS Museum Sites within a one-mile-radius of the project area to the north (NYSM #3161) and south (NYSM #3141).

There are no previously identified terrestrial archaeological sites on the former MGP facility site or shipwrecks within the project footprint in the Hudson River depicted in CRIS. There are twelve previously identified terrestrial archaeological sites located within a one-mile-radius around the project area. Eleven of these sites are located in Dutchess County on the east side of the Hudson River; there is one previously identified site within the one-mile search radius in Ulster County on the west side of the Hudson River. Table 1 below provides site information from CRIS and the NYSM Site Files for these locations.

Table 1
Archaeological Resources Within One-Mile-Radius of Project Area
Historic Architectural Resources Within 400 feet of Project Area

SHPO/NRHP Site Number	Site Name	Site Type	Date / Time Period / Affiliation	Location / Address	National Register Status
Dutchess County Archaeological Resources					
02740.000847	Railroad Roundhouse Site	Historic Site: (intact remains below ground)	c.1870	Approximately 500 feet SSE of project site in MNR ROW, Poughkeepsie (Mascia 2000)	Eligible
02740.000045	Dump under Wheaton Park	Historic Site	Not given	Approximately 1,000 feet SE of project site in Wheaton Park, Poughkeepsie (Johnson 1976)	Undetermined
02714.000395 NYSM 11772	Rosenlund Gatehouse (Edward Beck Estate)	Historic Site	Pre-1867	Approximately .6 miles NE of project site; Currently owned by Marist College, 3399 North Road (Rte 9), Poughkeepsie	Eligible
02714.000389	Newbold/Fern Tor Estate	Historic Site	1861	Approximately .9 miles NNE of project site; Currently owned by Marist College, 3399 North Road (Rte 9), Poughkeepsie	Undetermined

**Table 1
Archaeological Resources Within One-Mile-Radius of Project Area
Historic Architectural Resources Within 400 feet of Project Area**

SHPO/NRHP Site Number	Site Name	Site Type	Date / Time Period / Affiliation	Location / Address	National Register Status
Dutchess County Archaeological Resources (cont'd)					
02714.000390	Woodcliff Lodge	Historic Site	Mid to late-19 th century	Approximately .9 miles NE of project site; Currently owned by Marist College, 3399 North Road (Rte 9), Poughkeepsie	Eligible
02740.000003	26 Garfield Place	Historic House Site	19 th century	Approximately .7 miles SE of project area, at 26 Garfield Place, Poughkeepsie (Puretz 1972)	Undetermined
02740.000867	59-63 Tulip Street	Historic Site: 3 intact foundations and associated cultural material	19 th and 20 th centuries	Approximately 0.7 miles SSE of project area at 59-63 Tulip Street, Poughkeepsie (Klinge 2004)	Undetermined
02740.000866	W.A. Southwick Tannery	Historic Tannery Site: foundation remains, a privy, and associated cultural material	1850-1890s	Approximately 0.6 miles south of project area, west of the intersection of Pine Street and Rinaldi Boulevard, Poughkeepsie (Klinge 2004)	Undetermined
NYSM 3162 ACP Duch No#	N/A	Traces of Occupation	Prehistoric	Museum Area polygon beginning approximately 1,200 feet north of the project site (Parker 1922)	Unevaluated
NYSM 3141 ACP Duch 9	Burials at Fox's Point	Burial Site: "six skeletons - all relics near these are early"; Camp Site	Prehistoric	Museum Area polygon beginning approximately 0.6 mile SSE of project site, east of railroad (Parker 1922)	Unevaluated

**Table 1
Archaeological Resources Within One-Mile-Radius of Project Area
Historic Architectural Resources Within 400 feet of Project Area**

SHPO/NRHP Site Number	Site Name	Site Type	Date / Time Period / Affiliation	Location / Address	National Register Status
Dutchess County Historic Architectural Resources					
96NR00984 02740.000106	Hoffman House	Domestic Building	Mid-19 th C	Adjacent to the MGP site to the southeast; west side of North Water Street, Poughkeepsie	Listed
90NR00370	Poughkeepsie Railroad Bridge	Railroad Bridge; Walkway Over the Hudson	1873-1888	Bridge spans the entire project site	Listed
03NR05148	Clearwater	Hudson River Sloop	1969; replica of mid-19 th century sloop	Moored on east bank of Hudson River within 400 feet to south of project site	Listed
Ulster County Archaeological Resources					
11107.000054	Dr. C. H. Roberts Estate On the Hudson	Historic?	Unknown	Approximately .7 miles SSW of the project site on the west side of Rte. 55 in Ulster County	Undetermined

SUMMARY OF CRIS SEARCH

It is anticipated that the in-river project actions will not create direct or indirect effects to the National Register-listed Walkway Over the Hudson bridge, the sloop Clearwater, or the National Register-listed historic Hoffman House located within the 400 foot search radius around the project site.

The in-river project actions will have no effect on terrestrial archaeological resources within the one mile search radius of the project location.

Results of 2017 Bathymetric Survey

The bathymetric survey employed multi-beam and side-scan sonar technologies to create a full-coverage map of the entire in-river work area, to include both riverbed elevation (contour) information and identification of submerged debris or other surface features that may interfere with dredging or capping.

Figure 4, the sonar mosaic with the utilities and targets displayed, depicts the results of the bathymetric survey. Figures 5-a through 5-d comprise the target report generated through the bathymetric survey. Two targets fall within proposed dredge areas, which are also depicted on Figure 4. Target 001 is located

within Prism 1, the northernmost of the proposed dredge areas. The object is described as 13.22 feet wide, 85.55 feet long, and 8.69 feet high. Target 001 is classified as a “possible wreck.” The proposed depth of dredging in Prism 1 is 1 foot, however, the dredging would impact and destroy this target. Target 006 is an “unknown object” located in Prism 25. It is described as 10.34 feet wide, 13.91 feet long, and 5.91 feet high. The proposed dredge depth for Prism 25 is 1 foot. The dredging would likely impact and destroy this object.

One additional target falls outside the proposed dredge areas, but will be affected by the in-river remediation actions. Target 003 is located within a utility capping area approximately 220 feet waterward of the existing bulkhead, along the route of the gas line crossing the Hudson River. It is described as an “unknown rectangular target” measuring 14.23 feet wide, 14.77 feet long, and 2.98 feet high and classified as debris. This target will not be impacted by dredging; it will be covered by concrete block mattresses to isolate the impacted sediment.

Target 005 lies within the benthic survey area, but is located outside the proposed boundaries of in-river remediation actions. Target 005 measures 1.04 feet wide, 41.14 feet long, and 0.13 feet high and is described as “power cables exposed on the river bottom.” They are located approximately 60 feet waterward of the existing bulkhead, and will not be affected by any proposed remediation action.

The remainder of the targets defined by the benthic survey will not be affected by the proposed remediation actions.

PHOTOGRAPHS



Photo 1 – Looking east across dredging area from river at northwest corner of former MGP and gas pipeline crossing warning sign. Note Walkway Over the Hudson Bridge crossing above



Photo 2 – Looking south along east bank of the Hudson River near the southwest corner of project site at electric cable crossing. Note Mid-Hudson Bridge in background



Photo 3 – Looking south from south edge of former MGP site; dredging will occur in discontinuous areas approximately 100 feet off the shoreline up to 500 feet southward

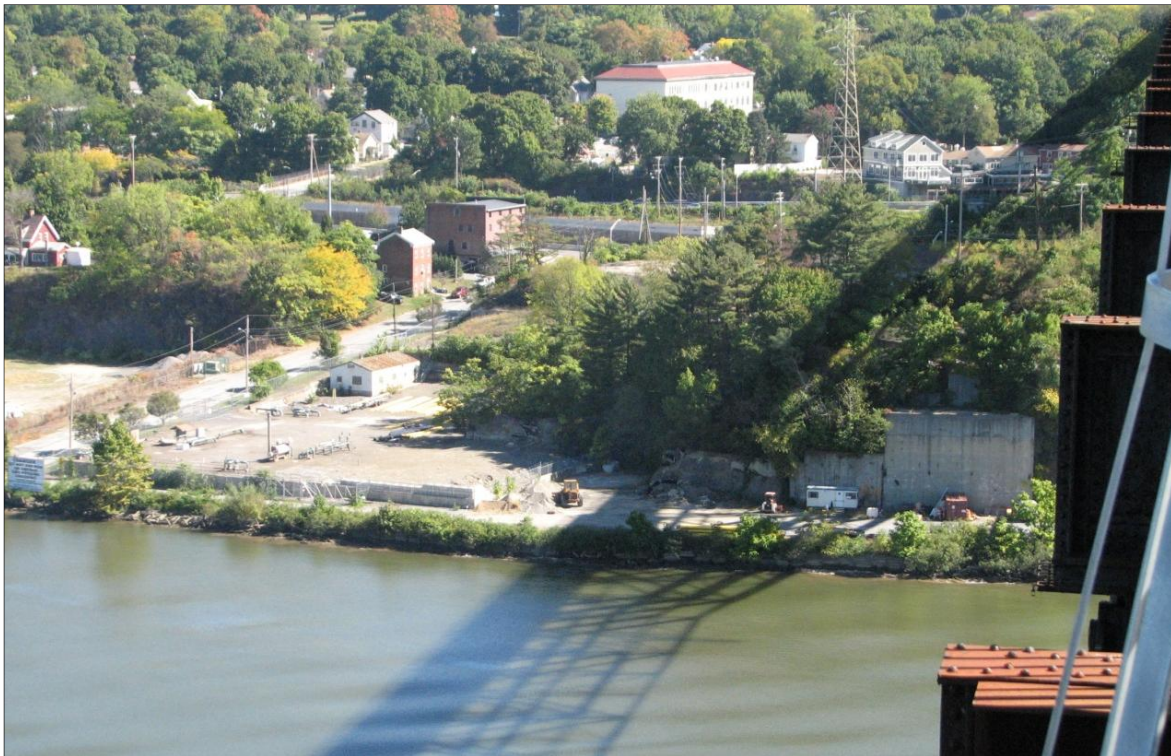

Photo 4 – Looking east from Walkway Over the Hudson; sideslope grading and capping will occur adjacent to the shoreline and dredging will occur in the foreground



Photo 5 – Looking north from Walkway Over the Hudson; sideslope grading and capping will occur in foreground along shoreline from Dutchess Avenue (midground) southward and dredging will occur approximately 100 feet off shoreline to a distance of 500 feet north of Dutchess Avenue



Photo 6 – Looking north from Walkway Over the Hudson showing where sideslope grading and capping will occur along shoreline



Photo 7 – Typical shoreline view of project area showing intact and deteriorated bulkhead; sideslope grading and capping will occur across this area



Photo 8 – Looking north along former MGP site shoreline; sideslope grading and capping will occur immediately along the shoreline and dredging and backfill work will occur approximately 100 feet offshore in the midground

FIGURES

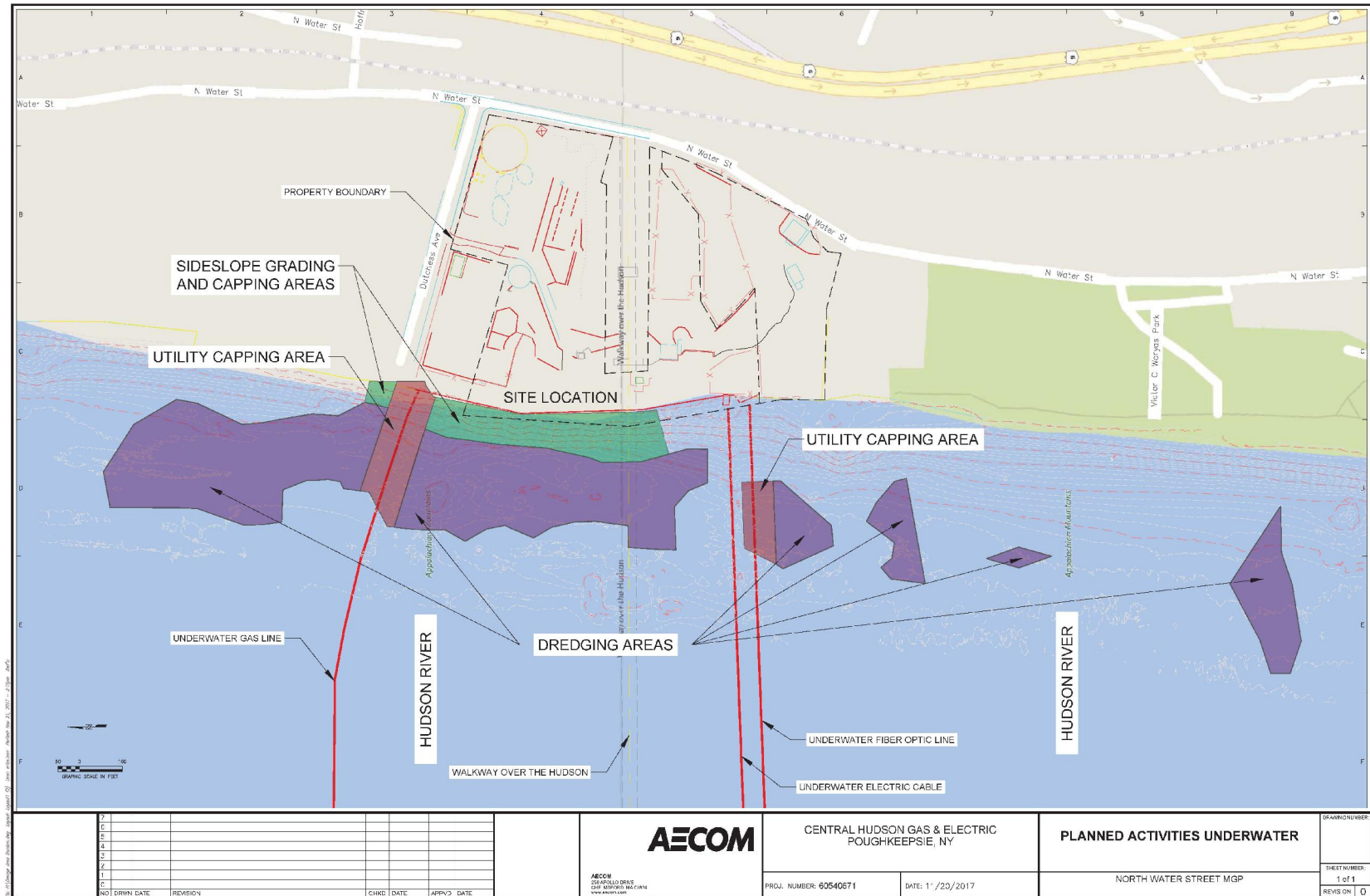

Figure 2 – In-river dredging, sideslope grading and capping, and utility capping areas.

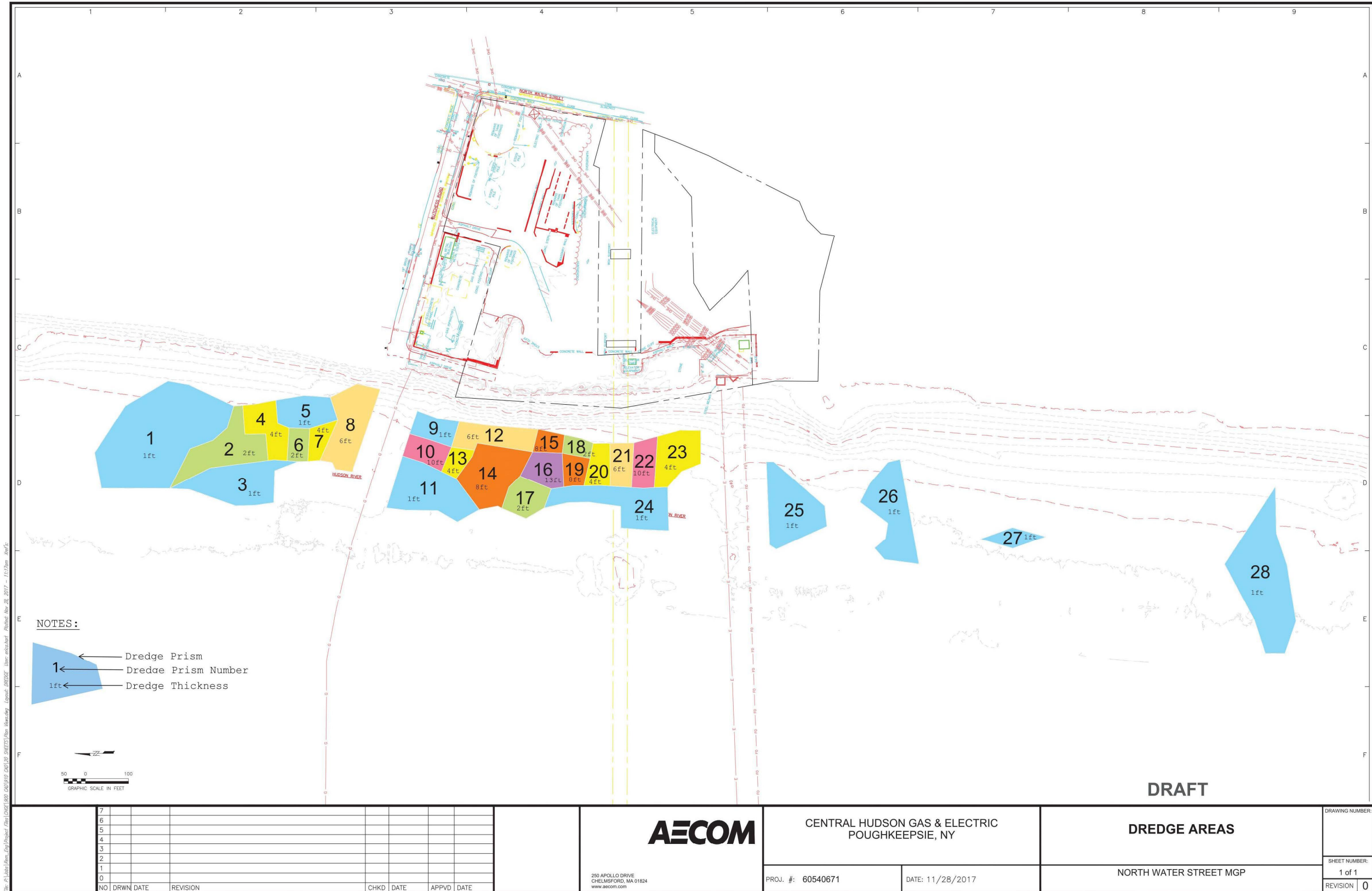

Figure 3 – Dredge prism identification numbers and proposed depths of dredging. Table 2 (following) details acreage and volumes by prism.

**Table 2
Breakdown of Approximate Dredge Areas, Volumes, and Thicknesses**

Dredge Prism	Prism Surface Area (sf)	Prism Surface Area (acre)	Dredge Volume (cy)	Deepest Dredge Design Thickness (ft)
1	52334	1.20	3045	1
2	16207	0.37	1557	2
3	17592	0.40	792	1
4	9519	0.22	1289	4
5	9513	0.22	1091	1
6	3791	0.09	454	2
7	3895	0.09	656	4
8	18164	0.42	3075	6
9	6363	0.15	1470	1
10	6147	0.14	1936	10
11	19758	0.45	4567	1
12	12440	0.29	2801	6
13	3278	0.08	1134	4
14	16916	0.39	5548	8
15	4199	0.10	1144	8
16	6565	0.15	3047	13
17	7558	0.17	1843	2
18	3113	0.07	702	2
19	3963	0.09	1415	8
20	5189	0.12	1061	4
21	6004	0.14	1274	6
22	6745	0.15	1780	10
23	12154	0.28	1847	4
24	18059	0.41	2714	1
25	18544	0.43	949	1
26	18435	0.42	697	1
27	3981	0.09	146	1
28	33968	0.78	1333	1
Total	344392	7.91	49369	

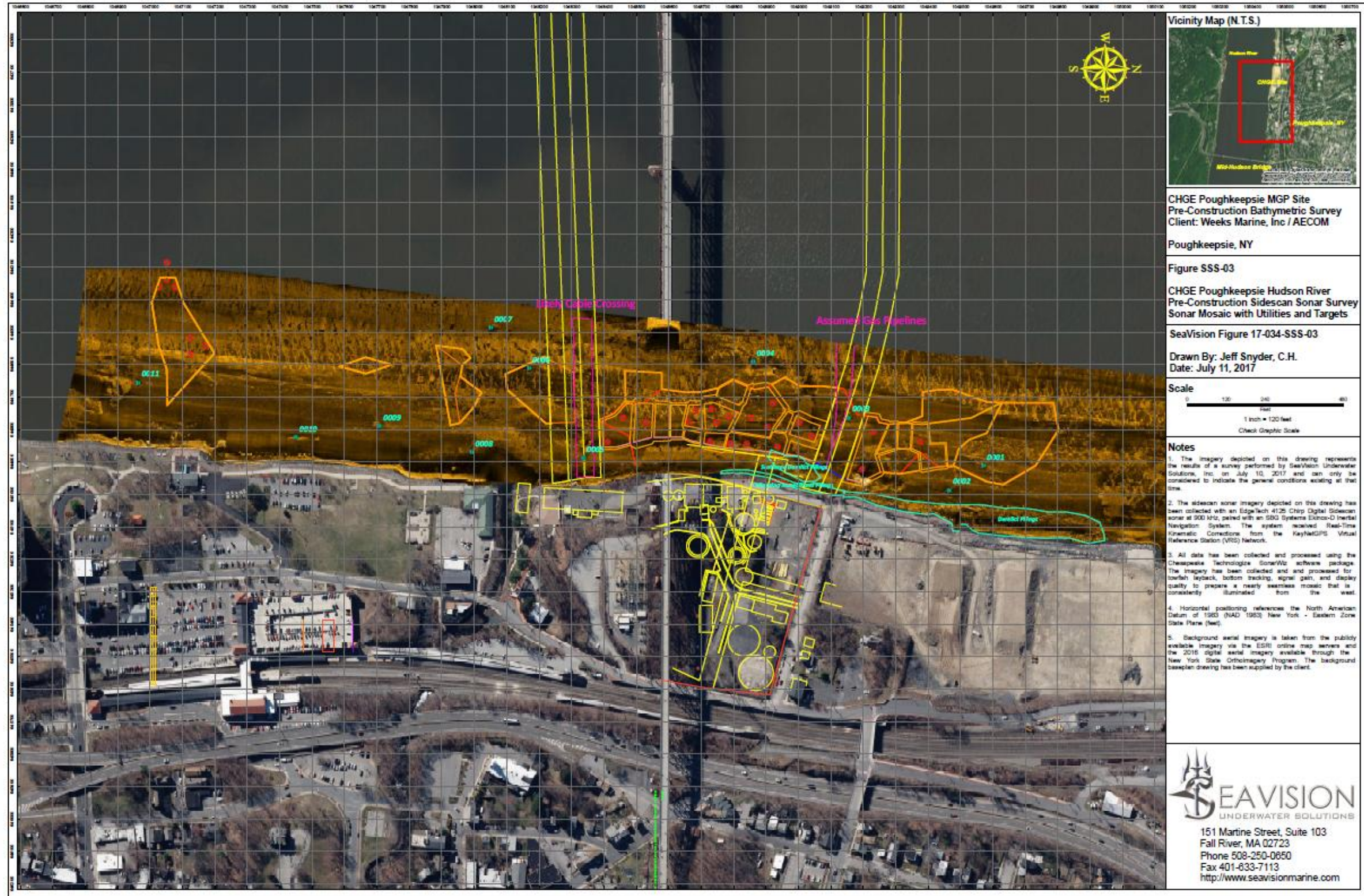

Figure 4 – Results of Bathymetric Survey; Sonar Mosaic with utilities and targets depicted.

CHGE Poughkeepsie SSS Target Report

Generated on 7/11/2017 11:01:50 PM

Target Image	Target Info	User Entered Info
	<p>CHGE-SSS-Target-0001</p> <ul style="list-style-type: none"> Click Position 41° 42.79758" N 073° 56.42178" W (WGS84) (X) 644911.19 (Y) 1049571.05 (Projected Coordinates) Map Projection: NY83-EF Water Depth: 13.58 US ft 	<p>Dimensions and attributes</p> <ul style="list-style-type: none"> Target Width: 13.22 US ft Target Height: 8.69 US ft Target Length: 85.35 US ft Target Shadow: 19.42 US ft Classification1: Possible wreck Description: Partially buried
	<p>CHGE-SSS-Target-0002</p> <ul style="list-style-type: none"> Click Position 41° 42.78025" N 073° 56.40532" W (WGS84) (X) 644986.77 (Y) 1049466.24 (Projected Coordinates) Map Projection: NY83-EF Water Depth: 13.47 US ft 	<p>Dimensions and attributes</p> <ul style="list-style-type: none"> Target Width: 2.89 US ft Target Height: 2.24 US ft Target Length: 34.36 US ft Target Shadow: 3.88 US ft Classification1: debris Description:

Figure 5-a

	<p>CHGE-SSS-Target-0003</p> <ul style="list-style-type: none"> Click Position 41° 42.72930" N 073° 56.45474" W (WGS84) (X) 644763.88 (Y) 1049155.38 (Projected Coordinates) Map Projection: NY83-EF Water Depth: 13.54 US ft 	<p>Dimensions and attributes</p> <ul style="list-style-type: none"> Target Width: 14.23 US ft Target Height: 2.98 US ft Target Length: 14.77 US ft Target Shadow: 12.93 US ft Classification1: Debris Description: Unknown rectangular target adjacent to gas pipeline.
	<p>CHGE-SSS-Target-0004</p> <ul style="list-style-type: none"> Click Position 41° 42.68097" N 073° 56.49319" W (WGS84) (X) 644590.83 (Y) 1048860.76 (Projected Coordinates) Map Projection: NY83-EF Water Depth: 11.76 US ft 	<p>Dimensions and attributes</p> <ul style="list-style-type: none"> Target Width: 1.64 US ft Target Height: 1.31 US ft Target Length: 86.74 US ft Target Shadow: 4.11 US ft Classification1: Unknown Description: Long straight object.
	<p>CHGE-SSS-Target-0005</p> <ul style="list-style-type: none"> Click Position 41° 42.59434" N 073° 56.42896" W (WGS84) (X) 644886.53 (Y) 1048336.58 (Projected Coordinates) Map Projection: NY83-EF Water Depth: 13.67 US ft 	<p>Dimensions and attributes</p> <ul style="list-style-type: none"> Target Width: 1.04 US ft Target Height: 0.13 US ft Target Length: 41.14 US ft Target Shadow: 0.26 US ft Classification1: cables Description: Power cables, exposed on river bottom.

Figure 5-b

	<p>CHGE-SSS-Target-0006</p> <ul style="list-style-type: none"> Click Position 41° 42.56710" N 073° 56.48926" W (WGS84) (X) 644613.24 (Y) 1048169.41 (Projected Coordinates) Map Projection: NY83-EF Water Depth: 12.41 US ft 	<p>Dimensions and attributes</p> <ul style="list-style-type: none"> Target Width: 10.34 US ft Target Height: 5.91 US ft Target Length: 13.91 US ft Target Shadow: 14.32 US ft Classification1: Unknown Description:
	<p>CHGE-SSS-Target-0007</p> <ul style="list-style-type: none"> Click Position 41° 42.54783" N 073° 56.51752" W (WGS84) (X) 644485.37 (Y) 1048051.55 (Projected Coordinates) Map Projection: NY83-EF Water Depth: 11.65 US ft 	<p>Dimensions and attributes</p> <ul style="list-style-type: none"> Target Width: 9.72 US ft Target Height: 6.39 US ft Target Length: 23.12 US ft Target Shadow: 27.36 US ft Classification1: debris Description: Unknown object.
	<p>CHGE-SSS-Target-0008</p> <ul style="list-style-type: none"> Click Position 41° 42.53767" N 073° 56.43312" W (WGS84) (X) 644869.82 (Y) 1047992.32 (Projected Coordinates) Map Projection: NY83-EF Water Depth: 12.06 US ft 	<p>Dimensions and attributes</p> <ul style="list-style-type: none"> Target Width: 6.41 US ft Target Height: 3.03 US ft Target Length: 14.59 US ft Target Shadow: 8.99 US ft Classification1: car Description:

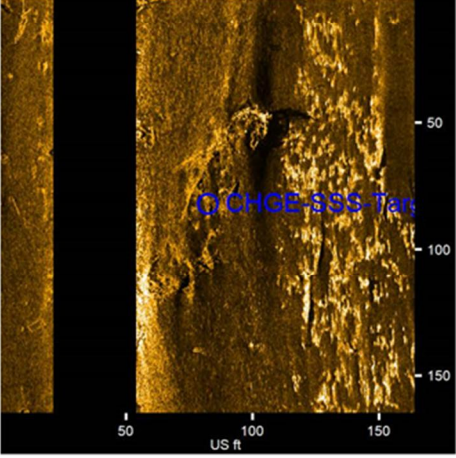
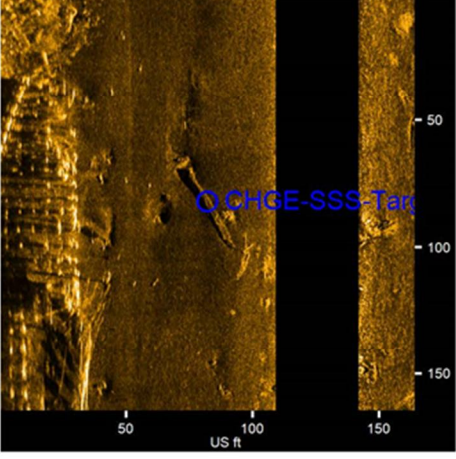
Figure 5-c

	<p>CHGE-SSS-Target-0009</p> <ul style="list-style-type: none"> Click Position 41° 42.49104" N 073° 56.45088" W (WGS84) (X) 644790.88 (Y) 1047708.68 (Projected Coordinates) Map Projection: NY83-EF Water Depth: 12.01 US ft 	<p>Dimensions and attributes</p> <ul style="list-style-type: none"> Target Width: 8.17 US ft Target Height: 2.83 US ft Target Length: 27.81 US ft Target Shadow: 9.52 US ft Classification1: debris Description: Unknown rectangular object.
	<p>CHGE-SSS-Target-0010</p> <ul style="list-style-type: none"> Click Position 41° 42.44842" N 073° 56.44380" W (WGS84) (X) 644824.75 (Y) 1047450.02 (Projected Coordinates) Map Projection: NY83-EF Water Depth: 12.12 US ft 	<p>Dimensions and attributes</p> <ul style="list-style-type: none"> Target Width: 4.93 US ft Target Height: 2.47 US ft Target Length: 12.79 US ft Target Shadow: 8.09 US ft Classification1: car Description:
	<p>CHGE-SSS-Target-0011</p> <ul style="list-style-type: none"> Click Position 41° 42.36850" N 073° 56.48161" W (WGS84) (X) 644655.87 (Y) 1046963.59 (Projected Coordinates) Map Projection: NY83-EF Water Depth: 11.95 US ft 	<p>Dimensions and attributes</p> <ul style="list-style-type: none"> Target Width: 5.51 US ft Target Height: 4.13 US ft Target Length: 16.28 US ft Target Shadow: 18.81 US ft Classification1: boat Description:

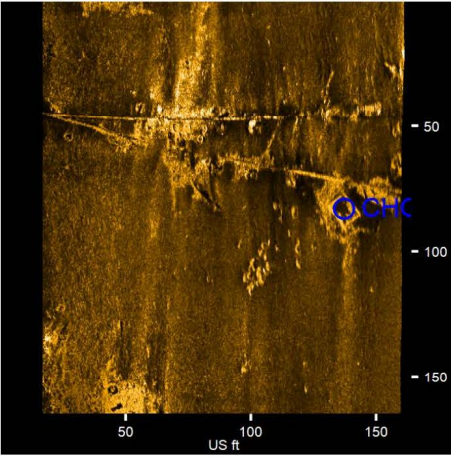
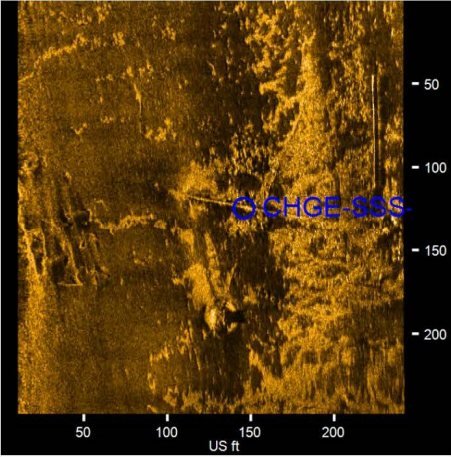
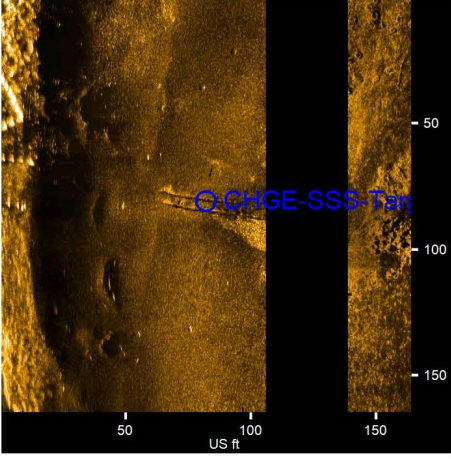
Figure 5-d

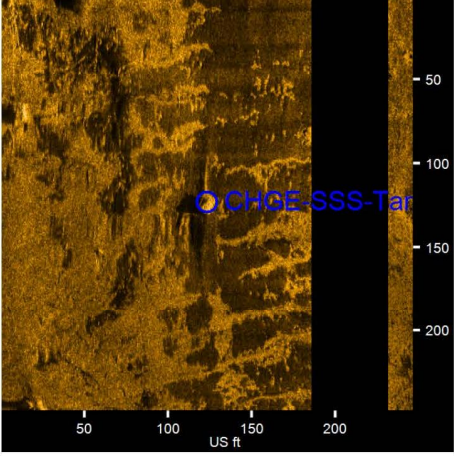
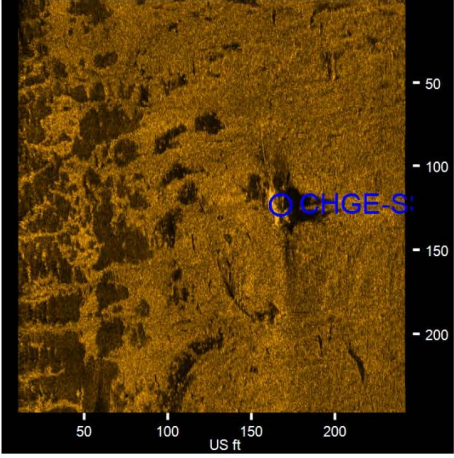
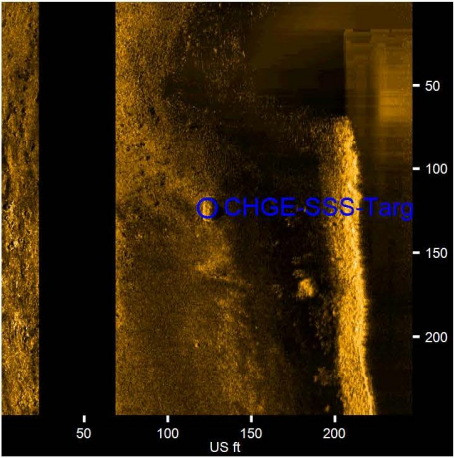

PART 1 – APPLICANT COMPLETES

APPLICANT INFORMATION

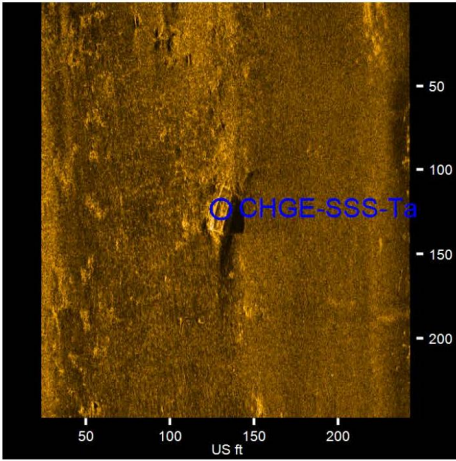
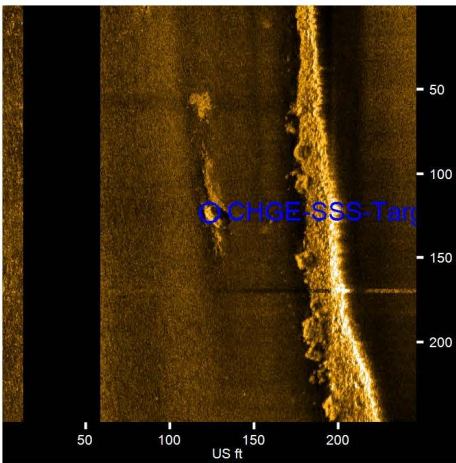
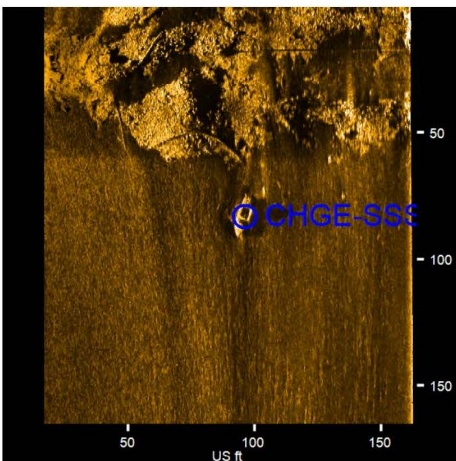
1. Applicant Name:

2. Applicant Address:

PROJECT INFORMATION

3. Project/Facility Name:

4. Project/Facility Location:

5. Is the proposed project adjacent to, or does it contain a building or structure listed in the State or National Register of Historic Places? Yes No

6. Are there any buildings or structures 50 years old or older adjacent to or within the proposed project area? Yes No

If the answer to question 5 and /or 6 is yes, provide the following information for each building and structure (use attachments if necessary):

a. Name of structure:

b. Location:

c. Type of structure (ex. house, outbuilding, barn, bridge, dam, ruins):

d. Approximate age or date of construction:

7. Might the proposed project have any impact (physical/visual) upon any buildings or structures listed in the State or National Register of Historic Places or 50 years old or older? Yes No

If yes, describe briefly (use attachments if necessary):

8. Provide photographs of every building and structure that may be impacted by the project as described in number 7, on the opposite side of this page. The following standards are recommended:

- Minimum of 2 photographs
- Photographs must be 3.5" x 5" in size or larger
- Photos must be clear and focused
- Digital photographs must be printed on photo paper and be produced at a printer setting of a minimum of 600 dpi
- Clearly label photos so it is obvious what is being illustrated; key photos to map or plan, if possible
- Photo 1: show both the entire front and side of the structure in a single shot from as close to the building as possible. Be sure the structure is not partially or fully blocked by trees or other obstructions
- Photo 2: show relationship of building or structure to roadway or surroundings

9. Has the land within the proposed project area been previously disturbed or altered (excavated, landscaped, filled, utilities installed)? Yes No

If yes, describe briefly, including depth of disturbance (use attachments if necessary):

10. Approximate percentage of proposed project area with slopes:

- 0-10% %
- 10-15% %
- 15% or greater %

11. Approximate percentage of proposed project site with the following drainage characteristics:

- Well drained %
- Moderately well drained %
- Poorly drained %

Prepared By (Print or type name):

Signature:

Date:

**PART 2 – DEPARTMENT OF ENVIRONMENTAL CONSERVATION
(DEC) COMPLETES**

APPLICANT/PROJECT INFORMATION

- 1. Applicant Name:
- 2. Project/Facility Name:
- 3. DEC Number:

BUILDINGS AND STRUCTURES

4. Might the proposed project have any impact (physical/visual) upon any buildings or structures listed in the State or National Register of Historic Places or 50 years old or older? Yes No

If yes, DEC must consult with the Office of Parks, Recreation and Historic Preservation (OPRHP). DEC must request a determination of eligibility for the State Register of Historic Places and/or comments regarding project impact. Include information supplied by the applicant in response to questions 5, 6, 7 and 8 of **Part 1** of this form.

ARCHAEOLOGICAL SITES

5. Does the proposed project area coincide with a circle, square or stippled area on OPRHP's Statewide Archaeological Inventory Map? Yes No

6. Is the proposed project area outside of a circle or square, but one for which information has been provided (ex: documented reports of known sites) that suggests the area is archaeologically sensitive? Yes No

If yes, what is the nature and source of information?

7. Is the proposed project area apparently undisturbed? Yes No

8. Will the proposed action include a physical disturbance of the project area? Yes No

9. Is the slope in the area characteristically less than 15% (unless on limestone/flint escarpments)? Yes No

Attachment 7

Letter of No Objection From NYSOGS



**Office of
General Services**

ANDREW M. CUOMO
Governor

ROANN M. DESTITO
Commissioner

January 10, 2018

Ms. Reeti Doshi
Environmental Engineer
AECOM
125 Broad Street
15th Floor
New York, NY 10004

Dear Ms. Doshi:

**RE: CH-Water St.- Poughkeepsie MGP
Brownfield Cleanup Program
Site No. C314070**

This is response to a recent inquiry from James Mansky of your office, regarding whether the dredging of sediment associated with the above-noted project would require a License for Removal of Materials from Lands Underwater or any other permit from our agency. We have reviewed the Decision Document prepared by the NYS Department of Environmental Conservation, Division of Environmental Remediation, dated March 2016, outlining the cleanup remedy, and have no objection to the project, as described. No further authorization will be required from our agency.

Thank you for the opportunity to review and comment on this project. If you have any questions regarding this matter, please call me directly at (518) 474-2195.

Sincerely,

Bethany M. Wiczorek
Real Estate Officer 1, Bureau of Land Management
Real Estate Services

Attachment 8

New York Natural Heritage Program Review

NEW YORK STATE DEPARTMENT OF ENVIRONMENTAL CONSERVATION

Division of Fish and Wildlife, New York Natural Heritage Program

625 Broadway, Fifth Floor, Albany, NY 12233-4757

P: (518) 402-8935 | F: (518) 402-8925

www.dec.ny.gov

November 21, 2017

James Mansky
AECOM
125 Broad Street
New York, NY 10004

Re: Central Hudson Gas & Electric Corporation sediment dredging in Hudson River
County: Dutchess Town/City: City Of Poughkeepsie

Dear Mr. Mansky:

In response to your recent request, we have reviewed the New York Natural Heritage Program database with respect to the above project.

Enclosed is a report of rare or state-listed animals and plants, and significant natural communities that our database indicates occur within one mile of the project site.

For most sites, comprehensive field surveys have not been conducted; the enclosed report only includes records from our database. We cannot provide a definitive statement as to the presence or absence of all rare or state-listed species or significant natural communities. Depending on the nature of the project and the conditions at the project site, further information from on-site surveys or other sources may be required to fully assess impacts on biological resources.

Our database is continually growing as records are added and updated. If this proposed project is still under development one year from now, we recommend that you contact us again so that we may update this response with the most current information.

The presence of the plants and animals identified in the enclosed report may result in this project requiring additional review or permit conditions. For further guidance, and for information regarding other permits that may be required under state law for regulated areas or activities (e.g., regulated wetlands), please contact the NYS DEC Region 3 Office, Division of Environmental Permits, at dep.r3@dec.ny.gov, (845) 256-3054.

Sincerely,



Nicholas Conrad
Information Resources Coordinator
New York Natural Heritage Program



The following state-listed animals have been documented at or within one mile of the project site.

The following list includes animals that are listed by NYS as Endangered, Threatened, or Special Concern; and/or that are federally listed or are candidates for federal listing.

For information about any permit considerations for the project, please contact the Permits staff at the NYSDEC Region 3 Office at dep.r3@dec.ny.gov, (845) 256-3054. For information about potential impacts of the project on these species, and how to avoid, minimize, or mitigate any impacts, contact: for sturgeon: Hudson River Fisheries Unit, HudsonRiverFish@dec.ny.gov, 845-256-3071. for peregrine falcon: Region 3 Wildlife staff, Wildlife.R3@dec.ny.gov, (845) 256-3098.

The following species have been documented in the Hudson River.

<i>COMMON NAME</i>	<i>SCIENTIFIC NAME</i>	<i>NY STATE LISTING</i>	<i>FEDERAL LISTING</i>	
Shortnose Sturgeon	<i>Acipenser brevirostrum</i>	Endangered	Endangered	1091
Atlantic Sturgeon	<i>Acipenser oxyrinchus</i>	No Open Season	Endangered	11464

The following species has been documented nesting about .5 mile from the project site.

Peregrine Falcon <i>Nesting</i>	<i>Falco peregrinus</i>	Endangered		2203
---	-------------------------	------------	--	------

This report only includes records from the NY Natural Heritage database.

If any rare plants or animals are documented during site visits, we request that information on the observations be provided to the New York Natural Heritage Program so that we may update our database.

Information about many of the listed animals in New York, including habitat, biology, identification, conservation, and management, are available online in Natural Heritage's Conservation Guides at www.guides.nynhp.org, and from NYSDEC at www.dec.ny.gov/animals/7494.html.



The following rare plants have been documented within one mile of the project site.

We recommend that potential onsite and offsite impacts of the proposed project on these species be addressed as part of any environmental assessment or review conducted as part of the planning, permitting and approval process, such as reviews conducted under SEQ. Field surveys of the project site may be necessary to determine the status of a species at the site, particularly for sites that are currently undeveloped and may still contain suitable habitat. Final requirements of the project to avoid, minimize, or mitigate potential impacts are determined by the lead permitting agency or the government body approving the project.

The following plants are listed as Endangered or Threatened by New York State, and so are a vulnerable natural resource of conservation concern.

<i>COMMON NAME</i>	<i>SCIENTIFIC NAME</i>	<i>NY STATE LISTING</i>	<i>HERITAGE CONSERVATION STATUS</i>
Davis' Sedge	<i>Carex davisii</i>	Threatened	Imperiled in NYS
Mid-Hudson Woods, Town of Lloyd, Ulster County, 2011-06-21: The plants are growing along a trail within a mid-successional hardwood forest.			
Virginia Snakeroot	<i>Endodeca serpentaria</i>	Threatened	Imperiled in NYS
Mid-Hudson Woods, Town of Lloyd, Ulster County, 2011-09-09: This is a small talus slope up to 10 meters high and 40 meters long with a southeast aspect and moderate slope. The slope is apparently fairly stable. There is oak-hickory type vegetation with a diverse herb layer.			

13725

12438

This report only includes records from the NY Natural Heritage database. For most sites, comprehensive field surveys have not been conducted, and we cannot provide a definitive statement as to the presence or absence of all rare or state-listed species. Depending on the nature of the project and the conditions at the project site, further information from on-site surveys or other sources may be required to fully assess impacts on biological resources.

If any rare plants or animals are documented during site visits, we request that information on the observations be provided to the New York Natural Heritage Program so that we may update our database.

Information about many of the rare animals and plants in New York, including habitat, biology, identification, conservation, and management, are available online in Natural Heritage's Conservation Guides at www.guides.nynhp.org, from NatureServe Explorer at www.natureserve.org/explorer, and from USDA's Plants Database at <http://plants.usda.gov/index.html> (for plants).

Information about many of the natural community types in New York, including identification, dominant and characteristic vegetation, distribution, conservation, and management, is available online in Natural Heritage's Conservation Guides at www.guides.nynhp.org. For descriptions of all community types, go to www.dec.ny.gov/animals/97703.html for Ecological Communities of New York State.

November 10, 2017

New York Natural Heritage Program
New York State Department of Environmental
Conservation
625 Broadway, 5th Floor
Albany, NY 12233-4757

**SUBJECT: CENTRAL HUDSON GAS & ELECTRIC CORP.
DREDGING, POUGHKEEPSIE, NEW YORK**

Dear Sir or Madam:

In accordance with a New York State Department of Environmental Conservation *Decision Document* (March 2016), Central Hudson Gas & Electric Corporation (CHGE) proposes to dredge sediment in the Hudson River adjacent to their facility in Poughkeepsie, Dutchess County, New York. The dredging would remove sediments impacted by the operation of a former manufactured gas plant facility on the CHGE property.

AECOM, on behalf of CHGE, is requesting information regarding the occurrence of all state-listed species including rare, threatened and endangered species, as well as any other ecological resources or species of special concern within 1 mile of the study area, which is depicted on the attached USGS Quadrangle.

If you have any questions or need additional information, please contact Mr. James Mansky at (212) 377-8736 or james.mansky@aecom.com.

Thank you for your assistance.

Sincerely,

AECOM



James Mansky
Principal Ecologist

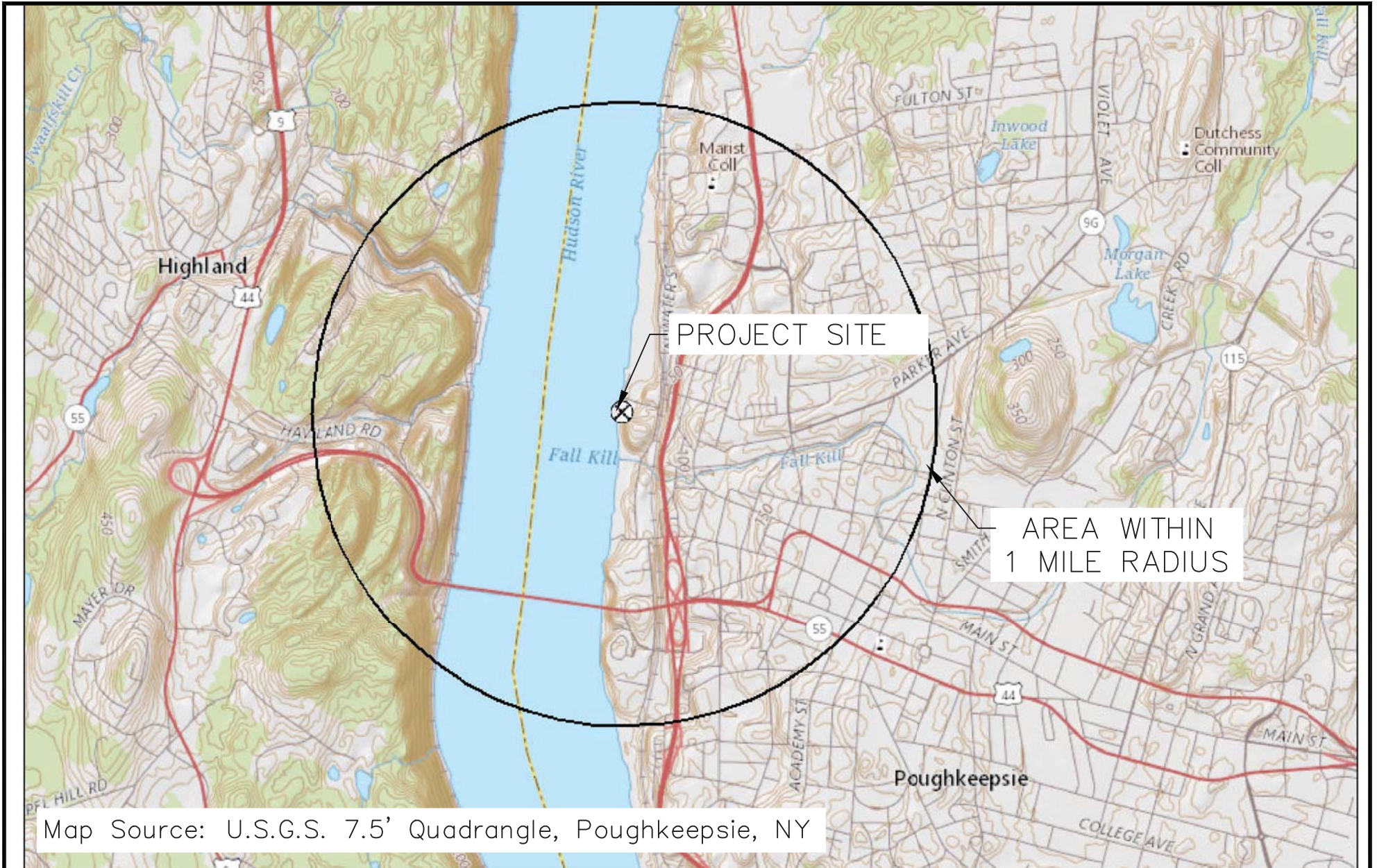

Map Source: U.S.G.S. 7.5' Quadrangle, Poughkeepsie, NY

	CENTRAL HUDSON GAS & ELECTRIC POUGHKEEPSIE, NY				SITE LOCATION MAP				DRAWING NUMBER:
	PROJ. NUMBER: 60540671		DATE: 11/07/2017		NORTH WATER STREET MGP				SHEET NUMBER:
1									
0								REVISION	
NO	DRWN	DATE	REVISION	CHKD	DATE	APPVD	DATE	REVISION	0

Attachment 9

National Marine Fisheries Services Review



UNITED STATES DEPARTMENT OF COMMERCE
National Oceanic and Atmospheric Administration
NATIONAL MARINE FISHERIES SERVICE
GREATER ATLANTIC REGIONAL FISHERIES OFFICE
55 Great Republic Drive
Gloucester, MA 01930-2276

NOV 16 2017

James Mansky
AECOM
125 Broad Street
New York, NY 10004

**Re: Central Hudson Gas & Electric Corp.
Dredging, Poughkeepsie, New York**

Dear Mr. Mansky:

We received your letter on November 13, 2017, regarding the proposed dredging project in the Hudson River adjacent to Poughkeepsie, New York. The dredging would remove sediments impacted by the operation of a former manufactured gas plant facility on the CHGE property. In your letter, you requested information regarding the presence of federally listed threatened and endangered species within one mile of the study area that may be affected by the project. We offer the following comments.

Endangered Species Act

Atlantic Sturgeon

Atlantic sturgeon are present in the waters of the Hudson River and its adjacent bays and tributaries. The New York Bight, Chesapeake Bay, Carolina, and South Atlantic Distinct Population Segments (DPSs) of Atlantic sturgeon are endangered; the Gulf of Maine DPS is threatened. Transient individuals originating from any of these DPS could occur in the proposed project area to opportunistically forage. The project area is a known spawning site for adults. Depending on the time of year that the project will be occurring, all life stages of Atlantic sturgeon could be present in the project area.

On August 17, 2017, NOAA Fisheries published a final rule designating critical habitat for the Gulf of Maine, New York Bight, Chesapeake Bay, Carolina, and South Atlantic DPSs of Atlantic sturgeon (82 FR 39160). The effective date of the rule was September 18, 2017. The action you have proposed will occur in an area that is designated as critical habitat.

Shortnose Sturgeon

Shortnose sturgeon are present in the waters of the Hudson River and could occur in their adjacent bays and tributaries. Shortnose sturgeon are listed as endangered throughout their range. The project area is a known overwintering site for adults. Transient larval, juvenile, and adult individuals could occur in the proposed project area to opportunistically forage.



As project details develop, we recommend you consider the following effects of the project on Atlantic and shortnose sturgeon:

- For any impacts to habitat or conditions that temporarily render affected water bodies unsuitable for the above-mentioned species, consider the use of timing restrictions for in-water work.
- For activities that increase levels of suspended sediment, consider the use of silt management and/or soil erosion best practices (i.e., silt curtains and/or cofferdams).

The lead federal action agency for this action will be responsible for determining whether the proposed action may affect listed species under the ESA and critical habitat for Atlantic sturgeon. If the agency determines that the proposed action may affect a listed species and/or Atlantic sturgeon critical habitat, they should submit their determination of effects, along with justification and a request for concurrence to the attention of the Section 7 Coordinator, NMFS, Greater Atlantic Regional Fisheries Office, Protected Resources Division, 55 Great Republic Drive, Gloucester, MA 01930 or nmfs.gar.esa.section7@noaa.gov. Please be aware that we have recently provided on our website guidance and tools to assist action agencies with their description of the action and analysis of effects to support their determination. See - <http://www.greateratlantic.fisheries.noaa.gov/section7>. After receiving a complete, accurate comprehensive request for consultation, in accordance to the guidance and instructions on our website, we would then be able to conduct a consultation under section 7 of the ESA. Should project plans change or new information become available that changes the basis for this determination, further coordination should be pursued. If you have any questions regarding these comments, please contact Edith Carson (978-282-8490; Edith.Carson@noaa.gov).

Fish and Wildlife Coordination Act

The Hudson River provides habitat for a wide variety of NOAA resources including resident, migratory and forage fish species such as weakfish, tautog, American eel, winter flounder, summer flounder, Atlantic tomcod, bluefish and many others. The river is used as a migratory corridor and for spawning, nursery and forage habitat for diadromous species including American shad, alewife and blueback herring, striped bass and American eel. Depending upon the nature and extent of the work proposed, seasonal in-water work restrictions or other conditions may be required to avoid, minimize or mitigate for any adverse effects to aquatic resources and their habitats. Compensatory mitigation may also be necessary to offset habitat loss or degradation.

Magnuson-Stevens Fishery Conservation and Management Act - Essential Fish Habitat

Essential Fish Habitat (EFH) has been designated within the project area for federally managed fish species. The Magnuson-Stevens Fishery Conservation and Management Act (MSA) requires federal agencies to consult with us on any action or proposed action authorized, funded, or undertaken by the agency that may adversely affect EFH identified under the MSA. The EFH regulations, 50 CFR Section 600.920, outline that consultation procedure and require the preparation of an EFH assessment by the action agency, or its designated non-federal representative. Based upon the information provided, further EFH consultation by the federal action agency will be required for this project. For a listing of EFH and further information, please go to our website at: <http://www.greateratlantic.fisheries.noaa.gov/habitat/index.html>. If

you wish to discuss this further, please contact Ursula Howson at 732-872-3116 or Ursula.Howson@noaa.gov.

Sincerely,



Mark Murray-Brown
Section 7 Coordinator
for Protected Resources Division

EC: Carson, Howson

File Code: H:\Section 7 Team\Section 7\Non-Fisheries\Tech Assist_States_Private Firms\2017\AECOM CHGE Dredge Hudson

November 10, 2017

Regional Administrator for Protected Resources
National Marine Fisheries Service
Northeast Regional Office
55 Great Republic Drive
Gloucester, Massachusetts 01930-2276

**SUBJECT: CENTRAL HUDSON GAS & ELECTRIC CORP.
DREDGING, POUGHKEEPSIE, NEW YORK**

Dear Sir or Madam:

In accordance with a New York State Department of Environmental Conservation Decision Document (March 2016), Central Hudson Gas & Electric Corporation (CHGE) proposes to dredge sediment in the Hudson River adjacent to their facility in Poughkeepsie, Dutchess County, New York. The dredging would remove sediments impacted by the operation of a former manufactured gas plant facility on the CHGE property.

AECOM, on behalf of CHGE, is requesting information under Section 7 of the Endangered Species Act (16 USC § 1536), the Marine Mammal Protection Act (16 USC §§ 1361 et seq.) and the Magnuson-Stevens Fishery Conservation and Management Act (16 USC §§ 1856 et seq.), for the proposed project regarding the presence of federally-listed threatened and endangered species and managed species within 1 mile of the study area or that may be affected by the project.

If you have any questions or need additional information, please contact Mr. James Mansky at (212) 377-8736 or james.mansky@aecom.com.

Thank you for your assistance.

Sincerely,

AECOM

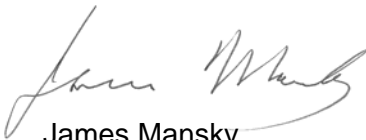

James Mansky
Principal Ecologist

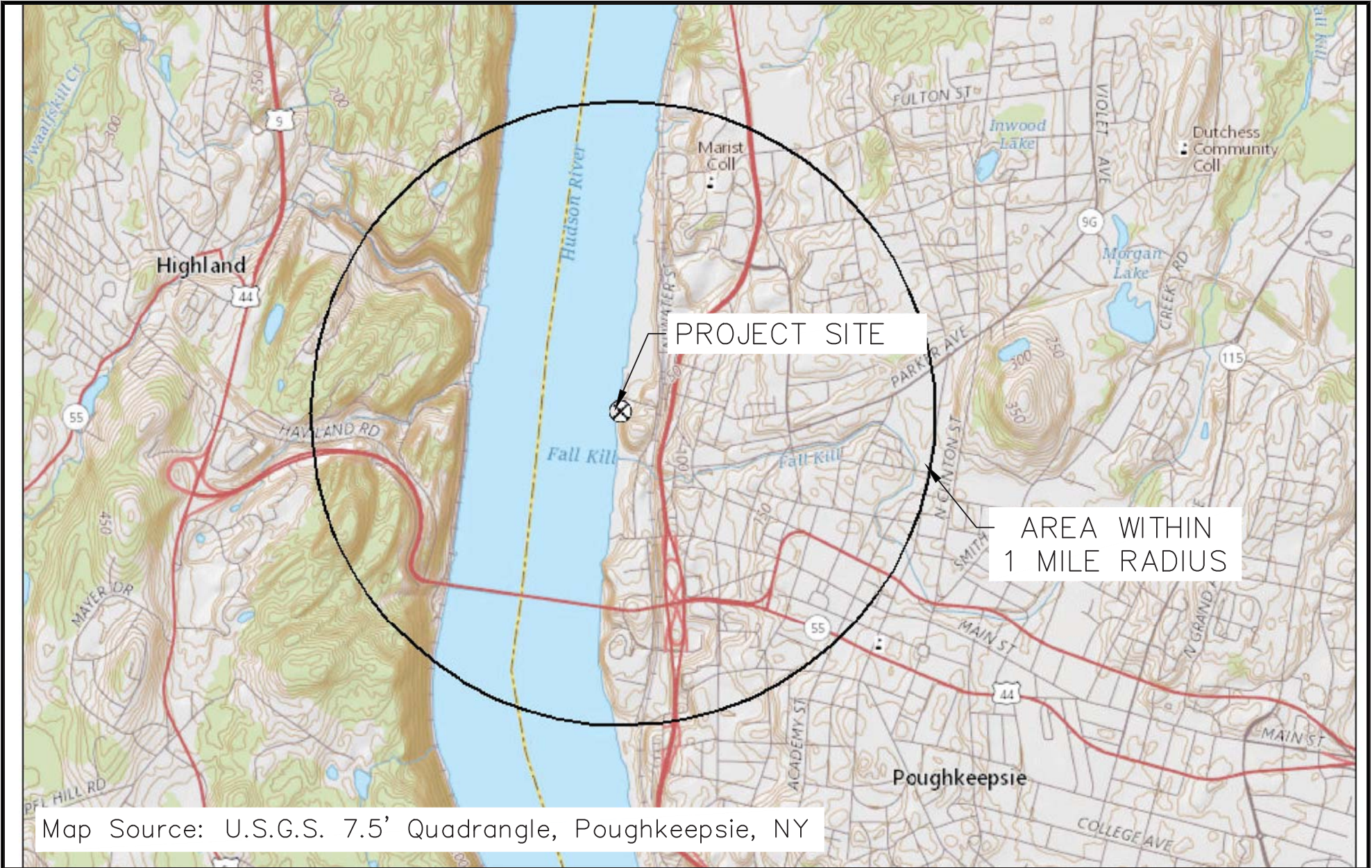

Map Source: U.S.G.S. 7.5' Quadrangle, Poughkeepsie, NY

<p>AECOM 250 APOLLO DRIVE CHELMSFORD, MA 01824 www.aecom.com</p>	CENTRAL HUDSON GAS & ELECTRIC POUGHKEEPSIE, NY				SITE LOCATION MAP				DRAWING NUMBER:	
	PROJ. NUMBER: 60540671		DATE: 11/07/2017		NORTH WATER STREET MGP				SHEET NUMBER:	
1									1 of 1	
0									REVISION 0	
NO	DRWN	DATE	REVISION	CHKD	DATE	APPVD	DATE			

Attachment 10

U. S. Fish and Wildlife Services Review



United States Department of the Interior



FISH AND WILDLIFE SERVICE

New York Ecological Services Field Office

3817 Luker Road

Cortland, NY 13045-9349

Phone: (607) 753-9334 Fax: (607) 753-9699

<http://www.fws.gov/northeast/nyfo/es/section7.htm>

In Reply Refer To:

November 07, 2017

Consultation Code: 05E1NY00-2018-SLI-0328

Event Code: 05E1NY00-2018-E-00985

Project Name: Central Hudson Gas & Electric Corp.

Subject: List of threatened and endangered species that may occur in your proposed project location, and/or may be affected by your proposed project

To Whom It May Concern:

The enclosed species list identifies threatened, endangered, proposed and candidate species, as well as proposed and final designated critical habitat, that may occur within the boundary of your proposed project and/or may be affected by your proposed project. The species list fulfills the requirements of the U.S. Fish and Wildlife Service (Service) under section 7(c) of the Endangered Species Act (ESA) of 1973, as amended (16 U.S.C. 1531 et seq.). This list can also be used to determine whether listed species may be present for projects without federal agency involvement. New information based on updated surveys, changes in the abundance and distribution of species, changed habitat conditions, or other factors could change this list.

Please feel free to contact us if you need more current information or assistance regarding the potential impacts to federally proposed, listed, and candidate species and federally designated and proposed critical habitat. Please note that under 50 CFR 402.12(e) of the regulations implementing section 7 of the ESA, the accuracy of this species list should be verified after 90 days. This verification can be completed formally or informally as desired. The Service recommends that verification be completed by visiting the ECOS-IPaC site at regular intervals during project planning and implementation for updates to species lists and information. An updated list may be requested through the ECOS-IPaC system by completing the same process used to receive the enclosed list. If listed, proposed, or candidate species were identified as potentially occurring in the project area, coordination with our office is encouraged. Information on the steps involved with assessing potential impacts from projects can be found at: <http://www.fws.gov/northeast/nyfo/es/section7.htm>

Please be aware that bald and golden eagles are protected under the Bald and Golden Eagle Protection Act (16 U.S.C. 668 et seq.), and projects affecting these species may require development of an eagle conservation plan (

http://www.fws.gov/windenergy/eagle_guidance.html). Additionally, wind energy projects should follow the Services wind energy guidelines (<http://www.fws.gov/windenergy/>) for minimizing impacts to migratory birds and bats.

Guidance for minimizing impacts to migratory birds for projects including communications towers (e.g., cellular, digital television, radio, and emergency broadcast) can be found at: <http://www.fws.gov/migratorybirds/CurrentBirdIssues/Hazards/towers/towers.htm>; <http://www.towerkill.com>; and <http://www.fws.gov/migratorybirds/CurrentBirdIssues/Hazards/towers/comtow.html>.

We appreciate your concern for threatened and endangered species. The Service encourages Federal agencies to include conservation of threatened and endangered species into their project planning to further the purposes of the ESA. Please include the Consultation Tracking Number in the header of this letter with any request for consultation or correspondence about your project that you submit to our office.

Attachment(s):

- Official Species List

Official Species List

This list is provided pursuant to Section 7 of the Endangered Species Act, and fulfills the requirement for Federal agencies to "request of the Secretary of the Interior information whether any species which is listed or proposed to be listed may be present in the area of a proposed action".

This species list is provided by:

New York Ecological Services Field Office
3817 Luker Road
Cortland, NY 13045-9349
(607) 753-9334

Project Summary

Consultation Code: 05E1NY00-2018-SLI-0328

Event Code: 05E1NY00-2018-E-00985

Project Name: Central Hudson Gas & Electric Corp.

Project Type: DREDGE / EXCAVATION

Project Description: Excavation and dredging of coal tar contaminated soil and sediment from former gas manufacturing facility on the CHGE Water Street site.

Project Location:

Approximate location of the project can be viewed in Google Maps:

<https://www.google.com/maps/place/41.71185408686924N73.9401939467364W>

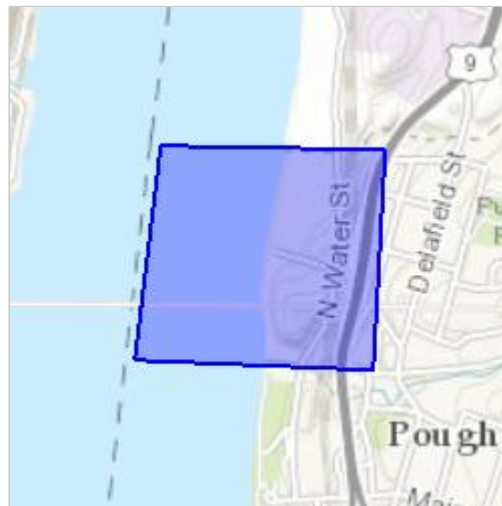

Counties: Dutchess, NY

Endangered Species Act Species

There is a total of 3 threatened, endangered, or candidate species on this species list. Species on this list should be considered in an effects analysis for your project and could include species that exist in another geographic area. For example, certain fish may appear on the species list because a project could affect downstream species. See the "Critical habitats" section below for those critical habitats that lie wholly or partially within your project area under this office's jurisdiction. Please contact the designated FWS office if you have questions.

Mammals

NAME	STATUS
Indiana Bat <i>Myotis sodalis</i> There is final critical habitat for this species. Your location is outside the critical habitat. Species profile: https://ecos.fws.gov/ecp/species/5949	Endangered
Northern Long-eared Bat <i>Myotis septentrionalis</i> No critical habitat has been designated for this species. Species profile: https://ecos.fws.gov/ecp/species/9045	Threatened

Clams

NAME	STATUS
Dwarf Wedgemussel <i>Alasmidonta heterodon</i> No critical habitat has been designated for this species. Species profile: https://ecos.fws.gov/ecp/species/784 Species survey guidelines: https://ecos.fws.gov/ipac/guideline/survey/population/363/office/52410.pdf	Endangered

Critical habitats

THERE ARE NO CRITICAL HABITATS WITHIN YOUR PROJECT AREA UNDER THIS OFFICE'S JURISDICTION.

Attachment 11

Abbreviated Essential Fish Habitat Assessment

NOAA FISHERIES
GREATER ATLANTIC REGIONAL FISHERIES OFFICE
Essential Fish Habitat (EFH) Consultation Guidance
EFH ASSESSMENT WORKSHEET

Introduction:

The Magnuson-Stevens Fishery Conservation and Management Act (MSA) mandates that federal agencies conduct an essential fish habitat (EFH) consultation with NOAA Fisheries regarding any of their actions authorized, funded, or undertaken that may adversely affect EFH. An adverse effect means any impact that reduces the quality and/or quantity of EFH. Adverse effects may include direct or indirect physical, chemical, or biological alterations of the waters or substrate and loss of, or injury to, benthic organisms, prey species and their habitat, and other ecosystem components. Adverse effects to EFH may result from actions occurring within EFH or outside of EFH and may include site-specific or habitat-wide impacts, including individual, cumulative, or synergistic consequences of actions.

This worksheet has been designed to assist in determining whether a consultation is necessary and in preparing EFH assessments. This worksheet should be used as your EFH assessment or as a guideline for the development of your EFH assessment. At a minimum, all the information required to complete this worksheet should be included in your EFH assessment. If the answers in the worksheet do not fully evaluate the adverse effects to EFH, we may request additional information in order to complete the consultation.

An expanded EFH assessment may be required for more complex projects in order to fully characterize the effects of the project and the avoidance and minimization of impacts to EFH. While the EFH worksheet may be used for larger projects, the format may not be sufficient to incorporate the extent of detail required, and a separate EFH assessment may be developed. However, regardless of format, the analysis outlined in this worksheet should be included for an expanded EFH assessment, along with additional information that may be necessary. This additional information includes:

- the results of on-site inspections to evaluate the habitat and site-specific effects
- the views of recognized experts on the habitat or the species that may be affected
- a review of pertinent literature and related information
- an analysis of alternatives to the action that could avoid or minimize the adverse effects on EFH.

Your analysis of adverse effects to EFH under the MSA should focus on impacts to the habitat for all life stages of species with designated EFH, rather than individual responses of fish species. Fish habitat includes the substrate and benthic resources (e.g., submerged aquatic vegetation, shellfish beds, salt marsh wetlands), as well as the water column and prey species.

Consultation with us may also be necessary if a proposed action results in adverse impacts to other NOAA-trust resources. Part 6 of the worksheet is designed to help assess the effects of the action on other NOAA-trust resources. This helps maintain efficiency in our interagency coordination process. In addition, further consultation may be required if a proposed action impacts marine mammals or threatened and endangered species for which we are responsible. Staff from our Greater Atlantic Regional Fisheries Office, Protected Resources Division should be contacted regarding potential impacts to marine mammals or threatened and endangered species.

Instructions for Use:

Federal agencies must submit an EFH assessment to NOAA Fisheries as part of the EFH consultation. Your EFH assessment must include:

- 1) A description of the proposed action.
- 2) An analysis of the potential adverse effects of the action on EFH, and the managed species.
- 3) The federal agency's conclusions regarding the effects of the action on EFH.
- 4) Proposed mitigation if applicable.

In order for this worksheet to be considered as your EFH assessment, you must answer the questions in this worksheet fully and with as much detail as available. Give brief explanations for each answer.

Federal action agencies or the non-federal designated lead agency should submit the completed worksheet to NOAA Fisheries Greater Atlantic Regional Fisheries Office, Habitat Conservation Division (HCD) with the public notice or project application. Include project plans showing existing and proposed conditions, all waters of the U.S. on the project site, with mean low water (MLW), mean high water (MHW), high tide line (HTL), and water depths clearly marked and sensitive habitats mapped, including special aquatic sites (submerged aquatic vegetation, saltmarsh, mudflats, riffles and pools, coral reefs, and sanctuaries and refuges), hard bottom habitat areas and shellfish beds, as well as any available site photographs.

For most consultations, NOAA Fisheries has 30 days to provide EFH conservation recommendations once we receive a complete EFH assessment. Submitting all necessary information at once minimizes delays in review and keeps review timelines consistent. Delays in providing a complete EFH assessment can result in our consultation review period extending beyond the public comment period for a particular project.

The information contained on the [HCD website](#) will assist you in completing this worksheet. The HCD website contains information regarding: the EFH consultation process; Guide to EFH Designations which provides a geographic species list; Guide to EFH Species Descriptions which provides the legal description of EFH as well as important ecological information for each species and life stage; and other EFH reference documents including examples of EFH assessments and EFH consultations.

Our website also includes a link to the [NOAA EFH Mapper](#) .

We would note that the EFH Mapper is currently being updated and revised. Should you use the EFH Mapper to identify federally managed species with designated EFH in your project area, we recommend checking this list against the [Guide to Essential Fish Habitat Designations in the Northeast](#) to ensure a complete and accurate list is provided.

EFH ASSESSMENT WORKSHEET FOR FEDERAL AGENCIES (modified 3/2016)

PROJECT NAME:

DATE:

PROJECT NO.:

LOCATION (Water body, county, physical address):

PREPARER:

Step 1: Use the Habitat Conservation Division EFH webpage's [Guide to Essential Fish Habitat Designations](#) in the Northeastern United States to generate the list of designated EFH for federally-managed species for the geographic area of interest. Use the species list as part of the initial screening process to determine if EFH for those species occurs in the vicinity of the proposed action. The list can be included as an attachment to the worksheet. Make a preliminary determination on the need to conduct an EFH consultation.

1. INITIAL CONSIDERATIONS		
EFH Designations	Yes	No
Is the action located in or adjacent to EFH designated for eggs? List the species:		
Is the action located in or adjacent to EFH designated for larvae? List the species:		
Is the action located in or adjacent to EFH designated for juveniles? List the species:		

<p>Is the action located in or adjacent to EFH designated for adults or spawning adults? List the species:</p>		
<p>If you answered 'no' to all questions above, then an EFH consultation is not required - go to Section 5. If you answered 'yes' to any of the above questions, proceed to Section 2 and complete the remainder of the worksheet.</p>		

Step 2: In order to assess impacts, it is critical to know the habitat characteristics of the site before the activity is undertaken. Use existing information, to the extent possible, in answering these questions. Identify the sources of the information provided and provide as much description as available. These should not be yes or no answers. Please note that there may be circumstances in which new information must be collected to appropriately characterize the site and assess impacts. Project plans that show the location and extent of sensitive habitats, as well as water depths, the HTL, MHW and MLW should be provided.

2. SITE CHARACTERISTICS	
Site Characteristics	Description
Is the site intertidal, sub-tidal, or water column?	
What are the sediment characteristics?	
Is there submerged aquatic vegetation (SAV) at or adjacent to project site? If so describe the SAV species and spatial extent.	
Are there wetlands present on or adjacent to the site? If so, describe the spatial extent and vegetation types.	

<p>Is there shellfish present at or adjacent to the project site? If so, please describe the spatial extent and species present.</p>	
<p>Are there mudflats present at or adjacent to the project site? If so please describe the spatial extent.</p>	
<p>Is there rocky or cobble bottom habitat present at or adjacent to the project site? If so, please describe the spatial extent.</p>	
<p>Is Habitat Area of Particular Concern (HAPC) designated at or near the site? If so for which species, what type habitat type, size, characteristics?</p>	
<p>What is the typical salinity, depth and water temperature regime/range?</p>	
<p>What is the normal frequency of site disturbance, both natural and man-made?</p>	
<p>What is the area of proposed impact (work footprint & far afield)?</p>	

Step 3: This section is used to describe the anticipated impacts from the proposed action on the physical/chemical/biological environment at the project site and areas adjacent to the site that may be affected.

3. DESCRIPTION OF IMPACTS			
Impacts	Y	N	Description
Nature and duration of activity(s). Clearly describe the activities proposed and the duration of any disturbances.			
Will the benthic community be disturbed? If no, why not? If yes, describe in detail how the benthos will be impacted.			
Will SAV be impacted? If no, why not? If yes, describe in detail how the SAV will be impacted. Consider both direct and indirect impacts. Provide details of any SAV survey conducted at the site.			
Will salt marsh habitat be impacted? If no, why not? If yes, describe in detail how wetlands will be impacted. What is the aerial extent of the impacts? Are the effects temporary or permanent?			

<p>Will mudflat habitat be impacted? If no, why not? If yes, describe in detail how mudflats will be impacted. What is the aerial extent of the impacts? Are the effects temporary or permanent?</p>			
<p>Will shellfish habitat be impacted? If so, provide in detail how the shellfish habitat will be impacted. What is the aerial extent of the impact? Provide details of any shellfish survey conducted at the site.</p>			
<p>Will hard bottom (rocky, cobble, gravel) habitat be impacted at the site? If so, provide in detail how the hard bottom will be impacted. What is the aerial extent of the impact?</p>			
<p>Will sediments be altered and/or sedimentation rates change? If no, why not? If yes, describe how.</p>			
<p>Will turbidity increase? If no, why not? If yes, describe the causes, the extent of the effects, and the duration.</p>			

<p>Will water depth change? What are the current and proposed depths?</p>			
<p>Will contaminants be released into sediments or water column? If yes, describe the nature of the contaminants and the extent of the effects.</p>			
<p>Will tidal flow, currents, or wave patterns be altered? If no, why not? If yes, describe in detail how.</p>			
<p>Will water quality be altered? If no, why not? If yes, describe in detail how. If the effects are temporary, describe the duration of the impact.</p>			
<p>Will ambient noise levels change? If no, why not? If yes, describe in detail how. If the effects are temporary, describe the duration and degree of impact.</p>			
<p>Does the action have the potential to impact prey species of federally managed fish with EFH designations?</p>			

Step 4: This section is used to evaluate the consequences of the proposed action on the functions and values of EFH as well as the vulnerability of the EFH species and their life stages. Identify which species (from the list generated in Step 1) will be adversely impacted from the action. Assessment of EFH impacts should be based upon the site characteristics identified in Step 2 and the nature of the impacts described within Step 3. The [Guide to EFH Descriptions webpage](#) should be used during this assessment to determine the ecological parameters/preferences associated with each species listed and the potential impact to those parameters.

4. EFH ASSESSMENT			
Functions and Values	Y	N	Describe habitat type, species and life stages to be adversely impacted
Will functions and values of EFH be impacted for:			
Spawning If yes, describe in detail how, and for which species. Describe how adverse effects will be avoided and minimized.			
Nursery If yes, describe in detail how and for which species. Describe how adverse effects will be avoided and minimized.			
Forage If yes, describe in detail how and for which species. Describe how adverse effects will be avoided and minimized.			
Shelter If yes, describe in detail how and for which species. Describe how adverse effects will be avoided and minimized.			

<p>Will impacts be temporary or permanent? Please indicate in description box and describe the duration of the impacts.</p>			
<p>Will compensatory mitigation be used? If no, why not? Describe plans for mitigation and how this will offset impacts to EFH. Include a conceptual compensatory mitigation plan, if applicable.</p>			

Step 5: This section provides the federal agency's determination on the degree of impact to EFH from the proposed action. The EFH determination also dictates the type of EFH consultation that will be required with NOAA Fisheries.

Please note: if information provided in the worksheet is insufficient to allow NOAA Fisheries to complete the EFH consultation additional information will be requested.

5. DETERMINATION OF IMPACT		
Federal Agency's EFH Determination		
<p>Overall degree of adverse effects on EFH (not including compensatory mitigation) will be: (check the appropriate statement)</p>		<p>There is no adverse effect on EFH or no EFH is designated at the project site. EFH Consultation is not required.</p>
		<p>The adverse effect on EFH is not substantial. This means that the adverse effects are either no more than minimal, temporary, or that they can be alleviated with minor project modifications or conservation recommendations. This is a request for an abbreviated EFH consultation.</p>
		<p>The adverse effect on EFH is substantial. This is a request for an expanded EFH consultation.</p>

Step 6: Consultation with NOAA Fisheries may also be required if the proposed action results in adverse impacts to other NOAA-trust resources, such as anadromous fish, shellfish, crustaceans, or their habitats as part of the Fish and Wildlife Coordination Act. Some examples of other NOAA-trust resources are listed below. Inquiries regarding potential impacts to marine mammals or threatened/endangered species should be directed to NOAA Fisheries' Protected Resources Division.

6. OTHER NOAA-TRUST RESOURCES IMPACT ASSESSMENT	
Species known to occur at site (list others that may apply)	Describe habitat impact type (i.e., physical, chemical, or biological disruption of spawning and/or egg development habitat, juvenile nursery and/or adult feeding or migration habitat). Please note, impacts to federally listed species of fish, sea turtles, and marine mammals must be coordinated with the GARFO Protected Resources Division.
alewife	
American eel	
American shad	
Atlantic menhaden	
blue crab	
blue mussel	
blueback herring	

Eastern oyster	
horseshoe crab	
quahog	
soft-shell clams	
striped bass	
other species:	

Useful Links

[National Wetland Inventory Maps](#)

[EPA's National Estuaries Program](#)

[Northeast Regional Ocean Council \(NROC\) Data](#)

[Mid-Atlantic Regional Council on the Ocean \(MARCO\) Data](#)

Resources by State:

Maine

[Eelgrass maps](#)

[Maine Office of GIS Data Catalog](#)

[Casco Bay Estuary Partnership](#)

[Maine GIS Stream Habitat Viewer](#)

New Hampshire

[New Hampshire's Statewide GIS Clearinghouse, NH GRANIT](#)

[New Hampshire Coastal Viewer](#)

Massachusetts

[Eelgrass maps](#)

[MADMF Recommended Time of Year Restrictions Document](#)

[Massachusetts Bays National Estuary Program](#)

[Buzzards Bay National Estuary Program](#)

[Massachusetts Division of Marine Fisheries](#)

[Massachusetts Office of Coastal Zone Management](#)

Rhode Island

[Eelgrass maps](#)

[Narraganset Bay Estuary Program](#)

[Rhode Island Division of Marine Fisheries](#)

[Rhode Island Coastal Resources Management Council](#)

Connecticut

[Eelgrass Maps](#)

[Long Island Sound Study](#)

[CT GIS Resources](#)

[CT DEEP Office of Long Island Sound Programs and Fisheries](#)

[CT Bureau of Aquaculture Shellfish](#)

[Maps CT River Watershed Council](#)

New York

[Eelgrass report](#)

[Peconic Estuary Program](#)

[NY/NJ Harbor Estuary](#)

New Jersey

[Submerged Aquatic Vegetation mapping](#)

[Barnegat Bay Partnership](#)

Delaware

[Partnership for the Delaware Estuary](#)

[Center for Delaware Inland Bays](#)

Maryland

[Submerged Aquatic Vegetation mapping](#)

[MERLIN](#)

[Maryland Coastal Bays Program](#)

Virginia

[Submerged Aquatic Vegetation mapping](#)

**ESSENTIAL FISH HABITAT ASSESSMENT ADDRESSING
THE CENTRAL HUDSON GAS & ELECTRIC
CORPORATION FORMER NORTH WATER STREET
MANUFACTURED GAS PLANT REMEDIATION PROJECT
POUGHKEEPSIE, DUTCHESS COUNTY, NY**

U.S. ARMY CORPS OF ENGINEERS

JANUARY 2018

This page intentionally left blank.

Table of Contents

1.	Introduction.....	1-1
2.	Background and Site Description.....	2-1
3.	Remedial Action Description	3-1
3.1	Barrier Wall	3-2
3.2	Dredging and Capping.....	3-2
3.3	Regulatory Jurisdiction	3-2
3.4	Description of Construction Methods	3-2
3.5	Construction Schedule.....	3-3
4.	Aquatic Environment Adjacent to Site	4-1
4.1	Water Quality.....	4-1
4.2	Tidal Conditions and Salinity	4-2
4.3	Sediment Characteristics.....	4-2
4.4	Significant Coastal Fish & Wildlife Habitats	4-4
4.5	Species in the Project Area	4-4
4.5.1	Benthic Invertebrates	4-5
4.5.2	Spatial and Temporal Fish Distributions	4-1
5.	Managed Species and EFH	5-2
5.1	Atlantic Butterfish.....	5-3
5.2	Atlantic Mackerel.....	5-3
5.3	Atlantic Sea Herring	5-4
5.4	Black Sea Bass.....	5-4
5.5	Bluefish.....	5-5
5.6	Cobia.....	5-6
5.7	King Mackerel	5-6
5.8	Red Hake.....	5-6
5.9	Scup	5-7
5.10	Spanish Mackerel.....	5-7
5.11	Summer Flounder	5-8
5.12	Winter Flounder	5-8
5.13	Windowpane Flounder.....	5-8
6.	Impact Analysis.....	6-1
6.1	Water Column Habitat	6-1

6.2	Benthic Habitat and Invertebrates.....	6-1
6.3	Submerged Aquatic Vegetation and Significant Coastal Fish and Wildlife Habitats.....	6-2
6.3.1	Submerged Aquatic Vegetation.....	6-2
6.3.2	Significant Coastal Fish and Wildlife Habitats.....	6-2
6.4	Fish.....	6-2
6.5	Essential Fish Habitat.....	6-4
7.	Endangered Species Concerns.....	7-1
8.	Mitigation Activities.....	8-1
8.1	Land-based Controls.....	8-1
8.2	Water-based Controls.....	8-1
9.	References.....	9-1

Appendix A Dredging Figures

Appendix B Product Description Sheets – Slope Stabilization Material

List of Figures

Figure 1	Site Vicinity.....	1-2
Figure 2	Existing Conditions.....	2-2
Figure 3	Dredge Areas.....	3-4
Figure 4	Dredge and Capping Areas.....	3-5
Figure 5	Turbidity Curtain (Typical).....	3-6
Figure 6	SSC Concentration South of Poughkeepsie based on USGS data from 2002-2009.....	4-3
Figure 7	Benthic Invertebrate Sample Locations.....	6

List of Tables

Table 1	Benthic Invertebrates – Project Area.....	4-7
Table 2	Summary of Essential Fish Habitat (EFH) Designations.....	5-2

1. Introduction

This Essential Fish Habitat assessment is prepared on behalf of the Central Hudson Gas & Electric Corporation (CHGE) to support the United States Army Corps of Engineers (USACE) Nationwide Permit (NWP) #38 application to conduct work in the Hudson River in compliance with the New York State Department of Environmental Conservation (NYSDEC) *Decision Document* (March 2016) for the Former North Water Street Manufactured Gas Plant (MGP) site (NYSDEC Site No. C314070) in the City of Poughkeepsie, Dutchess County, NY (Figure 1).

The Magnuson Fisheries Conservation and Management Act of 1976 was passed to promote sustainable fish conservation and management. The 1996 amendments to the Magnuson-Stevens Fishery Conservation and Management Act strengthened the ability of the National Marine Fisheries Service (NMFS) and regional councils to protect and conserve the habitat of marine, estuarine, and anadromous finfish, mollusks, and crustaceans. This habitat is termed "essential fish habitat" (EFH) and is broadly defined to include "those waters and substrate necessary to fish for spawning, breeding, feeding, or growth to maturity."

As required by the Magnuson-Stevens Act, the NMFS promulgated regulations to provide guidance to the regional fishery management councils for EFH designation. The regulations further clarify EFH by defining waters to include aquatic areas and their associated physical, chemical, and biological properties that are used by fish, which may encompass a substrate to include sediment, hard bottom, structures underlying the waters, and associated biological contribution to a healthy ecosystem; and areas used for spawning, breeding, feeding, or growth to maturity to cover a species' full life cycle.

This EFH assessment was prepared in compliance with the Magnuson-Stevens Fishery Conservation and Management Act (1996 amendments), Section 7 of the Endangered Species Act of 1973 (as amended), Fish and Wildlife Coordination Act of 2002 (as amended), and under the guidance of the New York District of the USACE.

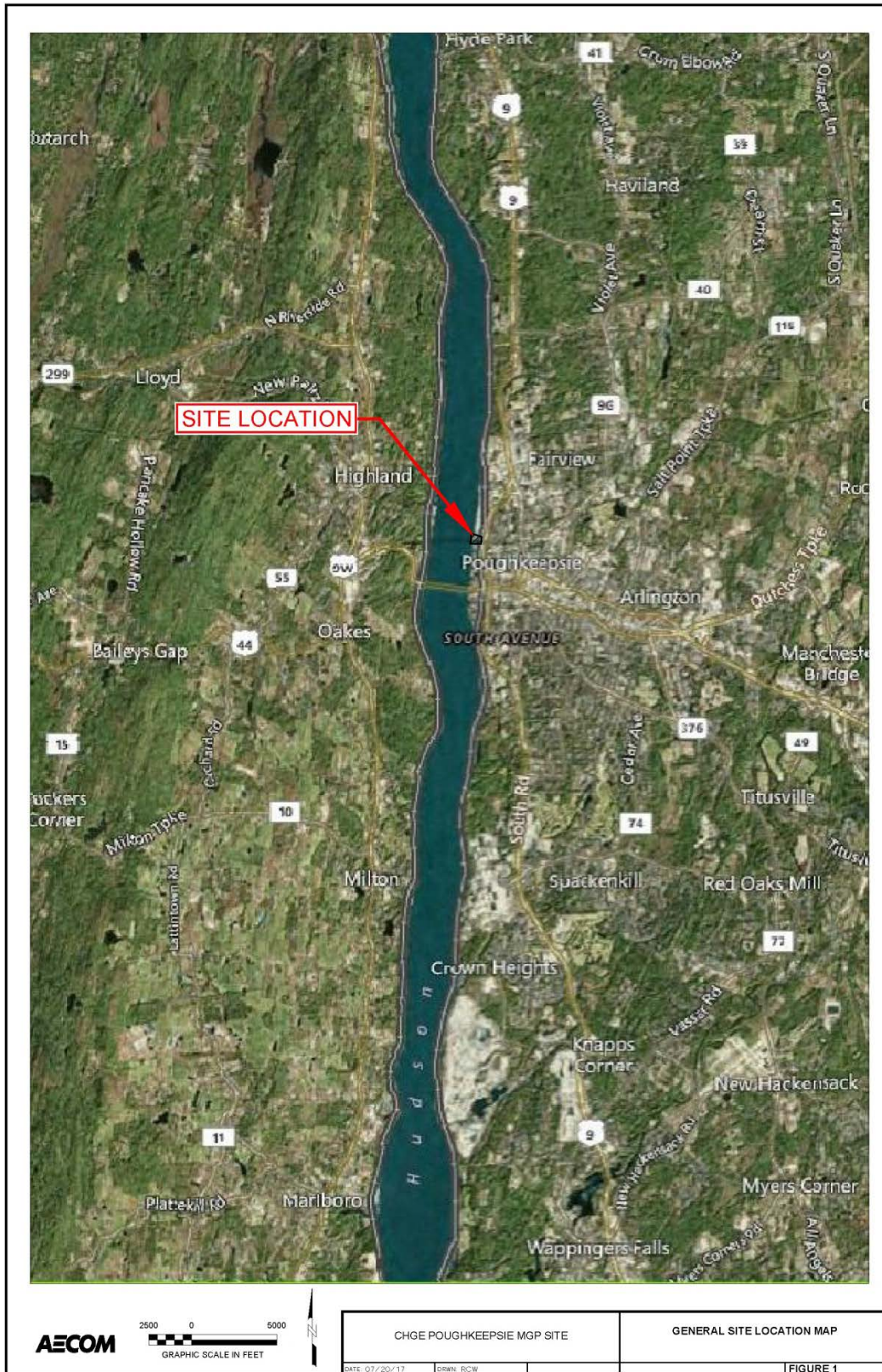

Figure 1 Site Vicinity

2. Background and Site Description

The former North Water Street MGP (site) is located at 2 Dutchess Avenue in the City of Poughkeepsie, Dutchess County, New York. The site is bounded by Dutchess Avenue to the north, North Water Street and Amtrak railroad lines to the east, Upper Landing Park and Fall Kill Creek to the south, and the Hudson River to the west. Tidal movements affect the Hudson River adjacent to the site. Figure 2 depicts the bathymetric contours of the Hudson River adjacent to the shoreline on the CHGE property.

The site was operated as a carbureted water gas MGP from 1911 to 1950. CHGE has owned the site since 1926. During peak operation waste by-products were recycled at the site, and during this process by-products were reported to have seeped into the Hudson River from unintentional spills near the tar separator. To prevent additional seepage of by-products into the river, a clay dike was installed between the railroad siding and the river in the 1940s. Today, residuals from these releases are in the form of non-aqueous phase liquid (NAPL); more specifically dense non-aqueous phase liquid (DNAPL) is the primary form of site contamination to be addressed.

CHGE will perform an environmental remediation at the site per the Brownfield Cleanup Agreement (BCA) Index Number D3-0004-99-04 executed between CHGE and the NYSDEC in May 2005. The NYSDEC-selected remedy to address the environmental impacts identified at the site and in the Hudson River adjacent to the site is presented in the March 2016 Decision Document.

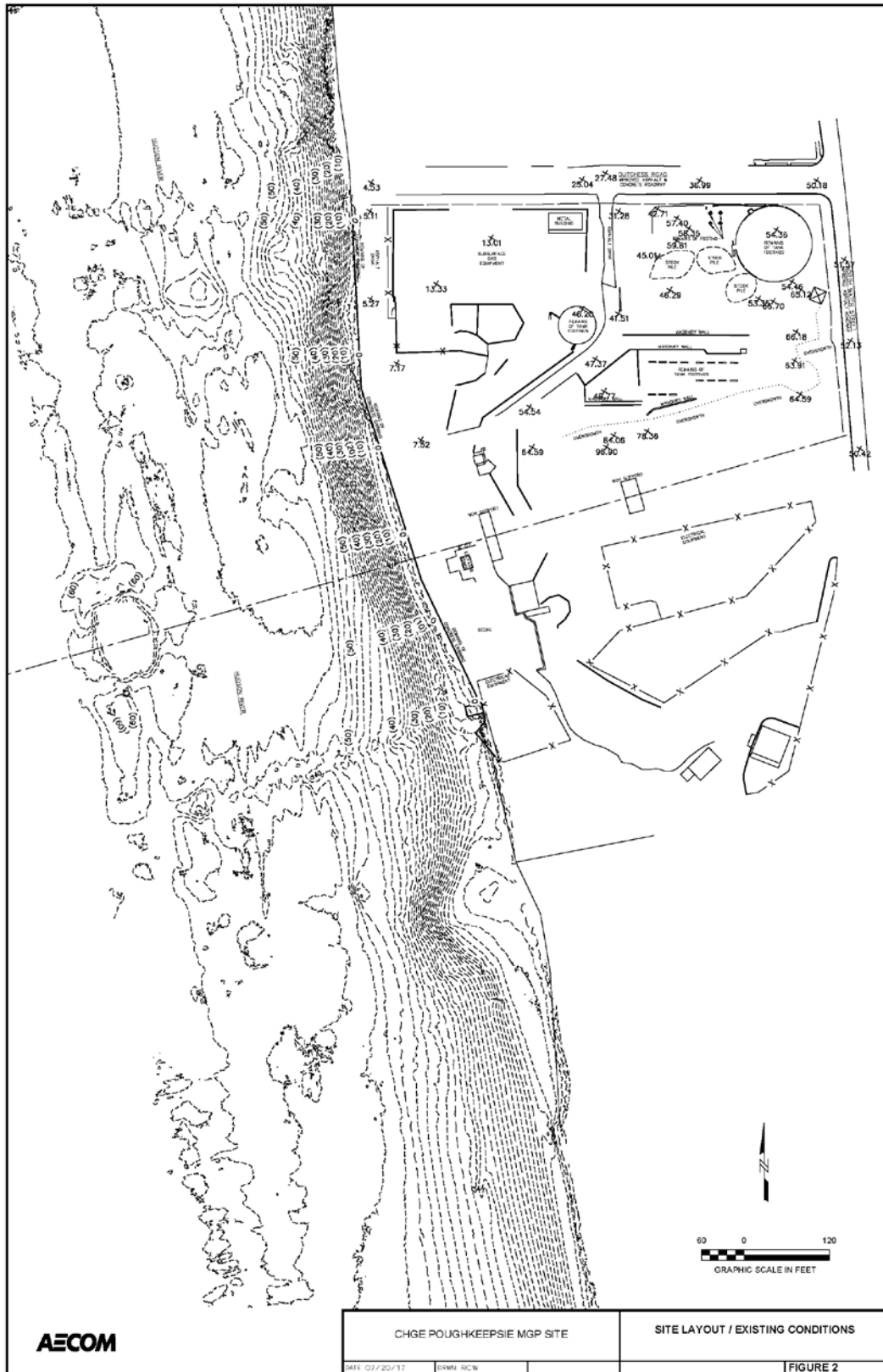

Figure 2 Existing Conditions

3. Remedial Action Description

The selected remedy for the site as documented in the NYSDEC Decision Document (NYSDEC 2016) includes:

- Excavation and off-site disposal of upland contamination from the source areas located in the northern portion of the lower terrace areas of the site (not part of this permit application).
- Installation of a subsurface barrier wall along the east bank of the Hudson River to prevent migration of coal tar to the River (not part of this permit application).
- Installation of a series of NAPL recovery wells behind the barrier wall to collect DNAPL that might accumulate behind the wall. NAPL will be collected from these recovery wells periodically (not part of this permit application).
- Installation of a NAPL recovery well in the area north of the barrier wall where the natural gas pipeline enters the upland portion of the site, which precludes the safe construction of the barrier wall. Initially in-situ solidification (ISS) was proposed for this area, but due to small size of this area, ISS is not practical. Installation of a NAPL recovery well in lieu of ISS in this area was presented to the NYSDEC during a meeting on November 8, 2017 to capture any NAPL that may be migrating towards the Hudson River (not part of this permit application).
- Dredging of NAPL impacted sediments from the bed of Hudson River where feasible.
- Placement of cover system consisting of Reactive Core-Mats (RCM) overlain by armored concrete blocks over the impacted sediment areas near and above the underwater utility crossings, where dredging cannot be performed.
- Placement of articulated capping system consisting of RCM with grout filled molds over the riverbank slope immediately adjacent to the site where dredging would create significant safety concerns due to potential for slope instability. The capping system will prevent migration of the remaining contamination in the riverbank into the Hudson River.
- Placement and maintenance of the cover system over the site to allow for industrial use of the site. The cover system will consist of structures, pavements, or soil cover in areas where the exposed soil will exceed the applicable Soil Cleanup Objectives (SCOs) (not part of this permit application).
- River and riverbank restoration that incorporate measures to maximize wildlife habitat while protecting energy infrastructure and allowing for potential future development of a public access walkway along the riverbank.
- Establishing institutional controls in the form of an environmental easement for the upland portion of the site. Institutional controls in the upland areas would be established to limit subsurface intrusive activities that could result in potential exposure to soil and groundwater, limit the use of the site, prohibit the use of the site groundwater, and require compliance with the Site Management Plan (SMP) (not part of this permit application).

- Preparing a SMP to document institutional controls, known locations of soil and sediments containing NAPL impacts, protocols for conducting intrusive activities, protocols for periodic monitoring, and reporting requirements(not part of this permit application).

Of the remedial activities listed above, the dredging and capping activities in the Hudson River and along the river side slope are subject to NWP 38 and described here. Approximately 7.6 acres of dredging (Figure 3) would be conducted to remove approximately 40,000 cubic yards (CYs) of sediment impacted by the operation of the former MGP facility. Dredging of sediments that are visually impacted with NAPL from the areas identified on Figure 3 is proposed to be conducted between October 2018 and February 2019.

3.1 Barrier Wall

To prevent migration of coal tar to the river, installation of a subsurface barrier wall along the east bank of the Hudson River will be conducted. Subsequently, there will be the installation of a series of NAPL recovery wells to collect NAPL that might accumulate behind the wall. NAPL will be collected from these recovery wells periodically.

3.2 Dredging and Capping

To remove NAPL impacted sediments from the bed of Hudson River, dredging will be conducted where feasible (Figure 3). A full set of dredging figures that depicts the various dredge areas, capping and methods is provided in Appendix A. A sand cap will be placed in select dredged areas. In areas of impacted sediment near and above the underwater utility crossings, where dredging cannot be performed, the placement of cover system consisting of RCM overlain by armored concrete blocks will be conducted (Examples of sediment/slope stabilization materials are provided in Appendix B).

In areas of impacted sediment along the riverbank slope where dredging would create significant safety concerns due to slope instability, an articulated capping system will be placed consisting of RCM with grout filled molds (Appendix B). The capping system will prevent migration of the remaining contamination in the riverbank into the Hudson River.

3.3 Regulatory Jurisdiction

The dredging and capping activities in the Hudson River and along the river shoreline slope are subject to the jurisdiction of the USACE. Approximately 7.6 acres of dredging (Figure 3) would be conducted in the Hudson River to remove approximately 40,000 CYs of sediment impacted by the operation of the former MGP facility. There would also be approximately 1.2 acres of capping along the riverbank slope (Figure 4).

3.4 Description of Construction Methods

Dredging will be conducted using an environmental bucket within a containment cell. The containment cell will be attached to the dredge barge which will be outfitted with turbidity curtains and floating booms on all sides of the dredge polygon (Figure 5) to control the transport of contaminated sediment beyond the

dredging area. Water quality (turbidity) will be monitored for the duration of the dredging by means of three buoy-mounted remote sensing stations that will be moored around the perimeter of the work area.

Dredged areas deeper than 2 feet below the existing bathymetry will be backfilled after dredging with certified clean sand (approximately 31,000 CYs) imported from upland sources and transported to the site via barge. The clean sand will be placed on approximately 4.2 acres of the dredged areas using specially fabricated conveyors and tremie technology that will discharge the sand from a tremie pipe. To the extent practicable and constructible, the tremie pipe will extend to the dredge surface. The clean sand backfill will be placed in the dredged areas to within 2 feet of the adjacent bottom elevation to support the restoration of the river bottom to pre-dredge bathymetry. The sand will consist of a granular material of sufficient size and density that is expected to fall through the portion of the water column beyond the tremie pipe to the river bottom at its placement location with minimal dispersion. Clean sand was selected specifically to maximize accuracy of the fill placement operation and minimize suspension and transport of backfill material outside of the intended placement location.

The river bottom will be allowed to reestablish its original (pre-dredging) bathymetry within the dredged areas by natural sediment transport processes. Sediment deposition and subsequent erosion is a natural cycle within a stable riverbed; while specific rates of sedimentation and erosion in the vicinity of Poughkeepsie are not available, sedimentation rates of approximately 40 centimeters (1.3 feet) within a period of months (typically, during the spring freshet) are observed within the Lower Hudson River as a whole. Dredging of the impacted sediment will create areas of the river bottom below the surrounding bathymetry and function as natural sediment traps; consequently, it is expected that sediment transport within the dredged areas will only be depositional in nature until the pre-existing stable bathymetry is restored, after which the natural long-term deposition and erosion cycle will resume.

The slope of the shoreline along the site cannot be dredged to remove impacted sediment due to the shallow depth and stability issues with the slope. A subsurface steel sheet pile wall will be installed as part of the upland and bulkhead remediation activities. To isolate the impacted sediment remaining beyond the sheet pile bulkhead wall from the river, approximately 1.22 acres of an articulated capping system consisting of RCM with grout filled molds will be installed along the river slope. This will require a cut volume of approximately 1,722 CYs and a backfill volume of approximately 6,775 CY (Appendix A provides all related dredging figures and details, including slope and sediment stabilization materials).

Since dredging cannot be conducted in the area of the existing underwater gas, electric, and fiber optic lines that extend across the Hudson River, approximately one acre area near and over the utility crossings will be capped with a cover system consisting of RCM overlain by armored concrete blocks to isolate the impacted sediment in these areas (Figure 4).

3.5 Construction Schedule

Dredging of the contaminated sediment is proposed to be conducted between October 2018 and February 2019. Additionally, the less intrusive capping of the underwater utility areas and river bank slope is anticipated to be conducted between July 2019 and September 2019, after the published key migratory spawning season (March 1 through June 30).

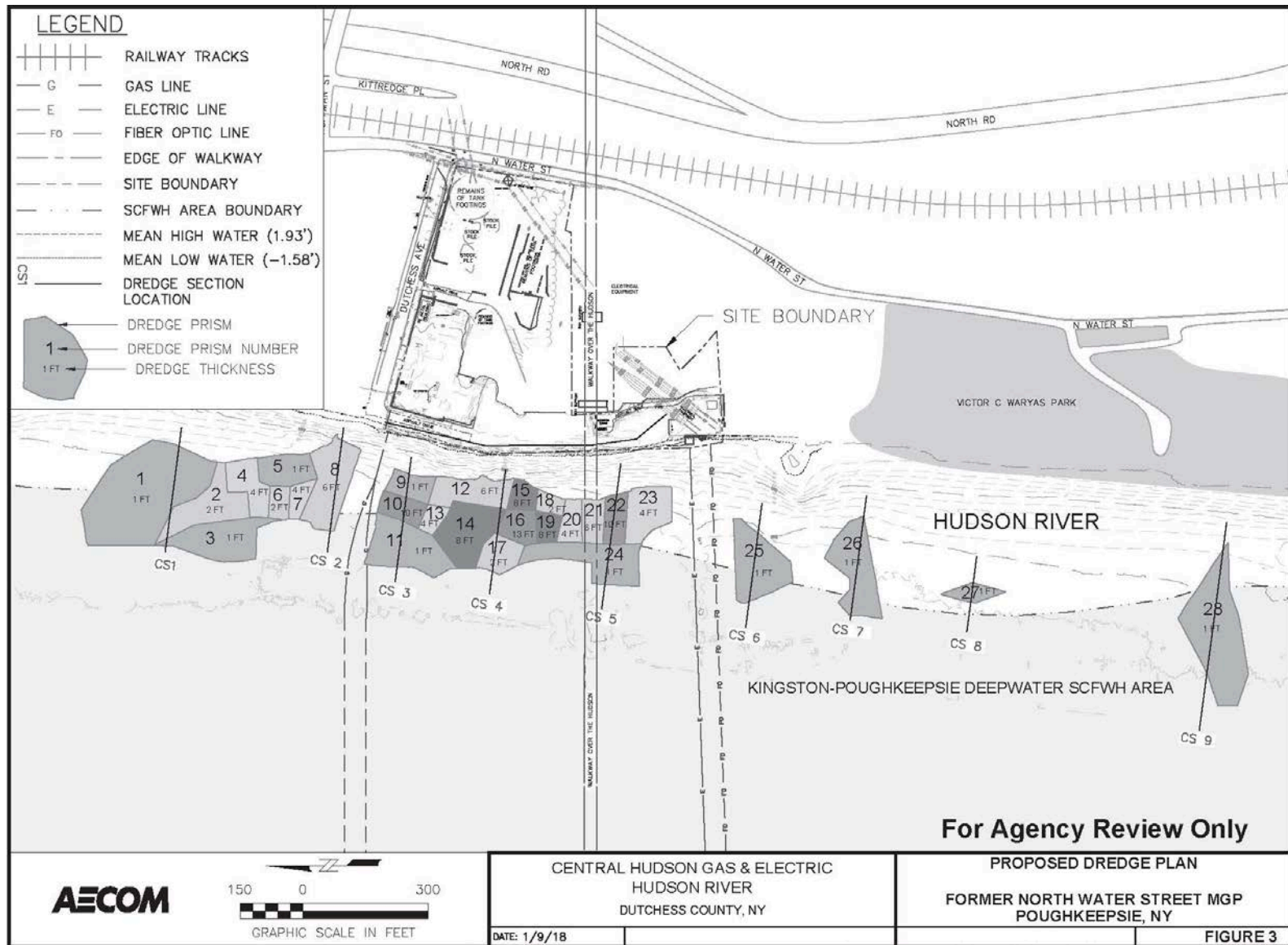

Figure 3 Dredge Areas (Proposed Dredge Plan)

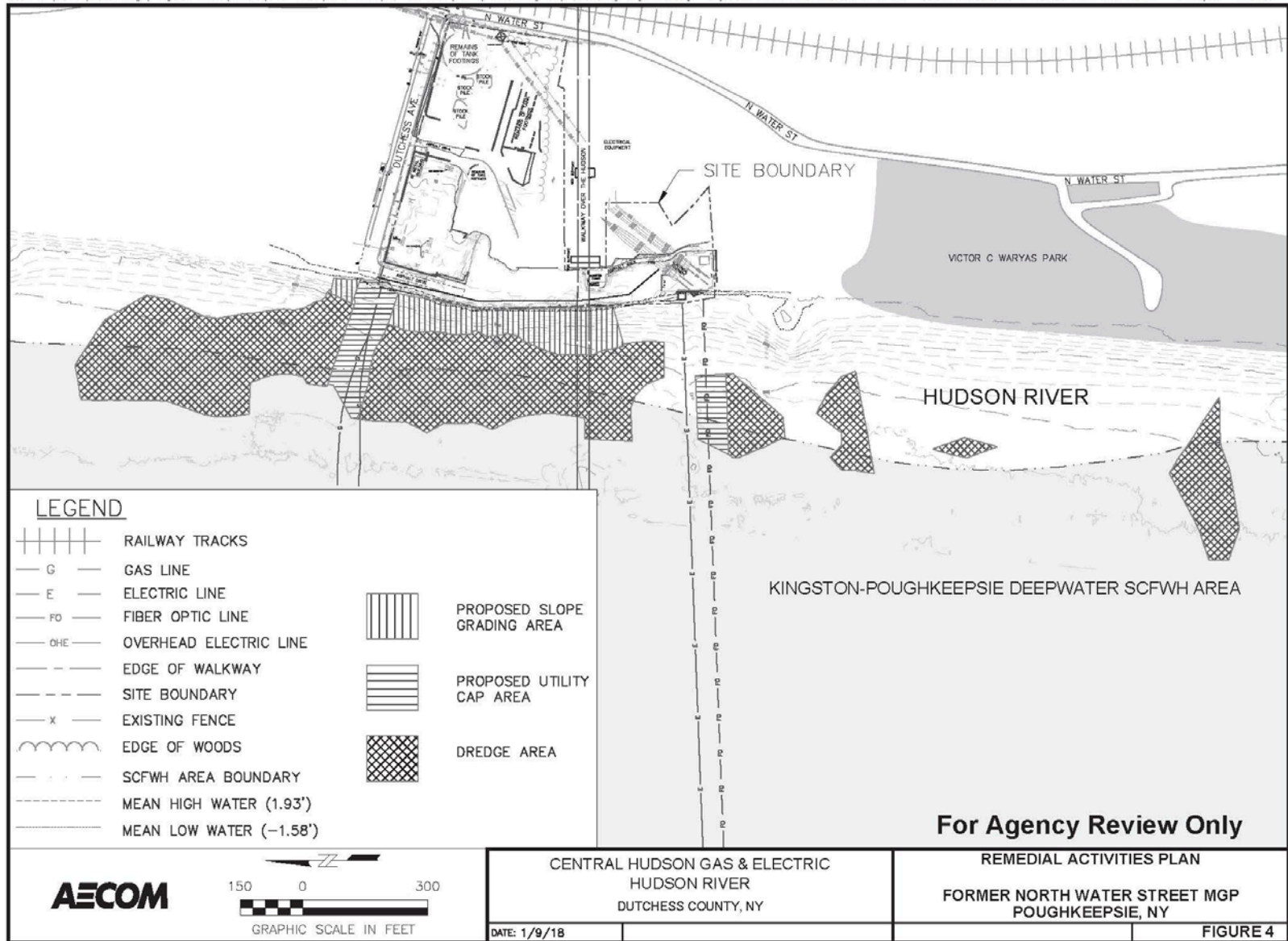

Figure 4 Dredge and Capping Areas

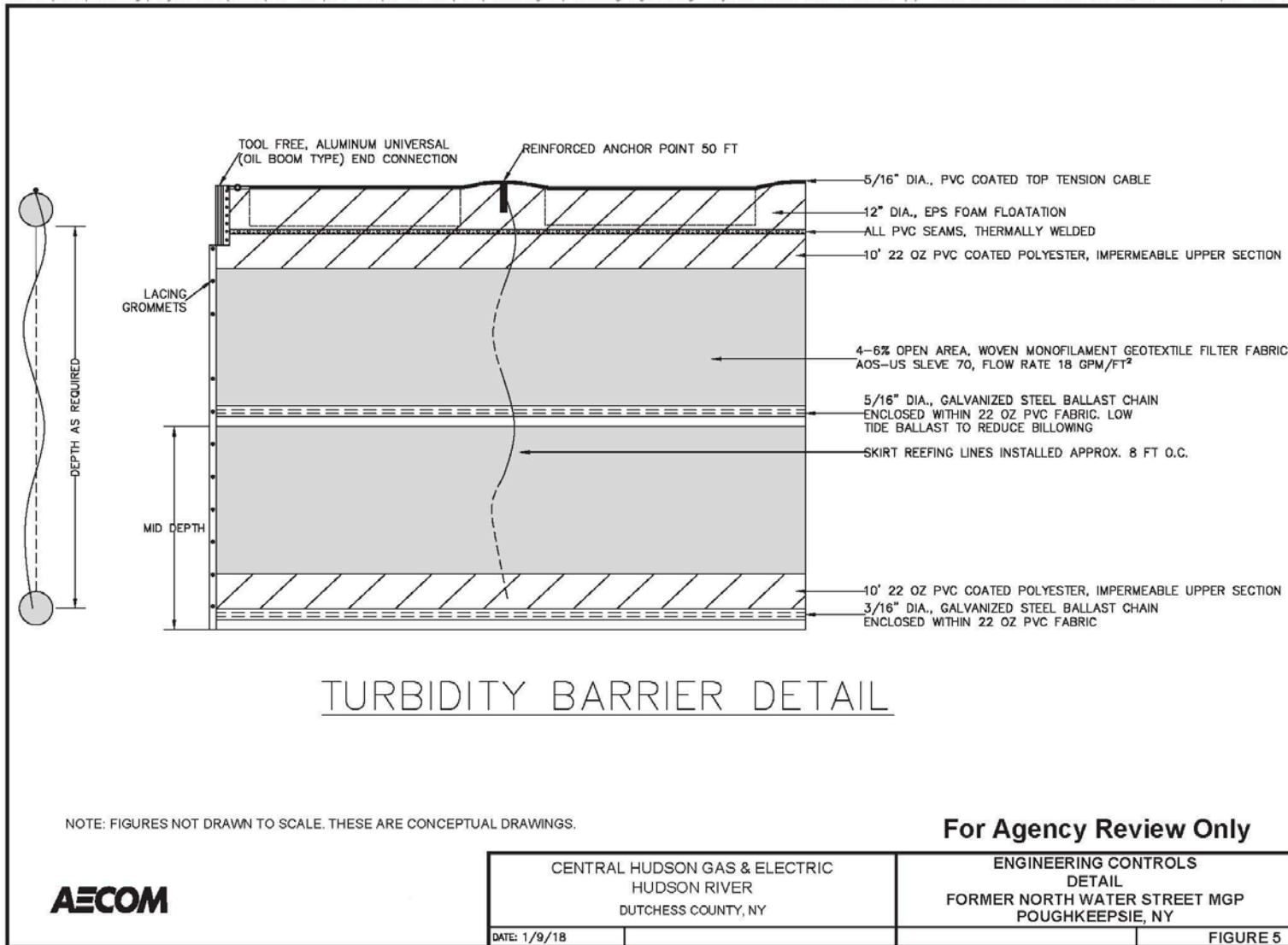

Figure 5 Turbidity Curtain (Typical)

4. Aquatic Environment Adjacent to Site

The site is located on the Hudson River, approximately 83 river miles (RM) north of New York Harbor, and 75 RM below the Federal Dam in Troy. The Hudson River is tidal below the Federal Dam.

4.1 Water Quality

The water quality classification at the project site is a driving factor in assessing project impacts. The Hudson River near the site is classified by NYSDEC as Class A fresh surface water. Class A waters are a source of water supply for drinking, culinary or food processing purposes, primary and secondary contact recreation, and fishing. The waters are suitable for fish, shellfish and wildlife propagation and survival (6 NYCRR Part 701.6). The water quality classification for Fall Kill Creek where it borders the southern portion of the site is Class C fresh surface water. The best usage of Class C waters is fishing, with suitability for primary and secondary contact recreation with potential limits.

The parameters typically associated with suspended sediments, such as turbidity or total suspended solids (TSS), colloidal, and settleable solids, do not have numeric water quality standards (6 NYCRR Part 703.2). However, the narrative standards state that an action should not increase turbidity sufficiently to result in a substantial visible contrast to natural conditions, or any suspended, colloidal or settleable solids from sewage, industrial or other wastes that would cause deposition or impair the waters for their best use.

The Hudson River Estuary (HRE) is well studied and a significant number of data sources exist. A United States Geologic Survey (USGS) gauge south of Poughkeepsie (approximately four miles downstream of the site) continuously monitors suspended sediment concentration (SSC) as well as water quality parameters. The USGS gauge south of Poughkeepsie uses backscatter information from an acoustic Doppler current profiler (ADCP) to estimate suspended solids concentration (Wall et al., 2006). Using the SSC estimates combined with the current data measured by the device, an estimate of total sediment discharge is also calculated.

The Hudson River Environmental Conditions Observing System (HRECOS) is an environmental monitoring network in the Hudson River watershed. HRECOS monitoring stations are equipped with sensors that continuously record a variety of water quality and weather parameters every 15 minutes, with most stations operating year-round. Remote telemetry at each station transmits real-time data for the public to freely view and download using an easily-accessible interface at hrecos.org. A HRECOS station is located approximately one half mile upstream of the site at Marist College in Poughkeepsie (HRECOS, 2017).

Available guidance and precedent suggest that the suspended solids concentrations in a project area do not need to be rigorously defined, as (1) water quality standards for suspended solids are typically defined in relative rather than absolute terms, and (2) existing background conditions do not materially alter the behavior of sediments resuspended by project-related activities. However, for the purposes of impact evaluation, a concept of the typical sediment concentrations at the project site, and their variability, is still useful. To aid in this understanding the yearly variation at the USGS gauge south of Poughkeepsie is presented in Figure 6.

The HRE has a long history of environmental disturbance, including shoreline modifications, dredging impacts/channelization, and pollution. Many habitats are impacted or threatened by toxic chemicals, increased sedimentation and turbidity, and non-point source pollution from agricultural and residential watersheds. Treated sewage effluent is discharged into many Hudson River tributaries by towns and villages. Many older municipalities have aging sewage treatment systems with clay pipes, along with inadequate pump stations and treatment plants. This decaying infrastructure permits raw sewage to enter the estuary under conditions of heavy rainfall (Cooper et al., 1988). However, recent funding initiatives, authorized by the New York State Clean Water/Clean Air Bond Act of 1996, have made significant progress towards improvement of older wastewater infrastructure in many municipalities along the Estuary (NYSDEC, 2005).

4.2 Tidal Conditions and Salinity

The Hudson River is tidally influenced from the Battery to the Federal Dam at Troy, NY, 153 miles north. Tides at the Battery have an average range of 4.5 feet, with the mean range decreasing to 3.1 feet at Poughkeepsie and gradually increasing again to 4.7 feet at the Federal Dam (NOAA, 2016). The majority of freshwater flow enters the Hudson River north of the Federal Dam at Troy, with the remaining freshwater flow entering from various tributaries downstream of the dam. Freshwater flow in the Hudson estuary follows a typical seasonal pattern, with highest flow during the spring and lowest flow during late summer and early fall. Water temperatures measured near the site range from -0.10 degrees Celsius in the winter to 28.8 degrees Celsius in the summer based on monitoring gauges near the site (USGS, 2017a; HRECOS, 2017).

Although the reach of the Hudson River that is adjacent to the site is classified as freshwater, saline water is still present upstream of the site. The mid-estuary from Stony Point to Poughkeepsie is generally the oligohaline zone (0.5 to 5 parts per thousand salinity) in the Hudson, including the seasonal inland extent of brackish water in the Hudson, although the limits of this zone change with the amount of freshwater flow (USFWS, 1997). The extent of the salt front (the location at which the chloride concentration equals 100 milligrams per liter) generally occurs in the southern part of the Hudson River but may reach as far north as Poughkeepsie during very dry years (USGS, 2017b).

4.3 Sediment Characteristics

In December of 2017, a sediment sampling and benthic invertebrate sampling program occurred within the dredge prisms and river bank slope. Sediments were generally comprised of silts that have been affected by the presence of NAPL. Also, in isolated locations gravels, woody detritus and other materials were encountered. These materials are likely surficial in nature and associated with prior bridge construction and other industrial activities in the greater project area.

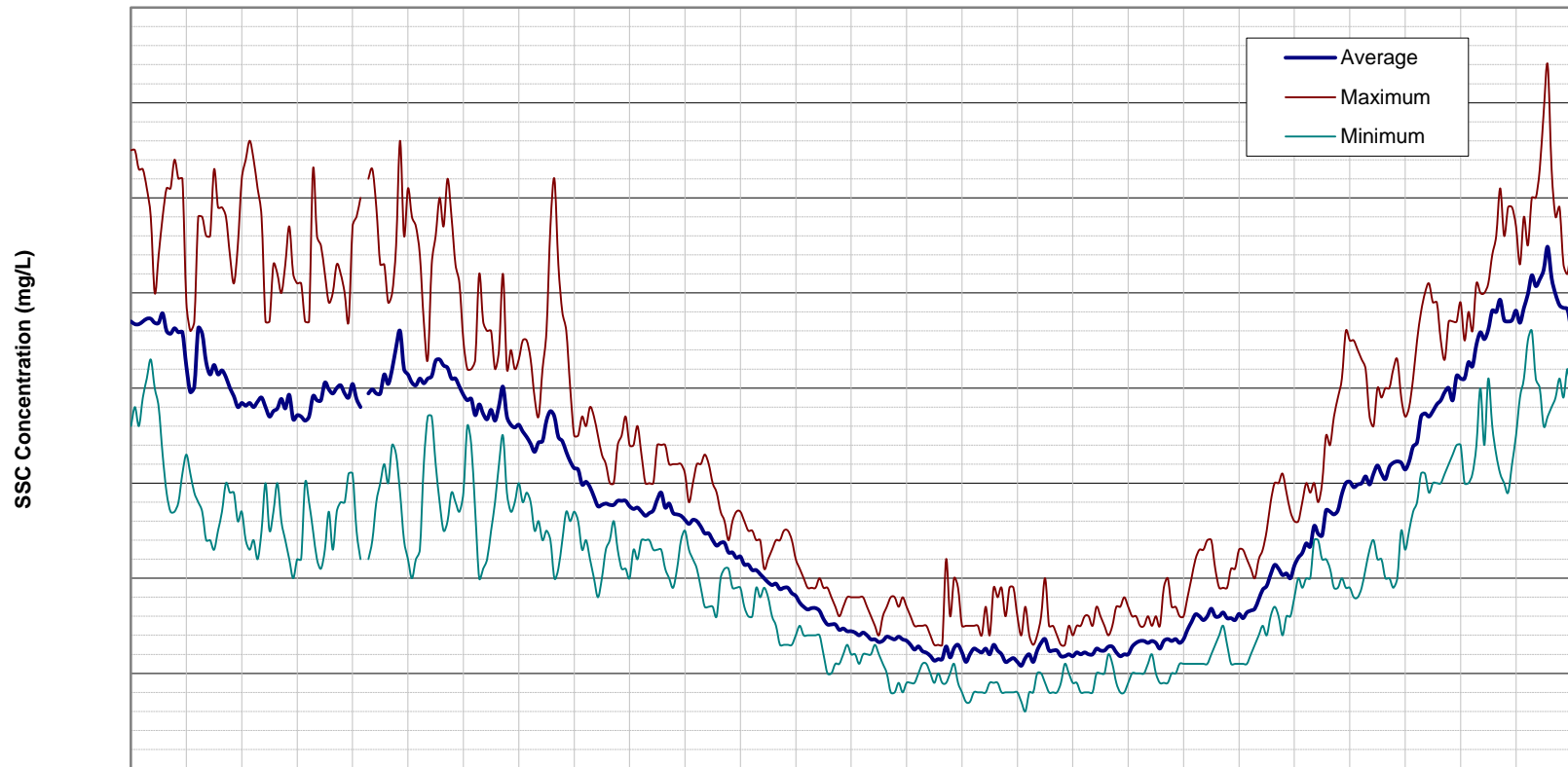

Figure 6 SSC Concentration South of Poughkeepsie based on USGS data from 2002-2009

4.4 Significant Coastal Fish & Wildlife Habitats

The Kingston-Poughkeepsie Deepwater Habitat is an approximately 6,350 acre habitat that encompasses a 25 mile stretch of the Hudson River extending approximately from Kingston Point in the City of Kingston in Ulster County and the Village of Rhinecliff in Dutchess County to just south of Wappinger Creek in the Town of Wappinger in Dutchess County. This habitat area is a nearly continuous Deepwater section of the river, from a water depth of 20 feet to the bottom, and especially where water depths of 50 feet or greater occur. The Kingston-Poughkeepsie Deepwater Habitat is the northernmost extensive section of deepwater habitat in the Hudson River. The Kingston-Poughkeepsie Deepwater habitat has been designated as a Significant Coastal Fish and Wildlife Habitat (SCFWH) by the NYSDEC (NYSDOS, 2012). Dredging in the SCFWH area of approximately 25,000 CYs within approximately 4 acres will be conducted using an environmental bucket within a containment cell which will be outfitted with turbidity curtains that extend to the river bottom and floating booms on all sides to control turbidity beyond the dredging area.

Deepwater areas provide wintering habitat for shortnose sturgeon and support a diversity of marine species in the Hudson River. The Kingston-Poughkeepsie Deepwater Habitat is believed to be the northernmost wintering location of shortnose sturgeon in the Hudson River. Recent fisheries investigations of the Hudson River indicate spawning as well as wintering of sturgeon in this area. Although habitat requirements of this species in the Hudson River are not well known, it is believed that these deepwater areas may be critical year round. Shortnose sturgeon use the portion of the river which generally is greater than 30 feet in depth. This area is also significant since it is largely responsible for the abundance of marine species upriver (the northern range limit for many in New York), especially during periods of low freshwater flows (summer). During the spring spawning run of shad, commercial drift netting takes place in the surface waters overlying this area (NYSDOS, 2012).

4.5 Species in the Project Area

The fish populations of the HRE are well studied. For 35 years, area utility companies have been performing seasonal sampling of various life stages throughout the river. In addition, federal and state regulatory agencies, such as National Oceanic and Atmospheric Administration (NOAA), and NYSDEC, as well as independent researchers (e.g., Pisces Conservation LTD, 2008; Heimbuch, 2008, etc.) have published numerous reports on the river's fisheries resources.

Over 200 species of fish have been noted within the Hudson River estuary according to the NYSDEC (NYSDEC, 2017). A total of 48 species of fish were observed during the 2017 NYSDEC “*Great Hudson River Estuary Fish Count*” at Waryas Park (located approximately one-half mile downstream of the project site). While not an exhaustive list of species occurring in the project area, the species noted below were collected on August 5, 2017 via seining operations conducted from shore as part of an educational event: blueback herring (*Alosa aestivalis*), American shad (*Alosa sapidissima*), golden shiner (*Notemigonus crysoleucas*), spotfin shiner (*Cyprinella spiloptera*), spottail shiner (*Notropis hudsonius*), shiner species, white sucker (*Catostomus commersonii*), banded killifish (*Fundulus diaphanous*), striped bass (*Morone saxatilis*), rock bass (*Ambloplites rupestris*, *Ambloplites constellatu*), red-breasted sunfish (*Lepomis auritus*), pumpkinseed (*Lepomis gibbosus*), smallmouth bass (*Micropterus dolomieu*), largemouth bass (*Micropterus salmoides*), tessellated darter (*Etheostoma olmstedii*), yellow perch (*Perca flavescens*), and

logperch (*Percina caprodes*). Of these, the majority of fish caught were young of the year, including all of the individuals of migratory species.

4.5.1 Benthic Invertebrates

The zebra mussel (*Dreissena polymorpha*) is known to occur in and near the Hudson River from Albany to Haverstraw Bay (United States Fish and Wildlife Service [USFWS] 1997). Zebra mussels are filter feeding bivalves capable of achieving significant filtration rates, which reduce available water column food chain production (USFWS 1997). Reduction in phytoplankton and detritus volumes may reduce the zooplankton species that feed upon them and could result in localized fisheries-related impacts (USFWS 1997). However, the sediments that contain these detritus material in the areas where dredging will be conducted are heavily impacted with NAPL and harmful to the zebra mussels and other species mentioned above.

Benthic communities vary in distribution depending on bottom water salinity, with a typically marine benthos from Stony Point south dominated by marine worms and crustacea, a mixture of freshwater and marine organisms between Stony Point and Poughkeepsie, and freshwater snails, clams, chironomids, and insects north of Poughkeepsie (USFWS, 1997).

In December 2017, sampling to identify benthic invertebrates was conducted in the project area. Benthic samples were obtained through the use of a Van Veen Grab sampler. The grab collected sediments from the Hudson River bottom. The grab sample was then brought to the surface and the sediments were washed away over a screen table. The remaining contents were then placed in a container with a preservative and biological stain. Later, the remaining materials were examined with a microscope and all species were identified to the lowest possible taxon. Nine mid-stream, three shoreline and two reference locations were sampled (Figure 7).

As can be observed in Table 1 below, a typical assemblage of Hudson River benthic invertebrates were observed in both the dredge prism areas and the two reference locations¹. Due to composition substrate along the shoreline, two of the three shoreline sites were unable to produce fine-grained sediment samples, and at the one that collected a sample only zebra mussels and one blue mussel shell was observed. The zebra mussel, an invasive species, was observed at several locations. Blue mussel shell fragment were observed at several sample locations, but only the two reference sites and Location 27 samples yielded any live species. Some amphipods were observed at most sites but were not observed at either of the reference sites. Other species observed in small quantities at some sites include isopods, clams, midge larvae, American eel, and snails, although often samples contained only fragments rather than live specimen. Many of the samples exhibited a strong odor or sheen, likely as a result of historic contamination.

¹ Reference Locations 1 was located approximately 2,500 feet north of Dutchess Avenue off the eastern shoreline. N 41.718205, W -73.939893

Reference Location 2 was located approximately 2,900 feet northwest of Dutchess Avenue off the western shoreline. N 41.716921, W-73.948095

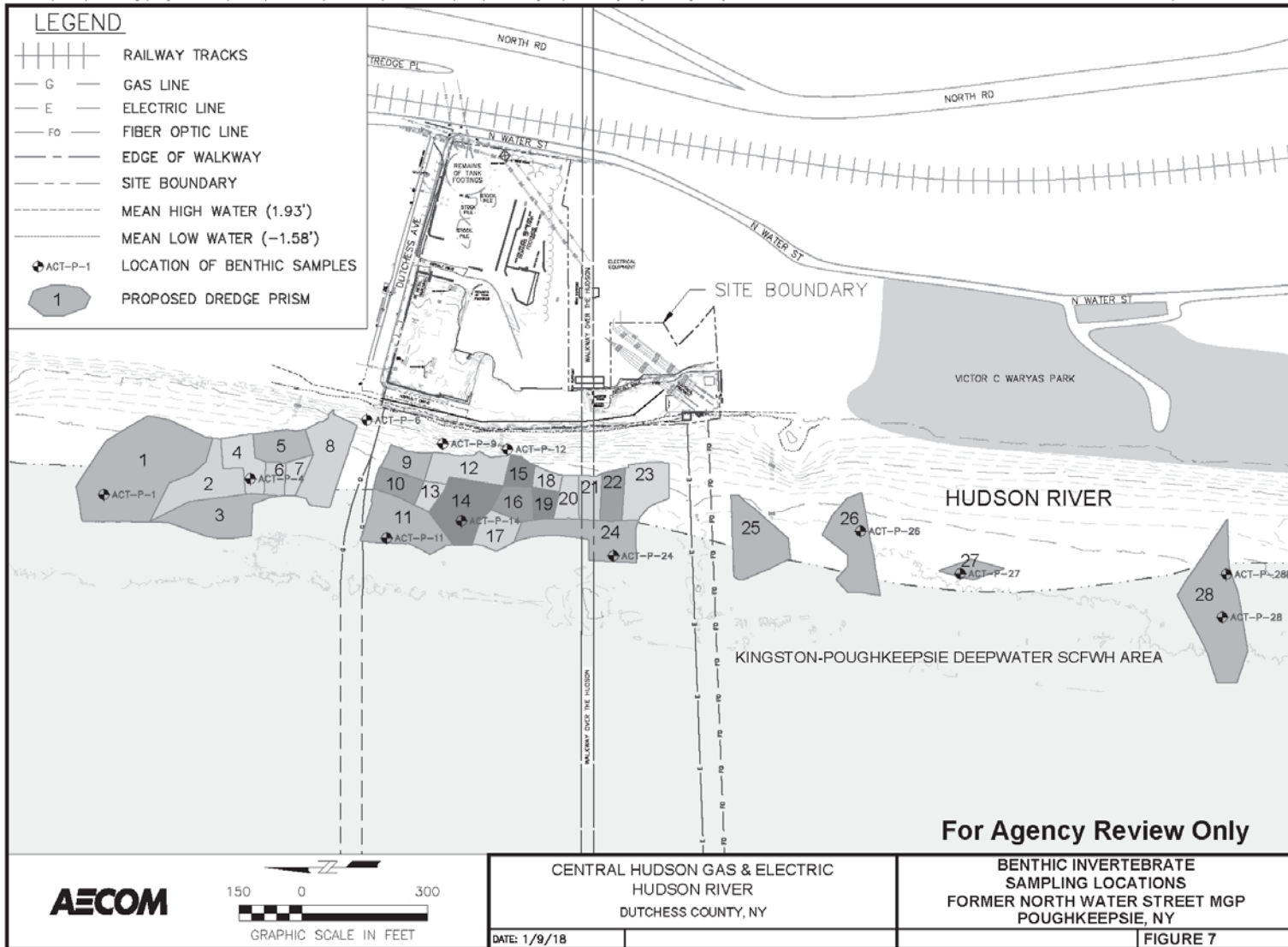

Figure 7 Benthic Invertebrate Sample Locations

Table 1
Benthic Invertebrates – Project Area

Site ^a	Depth ^b (feet below surface)	Substrate Composition	Zebra mussel ^c (<i>Dreissena polymorpha</i>)	Amphipod (<i>Gammaridea</i> sp.)	Slender Isopod (<i>Cyathura</i> sp.)	Asian clam (<i>Corbicula</i> sp.)	Midge larvae (<i>Chironomidae</i> sp.)	Blue mussel (<i>Mytilus edulis</i>)	American eel (<i>Anguilla rostrata</i>)	Insecta sp.	Bivalve sp.	Faucet snail (<i>Bithynia tentaculata</i>)	Gastropod sp.	Other
ACT-P-1	54	Silt, some coarse sand and leaf litter.	20	1										Woody detritus, some black grit, few pieces of gravel. 1 hogchoker flounder.
ACT-P-4	55	Silt, some coarse sand and leaf litter.	10	5				1 SF						Woody detritus with some leaves. Sheen and odor.
ACT-P-11	60	Silt.	25											Woody detritus with some black grit. Sheen and odor.
ACT-P-14	53	Silt, some coarse sand.	15	4		1	2		1					Woody detritus with some tar blobs. Some sheen.
ACT-P-24	56	Silt, some gravel, some coarse sand, shells, rock and brick fragments.	205	3				1 SF						Some gravel with slag, coarse sand and black grit. Strong odor.
ACT-P-26	53	Silt, some gravel and coarse sand.	23			2	1				1 SF			Some gravel, coarse sand and black grit. Woody detritus, gravel and slag. Sheen and odor.
ACT-P-27	58	Silt, some shells.	210					4 live, 3 SF						Gravel, slag, some black grit. Sheen and odor.
ACT-P-28	52	Silt, some shells.	126	2		3 SH	2	1 SF	1	1 WF				Woody detritus with some coarse sand, black grit and shell fragments.
ACT-P-28B	55	Silt, some shells.	300	7	1			6 SF						Gravel, some slag, coarse sand and grit.
ACT-P-12	25	Refusal, no sample collected. 1 large stone encrusted with zebra mussels.											No sample collected.	
ACT-P-9	30	Refusal, no sample collected.											No sample collected.	
ACT-P-6	20	Silt, some coarse sand and gravel.	25					1 SF				1		Rocks, gravel, slag, coarse sand, and black grit, some woody detritus.
Reference 1	51	Silt, some shells.	21			1	1	1 live, 2 SF						Gravel with coal, slag, coarse sand, black grit, and woody detritus. Some sheen.
Reference 2	35	Silt.	300					1 live				1	1 EF	Woody detritus with some black grit, gravel, sticks, slag, and coarse sand.

Notes: Three samples were collected at each site location. Results show the aggregate of the three samples.

- a. Indicates the average depth of the three samples.
- b. Zebra mussel counts include shells and fragments.
- c. SF = Shell Fragment; SH = Shell; WF = Wing Fragment; Eroded/Fossilized Shell

Also, within the dredge prisms, some of the benthic habitat would be considered impaired as it contains NAPL or other debris materials. This may contribute to the lack of abundance or diversity in many of the samples.

4.5.2 Spatial and Temporal Fish Distributions

Due to the long length of the river, and inputs of freshwater from tributaries and tidal actions, the salinity levels are not homogeneous throughout the estuary. Seasonal variations in temperature and precipitation levels alter the levels of salinity within the estuary. The northern portions of the river are freshwater, but are influenced by tidal action, so that the lower portion of the Hudson River is a dynamic system that witnesses dramatic fluctuations in species diversity and biomass from season to season. Within the project area, salinities are generally less than 5 parts per thousand (ppt), which would exclude the presence of many marine and estuarine species.

5. Managed Species and EFH

To delineate EFH, coastal littoral and continental shelf waters were first mapped by the regional FMCs and then superimposed within ten minute-by-ten minute (10' x 10') square coordinate grids. Finally, survey data, gray literature, peer-review literature, and reviews by academic and government fisheries experts were all used by the FMCs to determine whether these 10' x 10' grids support EFH for federally managed species. The Mid-Atlantic Fisheries Management Council (MAFMC) has designated EFH in the lower portion of the Hudson River.

Review of the National Oceanographic and Atmospheric Administration (NOAA) "Summary of Essential Fish Habitat (EFH) Designation" for the Hudson River indicates that up to 13 federally managed species may utilize the Hudson River for part or all of their life history (Table 2). However, four listed species (summer flounder, king mackerel, Spanish mackerel, and cobia) were noted as primarily marine species.

A description of the life history and use of the Hudson River for each species listed in Table 2 is provided below.

Table 2
Summary of Essential Fish Habitat (EFH) Designations

Species	Eggs	Larvae	Juveniles	Adults	Spawning Adults
Red hake (<i>Urophycis chuss</i>)		M,S	M,S	M,S	
Winter flounder (<i>Pleuronectes americanus</i>)	M,S	M,S	M,S	M,S	M,S
Windowpane flounder (<i>Scopthalmus aquosus</i>)	M,S	M,S	M,S	M,S	M,S
Atlantic sea herring (<i>Clupea harengus</i>)		M,S	M,S	M,S	
Bluefish (<i>Pomatomus saltatrix</i>)			M,S	M,S	
Atlantic butterfish (<i>Peprilus triacanthus</i>)		M	M,S	M,S	
Atlantic mackerel (<i>Scomber scombrus</i>)			S	S	
Summer flounder (<i>Paralichthys dentatus</i>)		F,M,S	M,S	M,S	
Scup (<i>Stenotomus chrysops</i>)	S	S	S	S	
Black sea bass (<i>Centropristus striata</i>)			M,S	M,S	
King mackerel (<i>Scomberomorus cavalla</i>)	X	X	X	X	
Spanish mackerel (<i>Scomberomorus maculatus</i>)	X	X	X	X	
Cobia (<i>Rachycentron canadum</i>)	X	X	X	X	
Notes: n/a = Species either have no data available on the designated lifestages, or those lifestages are not present in the species' reproductive cycle.					

Species	Eggs	Larvae	Juveniles	Adults	Spawning Adults
<p>M = The EFH designation for this species includes the mixing water/ brackish salinity zone of the HRE (0.5% < salinity < 25.0%). S = The EFH designation for this species includes the seawater salinity zone of the HRE (salinity > or = 25.0%). F = The EFH designation for this species includes the tidal freshwater salinity zone of the HRE (0.0% < or = salinity < or = 0.5%). X = All areas of the river are classified as EFH.</p> <p>Source: NOAA, 2017</p>					

5.1 Atlantic Butterfish

The Atlantic butterfish (*Peprilus tricanthus*) ranges from Newfoundland to Florida, but is primarily found from the Gulf of Maine to Cape Hatteras. Butterfish migrate in response to seasonal changes in water temperature. During summer, butterfish move northward and inshore to feed and spawn. Spawning occurs during June to August and peaks progressively later at higher latitudes. During winter, butterfish move southward and offshore to avoid cool waters. Butterfish are primarily pelagic and form loose schools that feed upon small fish, squid, and crustaceans.

Butterfish have a high natural mortality rate and are preyed upon by many species, including silver hake, bluefish, swordfish, and long-finned squid. The NMFS has designated the salinity zone of Hudson River as EFH for Atlantic butterfish larvae and the mixing and salinity zones as EFH for butterfish juveniles and adults. It is unlikely that butterfish occur in the project area due to the low salinities.

5.2 Atlantic Mackerel

The Atlantic mackerel (*Scomber scombrus*) is a fast-swimming, pelagic, schooling species distributed in the northwest Atlantic between Labrador and North Carolina and are primarily found in the open sea (although rarely beyond the continental shelf) from Black Island, Labrador (Parsons 1970) to Cape Lookout, North Carolina (Collette and Nauen 1983). Eggs, larvae and juveniles also found at varying levels of abundance in bays and estuarine areas from New Jersey north through New England and into Canadian waters. Atlantic mackerel are opportunistic feeders that can ingest prey either by individual selection of organisms or by passive filter feeding (Pepin et al. 1988).

This population has two major spawning components: a southern group that spawns primarily in the Mid-Atlantic Bight during April and May, and a northern group that spawns in the Gulf of St. Lawrence in June and July. Both groups winter between Sable Island (off Nova Scotia) and Cape Hatteras in waters generally warmer than 45° F (7° C), with extensive northerly (spring) and southerly (autumn) migrations to and from spawning and summering grounds. The eggs are pelagic in water over 34 ppt, floating in surface waters above the thermocline or in the upper 10 to 15 meters.

Regulations on landings of Atlantic mackerel were enforced in 1976 in hopes of reducing fishing effort so as to ensure reproductive success in the population by keeping spawning stock levels above devastating levels. Recruitment has increased since 1976-1980 and strong year classes were evident in 1982, 1987, 1988, and 1990-1993 (Northeast Fisheries Science Center 1996). The NMFS has designated the Hudson River salinity zone as EFH for Atlantic mackerel juveniles and adults. It is unlikely that mackerel occur in the project area due to the low salinities and distance from the Atlantic Ocean.

5.3 Atlantic Sea Herring

The Atlantic herring (*Clupea harengus*) is a pelagic, schooling, plankton-feeding species that inhabits both sides of the North Atlantic Ocean. Atlantic herring are usually seen swimming in vast schools offshore (Geiser, 1984). In the western North Atlantic this species ranges from Labrador to Cape Hatteras and supports major commercial fisheries. Adult herring undergo complex north-south migrations for feeding, spawning, and overwintering. Herring produce demersal eggs and spawn during the summer and fall in the Gulf of Maine – Georges Bank region. Larvae overwinter offshore and in coastal waters and metamorphose into juveniles in the spring. Juveniles and adults are heavily preyed upon by a variety of marine fish, marine mammals, and seabirds (NOAA, TM 192, 1999). Eggs are demersal and are typically deposited on gravelly substrates (Reid et al., 1999).

In 1999, the NOAA Technical Memo for the species indicated that the U.S. stock complex has fully recovered from the effects of over-exploitation during the 1960s and 1970s and is currently under-utilized, although there is concern that exploitation rates in the Gulf of Maine may be too high. The NMFS has designated the Hudson River mixing and salinity zone as EFH for Atlantic sea herring larvae, juveniles, and adults. Due to the geographical location of the project area, it is unlikely that herring adults, larvae, or eggs would be present in the project area.

5.4 Black Sea Bass

Black sea bass (*Centropristus striata*) are strictly confined to salt water, appearing inshore during the first or second week in May and withdrawing again late in October or early in November. The substrate preferred by the black sea bass generally consists of shellfish and eelgrass beds, man-made structures in sandy-shelly areas, and offshore clam beds (Bigelow and Schroeder, 1953). Although, young of the year (YOY) fish also occur in large numbers in structurally complex estuarine habitats (NOAA TM 200, 2007). During the part of the year when the black sea bass are inshore they are most plentiful on hard bottom, in water depths of less than 115 feet (35 m) or so, often around submerged wrecks. They are bottom feeders, subsisting chiefly on crabs, lobsters, shrimp, and various mollusks (Bigelow and Schroeder, 1953).

Juvenile and adult black sea bass occur in the demersal waters over the Continental Shelf from the Gulf of Maine to Cape Hatteras, North Carolina. Juvenile and adult black seas bass are found in the estuaries in the summer and spring in water warmer than 43° F (6° C) with salinities greater than 18 ppt, but winter offshore from south of New York to North Carolina (Steimle et al., 1999a). Black sea bass eggs are pelagic. Berrien and Sibunka (1999) as cited in NOAA TM 200, 2007 showed that in the Mid-Atlantic Bight, areas with high average egg densities were generally located on the continental shelf in the vicinity of large estuaries including Chesapeake Bay, the Delaware River, and the Hudson River. Eggs are collected off Cape Hatteras as early as January but these may be reproductive products transported by the Gulf Stream from spawning areas to the south (Mercer 1978, as cited in NOAA TM 200, 2007).

The NMFS has designated the Hudson River mixing and salinity zones as EFH for black sea bass juveniles and adults. It is unlikely that this species occur in the project area due to the low salinities.

5.5 Bluefish

Bluefish (*Pomatomus saltatrix*) are common inshore inhabitants of the New York Bight, arriving in May and usually departing by November. Two major spawning aggregations are in the mid-Atlantic – a spring spawning stock and a summer spawning stock. Most of the bluefish population in the New York Bight probably originates from the spring spawning stock. The spring spawners move into the waters where the Gulf Stream and the continental shelf waters meet between northern Florida and Cape Hatteras. Bluefish spawn as they migrate northward. North of Cape Hatteras, the adults move shoreward.

The smaller, post-spawned bluefish may spend summers in the Chesapeake and Delaware Bays and Albemarle Sound. Larger fish move north for a longer period than the smaller bluefish, and thus migrate farther. Some move into Long Island Sound and more northern areas. In autumn, bluefish migrate back to the wintering areas off south Florida and the South Atlantic Ocean.

Bluefish eggs are buoyant and pelagic and hatch in about two days. The newly hatched larvae are also pelagic and remain in offshore waters for one to two months before migrating shoreward toward shallow-water nursery areas; for this reason, no early life-stages were collected in the study area during the utilities' studies. Young-of-the-year (YOY) bluefish typically first enter areas north of the George Washington Bridge in early June and remain there until at least early October. They are most common in shallow, more saline areas of the estuary, but can range as far upriver as the Cornwall region. Salinity intrusions into the estuary appear to be a major determinant of geographic distribution within the estuary. YOY bluefish are also abundant in areas of the estuary south of the George Washington Bridge and adjacent waterways, which are part of the larger, coastal distribution (ASA, 2006).

Seasonal migrations of bluefish represent an important recreational and commercial fishery during the summer months along the northeastern shores of the US. Although spawning offshore during summer, juveniles move in large numbers into the warmer inshore waters of the bay. These fish are voracious feeders, consuming a wide variety of fish and invertebrates in the water column. Mackerels, menhadens, alewives, herrings, and weakfish, as well as shrimp, lobsters, squid (*Loligo opalescens*), crabs, mysids, and annelid worms, are all part of the bluefish's diet. The abundance of juveniles in shallow nearshore waters also provides an important source of prey for other predatory species. The NMFS has designated the Hudson River mixing and salinity zones as EFH for bluefish juveniles and adults. Except for brief

periods in the summer when salinities are higher, it is unlikely that this species occur in the project area due to the low salinities.

5.6 Cobia

The cobia (*Rachycentron canadum*) is a fast-swimming fish that can be found near shore or inshore inhabiting inlets, bays, and mangrove swamps and is often seen around buoys, pilings, and wrecks. Cobia are distributed from Massachusetts to Argentina. Cobia primarily feed on crabs, squid, and small fish and can reach a size of up to 6 feet and 331 pounds (lbs), although they more commonly reach a size of between 22 and 110 lbs (Robins et al., 1986). The NMFS has designated the Hudson River as EFH for cobia eggs, larvae, juveniles, and adults. However, due to low salinities in the project area, it is unlikely that the species would often be present near the project.

5.7 King Mackerel

The king mackerel (*Scomberomorus cavalla*) is a fast-swimming fish that roams in schools. Their distribution ranges along the western coast of the Atlantic Ocean from North Carolina to Massachusetts and also in the Gulf of Mexico (Beaumariage, 1973). They prefer warm waters and are found along reefs and in coastal waters. Peak spawning occurs from May to early July and in late July to early August. King mackerel primarily feed on other fish and reach a size of up to 5.6 feet and 99.2 pounds (NMFS, 2017).

King mackerel are a "coastal pelagic" species, meaning they live in the open waters near the coast. They are typically found at depths of 115 to 591 feet (NMFS, 2011); although, they are sometimes found close to shore. King mackerel are voracious feeders that may be seen leaping out of water in pursuit of prey. Juvenile king mackerel prey on larval fish; adults prey on fish, squid, and shrimp and reach a size of up to 66 in and 220 lbs (NMFS, 2011).

King mackerel migrate to the northern part of their range in the summer and to the southern part in the winter. Migrations are based on water temperature and availability of food. King mackerel also form large schools. King mackerel span from May through October on the Outer Continental Shelf (NMFS, 2011). The NMFS has designated the Hudson River as EFH for king mackerel eggs, larvae, juveniles, and adults. Due the low salinities in the project area, it is unlikely this species utilizes the project area.

5.8 Red Hake

Red Hake (*Urophycis chuss*) are distributed from the Gulf of St. Lawrence to North Carolina, but are most abundant between Georges Bank and New Jersey. Red hake undergo extensive seasonal migrations, moving into shallow waters to spawn in spring and summer and offshore to deep waters in the winter. Spawning occurs from May through November. The eggs are buoyant (Geiser, 1984) and are generally found in water temperatures below 50°F (10°C).

The first months of a red hake's life are spent drifting at or near the surface, and fry of 0.5 to 4 in have been observed in summer under floating eelgrass or rockweed. Juvenile red hake are often found near benthic habitats with abundant shell fragments, including areas with abundant sea scallops (NEFMC EFH, 1998). Adult red hake are often found in water temperatures below 54°F at depths of between 33 and 98 feet with a salinity range of 33 to 34 ppt (NEFMC EFH, 1998). The red hake's diet consists

primarily of shrimp, squid, bergalls, small eels, spearing, sand eels, and the young of other species (Geiser, 1984).

The NMFS has designated the Hudson River mixing and salinity zone as EFH for red hake larvae, juveniles, and adults. Due the low salinities in the project area, it is unlikely this species utilizes the project area.

5.9 Scup

Scup (*Stenotomus chrysops*) occur primarily in the Mid-Atlantic Bight from Cape Cod to Cape Hatteras. The scup population in the Middle Atlantic Bight spawns along the inner continental shelf off southern New England from May through August with a peak in June to July. Larvae occur in coastal waters during the warmer seasons, feed upon small zooplankton, and are prey to a variety of planktivores, including medusae, crustaceans and fish. Larvae settle to the seafloor in coastal and estuarine waters when they are about 25 mm in length, but this event is poorly documented. During the summer and early fall, juveniles and adults are common in most larger estuaries and coastal areas in open and structured habitats where they feed on a variety of small benthic invertebrates (NOAA TM 149, 1999).

The life history of scup is typical of most demersal fishes, with pelagic eggs and larvae, and a gradual transition to the demersal adult stage. As a temperate species, scup is at the northern limits of its range in the northeastern United States and migrates seasonally during spring and autumn. In summer, scup are common in inshore waters from Massachusetts to Virginia, while in winter, scup are found in offshore waters between Hudson Canyon and Cape Hatteras. Spawning occurs during summer months (Steimle et al., 1999c).

In 1999, the NOAA Technical Memo for the species indicated that commercial landings of scup in the Middle Atlantic Bight have declined substantially since peak landings in the 1950s and early 1960s; although there was a minor peak in landings in the early 1980s. The Middle Atlantic Bight stock is currently considered overfished because the stock is near record low abundance levels (NMFS TM 149, 1999). The NMFS has designated the Hudson River as EFH for scup eggs, larvae, juveniles, and adults. Except for brief periods of time in the summer when salinities are higher, it is unlikely this species utilizes the project area.

5.10 Spanish Mackerel

The Spanish mackerel (*Scomberomorus maculatus*) is a fast-swimming fish that roams in large schools. Spanish mackerel can be found near shore congregating around channels and bays, and are distributed from Cape Cod to South Florida, although they are rarely found north of the Chesapeake Bay (Robbins et al., 1986). Spawning occurs from July to August and as late as September. Larvae can be found within inshore waters at temperatures of about 68 to 86 degrees F. Juveniles prefer estuarine and coastal waters. Adult habitat ranges from tidal estuaries to open water and adults prefer water temperatures of 69.8 to 80.6 degrees F (ASMFC, 2016). Spanish mackerel primarily feed on shrimp, squid, and small fish and reach a size of up to 37 in and 24 lbs. The NMFS has designated the Hudson River as EFH for Spanish mackerel eggs, larvae, juveniles, and adults. However, due to low salinities in the project area, it is unlikely that the species would often be present near the project.

5.11 Summer Flounder

Summer flounder (*Paralichthys dentatus*) or fluke, occur from the southern Gulf of Maine to South Carolina. Summer flounder are concentrated in bays and estuaries from late spring through early autumn, when an offshore migration to the outer continental shelf is undertaken. On the outer shelf they are found at depths of up to 148 feet. Many summer flounder come close inshore when the waters are warm, but the great majority of the population, especially larger fish, lies farther offshore at that time of year (Bigelow and Schroeder, 1953). Adult and juvenile summer flounder normally inhabit shallow coastal and estuarine waters during the warmer months of the year and remain offshore during the fall and winter (NOAA TM 151, 1999).

Summer flounder spawn during the fall and winter while the fish are moving offshore or onto their wintering grounds; the offshore migration is presumably keyed to declining water temperature and decreasing photoperiod during the autumn. Larvae are transported toward coastal areas by prevailing water currents.

Development of post-larvae and juveniles occurs primarily within bays and estuarine areas. Summer flounder often bury themselves in the soft bottom of the ocean or river. They consume small fish, most notably small mossbunker, squid, mackerel, sea robins, sand eels, killifish, and spearing. NMFS has designated the Hudson River mixing and salinity zones as EFH for summer flounder larvae, juveniles, and adults. Due to the low salinities in the project area, it is unlikely this species utilizes the project area.

5.12 Winter Flounder

Winter flounder (*Pleuronectes americanus*) are distributed in the northwest Atlantic from Labrador to Georgia. The species is found in brackish and salt water habitats. Abundance is highest from the Gulf of St. Lawrence to Chesapeake Bay. Optimum substrate for adults and juveniles is silty sand. The diet consists primarily of benthic invertebrates. Movement patterns are generally localized. Winter flounder undertake small-scale migrations into estuaries, embayments, and saltwater ponds in winter to spawn, subsequently moving to deeper water during summer. Winter flounder tend to return to the same spawning locations in consecutive years. Optimum water temperature for spawning is 34° to 39.2° F. Females usually produce between 500,000 to 1.5 million eggs. Eggs are adhesive and settle to the bottom (New England Fishery Management Council, 1998).

Generally, winter flounder release their eggs within areas that are less than 50°F, with salinities from 10 to 30 ppt, and in depths of less than 15 feet. Larval winter flounder are often found in shallow water at depths of less than 18 feet (6 m) (NEMFC EFH, 1998). Juvenile and adult flounder can be found in waters of 163 and 328 feet in depth, respectively. The NMFS has designated the Hudson River as EFH for winter flounder eggs, larvae, juveniles, adults, and spawning adults. Due to the low salinities and deep depths of the project area, winter flounder would not use the project area as a spawning resource.

5.13 Windowpane Flounder

Windowpane flounder (*Scophthalmus aquosus*), also known as sand flounder, are distributed on the northwest Atlantic continental shelf from the Gulf of St. Lawrence to Florida. This species inhabits large estuaries and is a shoal water benthic species that prefers sandy bottoms, as its name implies. However, it

also frequents softer and muddier grounds (Bigelow and Schroeder, 1953). Windowpane is not a target of the commercial fishing industry, but is mainly caught as bycatch in bottom trawl fisheries (NOAA TM 137, 1999).

Peak spawning activity occurs in Mid-Atlantic Bight waters (which extend from Montauk, NY to the Virginia/North Carolina border), in May and October. The eggs of the windowpane flounder are spherical and buoyant. Stomach content data collected during Northeast Fisheries Science Center (NEFSC) bottom trawl surveys indicate windowpane feed on small crustaceans (e.g., mysids and decapod shrimp) and various fish larvae including hakes and tomcod, as well as their own species (NOAA TM 137, 1999). The NMFS has designated the Hudson River as EFH for winter flounder eggs, larvae, juveniles, adults, and spawning adults. Due the low salinities in the project area, it is unlikely this species utilizes the project area.

6. Impact Analysis

Impacts from sediment resuspension due to dredging activities have the potential to occur. Based on the project duration (approximately 4 months for dredge activity), the relatively small dredging and capping areas (approximately 7.6 and 2.5 acres, respectively) compared to the overall size of the habitat, and the implementation of best management practices (BMPs) and engineering controls (discussed in Section 8), the impacts to species utilizing available EFH are expected to be minimal.

6.1 Water Column Habitat

The increase of resuspended sediments would generally be minimal and well within the normal background levels of the area, with the exception a few areas of higher concentrations in the immediate vicinity of the dredge. The resuspended materials would not affect water quality and would result in localized negligible increases. Moreover, these areas of higher concentration would represent a minute fraction of the available water column within the river.

6.2 Benthic Habitat and Invertebrates

A wide array of benthic fauna occurs in the Hudson River. The aquatic fauna vary from motile and sessile benthic organisms to resident and early life stages of numerous fish species. These organisms could be impacted by sediment resuspension that may interfere with their methods of feeding (i.e., filter feeders) and/or impair their habitat due to an increase in suspended sediments or burial through deposited sediments.

Habitats can vary from densely submerged aquatic vegetated beds to habitats with high rugosity environments (e.g., reefs, large boulders, etc.) to relatively flat, featureless sediment-dominated habitats. Although devoid of vegetation or lacking dramatic topographical variability, benthic sediments provide valuable habitat for numerous benthic invertebrates (e.g., worms, clams, etc.). Moreover, these interstitial organisms serve as prey species for fish, crabs, and other fauna.

Benthic sediments can range from soft, fine-grained clays to coarse-grained sands. In close proximity to the dredging activity, TSS concentrations would increase for the short term, but impacts would be negligible in the surrounding area. Any upstream and downstream transport would be localized and would be below levels that would affect normal life functions of benthic invertebrates. Thus, impacts to benthic habitat due to TSS would be minimal, if any.

Approximately 7.6 acres of sediment dredging area is targeted for removal and backfill that could potentially impact benthic habitat/food sources for during the construction period of October to February. Although some habitat disruption will occur during this timeframe, the long-term benefit will be gained by reducing areas of sediments known to contain potentially ecologically-threatening constituents. It is anticipated that restoration of the dredged areas with clean backfill materials, along with natural sedimentation processes will allow for the re-colonization of native benthic communities. Similarly, natural sedimentation will occur on the cap, which will also allow for the re-colonization of native benthic communities. The re-colonization of the benthic community within the dredge area substrates will provide benthic habitat and food sources.

To further minimize the potential impacts of the remediation activities, as discussed below in Section 8, the dredging will occur during times of the year when bottom feeders are unlikely to be present in the dredging area. In addition, the dredge area (approximately 7.6 acres) and capping area (approximately 2.5 acres) is relatively small (less than 1%) as compared to the overall sediment surface within the Hudson River that provides benthic habitat.

6.3 Submerged Aquatic Vegetation and Significant Coastal Fish and Wildlife Habitats

6.3.1 Submerged Aquatic Vegetation

No submerged aquatic vegetation (SAV) beds have been observed to occur along the shoreline of the dredge prisms. Moreover, much of the dredge area is below 40 feet in depth, where SAV would not occur due to light attenuation. It is expected that little, if any, impact would occur to SAV beds due to sediment suspension or deposition.

6.3.2 Significant Coastal Fish and Wildlife Habitats

The Kingston-Poughkeepsie Deepwater habitat has been designated as a SCFWH by the NYSDEC. Any activity that would substantially degrade water quality, increase turbidity or sedimentation, alter flows, salinity, or temperature, reduce water depths, or degrade or alter benthic communities in Kingston-Poughkeepsie Deepwater would result in significant impairment of the habitat (NYSDEC, 2012). Any physical alteration of the habitat through dredging or filling would result in a direct loss of valuable habitat. Such activities could have significant impacts on striped bass and sturgeon populations during spawning, and incubation periods (May-July, primarily) and overwintering times. Habitat disturbances would be most detrimental during fish spawning and nursery periods, which generally extend from April through August for most warm water species.

Dredging activities within the SCFWH area are limited to approximately 25,000 CYs within approximately 4 acres. Turbidity beyond the dredging area will be controlled by using an environmental bucket within a containment cell which will be outfitted with turbidity curtains that extend to the river bottom and floating booms on all sides. In addition, because dredging activities are anticipated to be conducted between October and February and less intrusive capping activities between July and September, any disturbances to habitat that would occur due to sedimentation will be short term and minor. Moreover, the removal of sediments known to contain potentially ecologically-threatening constituents would provide long-term benefits to the fauna of the deepwater habitat which transit through the Hudson River.

6.4 Fish

Fish populations in the Hudson River are dynamic and change with the seasons. Several species of fish are present year round; however, many species only occur during the warmer months of the year or during migration periods in the spring and fall.

Resuspension of estuarine sediments have variable impacts on fish depending on species and life stage. Lethal levels of water column solids vary widely among species; one study found that the tolerance of adult fish for suspended sediment ranged from 580 milligrams per liter (mg/L) to 24,500 mg/L (Shrek et al. 1975 as cited in NMFS, 2003). Common impacts to fish are the abrasion of gill membranes (resulting in inability to collect oxygen), impairment of feeding, reduction in dissolved oxygen, and fatal impacts to early life stages. Increased TSS can inhibit migratory movements as well. A study conducted in 1976 determined that TSS concentrations as low as 350 mg/L blocked upstream migrations (NOAA 2001).

Larval stage fish also have a wide suspended sediment tolerance ranges; however, the reported data is generally thought to represent tolerance levels for only relatively short exposure periods (e.g., <24 hours) (Morgan and Levings, 1989). Beyond that timeframe, mortality can occur at concentrations as low as 1,300 mg/L (Morgan et al., 1983). Kiorboe et al. 1981, (as cited in Clarke and Wilber, 2000) indicates that hatching of striped bass and white perch can be delayed if daily sediment concentrations reach 100 mg/L. Wilbur and Clarke 2001 (as cited in NMFS, 2003), indicate that hatching is delayed for striped bass and white perch at concentrations of 800 and 100 mg/L, respectively.

When sediments are resuspended they disperse throughout the water column and also settle to the bed of the waterway within which construction is occurring. Impacts from deposited sediments can pose significant threats to aquatic organisms. For fish species, burial of eggs can result in mortality. Sediment deposition may have negative short-term impacts to adult and juvenile fish due to benthic habitat alterations and as a result of reduced foraging opportunities.

Fish species may be present within the dredging area during certain times of the year. Possible effects of the sediment dredging and capping on these species and their associated habitats include modified fish migration and feeding habits, as well as loss of eggs/larvae, habitat and/or food sources. However, the losses to the fish population are anticipated to be minimal. The presence of the turbidity curtain around the impacted sediments dredge areas, during the migration periods, may cause disturbances to fish for movement within the system.

Because the turbidity curtain installation and removal activities and dredging is anticipated to require approximately four months to complete, any effects on fish migration and feeding habits are anticipated to be temporary. Also, any juvenile or adult fish present within the remediation area are anticipated to be mobile and would likely avoid the dredge area during the turbidity curtain installation and removal, dredging and cap installation activities. Furthermore, the curtains will keep fish from entering the dredge areas during the remediation. Finally, as further discussed below in Section 8, BMPs and engineering controls, including conducting work when certain fish species are less likely to be present within the remediation area, will be implemented to minimize the potential for the dredging and capping activities to adversely affect fish migration and feeding habits.

Loss of eggs/larvae, habitat, and/or food sources may result from installation and securing of turbidity curtain anchoring devices placed around the dredge areas and during dredging activities. A small targeted area will be closed at a time and the turbidity curtain will be moved to the next dredge location as the sediment removal activities progress. Approximately 7.6 acres of sediment dredging area is targeted for removal, and backfill that could potentially impact fish eggs/larvae for approximately during the construction period of October to February. In addition, two areas above the underwater utility crossings

are targeted for capping (approximately one acre), and the side slope along the river will be graded and capped for stabilization (approximately 2.5 acres).

Due to the use of silt curtains and other BMPs, the water depths, and normal current speeds, it is anticipated that the TSS levels that would occur as a result of dredging operations will be considerably below the physiological thresholds of adult fish; moreover, dredging TSS levels are anticipated to be well below concentrations that would impact migration. Thus, it is anticipated that dredging during the timeframe (October through February) would be the least impactful to the river's ecological resources.

6.5 Essential Fish Habitat

It is anticipated the proposed project would have minimal, if any, effect on EFH or EFH species due to the temporary period of time when dredging would be conducted (anticipated from October 2018 through February 2019) and the small area that would be dredged (7.6 acres) and capped with mats (2.5 acres). Moreover, the proposed dredging would not occur during the key migratory spawning season (March 1 through June 30) and appropriate sediment containment devices (e.g., containment cells) would be employed to limit disturbance to adjacent aquatic environments during dredging and further reduce any potential impacts to EFH or EFH-managed species. Water quality (turbidity) will be monitored for the duration of the dredging by means of three buoy-mounted remote sensing stations that will be moored around the perimeter of the work area to confirm that the containment cell is functioning properly.

During construction, dredging, capping, and vessel activity may cause some fish resources to temporarily relocate from the project area with the result of decreased fish biomass in the project area. Many of the listed EFH species prefer saline environments and thus, due to the low salinities, it is likely that many of the EFH species listed would occur infrequently, if at all in the project area, or may be present in limited numbers during the warmer months of the year.

A benthic habitat comprised of finer-grained sediments is somewhat common in the Hudson River. The placement of clean sand and removal of the toxins associated with NAPL would have long-term benefits to the marine community. The placement of concrete mattresses and other hard surfaces would also result in topographic relief to the project area and provide a substrate for sessile organisms to colonize.

As such, disturbance to the habitat and benthic invertebrates would not result in significant impacts to EFH prey species' populations. Also, the waters of the Hudson River provide habitat to small baitfish, which some of the EFH species may feed upon. It is anticipated that any loss of baitfish individuals would be minimal and not jeopardize their regional populations, which would continue to be preyed upon by EFH species.

7. Endangered Species Concerns

Pursuant to Section 7 of the Endangered Species Act of 1973 (as amended), a request for project review was sent on November 10, 2017 to NOAA's NMFS Greater Atlantic Region Office. A subsequent response letter was received from the NOAA on November 16, 2017. Since endangered species (Atlantic sturgeons and shortnose sturgeons) are identified to be present near the work area, NOAA recommended considering using timing restriction for in-water work and use of best management practices to reduce effect for suspended sediments. Their comments are incorporated into the final design by limiting the dredge work window to October to February for dredge work and by designing a turbidity curtain that will reach all the way to the bottom of the dredge areas to minimize turbidity outside of the work area.

Additionally, a letter was sent to the USFWS New York Field Office. The subsequent response letter dated November 7, 2017 referenced their website listings for determining the species known to occur within the vicinity of the site. The letter mentioned the protection of bald eagles and guidance to minimize impact to the migratory bird species. Since work will be on and in the water, there will minimal impacts to surrounding areas that may be used by these birds. The letter also identified Indiana Bat (*Myotis sodalist*) (endangered species), Northern Long-eared Bat (*Myotis septentrionalis*) (threatened species) and Dwarf Wedgemussel (*Alasmidonta heterodon*) clams (endangered species) in the official species list. Because the project work will be done on the water, minimal impact to mammals is expected. An AECOM ecologist visited the site on December 11, 2017 to evaluate if there are any trees at the site that may be an important bat habitat. The clams and mussels identified in the list are typically found in freshwater streams, and not necessarily tidal portions of the Hudson River. Moreover, these species were not observed during the benthic sampling that occurred on site during December 2017. No critical habitats were identified in the project area under the jurisdiction of USFWS. The USFWS letter also identified the Atlantic sturgeon (*Acipenser oxyrinchus*) and shortnose sturgeon (*Acipenser brevirostrum*) (both endangered); impacts to these species are described above, in relation to oversight by NOAA.

Lastly, a letter was sent on November 10, 2017 to the NYSDEC New York Natural Heritage Program, part of the Division of Fish, Wildlife & Marine Resources. The subsequent response letter dated November 21, 2017 referenced the endangered shortnose sturgeon (*Acipenser brevirostrum*) and protected Atlantic sturgeon (*Acipenser oxyrinchus*) within the Hudson River, and nesting peregrine falcons (*falco peregrinus*) within a half-mile of the site. However, the project will be conducted on and in the water and will not affect the surrounding land areas and bridges nearby, where peregrine falcons might be nesting.

Based on the available habitat within the remediation area in comparison to the habitat requirements of the listed species, it is anticipated that the Atlantic and shortnose sturgeon will likely utilize this habitat during a portion of their lifespan. Shortnose sturgeon have been documented in the Hudson River from the New York Harbor to the Troy Dam. From late fall to early spring, adult shortnose sturgeon concentrate in a few overwintering areas. Spawning adults concentrate just north of Kingston (RM 94) and non-spawning adults concentrate near Kingston and Haverstraw Bay. When water temperatures reach 8° C, typically in mid-April, reproductively active adults begin their migration upstream to the spawning grounds that extend from Troy to Coxsackie (RMs 149 to 118). Spawning typically occurs until water temperatures reach 15° C (generally from late April through May), after which adults disperse quickly downriver into their summer range. The broad summer range occupied by adult shortnose sturgeon

extends from approximately RM 24 to RM 110. Similar to non-spawning adults, most juveniles are distributed throughout the mid-river regions during the summer from approximately RM 24 to RM 91 and move back into the Haverstraw Bay region during the late fall. Recent information suggests that shortnose sturgeon are using the Lower Hudson River below RM 9, at least during the November to April time frame (NOAA 2008b).

Based on the shortnose and Atlantic sturgeon life cycles, with regard to spawning habitat and overwintering areas, it was concluded that the BMP would be to limit the dredge work window, install the turbidity curtain around the active dredge work area, and backfill the dredge area with clean sand during the timeframe when these species are less likely to be present in the site area (October through February), to avoid the overwintering near Kingston and the migration to the spawning grounds in conformance with the guidance received from the NOAA NMFS. The less intrusive capping over the utility crossings and side slope is proposed between July 2019 and September 2019, after the published key migratory spawning season (March 1 through June 30)

Given the size of the remediation area relative to the overall habitat (less than 1%) and timing of the proposed activities, potential disruption to the shortnose and Atlantic sturgeon appears to be insignificant.

8. Mitigation Activities

To minimize impacts to Hudson River during the implementation of the remedial activities, land-based and water-based BMPs will be implemented prior to the start of work. The BMPs are typical of the types of controls successfully used at other environmental remediation projects to minimize impacts to riverine systems. BMPs and engineering controls, including the containment cell, will be installed prior to the start of dredging activities and will be used throughout these activities accordingly. Additionally, dredged areas will be backfilled with clean sand imported from upland sources and transported to the site via barge. Dredged material will be dewatered at the site and shipped off-site for treatment and disposal.

8.1 Land-based Controls

Land-based erosion and sedimentation BMPs include the placement of staked straw bales and/or silt fences along the river bank and around disturbed areas; construction of stabilized construction entrances; and implementation of stormwater inlet protection (i.e., straw bales placed around stormwater inlets). The BMPs will be installed during site preparation activities and will be completed prior to any land disturbance or clearing activities as may be required for installation of the bulkhead replacement. Initial measures will be set up on the perimeter of the project site. Before material staging areas or temporary access roads are constructed, appropriate erosion and sedimentation control measures will be implemented around these areas. These BMPs will reduce erosion to the river, thereby reducing turbidity and oxygen demands, and protecting against siltation.

A site-specific Erosion and Sedimentation Control Plan (ESCP) has been prepared in accordance with the New York State Standards and Specifications for Erosion and Sediment Control. In accordance with the ESCP, a NYSDEC-qualified inspector will monitor the erosion and sedimentation control measures to verify that the control measures are operating as intended and to identify any control measures in need of repair. The designated NYSDEC-qualified inspector will monitor all erosion and sedimentation control devices at least once every 7 calendar days and maintain inspection results on-site. The control measures will be maintained throughout the course of the site construction activities, and following the completion of the site construction activities until the site has been fully stabilized. Maintenance requirements may include repairs or modifications, as needed, based on site conditions and planned remediation activities.

8.2 Water-based Controls

Water-based control measures will include performing the dredging work within containment (i.e. turbidity curtain), and implementing surface water and water column monitoring activities. These BMPs will monitor, control and isolate potential sediment, NAPL and sheen releases to the river, thereby reducing turbidity and oxygen demands and protecting against siltation. The BMPs are comprehensive, state of the art, and include types of controls successfully used at other environmental remediation projects to minimize impacts to riverine systems such as the Hudson River. The various BMPs include:

- Environmental Bucket: Targeted river sediments will be dredged using an environmental bucket, which is designed to provide flat dredge cuts for maximum control of the dredged surface while also utilizing seals to limit loss of material as the bucket is raised through the water column.

- **Turbidity Curtains:** Prior to the dredging of NAPL-impacted sediments, a turbidity curtain will be installed around the perimeter of the dredge areas. Absorbent booms will be installed in sediment dredging areas to contain the migration of any NAPL sheens that may be encountered during sediment removal activities. The turbidity curtain system will be inspected and maintained through the duration of sediment dredging activities.
- **Work Area Surface Water Monitoring:** Visual surface water monitoring will occur throughout the dredging and backfilling operation. Oil absorbent booms and/or pads will be used around all platforms and turbidity curtains to prevent migration of sheens outside of dredge areas. If NAPL/sheens are observed outside the turbidity curtain, the sheen will be chased and absorbed using absorbent booms and/or pads. The primary controls (turbidity curtains) and sorbent booms next to the curtains will be inspected and repaired or replaced as necessary to ensure their effectiveness in capturing sediments and NAPL/sheens.
- **Downstream Surface Water Monitoring:** A patrol boat, equipped with oil absorbent and containment booms, will be available downstream of the work area to visually inspect the surface water and mitigate any sheens observed.
- **Turbidity Monitoring:** A turbidity monitoring program will be performed during the sediment removal and restoration activities. Water quality (turbidity) will be monitored for the duration of the dredging by means of three buoy-mounted remote sensing stations that will be moored around the perimeter of the work area to confirm that the containment cell is functioning properly. Turbidity will be measured at an upstream location, a location near the work zone, and a downstream location within Hudson River.
- **Inspections:** Inspections of the water-based controls will be conducted each day at the beginning of removal activities. Inspections will also be conducted, as appropriate, in response to visible sediment plumes migrating from the work area or measured turbidity levels above the action level of 50 nephelometric turbidity units (NTUs) above the turbidity level at the upstream monitoring location. Inspections in response to turbidity levels above the action level metric will begin with a surface inspection using a boat. If the cause of the turbidity exceedance cannot be determined through surface inspection (i.e., no visible damage, breach, tear, or dislocation), a hand-held turbidity meter or other appropriate method will be used to identify the source. The Construction Quality Assurance Plan (CQAP) will identify contingency measures to meet turbidity action levels. Contingency measures may include modification to dredge operations (e.g., fall height, cycle time, bucket handling procedures, use of a rinse tank, etc.) or modifications or repairs of the containment systems.
- **Timing:** If required by Federal and/or State agencies, the remediation will be implemented during Federal and State-issued work windows for the protection of fish and wildlife habitats. Based on current information regarding potential presence, habitat, and life cycles of Atlantic sturgeon and shortnose sturgeon within this section of the river, the dredging activities will be conducted during the October to February timeframe and the less intrusive capping activities will be conducted from July to September. Further refinement of this timeframe will be considered and incorporated into the final design. This timing should minimize the level of disturbance not only for the shortnose sturgeon, but also to other species that may utilize the surrounding area for potential spawning or overwintering habitat.

Due to these measures and the temporary nature of the project, it is not anticipated that the proposed project will have a long-term adverse effect upon the habitat. Implementation of the proposed dredging will assist in improving the water quality, sediment quality, and benthic habitat in the Hudson River.

9. References

Applied Science Associates (ASA), Inc. 2006. Year Class Report for the Hudson River estuary monitoring program. Prepared for Dynegy Roseton L.L.C., Entergy Nuclear Indian Point L.L.C., Entergy Nuclear Indian Point L.L.C., and Mirant Bowline L.L.C.

Cooper, J.C., F.R. Cantelmo, and C.E. Newton. 1988. Overview of the Hudson River Estuary. American Fisheries Society Monograph 4: 11-24.

Geiser, John, 1984. A Comprehensive Guide to Saltwater Fishing Along the Northeast Coast (The Shore Catch). The Asbury Park Press, Inc., Neptune, NJ.

Heimbuch. 2008. Potential Effects of Striped Bass Predation on Juvenile Fish in the Hudson River. Transactions of the American Fisheries Society 137:1591-1605.

Hudson River Environmental Conditions Observing System (HRECOS), 2017. Website accessed for Marist Pump Station information. <http://www.hrecos.org/>; accessed December 14, 2017.

National Marine Fisheries Service, 2003. Endangered Species Act Biological Opinion for the National Pollutant Discharge Permit of the Washington Aqueduct F/NER/2003/00600

NOAA, 2017. Website accessed to identify EFH species near the project area. (<https://www.greateratlantic.fisheries.noaa.gov/hcd/ny3.html>; accessed 6/8/2017)

NOAA, 2016. Tide Tables 2016 – East Coast of North and South America including Greenland. https://tidesandcurrents.noaa.gov/historic_tide_tables.html; Accessed December 2017.

NOAA Technical Memorandum NMFS-NE-137. Essential Fish Habitat Source Document: Windowpane, *Scophthalmus aquosus*, Life History and Habitat Characteristics. U. S. Department of Commerce. National Oceanic and Atmospheric Administration. National Marine Fisheries Service. Northeast Region. Northeast Fisheries Science Center. Woods Hole, Massachusetts. September 1999

NOAA Technical Memorandum NMFS-NE-149. Essential Fish Habitat Source Document: Scup, *Stenotomus chrysops*, Life History and Habitat Characteristics U. S. Department of Commerce. National Oceanic and Atmospheric Administration. National Marine Fisheries Service. Northeast Region. Northeast Fisheries Science Center. Woods Hole, Massachusetts. September 1999

NOAA Technical Memorandum NMFS-NE-151. Essential Fish Habitat Source Document: Summer Flounder, *Paralichthys dentatus*, Life History and Habitat Characteristics. U. S. Department of Commerce. National Oceanic and Atmospheric Administration. National Marine Fisheries Service. Northeast Region. Northeast Fisheries Science Center. Woods Hole, Massachusetts. September 1999

New York State Department of Environmental Conservation (NYSDEC), 2017. Website accessed for information on fish species in the Hudson River. (<http://www.dec.ny.gov/lands/97891.html>; accessed 11/15/17)

NYSDEC, 2005. Ecological Profile of the Hudson River National Estuarine Research Reserve. NYSDEC Contract No. C004646, December 2005.

New York State Department of State, Office of Planning and Development, 2012. Website accessed for information on Significant Coastal Fish & Wildlife Habitats.
<https://www.dos.ny.gov/opd/programs/consistency/scfwhabitats.html#hudson>; Accessed December 2017.

Pisces Conservation LTD. 2008. The Status of Fish Populations and the Ecology of the Hudson. Lymington, United Kingdom.

United States Fish and Wildlife Service (USFWS). 1997. *Significant Habitats and Habitat Complexes of the New York Bight Watershed*. Southern New England - New York Bight Coastal Ecosystem Program. Mid-Hudson River Estuary Complex #32. <http://nctc.fws.gov/resources/knowledge-resources/pubs5/begin.htm>; Accessed December 2017.

United States Geological Survey (USGS), 2017a. Internet site accessed for tide gage information at multiple sites as referenced in text. <http://waterdata.usgs.gov/nwis/rt>

USGS, 2017b. Website accessed for information regarding location of Hudson River Salt Wedge. https://ny.water.usgs.gov/projects/dialer_plots/hsfmis.html; accessed 11/13/2017. Wall, G.; Nystrom, E. & Simon, L. (2006), 'Use of an ADCP to Compute Suspended-Sediment Discharge in the Tidal Hudson River, New York'(Report 2006-5055), Technical report, U.S. Geological Survey.

APPENDIX A

Dredging Figures

File: P:\Jobs\Rem_Eng\Project Files\CHGE\900 CAD\910 CAD\20 SHEETS\PDF\Permitting 2\Permitting Figures.dwg Layout: VICINITY MAP User: erica.hart Plotted: Jan 11, 2018 - 10:06am Xref's:

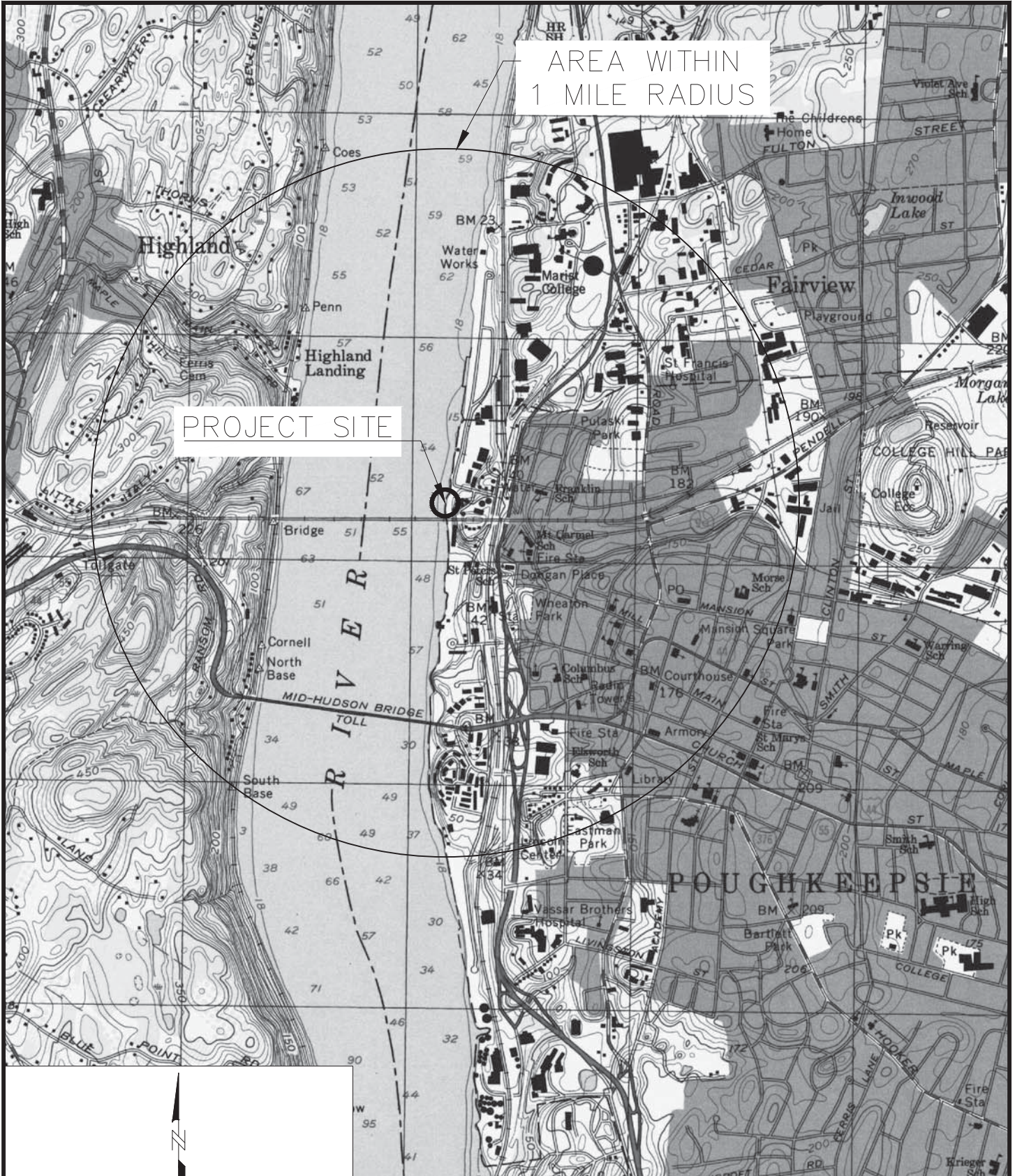

AREA WITHIN 1 MILE RADIUS

PROJECT SITE

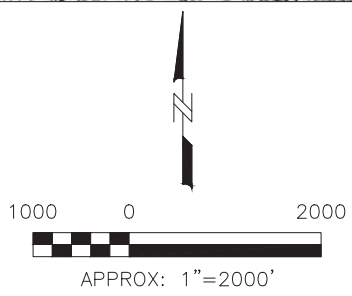

Map Source: U.S.G.S. 7.5' Quadrangle, Poughkeepsie, NY

For Agency Review Only



CENTRAL HUDSON GAS & ELECTRIC
HUDSON RIVER
DUTCHESS COUNTY, NY

VICINITY MAP
FORMER NORTH WATER STREET MGP
POUGHKEEPSIE

DATE: 1/11/18

FIGURE 1 OF 11

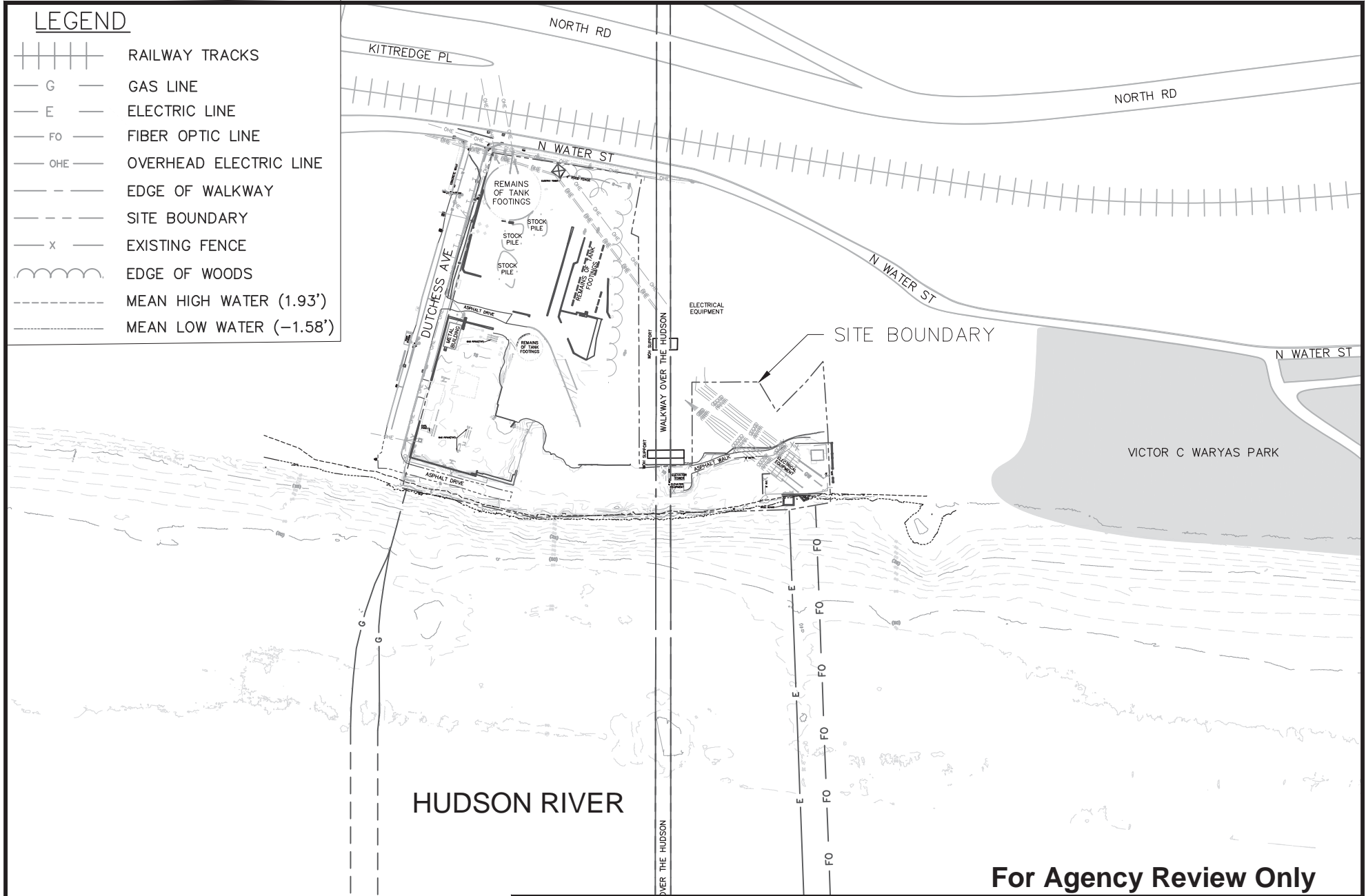

For Agency Review Only

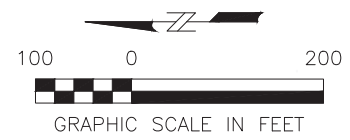

CENTRAL HUDSON GAS & ELECTRIC
HUDSON RIVER
DUTCHESS COUNTY, NY

DATE: 1/11/18

CURRENT SITE LAYOUT AND
KNOWN UTILITIES
FORMER NORTH WATER STREET MGP
POUGHKEEPSIE, NY

FIGURE 2 OF 11

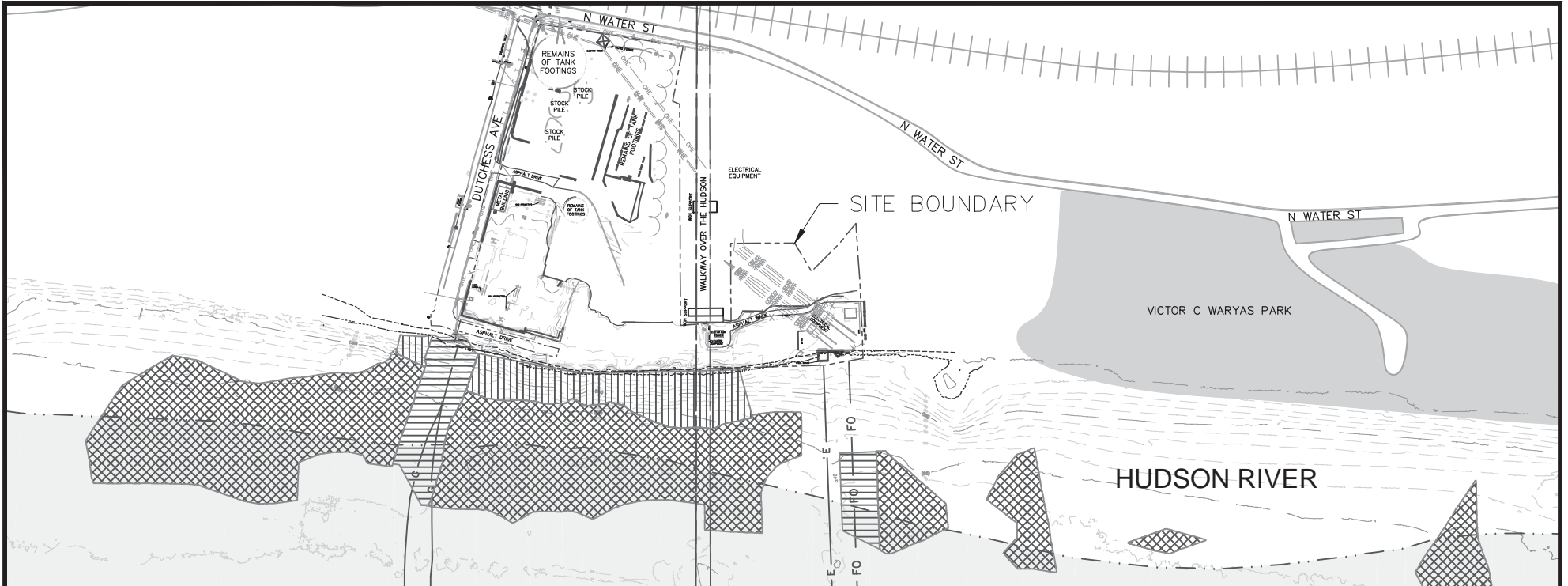

LEGEND

- | | | | |
|--|-------------------------|--|-----------------------------|
| | RAILWAY TRACKS | | |
| | GAS LINE | | PROPOSED SLOPE GRADING AREA |
| | ELECTRIC LINE | | PROPOSED UTILITY CAP AREA |
| | FIBER OPTIC LINE | | DREDGE AREA |
| | OVERHEAD ELECTRIC LINE | | |
| | EDGE OF WALKWAY | | |
| | SITE BOUNDARY | | |
| | EXISTING FENCE | | |
| | EDGE OF WOODS | | |
| | SCFWH AREA BOUNDARY | | |
| | MEAN HIGH WATER (1.93') | | |
| | MEAN LOW WATER (-1.58') | | |

KINGSTON-POUGHKEEPSIE DEEPWATER SCFWH AREA

For Agency Review Only

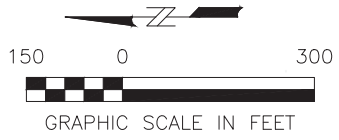

CENTRAL HUDSON GAS & ELECTRIC
 HUDSON RIVER
 DUTCHESS COUNTY, NY
 DATE: 1/11/18

REMEDIAL ACTIVITIES PLAN
 FORMER NORTH WATER STREET MGP
 POUGHKEEPSIE, NY
 FIGURE 3 OF 11

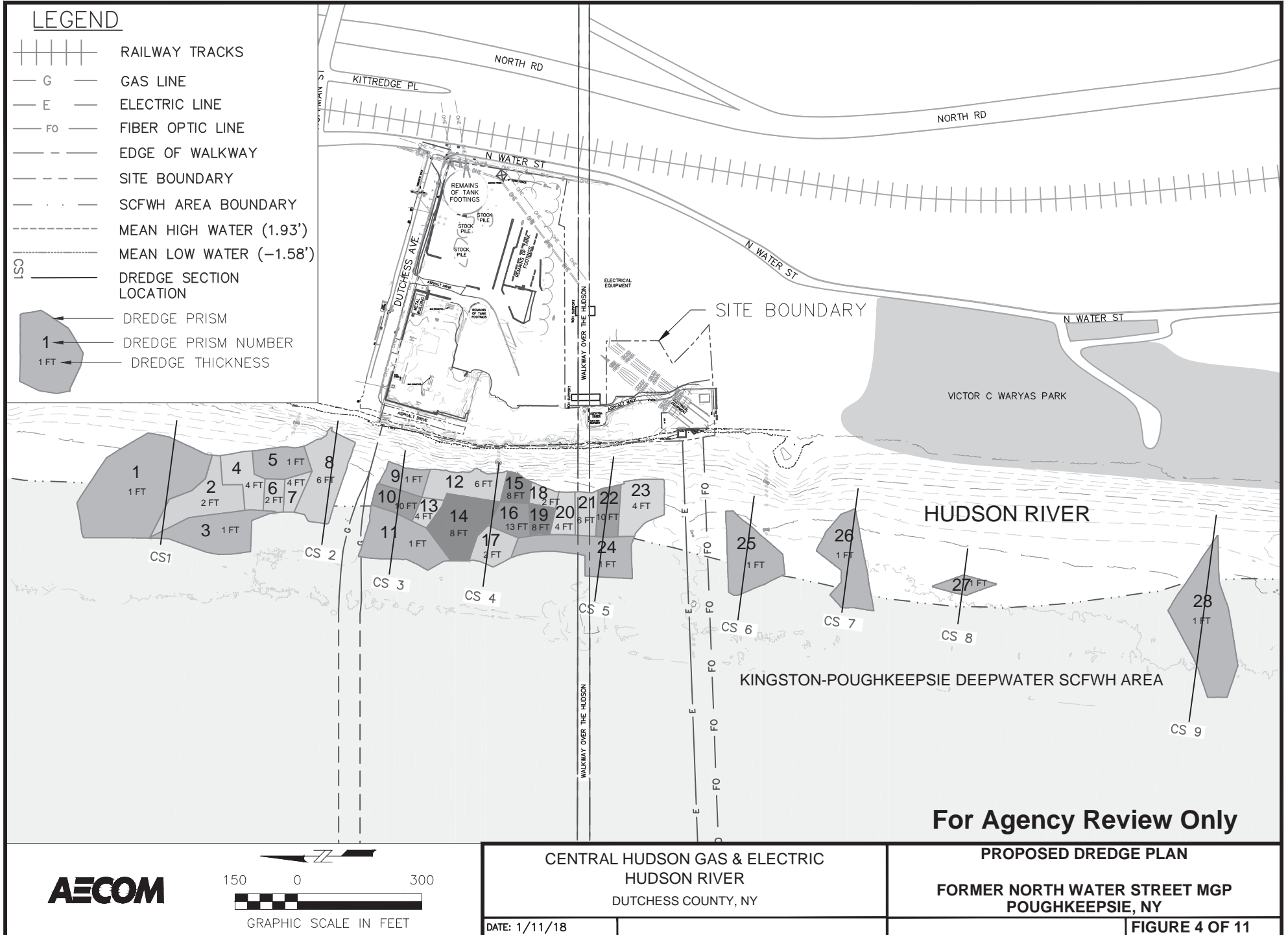

For Agency Review Only

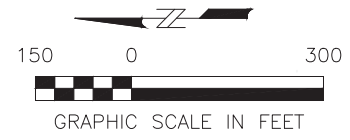

CENTRAL HUDSON GAS & ELECTRIC
 HUDSON RIVER
 DUTCHESS COUNTY, NY
 DATE: 1/11/18

PROPOSED DREDGE PLAN
 FORMER NORTH WATER STREET MGP
 POUGHKEEPSIE, NY
 FIGURE 4 OF 11

DREDGE SECTION 2

DREDGE SECTION 1

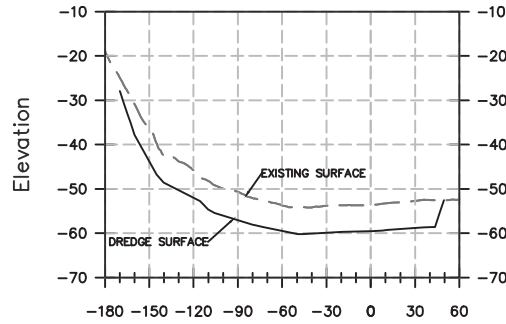
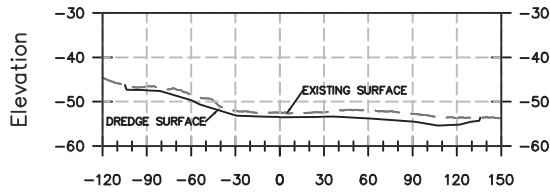

DREDGE SECTION 3

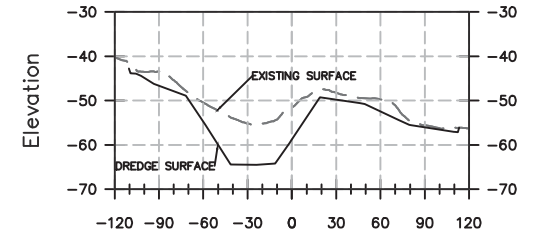

DREDGE SECTION 4

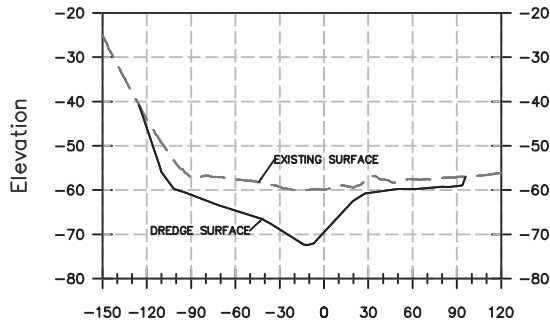

DREDGE SECTION 5

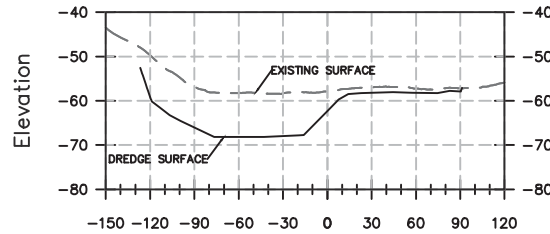

DREDGE SECTION 6

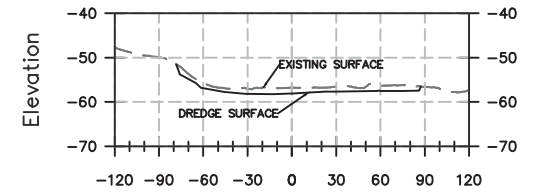

DREDGE SECTION 7

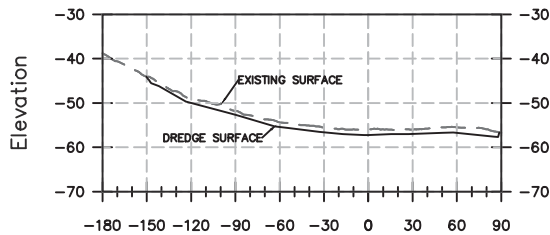

DREDGE SECTION 8

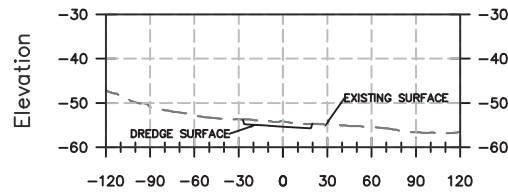

DREDGE SECTION 9

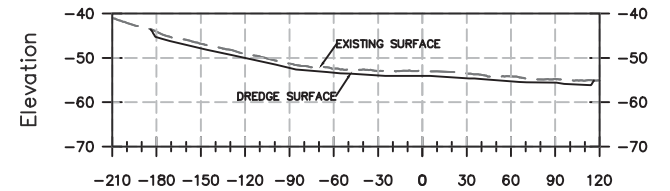

For Agency Review Only



CENTRAL HUDSON GAS & ELECTRIC
HUDSON RIVER
DUTCHESS COUNTY, NY

PROPOSED DREDGE PLAN
CROSS SECTIONS
FORMER NORTH WATER STREET MGP
POUGHKEEPSIE, NY

DATE: 1/11/18

FIGURE 5 OF 11

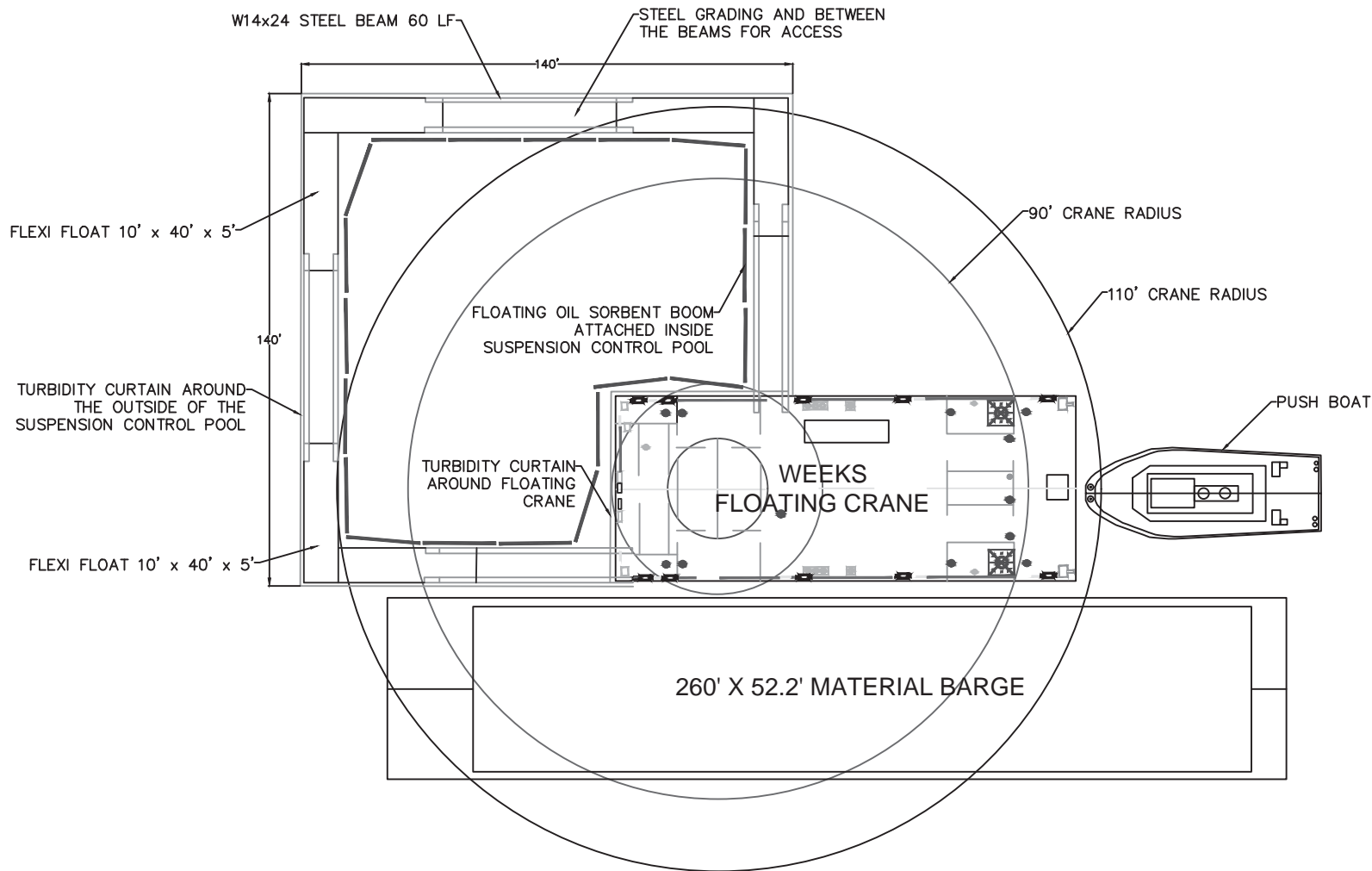

MOBILE SUSPENSION CONTROL SYSTEM SETUP OVERVIEW

NOTE: FIGURES NOT DRAWN TO SCALE. THESE ARE CONCEPTUAL DRAWINGS.

For Agency Review Only



CENTRAL HUDSON GAS & ELECTRIC
HUDSON RIVER
DUTCHESS COUNTY, NY

ENGINEERING CONTROLS
PLAN VIEW
FORMER NORTH WATER STREET MGP
POUGHKEEPSIE, NY

DATE: 1/11/18

FIGURE 6A OF 11

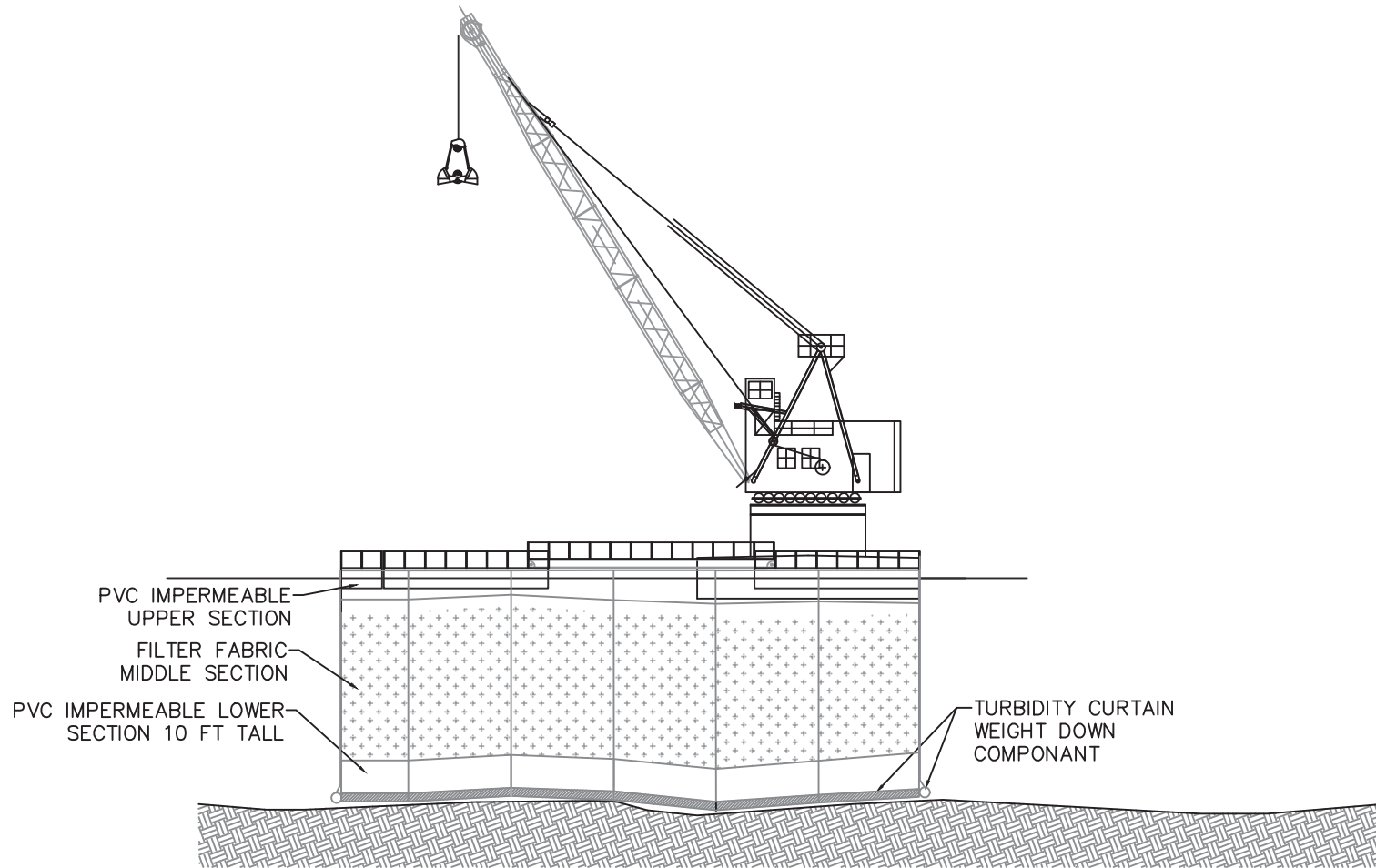

MOBILE SUSPENSION CONTROL SYSTEM SETUP
FRONT VIEW

NOTE: FIGURES NOT DRAWN TO SCALE. THESE ARE CONCEPTUAL DRAWINGS.

For Agency Review Only



CENTRAL HUDSON GAS & ELECTRIC
HUDSON RIVER
DUTCHESS COUNTY, NY

ENGINEERING CONTROLS
SIDE VIEW
FORMER NORTH WATER STREET MGP
POUGHKEEPSIE, NY

DATE: 1/11/18

FIGURE 6B OF 11

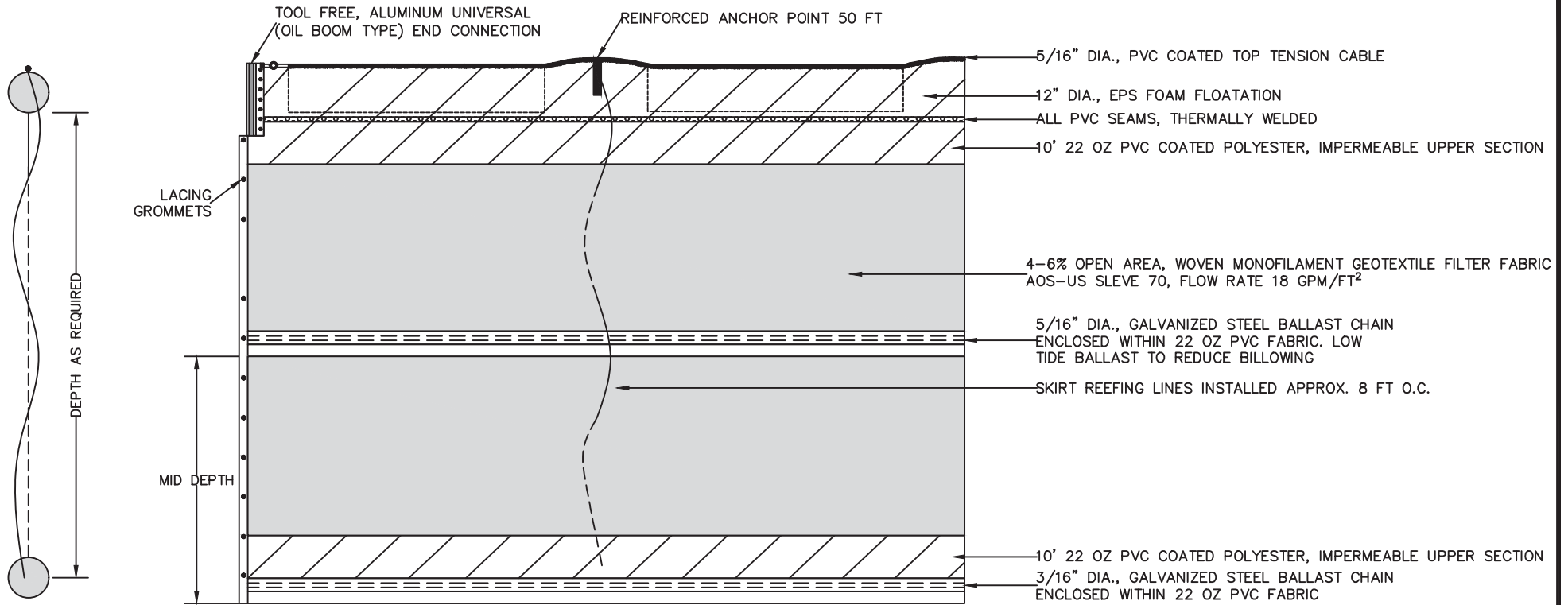

TURBIDITY BARRIER DETAIL

NOTE: FIGURES NOT DRAWN TO SCALE. THESE ARE CONCEPTUAL DRAWINGS.

For Agency Review Only



CENTRAL HUDSON GAS & ELECTRIC
HUDSON RIVER
DUTCHESS COUNTY, NY

ENGINEERING CONTROLS
DETAIL
FORMER NORTH WATER STREET MGP
POUGHKEEPSIE, NY

DATE: 1/11/18

FIGURE 6C OF 11

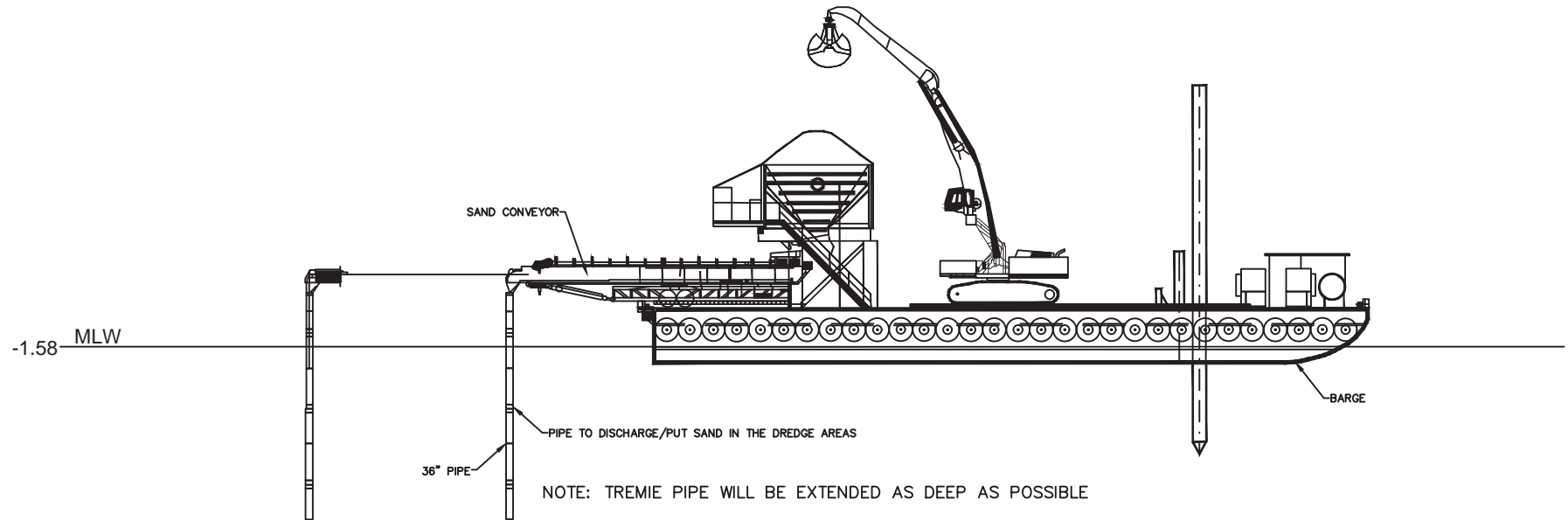

CONCEPTUAL DREDGE RESTORATION OPERATION

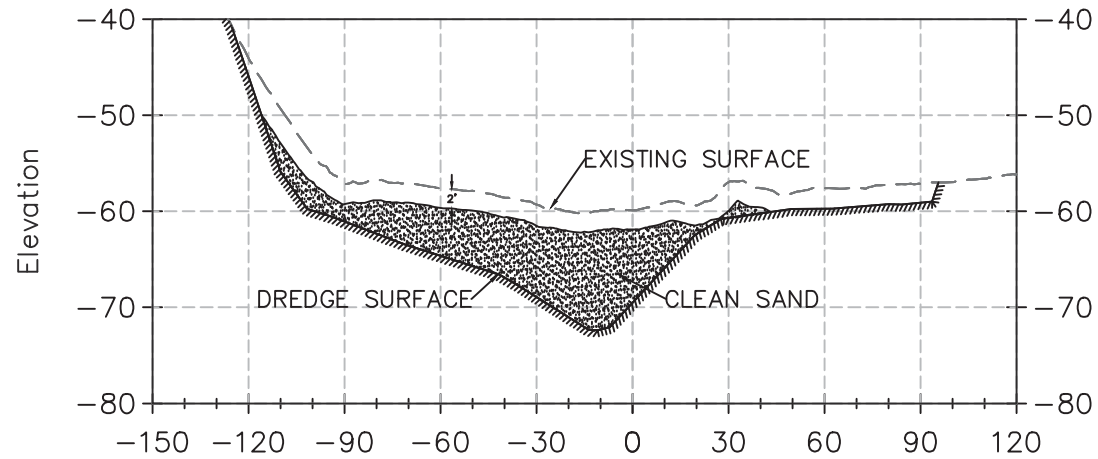

For Agency Review Only



CENTRAL HUDSON GAS & ELECTRIC
HUDSON RIVER
DUTCHESS COUNTY, NY



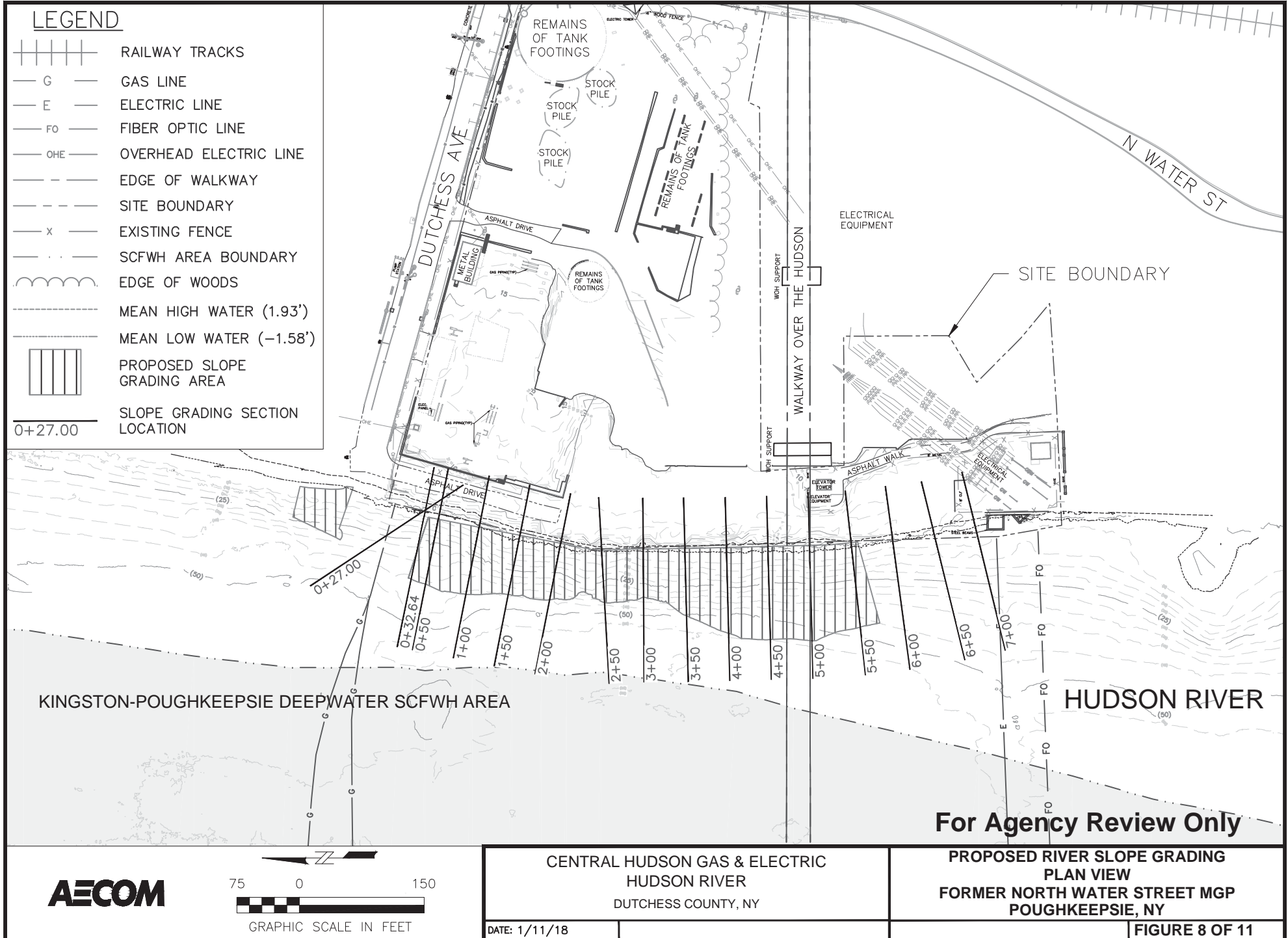

DREDGE AREA RESTORATION PLAN
FORMER NORTH WATER STREET MGP
POUGHKEEPSIE, NY

DATE: 1/11/18

FIGURE 7 OF 11

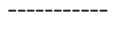

LEGEND

-  ORIGINAL SLOPE SURFACE
-  RESTORED CAP SURFACE
-  DREDGE SURFACE
-  MEAN HIGH WATER (1.93')
-  MEAN LOW WATER (-1.58')

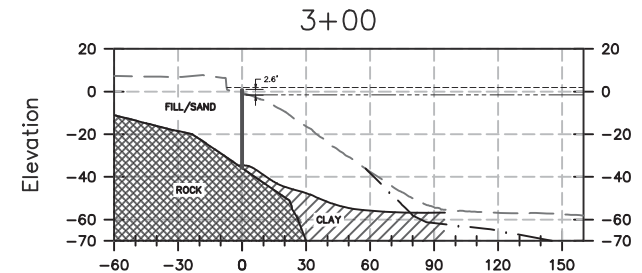
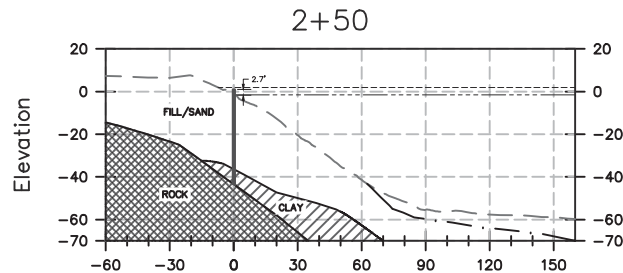
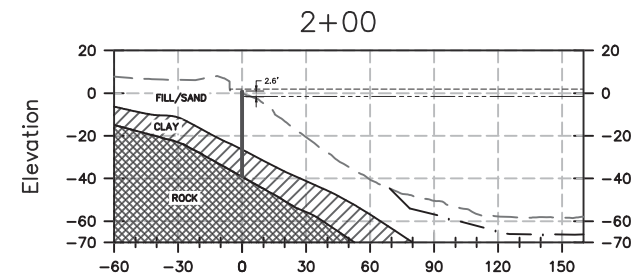
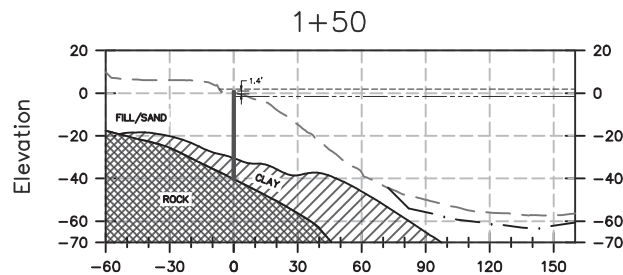
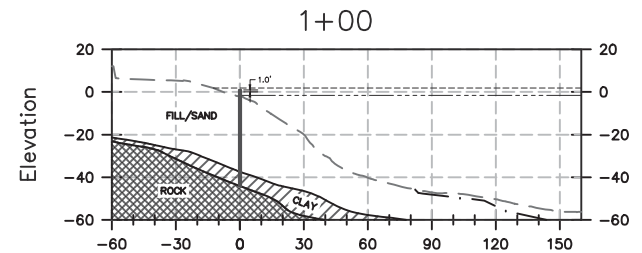
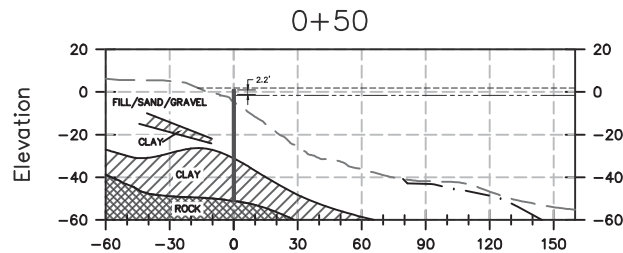
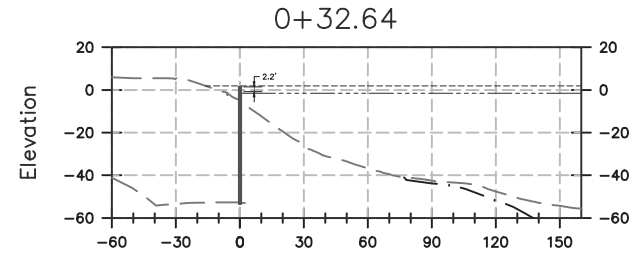
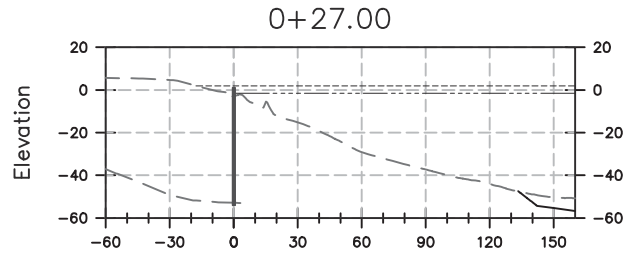

For Agency Review Only



CENTRAL HUDSON GAS & ELECTRIC
HUDSON RIVER
DUTCHESS COUNTY, NY

PROPOSED RIVER SLOPE GRADING
CROSS SECTIONS
FORMER NORTH WATER STREET MGP
POUGHKEEPSIE, NY

DATE: 1/11/18

FIGURE 9A OF 11

LEGEND

- ORIGINAL SLOPE SURFACE
- RESTORED CAP SURFACE
- . - . DREDGE SURFACE
- - - - - MEAN HIGH WATER (1.93')
- MEAN LOW WATER (-1.58')

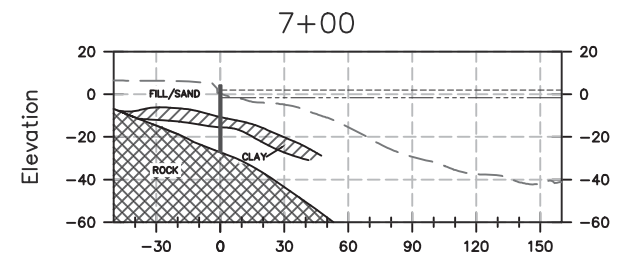
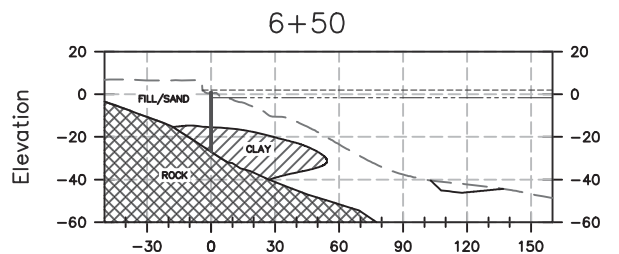
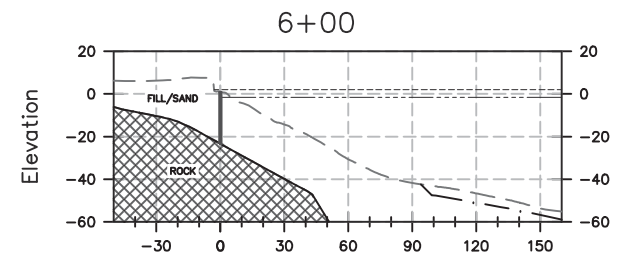
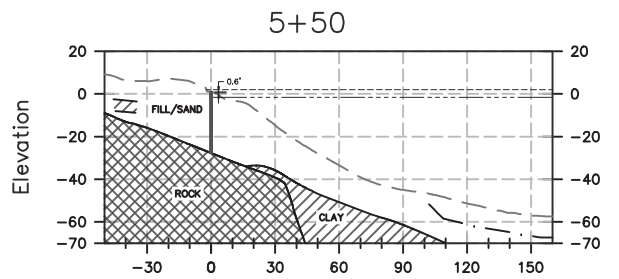
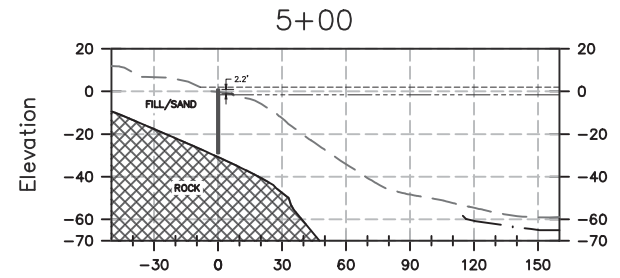
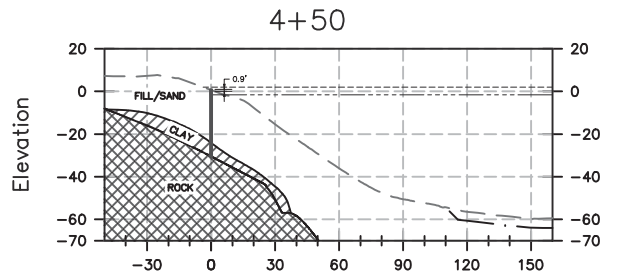
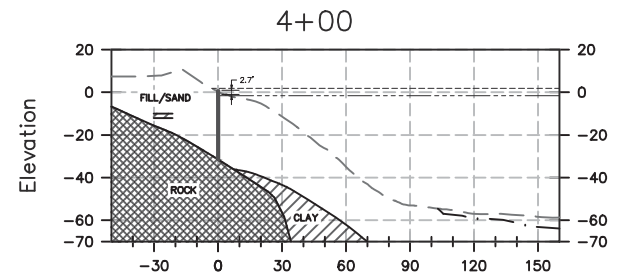
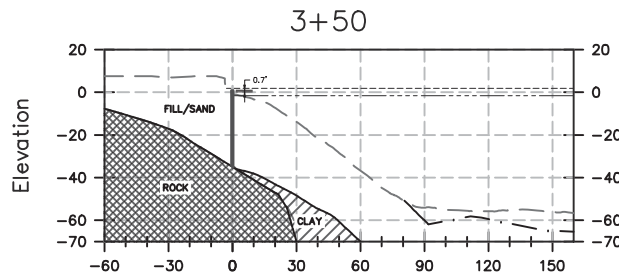

For Agency Review Only



CENTRAL HUDSON GAS & ELECTRIC
HUDSON RIVER
DUTCHESS COUNTY, NY

PROPOSED RIVER SLOPE GRADING
CROSS SECTIONS
FORMER NORTH WATER STREET MGP
POUGHKEEPSIE, NY

DATE: 1/11/18

FIGURE 9B OF 11

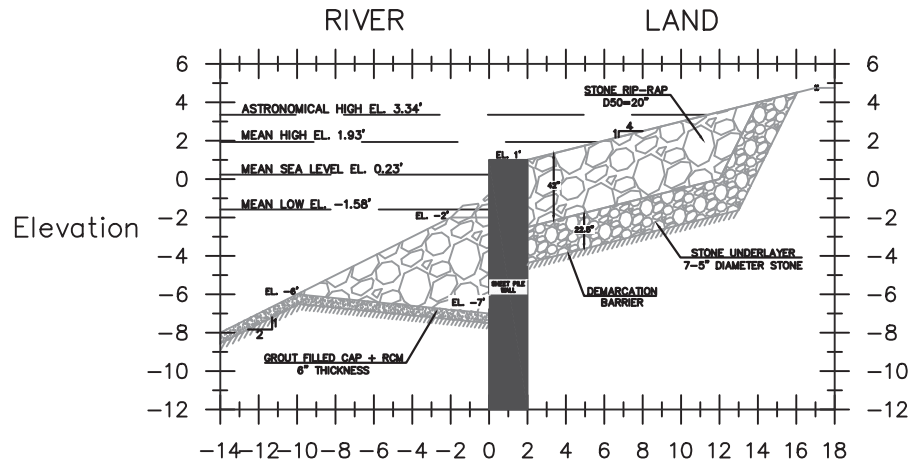

PROPOSED SIDE SLOPE RESTORATION

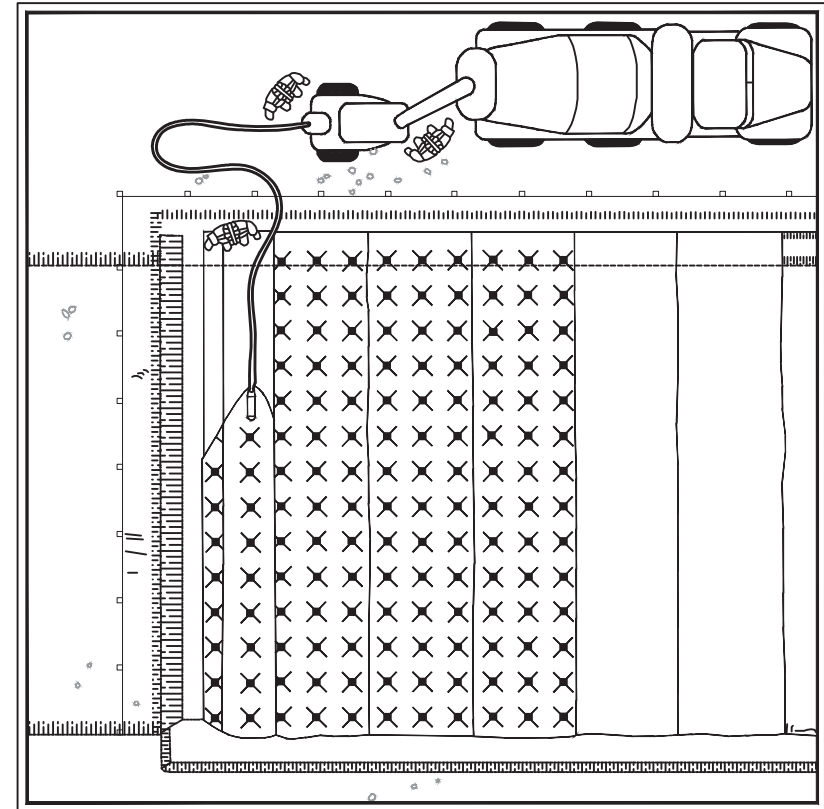

REACTIVE CORE MAT OVERLAID WITH CONCRETE MATTRESSES
ISOMETRIC VIEW

For Agency Review Only



CENTRAL HUDSON GAS & ELECTRIC
HUDSON RIVER
DUTCHESS COUNTY, NY

DETAILS FOR SIDE SLOPE CAP
FORMER NORTH WATER STREET MGP
POUGHKEEPSIE, NY

DATE: 1/11/18

FIGURE 10 OF 11

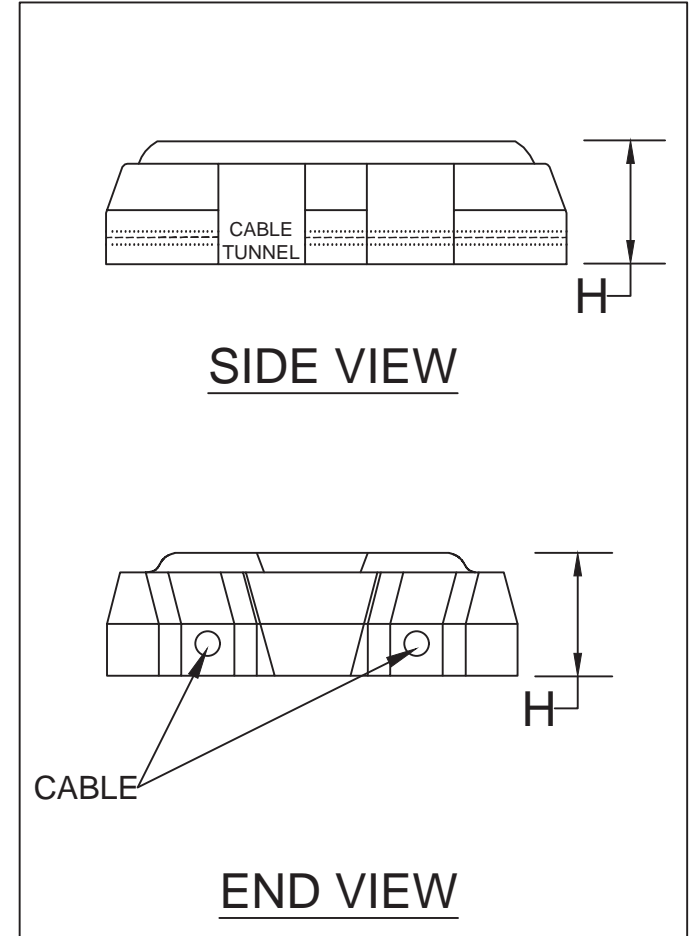
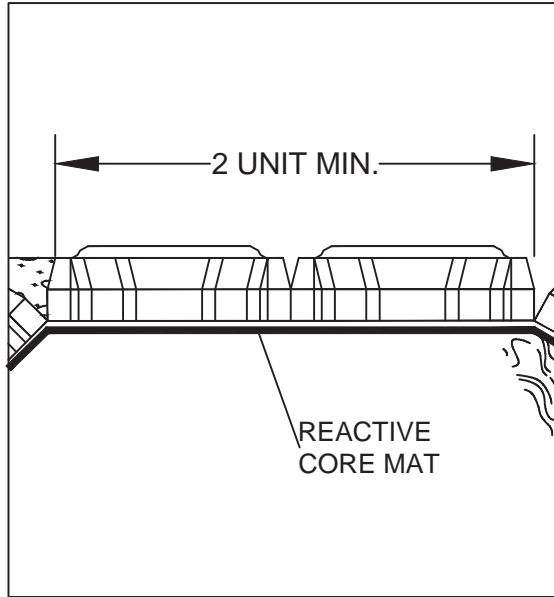
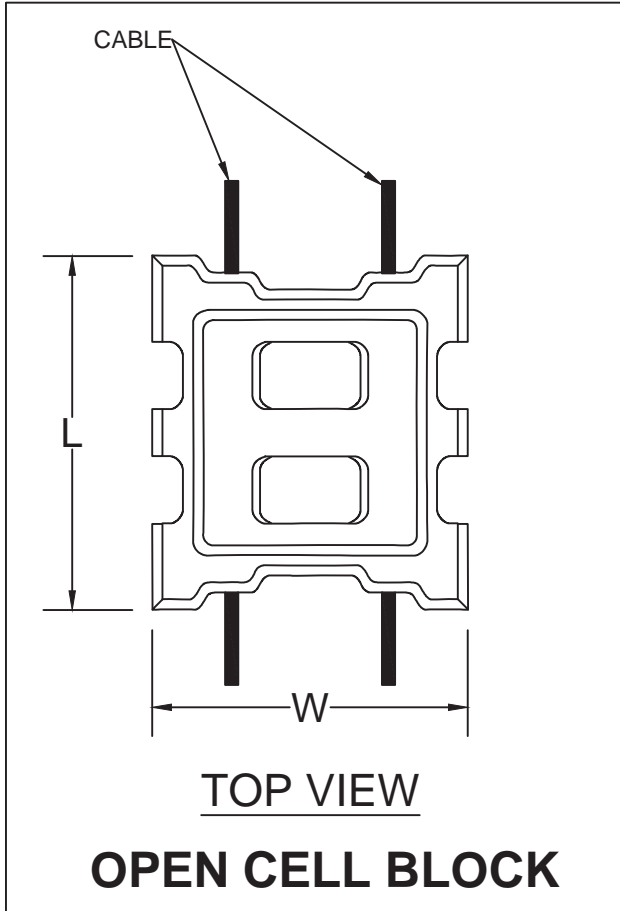

For Agency Review Only



CENTRAL HUDSON GAS & ELECTRIC
HUDSON RIVER
DUTCHESS COUNTY, NY

DETAILS FOR UTILITY CAP
FORMER NORTH WATER STREET MGP
POUGHKEEPSIE, NY

DATE: 1/11/18

FIGURE 11 OF 11

APPENDIX B

Product Description Sheets – Slope Stabilization Material

REACTIVE CORE MAT™

WITH ORGANOCLAY®

DESCRIPTION

ORGANOCLAY® REACTIVE CORE MAT™ is a permeable composite of geotextiles and granular ORGANOCLAY that reliably adsorbs NAPL and low solubility organics from water. Batch isotherm testing by a university determined the following partition coefficients:

- Naphthalene, Kd = 3280 L/kg
- Phenanthrene, Kd = 117,000 L/kg
- Pyrene, Kd - 286,000 L/kg

APPLICATION

ORGANOCLAY® REACTIVE CORE MAT™ is designed for use in the following applications:

- In situ subaqueous cap for contaminated sediments or post-dredge residual sediments
- Embankment seepage control
- Groundwater remediation

BENEFITS

- ORGANOCLAY® REACTIVE CORE MAT™ provides a reactive material that treats contaminants carried by advective/diffusive flow
- Reactive cap allows for thinner cap thickness than a traditional sand cap
- Geotextiles provide stability and physical isolation of contaminants

AVAILABILITY

ORGANOCLAY® REACTIVE CORE MAT™ is available from the following CETCO plant locations:

- 92 Highway 37, Lovell, WY



REACTIVE CORE MAT™ is designed to provide a simple method of placing active materials into subaqueous sediment caps.

PACKAGING

15' by 100' rolls, packaged on 4" PVC core tubes wrapped with polyethylene plastic packaging.

TESTING DATA

PHYSICAL PROPERTIES		
PROPERTY	TEST METHOD	RESULT
ORGANOCLAY¹		
Bulk Density Range	ASTM D 7481	44 - 56 lbs/ft ³
Oil Adsorption Capacity	CETCO Test Method	0.5 lb of oil per lb of ORGANOCLAY, min
Quaternary Amine Content	ASTM D 7626	25 - 33% quaternary amine loading
FINISHED RCM PRODUCT		
ORGANOCLAY Mass per Area	CETCO Test Method	0.8 lb/ft ²
Mat Grab Strength ²	ASTM D4632	90 lbs. MARV
Hydraulic Conductivity ³	ASTM D4491	1 x 10 ⁻³ cm/sec minimum

NOTES:

¹ ORGANOCLAY properties performed periodically on material prior to incorporation into the RCM

² All tensile testing is performed in the machine direction

³ Permittivity at constant head of 2 inches and converted to hydraulic conductivity using Darcy's Law and RCM thickness per ASTM D5199 for geotextiles

North America: 847.851.1800 | 800.527.9948 | www.CETCO.com

© 2014 CETCO. IMPORTANT: The information contained herein supersedes all previous printed versions, and is believed to be accurate and reliable. For the most up-to-date information, please visit www.CETCO.com. CETCO accepts no responsibility for the results obtained through application of this product. CETCO reserves the right to update information without notice.

UPDATED: NOVEMBER 2013

TDS_RCM-ORGANOCLAY_AM_EN_201311_v1



Armortec Product Details

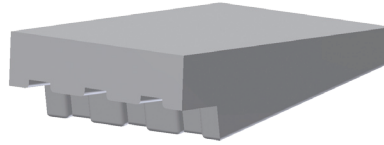

ArmorWedge[®]

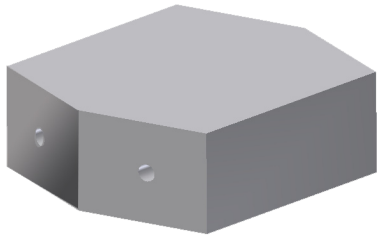

ArmorRoad[®]

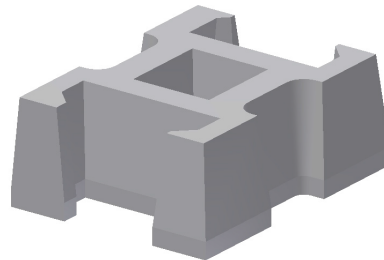

ArmorLoc[®]

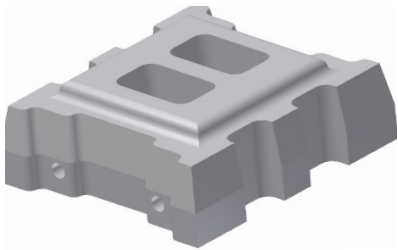

ArmorFlex[®] - Open Cell

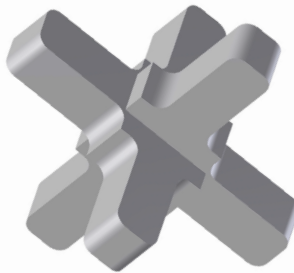

A-Jacks[®]

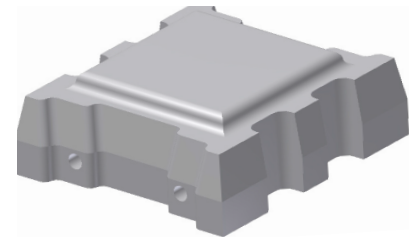

ArmorFlex[®] - Close Cell

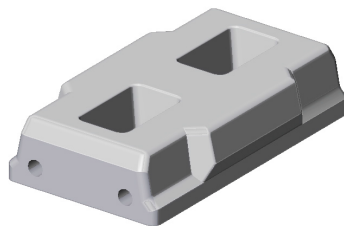

ArmorStone[®]

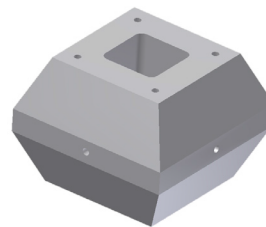

ArmorFlex[®] OS

MANUFACTURING SPECIFICATION
ASTM D6684-04

ArmorFlex® (not to scale)

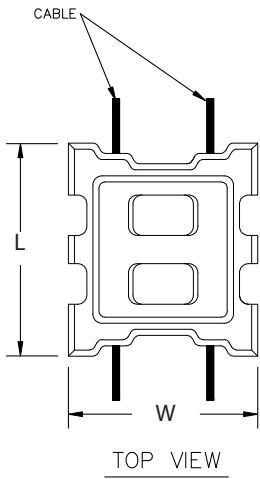

Open Cell Block

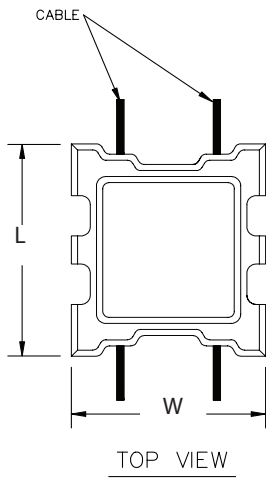

Close Cell Block

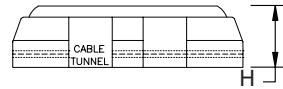

SIDE VIEW

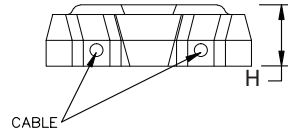

END VIEW

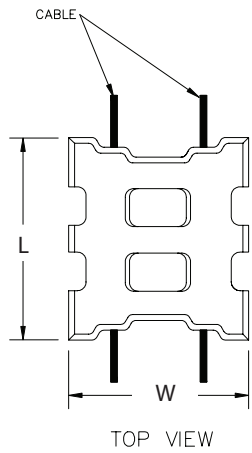

Tapered Series

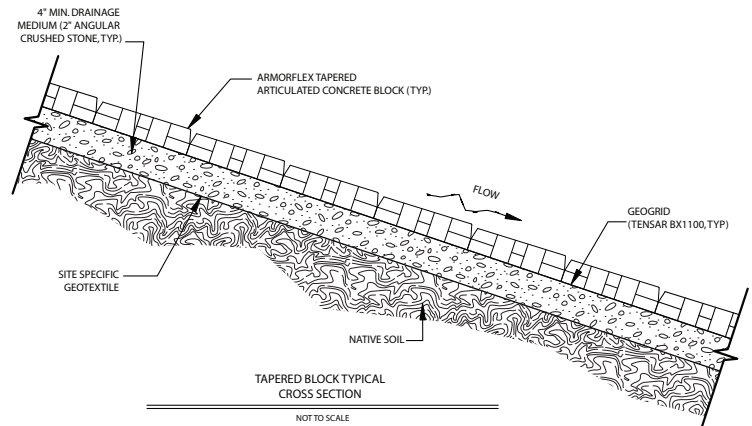
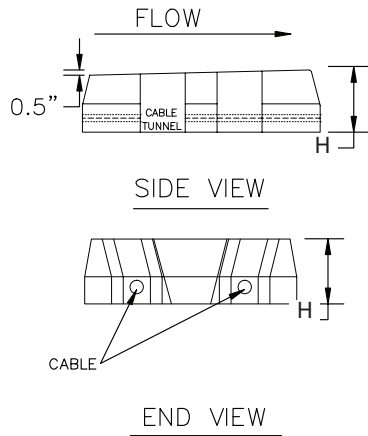

Tapered Series - Cross Section

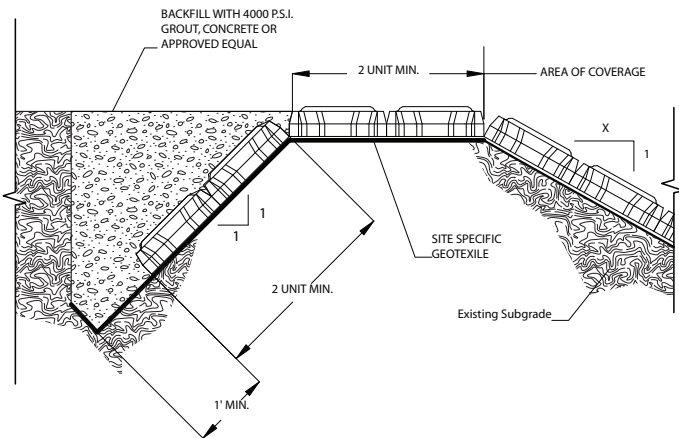

Top of Slope - Standard Detail

ArmorFlex Unit Specification

Concrete Block Class	Open/Closed Cell	Nominal Dimensions			Gross Area/ (sq. ft.)	Block Weight		Open Area %
		L	W	H		lbs	lbs/sq. ft.	
30s	Open	13.0	11.6	4.75	0.98	31-36	32-37	20
50s	Open	13.0	11.6	6.00	0.98	45-52	45-53	20
40	Open	17.4	15.5	4.75	1.77	62-71	35-40	20
50	Open	17.4	15.5	6.00	1.77	81-94	46-53	20
70	Open	17.4	15.5	8.50	1.77	120-138	68-78	20
40L	Open	17.4	23.6	4.75	2.58	90-106	35-41	20
70L	Open	17.4	23.6	8.50	2.58	173-201	67-78	20
45s	Closed	13.0	11.6	4.75	0.98	39-45	40-45	10
55s	Closed	13.0	11.6	6.00	0.98	53-61	54-62	10
45	Closed	17.4	15.5	4.75	1.77	78-89	43-50	10
55	Closed	17.4	15.5	6.00	1.77	94-108	53-61	10
85	Closed	17.4	15.5	8.50	1.77	145-167	82-98	10
45L	Closed	17.4	23.6	4.75	2.58	108-126	42-49	10
85L	Closed	17.4	23.6	8.50	2.58	209-243	81-94	10

High Velocity Application Block Classes

40-T	Open	17.4	15.5	4.75	1.77	62-71	35-40	20
50-T	Open	17.4	15.5	6.00	1.77	81-94	46-53	20
70-T	Open	17.4	15.5	8.50	1.77	120-138	68-78	20

ArmorFlex® cont. (not to scale)

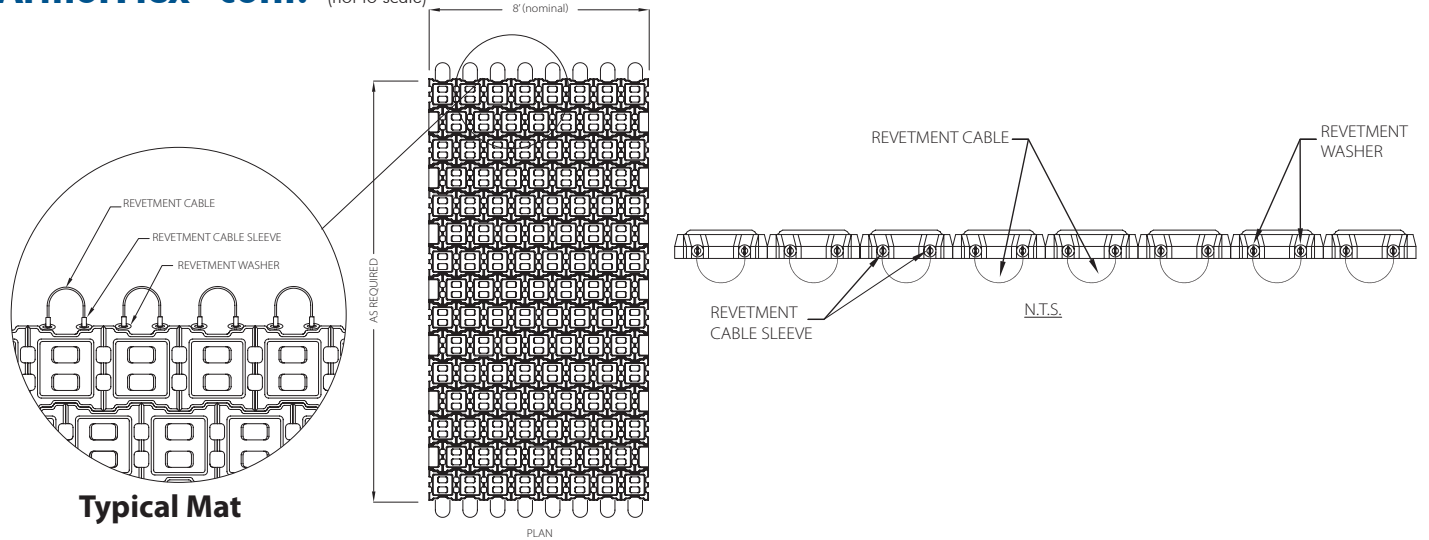

A-Jacks® (not to scale)

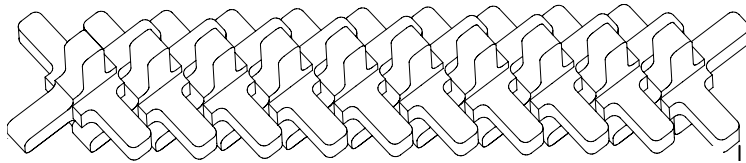

A-Jacks Placement Profile

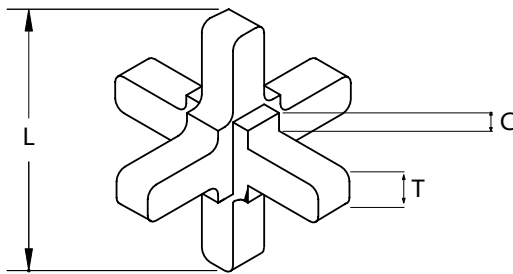

A-Jacks Unit

A-Jacks Unit Specification

A-JACKS	L(IN)	T(IN)/H(IN)	C(IN)	VOL(FT³)	WT (LBS)
AJ-24	24	4	1.84	0.56	78
AJ-48	48	7.36	3.68	4.49	629
AJ-72	72	11.04	5.52	15.14	2.120
AJ-96	96	14.72	7.396	35.87	5.022
AJ-120	120	18.40	9.20	70.69	9.699

ArmorWedge® (not to scale)

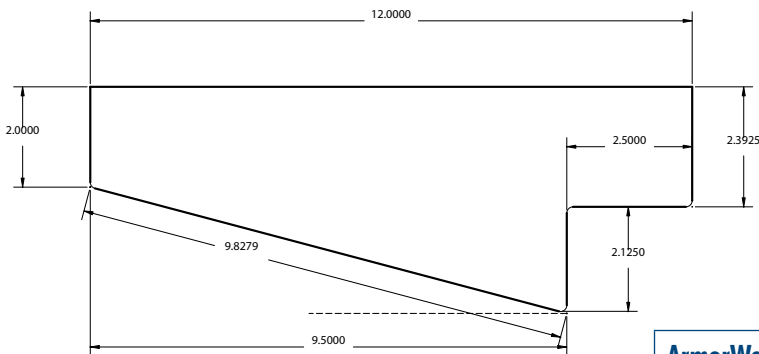

Side View - Typical Block

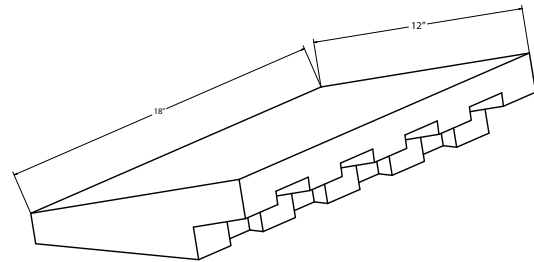

ArmorWedge Unit Specification

UNIT DIMENSION	UNIT WEIGHT (LBS)	SYSTEM WEIGHT (LBS)	UNIT COVERAGE (SF)	COMPRESSIVE STRENGTH (PSI)	MAXIMUM ABSORPTION (LBS/FT³)
12x18	40-52	36-40	1.1875	4000	12

ArmorLoc® (not to scale)

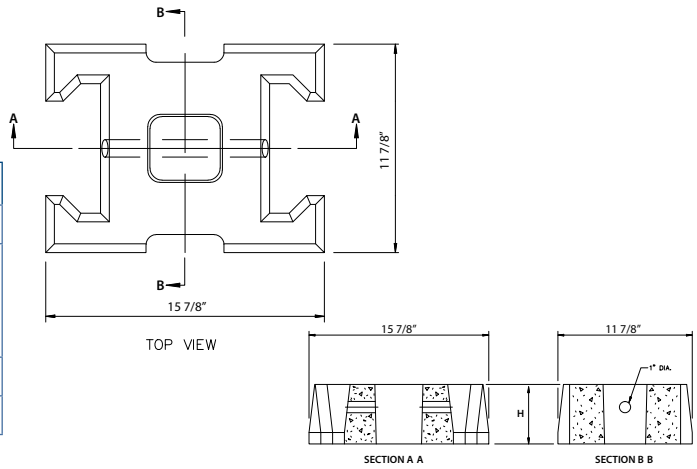

ArmorLoc Unit Specification

BLOCK	TECHNICAL DATA			DIMENSIONS AND WEIGHTS				
	Specific Weight lbs/ft ³	Compressive Strength psi	Max Absorption, Avg. of 3 units 10 lbs/ft ³	Thickness Inches (H)	Gross Area/ Grid ft ²	Weights/ Grid lbs	Weights/ Area lbs/ft ²	Open Area %
3510	130-150	4000 min	10	4	1.0	30-35	30-35	25
4511	130-150	4000 min	10	5.25	1.1	44-50	40-45	20

ArmorStone® (not to scale)

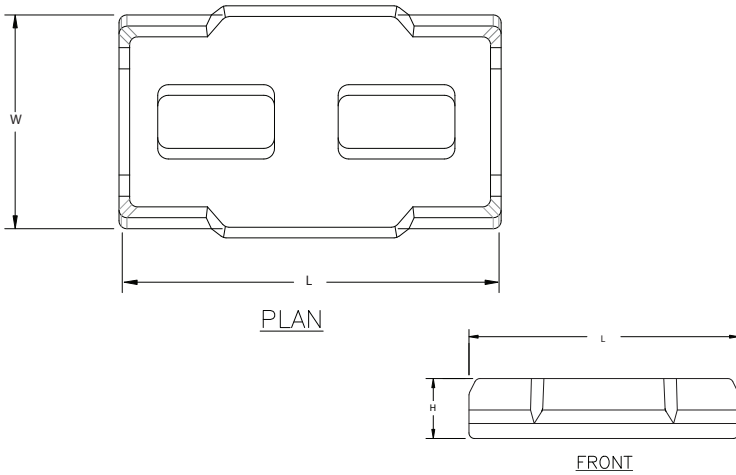

ArmorStone Unit Specification

CONCRETE BLOCK CLASS		NOMINAL DIMENSIONS (IN.)			UNIT COVERAGE (SF)	BLOCK		OPEN AREA %
		L	W	H		UNIT WEIGHT LBS.	SYSTEMS WEIGHTS LBS./SF	
AS 40	Open	18.00	10.00	4.50	1.25	50-54	40-44	25
AS 55	Closed	18.00	10.00	4.50	1.25	61-66	49-53	5

ArmorRoad® (not to scale)

ArmorRoad Unit Specification

BLOCK	TYPE	L	W	H	SF COVERAGE PER UNIT	WEIGHT LBS PER UNIT	SF PER TRUCK LOAD
Mat	Closed	18.00	15.60	6.00	1.74	105-109	750
Individual	Closed	18.00	15.60	6.00	1.74	100-104	750

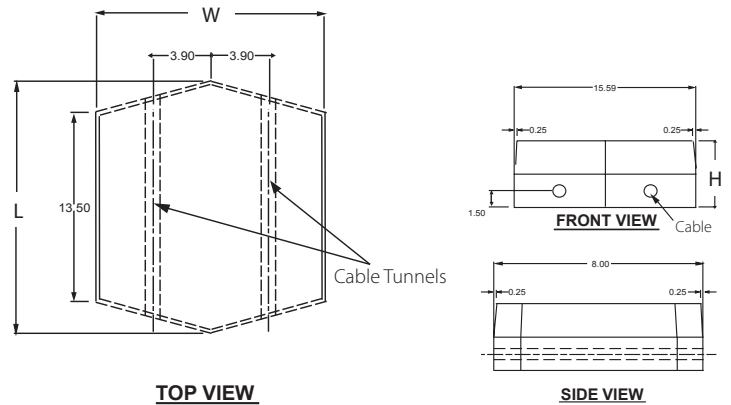

Armortec Minimum Physical Requirements per ASTM 06684-04

MIN. DENSITY (IN AIR) LBS/FT ³		MIN. COMPRESSIVE STRENGTH PSI		MAX WATER ABSORPTION LBS/FT ³	
Ave. of 3 Units	Individual Unit	Ave. of 3 Units	Individual Unit	Ave. of 3 Units	Individual Unit
130	125	4,000	3,500	9.1	11.7

Manufactured by Geostar Corporation

Filter Point
Filter Band™
Uniform Section
Enviromat™
Articulating Block
Hydrocast™ Armor Units

HYDROTEx™

Fabric-formed Concrete Erosion Control and Armoring Systems



CONSTRUCTION &
QUALITY CONTROL
MANUAL

Hydrotex, Hydrocast, Filter Band, and Enviromat are trademarks of Geostar Corporation.
© 2001, Geostar Corporation. Printed in U.S.A.

The information contained herein was derived based on the use of products manufactured by Geostar Corporation. Their use or application with the products of another manufacturer is not recommended, due to differences in material composition or differences in manufacturing technique, and may produce unintended results. This information is intended for the use of the entity or individual to whom it is addressed and may contain information that is privileged, confidential and exempt for disclosure under applicable law.

The information contained herein is furnished without charge or obligation, and the recipient assumes all responsibility for its use. Because conditions of use and handling may vary and are beyond our control, we make no representation about, and are not responsible for, the accuracy or reliability of said information or the performance of any product. Any specifications, properties or applications listed are provided as information only and in no way modify, enlarge or create any warranty. Nothing contained herein is to be construed as permission or as a recommendation to infringe any patent.

Contents

Introduction & General Information for all Installations	
Introduction	2
Characteristics of Fabric Forms	3
Fine Aggregate Concrete Properties and Requirements	4
Site Preparation	6
Filter Fabric	6
HYDROTEX™ Linings and Mats	
Types of Concrete Linings and Mats	8
Typical Dimensions & Property Requirements	10
HYDROTEX Fabric Form Panels	12
Ordering	
Shop and Layout Drawings	
Proper Storage and Handling	
Contraction	
Factory Sewn Seams	
Baffles	
Irregular Panels	
Weep Tubes	
High Strength Cabling (for Articulating Block Mat)	
Requirements for Installing and Anchoring	18
Installation of HYDROTEX Linings and Mats	20
Equipment and Tools	
Sequence of Installation	
Sequence of Fine Aggregate Pumping	
Special Considerations	
HYDROCAST™ Armor Units	
General Information	32
Ordering Fabric Forms	
Unfilled Width/Length to filled Thickness & Width/Length	
Filled Form Volume	
Proper Storage and Handling	
Contraction	
Installation	37
Equipment and Tools	
Sequence of Installation	
Sequence of Fine Aggregate Pumping	
Special Considerations	
Appendices	43

Geostar Corporation
53 Perimeter Center East, Suite 250
Atlanta, Georgia 30346 (USA)
Tel: 1.800.253.0561 or 770.399.5051
Fax: 770.394.5999
<http://www.geostarcorporation.com>
e-mail: info@geostarcorporation.com

Introduction & General Information

Introduction

HYDROTEX™ brand fabric forms, manufactured by Geostar Corporation, are used to construct a wide range of concrete-filled systems that provide outstanding performance in erosion control, scour protection and repair, foundation, environmental and marine construction applications. The fabric forms are constructed of woven, double-layer, synthetic fabric. HYDROTEX linings and mats and HYDROCAST™ Armor Units are installed by positioning fabric forms over the areas to be protected and then pumping high-strength, fine aggregate concrete (structural grout) into the forms. The fabric forms can be placed and filled either underwater or in-the-dry. The high-strength, fine aggregate concrete is used in place of conventional concrete because of its pumpability, high-strength, impermeability, and absorption resistance.

HYDROTEX linings and mats and HYDROCAST Armor Units are used to protect canals, channels, culverts, dams, dikes, embankments, bridge piers, spillways, underwater pipelines, and other hydraulic and marine structures from the forces of flowing water and wave action. HYDROTEX Linings and Mats are also used to protect geomembranes and geosynthetic-clay liners from mechanical damage in landfills, reservoirs, sewage lagoons, ash pits, cooling ponds, and other containment, capping and environmental applications.

In addition to significant performance advantages, HYDROTEX fabric-formed concrete is economical to install. It eliminates the need for heavy equipment, steel reinforcement, and forming and stripping of conventional concrete forms. It generally does not require specialized labor or dewatering of the job site prior to installation.

This manual is designed as a guideline for the construction and quality control for HYDROTEX fabric-formed concrete systems. Prior to the delivery of materials to the job site, its contents should be thoroughly reviewed by those given the responsibility for design, installation and inspection.

The contents of this manual are only general guidelines and do not relieve the contractor of the responsibility to adhere to the Contract Drawings and Specifications. It is recommended that the Engineer of Record review these guidelines and specify any additional, project-specific installation procedures he considers necessary.

General Characteristics of Fabric Forms for HYDROTEX Linings and Mats and HYDROCAST Armor Units

HYDROTEX fabric forms are constructed of high-strength, synthetic yarns formed into woven, double-layer fabrics. Textured yarns comprise a minimum of 50% of the fabric weight for improved adhesion to fine aggregate concrete and better filtration characteristics. The yarns are woven into a network such that the yarns retain their dimensional stability relative to each other, including at the fabric selvages (edges). The selvage edges of the top and bottom layers of fabric are reinforced for a width of 1.35 inches (35 mm) by adding at least 6 warp yarns to the selvage construction. The reinforced selvage edges provide superior strength to sewn seams used in the fabrication of fabric forms.

The fabric forms are designed to serve as filters as well as concrete forms with a permeability selected to permit expulsion of excess concrete mixing water while retaining the cement solids. The fabric forms are resistant to alkalis, acids, organic solvents, and biological organisms.

After the fabric forms are woven and inspected, mill width rolls of fabric are factory assembled either into panels designed to fit project dimensions and topography or into forms of specified dimensions.

The designs of the fabric forms and their woven construction provide HYDROTEX fabric forms with a range of important benefits including:

High Strength, enabling the fabric forms to perform effectively under concrete pumping pressure;

High Elongation, to resist tear and puncture failure and to reduce form contraction;

Excellent permeability, to expel excess mixing water;

Lightweight, for ease of installation; and

Uniformity in dimensions, to assure consistent performance characteristics.

The fabric forms are designed to adhere to the fine aggregate concrete fill. Though it is assumed that the top layer of the fabric form may eventually be lost to abrasion and ultraviolet degradation, the bottom layer is expected to last indefinitely and to provide a low modulus tensile reinforcement.

There are two primary types of HYDROTEX fabric-formed concrete systems - HYDROTEX Linings and Mats and HYDROCAST Armor Units.

Fine Aggregate Concrete

Fine aggregate concrete consists of a mixture of Portland cement, fine aggregate (sand) and water, so proportioned and mixed as to provide a pumpable fine aggregate concrete.

Fine aggregate concrete has a typical mix water/cement ratio of 0.65 to 0.75. The pumping of fine aggregate concrete into the fabric forms causes a reduction in the water content by filtering excess mixing water through the permeable fabric. The reduction of mixing water substantially improves the water/cement ratio of the in-place fine aggregate concrete thereby increasing its strength and durability.

With a typical loss of approximately 15% of the total mixing water, 27 ft³ (or 1.0 m³) of pumpable fine aggregate concrete will reduce to approximately 25 ft³ (0.93 m³) of hardened concrete. The mixing water reduction will also result in an increase of approximately 8% in the sand and cement per cubic yard (m³) of concrete. The range of fine aggregate concrete mix proportions provided in Table 1.0 has been developed under a variety of field conditions.

Air Entrainment

Mixes designed with 5% to 8% air content will improve the pumpability of the fine aggregate concrete and the freeze-thaw resistance of the hardened concrete.

Admixtures

Pozzolan grade fly ash may be substituted for up to 35% of the cement as an aid to pumpability. (The pumpability of fine aggregate concrete mixes containing coarse sand is improved by the addition of fly ash.)

Grout fluidifier, water reducing or set time controlling agents may be used as recommended by their manufacturers to improve the pumpability and set time of the fine aggregate concrete.

Ready-mix

Fine aggregate concrete should be pre-mixed at a concrete batch plant and delivered by ready-mix trucks to the job site. *If a continuous supply of concrete can not be assured a reserve of concrete should be maintained in a holding hopper equipped with an agitator.*

The consistency of the fine aggregate concrete delivered to the job site should be maintained in the 9-11 second range when passed through the 0.75 inch (19 mm) orifice of the standard flow cone that is described in ASTM D 6449 (Fig. 1). *Tests utilizing a concrete slump cone are not appropriate.*

Components:

Portland cement should conform to ASTM C 150, Type I or II.

Fine aggregate should conform to ASTM C 33, except as to grading. Aggregate grading should be reasonably consistent and should not exceed the maximum size which can be conveniently handled with available pumping equipment.

Water for mixing should be clean and free from injurious amounts of oil, alkali, organic matter or other deleterious substances.

Pozzolan, if used, should conform to ASTM C 618, Class C, F or N.

Plasticizing and air entraining admixtures, if used, should conform to ASTM C 494 and ASTM C 260, respectively.

Table 1.0 Typical Range of Mix Proportions		
Material	Mix Proportions lb/yd ³ (kg/m ³)	After Placement Mix Proportions lb/yd ³ (kg/m ³)
Cement	750-850 (445-505)	805-915 (475-540)
Sand	2120-2030 (1255-1205)	2290-2190 (1355-1295)
Water	540-555 (320-325)	460-470 (270-275)
Air	As Required	As Required



Figure 1

Compression Testing of Fine Aggregate Concrete:

The fine aggregate concrete mix should exhibit the physical requirements of Table 2.0 at 28 days, when made and tested in accordance with ASTM C 31 and 39.

Some specifications require that the contractor prepare test cylinders cast in fabric tubes (test socks) as well as concrete cylinders cast in conventional impermeable molds.

The average compression strength of the concrete cylinders cast in fabric tubes should be at least 10% higher in 7 days than that of companion concrete cylinders made in accordance with ASTM C 31, and not less than 2,500 psi at 28 days.

Preparation of Fabric Tubes:

Fabric formed cylinders are prepared by attaching a 5.5 inch (140 mm) diameter (to allow for fabric stretching of approximately 5 to 10 percent) by 30 inch (762 mm) long fabric tube to a regulator cap (Fig. 27) and filling it with fine aggregate concrete, holding an injection pressure of approximately 10 psi (69 kPa) on the fluid concrete for a period of 10 minutes. A 12 inch (304 mm) long section is cut from the middle of the hardened specimen and capped and tested in the normal manner, with customary correction being applied for the slightly non-standard diameter.

Regulator Caps and fabric tubes are available from Geostar Corporation.

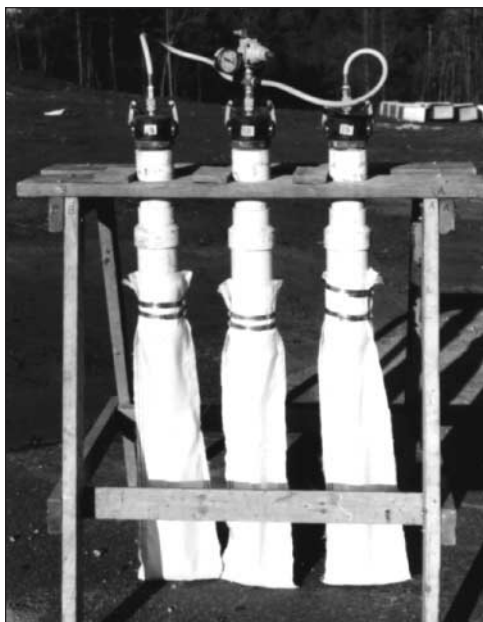

Figure 2

Pumpability

The fine aggregate concrete mix which is used to fill fabric forms is very fluid compared to a conventional mix (see Table 2.0). A conventional concrete mix has a 4 to 6 inch (100 to 150 mm) slump. However, as the fabric form is filled the excess mixing water in the pumped mix is rapidly expelled through the water-permeable fabric form, resulting in the pumped mix ratio of approximately 0.7 being reduced to a more typical ratio of 0.5. Within thirty minutes after placement, the consistency of the fine aggregate concrete within the fabric forms is that of a very low slump concrete.

Strength and Durability

Fabric formed fine aggregate concrete possesses superior physical properties. The compressive strength of fine aggregate concrete pumped into fabric forms is typically 1.5 to 1.75 times greater than companion samples taken from conventional concrete test cylinders. In addition, the fine aggregate concrete has less than 5% water absorption. This combined with a “case hardening” effect produces a concrete that is abrasion resistant, durable under freeze thaw action, resistant to “break up” caused by thermal cracking, highly impermeable, and resistant to acid, alkali, salt, organic solvents, biological organisms and petrochemicals. It is equivalent to a rich conventional concrete mix placed at an extremely low water/cement ratio. The “case hardening” effect is a result of a higher percentage of the cement in the cement-rich, fine aggregate concrete mix being drawn to the surface of the fabric forms by the expelled excess mixing water.

The higher compressive strength and “case hardening” achieved by the fine aggregate concrete permits concrete linings, mats and armor units to be constructed without reinforcement steel.

Environmental Compatibility

When fine aggregate concrete is pumped into the fabric forms an average of 0.25% of the cement content (with a maximum of 0.5%) is lost through the fabric forms, or the equivalent of approximately 2000 g of cement to a cubic yard (2,600 g/m³) of concrete pumped. The addition of 40 g of cement to a cubic yard (50 g/m³) of water will raise the pH value of water approximately 1.0. This should fall well within the nominal pH range (7.0 to 9.5) of potable water.

The following procedures, should assure that the rise in pH during fine aggregate concrete pumping of fabric formed linings, mats or armor units will not exceed 1.0:

- In stagnant water, the total volume of water must be at least 50 times the volume of fine aggregate concrete pumped.
- In flowing water, the rate of water flow in cubic yards per minute (m³/min) must exceed the rate of fine aggregate concrete pumped in cubic yards per hour (m³/hr).

Table 2.0 Physical Requirements			
Minimum Required Compressive Strength of Concrete psi (MPa)		Maximum Water Absorption Requirements lb/ft ³ (kg/m ³) Weight Classification - Oven-Dry Weight of Concrete, lb/ft ³ (kg/m ³)	
Average of Three Tests	Individual Test	105 (1682) to less than 125 (2002)	125 (2002) or more
2,000 (27.6)	1,400 (24.1)	10 (203)	8 (160)

Site Preparation

Standard excavating, grading and compaction equipment should be used to grade and compact the area to be protected and to excavate anchor, flank and toe trenches and aprons. *Specific information on the excavation of trenches is located on page 16 of this manual.*

The areas where the fabric forms are to be placed should be constructed to the lines and grades shown on the Contract Drawings. Where such areas are below the allowable grades, they should be brought to grade by placing compacted layers of select material. Vegetation and obstructions, such as roots and projecting stones, should be removed. Unsuitable soils should be removed and replaced with select material and compacted according to Contract Specifications. *Failure to do so may cause the fabric formed concrete linings, mats or armor units to bridge thus leaving a void beneath the structure.*

Draglines or bulldozers should generally be used for excavation and rough grading of the areas; however, they are not suitable for fine grading. Fine grading should be done with a hydraulic backhoe, grader or similar equipment. In most cases the contractor should be prepared to dress the areas with hand tools prior to placing the fabric forms. If an underwater dredge is used, the dredge operator must avoid overcutting or the cutting of stepped or scalloped slopes, particularly in cohesive soils.

Whenever the concrete linings, mats or armor units extend partially or entirely underwater, it will be necessary to perform underwater inspection and to dress the areas with hand tools prior to placement of the fabric forms. Stepped or scalloped slopes should be leveled first by dragging a steel beam or channel over the slope. *Underwater installation may be facilitated if a leveling course of granular material is placed and dressed prior to placement of the fabric forms.*

Filter Fabric (Geotextiles)

Geotextile filter fabric is often used under fabric-formed concrete linings and mats and concrete armor units (Fig. 3). The filter fabric is a permeable sheet of woven or nonwoven fabric selected in accordance to the gradation and permeability of the subsoils. The filter fabric must have opening sizes small enough to prevent soil from passing through and be permeable enough to allow the required flow of water. The filter fabric should conform to the minimum physical requirements shown in Table 3.0. Filter fabric should be protected from exposure to direct sunlight.

Filter Fabric Installation

If called for in the Contract Drawings and Specifications, filter fabric should be placed over the graded and compacted areas. The filter fabric should be placed loosely but without wrinkles or folds. Filter fabric sheets should be held in position by ballasting with sandbags or using "U"-shaped staples. Filter fabric placement should proceed concrete lining, mat or armor unit placement by no more than 2,000 ft² (200 m²).

As placement of the fabric formed concrete linings, mats or armor units proceeds, the filter fabric should be secured at toes of slopes and buried at crowns of slopes and flank

Slope Stability:

Fabric-formed linings, mats and armor units provide concrete protection for earthen structures subject to flowing water, waves and wind.

*Though fabric-formed concrete can be installed on slopes steeper than those suitable for quarry stone or precast concrete blocks or for compacted soil or soil cement construction, **fabric-formed concrete linings and mats are not designed to improve slope stability.** Their inherent weights are selected for the purposes of hydraulic stability and are not to be considered sufficient to impart stability to slopes subject to rotational, global or sliding failure or where severe consolidation of the subgrade is anticipated.*

Fabric-formed armor units, however, may be designed as heavy weight units, and can be used to construct structures that act as gravity retention structures for steep slopes subject to failure.

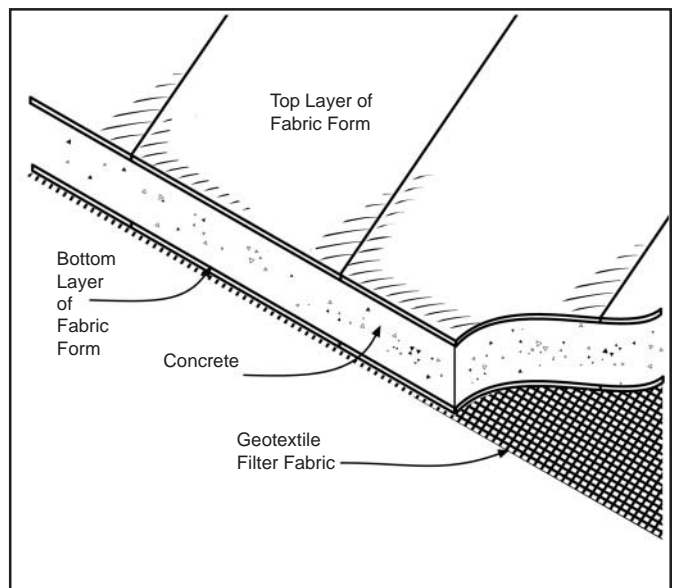

Figure 3

Foot traffic:

Foot traffic on the prepared areas should be at a minimum. Should traffic be unavoidable, the contractor should place board walks along the finished graded areas. This will reduce the amount of hand dressing required to remove footprints. Heavily trafficked areas will reflect through the installed fabric-formed concrete linings or mats as irregularities in the surface.

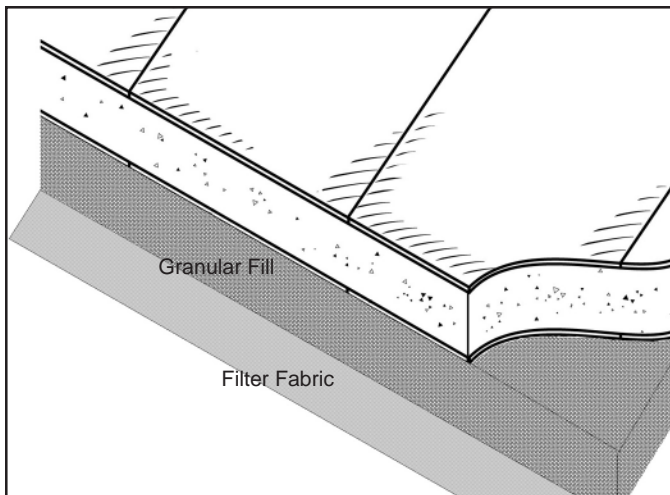

Figure 4

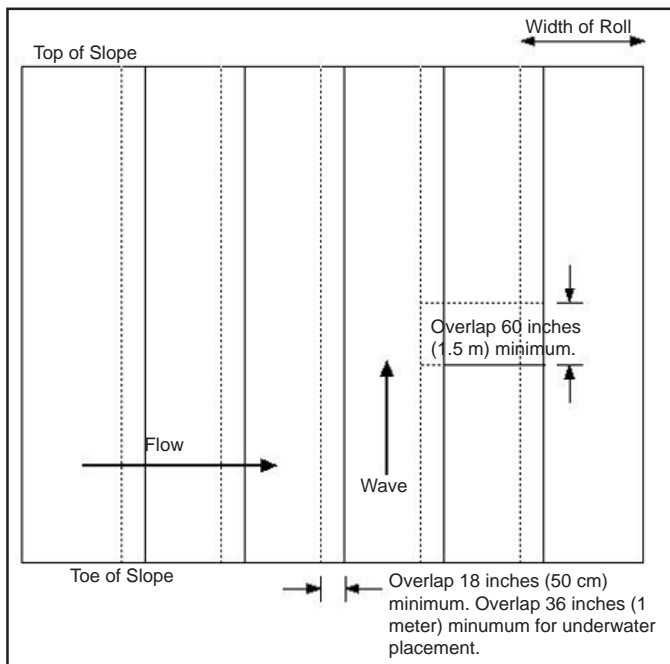

Figure 5

Manufacturer's Certification: Prior to accepting delivery from the supplier, verify that the filter fabric satisfies all provisions of the Contract Specifications and that mill certificates have been provided.

Table 3.0 - Filter Fabric ^{1,2} Property Requirements			
Property	Test Method	Units	Values
Grab Tensile Strength	ASTM D 4632	lbf (N)	90 (400)
Elongation at Break	ASTM D 4632	%	15
Trapezoidal Tear Strength	ASTM D 4533	lbf (N)	30 (130)
Permittivity	ASTM D 4491	sec ⁻¹	0.5

Notes:

1. Conformance of filter fabrics to specification property requirements shall be based on ASTM D 4759, "Practice for Determining the Specification Conformance of Geotextiles."
2. All numerical values represent minimum average roll values (i.e., average of test results from any sample roll in a lot shall meet or exceed the minimum values). Lots shall be sampled according to ASTM D 4354, "Practice for Sampling of Geosynthetics for Testing."

trenches. Care must be taken when placing filter fabric to assure that the placement method does not damage the fabric.

When installing fabric form linings, mats and armor units on silts, sandy silts or fine sand, the specifications may call for the addition of a sublayer. The sublayer serves to prevent serious downslope migration of the subsoil particles. Sublayers should be constructed of granular material.

Granular sublayers, as shown in Figure 4, are placed between the filter fabric and the fabric form. They generally have a thickness of between 3 and 9 inches (8-20 mm).

Filter Fabric Joints

Lapped Joints

Lapped joints are easy to install but require additional filter fabric. The sheets of filter fabric should be placed as shown in Figure 5, with the principal direction (roll length or warp direction) running down the slope. Overlapping of fabric sheets should adhere to the Contract Drawings and Specifications but be at least 18 inches (50 mm) but more generally 36 inches (1 meter), especially when laying underwater. Generally, sheets are overlapped parallel to the slope, as shown in Figure 5, to retain any soil particles migrating along the bank. If soil migration is unlikely or the fabric is being set in flowing water or current the overlap should be reversed.

Seamed Joints

Sewn seams are the most reliable method of joining filter fabric sheets and require the least amount of fabric. Seams are made on-site using portable, handheld, sewing machines and nylon or polyester sewing thread. Generally, a prayer (flat) seam with a U.S. Federal Standard Type 101 (Fig. 6) stitch is the most suitable.

Combining Lapped and Seamed Joints
Most filter fabric suppliers will factory-sew filter fabric rolls together to form multiple roll width sheets. The contractor may lap the joints of these large sheets thus taking advantage of the ease of lapped joints and the reliability of sewn seams.

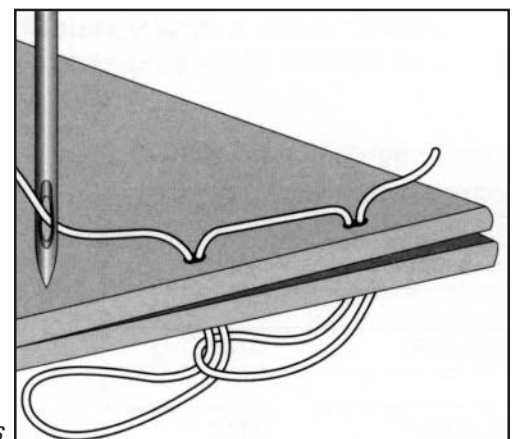

Figure 6

HYDROTEX Linings and Mats

Types of Linings and Mats

HYDROTEX linings and mats are available in five basic styles: Filter Point (FP), Filter Band™ (FB), Uniform Section (US), Enviromat™ (EL & EB), and Articulating Block (AB). Additionally, special fabric forms may be woven to suit the specific requirements of a project. Each is designed with the required strength, stability and permeability properties required to assure the pumping in-place of a durable and abrasion resistant concrete lining or mat system with specific thickness, weight and hydraulic characteristics. Forms of different styles and thickness can be incorporated in the same installation. Table 4.0 provides typical dimensions, weights and volumes for the range of standard HYDROTEX linings and mats. Table 5.0 provides property requirements for the fabric used in form construction.

Filter Point (FP) Linings

Filter Point Linings (Fig. 7) with filtering points (drains) provide erosion resistant, permeable concrete linings for ditches, channels, canals, streams, rivers, ponds, lakes, reservoirs, marinas, and protected port and harbor areas. Filter Point Linings have a cobbled surface and a relatively high coefficient of hydraulic friction in order to achieve lower flow velocities and to reduce wave run-up. The filter points provide for the relief of hydrostatic uplift pressures, increasing the system's stability.

Filter Point Linings were the first type of fabric form for concrete developed. In 1965, a Dutch patent was issued for "fabric-formed slope paving." The form suggested by this patent was later refined to create the first "filter point" lining.

Filter Band™ (FB) Linings

Filter Band Linings (Fig. 8) are similar to Filter Point, providing an effective and highly permeable concrete lining that resists erosive forces. Filter Band differs from Filter Point in that the form creates interconnected, tubular concrete elements that are separated by large, interwoven filter bands. The filter bands provide for greater reduction of uplift pressures than Filter Point Linings. Also, the biaxial alignment of the tubular elements creates two directionally-determined coefficients of hydraulic friction. As a result, Filter Band achieves greater reduction of flow velocity or wave energy than Filter Point.

Filter Band concrete linings are specified in situations similar to those for which Filter Point might be specified, but which also require greater relief of uplift pressures, higher reduction of flow velocities, or greater reduction of wave run up.

Filter Points and Filter Bands:

Filter points and filter bands define the locations at which the two layers of fabric form are interwoven to form water permeable drains. The interweaving of the two layers results in an area of double density, higher strength, single layer fabric. The weave of the fabric at the center of these drain locations incorporates a "Twill Weave" in order to "open up the fabric" and permit the flow of ground water through the drain while retaining soil particles. A twill is a weave characterized by diagonally-oriented yarns woven over then under more than one yarn. Figure 9 illustrates the construction of a filter point with a twill weave center designed to function as a drain as well as a filter. The cross shaped design reduces applied stress to the filter point during concrete pumping. Filter bands are also constructed with a twill weave center.

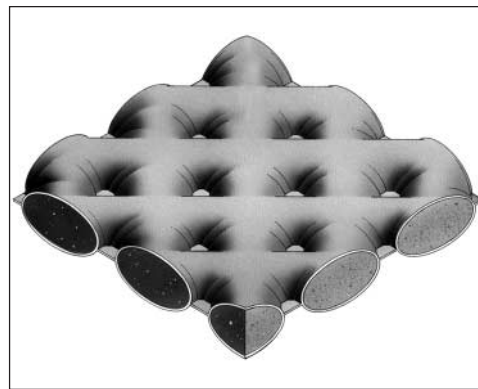

Figure 7



Figure 8

Manufacturer's Certification:

The manufacturer of the fabric forms should submit a manufacturer's certificate stating that the supplied fabric forms meet the criteria of the manufacturer's specifications, as measured in full accordance with the test methods and standards referenced. The certificates should include the following information about each fabric form shipment:

- *Manufacturer's name and current address*
- *Full product name*
- *Style and product code number*
- *Form number(s)*
- *Polymer types*
- *Manufacturer's certification statement*

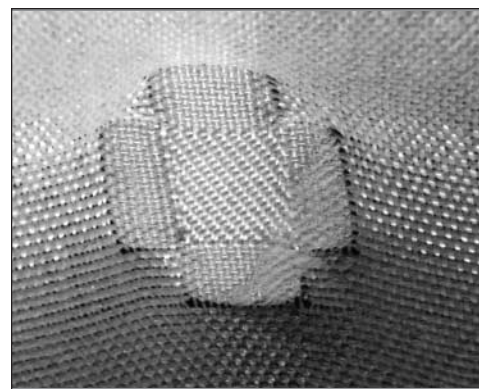

Figure 9

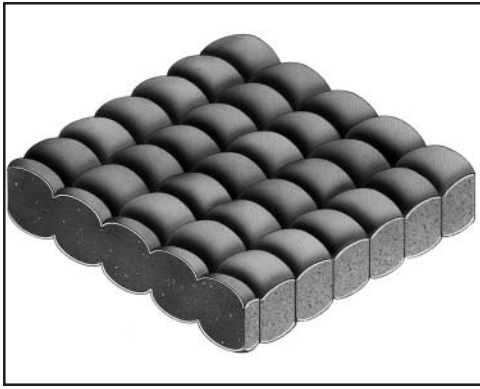

Figure 10

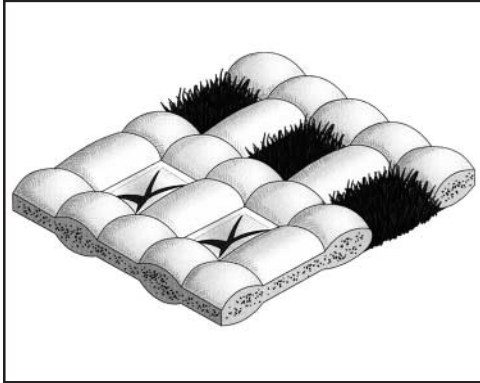

Figure 11

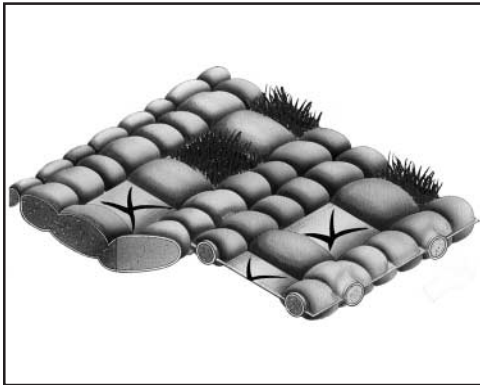

Figure 12

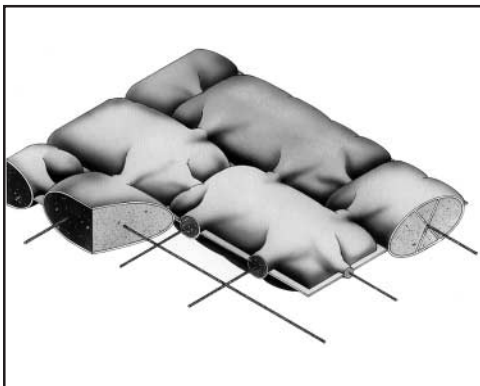

Figure 13

Uniform Section (US) Linings

Uniform Section Linings (Fig. 10) are similar to traditional concrete slope paving. They create a solid, high quality concrete lining with a relatively low hydraulic resistance and uniform cross section. These linings are used to reduce the infiltration or exfiltration of aggressive waste and chemical fluids into or out of open channels and basins. They are also used to reduce exfiltration in arid regions where open channels and basins require watertight linings.

Uniform Section Linings are resistant to leachate and most chemicals. They protect geosynthetic liners from mechanical damage, exposure to UV light, and freeze-thaw cycles. These self-supporting, high strength linings permit construction on steep side slopes and replace the conventional use of clay or sand as liner protection. Placement of the forms and concrete filling can be performed without the use of equipment on the liner. The tensile strength and abrasion resistance of the fabric protect the liner from the pumped concrete.

Enviromat™ (EL and EB) Linings

Enviromat Linings EL (Fig. 11) and EB (Fig. 12) are installed to provide protection against periodic high flows. After installation, vegetation can be planted within the open structure of the lining to create a more natural appearance. Enviromat Linings are used in drainage ditches and on the upper slopes of channels, canals, lakes, reservoirs, rivers, and other water courses as well as for embankments subject to heavy run-off.

Enviromat Linings are comprised of concrete-filled elements and unfilled areas that allow for the establishment of vegetation. Once the concrete sets, the defined unfilled and interwoven areas are opened by cutting the fabric and are planted or are filled with topsoil and seeded. Within a growing season a vegetated cover will normally extend over the lining, resulting in an erosion control system with the hydraulic, ecological and aesthetic features desired. EL linings have a greater open area (~35%) than EB (~20%), so a vegetated cover will be established more rapidly. However, EB linings are designed to articulate and are more tolerant of uneven settlement after installation.

Articulating Block (AB) Mats

Articulating Block Mats (Fig. 13) form cable-reinforced concrete block mattresses that resist erosive forces. They are often constructed where a revetment is exposed to frontal attack by wave action. AB Mats are typically used to protect coastlines, canals, rivers, lakes, reservoirs, underwater pipelines, bridge piers, and other marine structures from propeller wash, ship wakes, wind waves, currents, and high velocity flows. They are also used in environmental construction for landfill caps, down chutes, and collector channels.

The AB fabric form consists of a series of compartments linked by an interwoven perimeter. Grout ducts interconnect the compartments, and high strength revetment cables are installed between and through the compartments and grout ducts. Once filled, the AB Mats become a mattress of pillow-shaped, rectangular concrete blocks. The interwoven perimeters between the blocks serve as hinges to permit articulation. The cables remain embedded in the concrete blocks to link the blocks together and facilitate articulation.

Table 4.0 - Linings and Mats, Typical Dimensions, Weight and Volume

Filter Point	FP220	FP400	FP600	FP800	FP1000	FP1200
Average Thickness, inches (mm)	2.2 (56)	4.0 (102)	6.0 (152)	8.0 (203)	10.0 (254)	12.0 (305)
Mass Per Unit Area, lb/ft ² (kg/m ²)	25 (121)	45 (220)	68 (330)	90 (440)	113 (550)	135 (661)
Filter Point Spacing, inches (mm)	5.0 (127)	8.0 (203)	10.0 (254)	12.0 (305)	14.0 (356)	16.0 (406)
Area per Filter Point, in ² (cm ²)	2.0 (12.9)	2.0 (12.9)	6.3 (40.7)	6.3 (40.7)	12.2 (78.7)	12.2 (78.7)
Perimeter per Filter Point, inches (mm)	6.5 (165)	6.5 (165)	11 (279)	11 (279)	15 (381)	15 (381)
Concrete Coverage, ft ² /yd ³ (m ² /m ³)	136 (16.6)	75 (9.1)	50 (6.1)	38 (4.6)	30 (3.6)	25 (3.0)
Shear Resistance, lb/ft ² (kg/m ²)	11 (54)	20 (98)	30 (146)	40 (195)	50 (244)	60 (293)

Filter Band™	FB400	FB800	FB1200
Average Thickness, inches (mm)	4.0 (102)	8.0 (203)	12.0 (305)
Mass Per Unit Area, lb/ft ² (kg/m ²)	45 (220)	90 (440)	135 (661)
Filter Band Spacing, inches (mm)	8.0 (203)	16.0 (406)	24.0 (609)
Concrete Coverage, ft ² /yd ³ (m ² /m ³)	75 (9.1)	38 (4.6)	25 (3.0)
Shear Resistance, lb/ft ² (kg/m ²)	15 (73)	29 (142)	44 (215)

Uniform Section	US300	US400	US600	US800	US1000
Average Thickness, in (mm)	3.0 (76)	4.0 (102)	6.0 (152)	8.0 (203)	10.0 (254)
Mass Per Unit Area, lb/ft ² (kg/m ²)	34 (165)	45 (220)	68 (330)	90 (440)	113 (550)
Drop Point Spacing, in (mm)	3 x 3 (76 x 76)	3 x 4 (76 x 102)	3 x 6 (76 x 152)	4.5 x 7.5 (114 x 191)	4.5 x 9 (114 x 229)
Concrete Coverage, ft ² /yd ³ (m ² /m ³)	100 (12.1)	75 (9.1)	50 (6.1)	38 (4.6)	30 (3.6)
Shear Resistance, lb/ft ² (kg/m ²)	14 (68)	18 (88)	28 (137)	37 (181)	46 (224)

Enviromat	EL250	EL400
Average Thickness, inches (mm)	2.5 (64)	4 (102)
Mass Per Unit Area, lb/ft ² (kg/m ²)	28 (138)	45 (220)
Open (vegetated) Area, %	35	35
Concrete Coverage, ft ² /yd ³ (m ² /m ³)	120 (14.6)	75 (9.1)
Shear Resistance, lb/ft ² (kg/m ²)	10 (49)	16 (78)

Enviromat	EB300	EB500
Average Thickness, inches (mm)	3.0 (76)	5.0 (127)
Mass Per Unit Area, lb/ft ² (kg/m ²)	34 (165)	56 (275)
Open (vegetated) Area, %	20	20
Concrete Coverage, ft ² /yd ³ (m ² /m ³)	100 (12.1)	60 (7.3)
Shear Resistance, lb/ft ² (kg/m ²)	12 (59)	20 (98)

Articulating Block	AB400	AB600	AB800	AB1000	AB1200
Average Thickness, in (mm)	4.0 (102)	6.0 (152)	8.0 (203)	10 (254)	12 (305)
Mass Per Unit Area, lb/ft ² (kg/m ²)	45 (220)	68 (330)	90 (440)	113 (550)	135 (661)
Mass per Block, lb (kg)	88 (39.8)	188 (85.2)	325 (148)	563 (255)	844 (382)
Nominal Block Dimensions, in (mm)	20 x 14 (508 x 356)	20 x 20 (508 x 508)	20 x 26 (508 x 660)	30 x 24 (762 x 610)	30 x 30 (762 x 762)
Concrete Coverage, ft ² /yd ³ (m ² /m ³)	75 (9.1)	50 (6.1)	38 (4.6)	30 (3.6)	25 (3.0)
Shear Resistance, lb/ft ² (kg/m ²)	26 (127)	39 (190)	52 (254)	65 (317)	78 (381)

Note: Values shown are typical and will vary with weight of concrete and field conditions.

Physical Requirements: At the time of delivery to the job site, the fabric used in form construction should conform to the minimum property requirements of Table 5.0. All fabric forms should be free of rips or defects that would interfere with the proper placing of the fabric forms or significantly impair the strength or performance of the construction. Minor holes incidental to the usual method of manufacture or minor rips resulting from shipment and delivery or handling are not grounds for rejection. Small rips or holes are repaired by the contractor in the field by sewing.

Table 5.0 - Property Requirements - Form Fabric^{1, 2}

Property	Test Method	Units	Values
Physical:			
Composition of Yarns			Nylon or polyester
Mass Per Unit Area (double-layer)	ASTM D 5261	oz/yd ² (g/m ²)	12 (403)
Thickness	ASTM D 5199	mils (mm)	25 (0.6)
Mill Width		in (m)	76 (1.92)
Mechanical:			
Wide-Width Strip Tensile Strength	- Machine	ASTM D 4595	lbf/in (kN/m)
	- Cross		lbf/in (kN/m)
Elongation at Break	- Machine	ASTM D 4595	%
	- Cross		%
Trapezoidal Tear Strength	- Machine	ASTM D 4533	lbf (N)
	- Cross		lbf (N)
Hydraulic:			
Apparent Opening Size (AOS)	ASTM D 4751	U.S. Standard Sieve (mm)	40 (0.425)
Flow Rate	ASTM D 4491	gal/min/ft ² (l/min/m ²)	90 (3665)
Flow Rate through Filter Point or Band (if applicable)	ASTM D 4491	gal/min/ft ² (l/min/m ²)	7 (285)

Notes:

1. Conformance of fabric to specification property requirements shall be based on ASTM D 4759, "Practice for Determining the Specification Conformance of Geotextiles."
2. All numerical values represent minimum average roll values (i.e., average of test results from any sample roll in a lot shall meet or exceed the minimum values). Lots shall be sampled according to ASTM D 4354, "Practice for Sampling of Geosynthetics for Testing."
3. Yarns used in fabric construction shall not contain partially oriented (POY), draw-textured, and/or staple yarns.

Fabric Form Panels

Fabric form mill rolls are factory assembled by sewing several mill widths of fabric forms side-to-side to form large panels. Mill width rolls of fabric forms are cut to the lengths required and their two layers of fabric separately sewn together, bottom layer to bottom layer and top layer to top layer, to form multiple mill width panels (Fig. 14). Site conditions and manpower and equipment resources at the job site will determine the maximum sizes of individual panels.

Ordering Fabric Form Panels

The ordering of fabric form panels should be done in advance of the start of the project, to allow time for the preparation, submittal and approval of layout and shop drawings. Project plans and specifications should be submitted to Geostar's technical support department. Trained technicians translate the site plans, grades, elevations, contours and construction details into CAD systems where they develop cost-effective take-offs and fabric-formed concrete shop and layout drawings, tailored to the project's design requirements. This design technique and CAD layout verification procedure will assure accurate dimensioning and material quantity takeoffs.

Shop and Layout Drawings

Fabric form panel shop drawings are plotted to scale and each panel is numbered. Figure 15 is a typical panel shop drawing. Baffle locations and the edges of the panel which are to be sewn or closed and which are unsewn or left open, for joining to adjacent panels, are clearly marked on each panel shop drawing. The fabric forms are dimensioned to include all aprons, overlaps, and anchor, flank or toe trenches and contraction factors. The forms are over-dimensioned, in both length and width, to make allowance for form contraction as they are filled with fine aggregate concrete. (Contraction factors are discussed on the following page.)

Layout drawings (Fig. 16) showing the field assembly of the fabric form panels for the entire project are prepared. The drawings identify each panel number, its location and sequence of installation, pertinent elevations and coordinates, direction of flow, anticipated water levels, and structures such as roads, curbs, bridges, intake and discharge pipes, culverts, ramps and other existing and future structures that may effect the placement of the fabric formed concrete linings, mats or armor units. In addition, lap joint locations are shown as well as notes regarding special field splicing operations, if required.

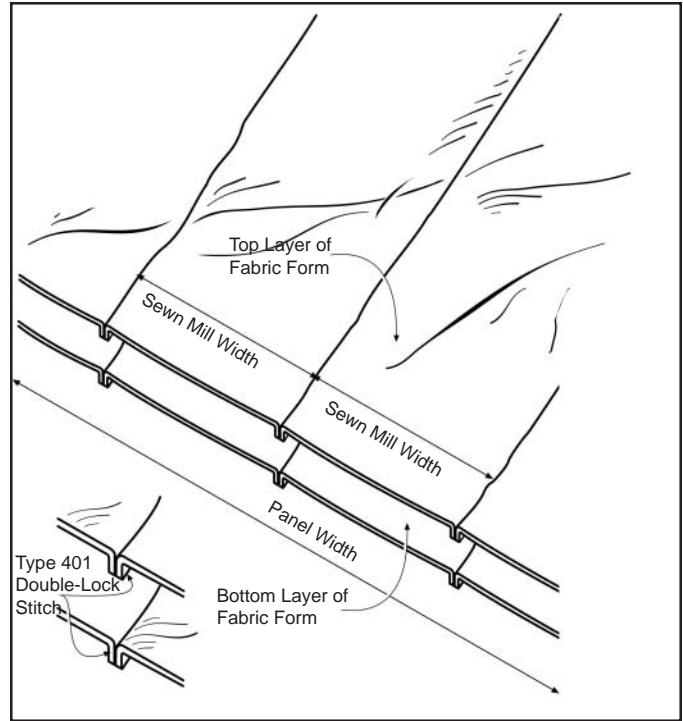

Figure 14

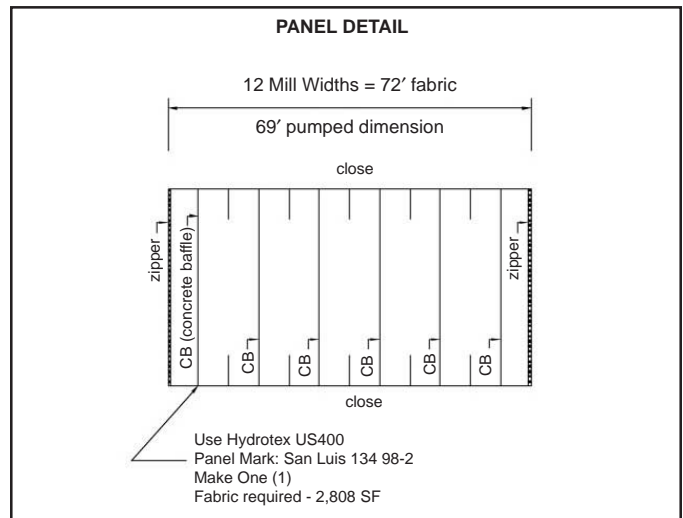

Figure 15

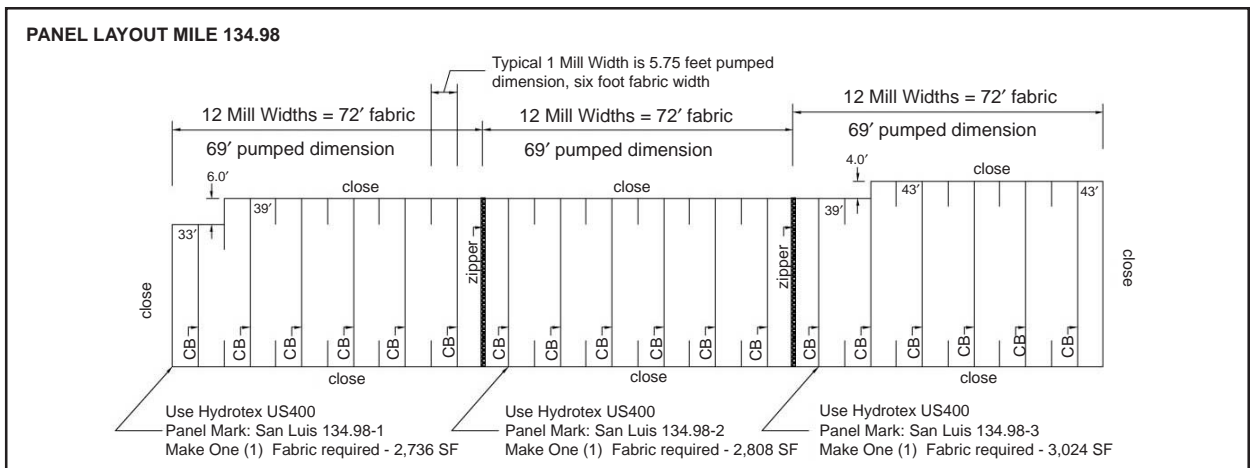

Figure 16



Figure 17

Minor changes in dimensions, grades, contours and field conditions from those shown on the contract drawings may be accommodated by fabric stretch or adjustment during field placement.

A submittal package which includes shop and layout drawings, a list of numbered fabric form panels, panel dimensions and areas, and a manufacturer's certification is assembled and forwarded to the contractor for submittal to the project engineer.

Upon the project engineer's approval of the submittal package, Geostar's manufacturing department commences panel fabrication and confirms the delivery schedule.

Proper Storage and Handling of Fabric Forms

Fabric forms are delivered at the job site in trailers or ocean containers. Fabric forms are stacked in a manner that assures ease of unloading. Standard 40 ft (12 m) long trailers or containers hold up to 215,000 ft² (20,000 m²) of fabric forms per load. Fabric forms are normally delivered to the site packaged in accordance with Table 6.0.

Rolls and panels of fabric forms are each wrapped in two layers of protective cover: the first layer (inner layer) is a waterproof, opaque, plastic cover the second (outer layer) is a woven, abrasion resistant, fabric cover (Fig. 17).

When fabric forms are to be inventoried at the job site, they should be kept dry and remain wrapped so that they are protected from the elements during storage and handling. If stored outdoors, they should be elevated and protected with a waterproof cover that is opaque to ultraviolet light. Care should be taken not to damage the fabric forms during unloading, storage and handling.

Note: *The contractor should unload the fabric forms by hand or with a forklift or similar equipment. When lifting rolls or panels of fabric forms make sure that workers have proper back support.*

Table 6.0 - Packaging of Fabric Form Rolls

Product	Filter Point (FP)	Filter Band (FB)	Uniform Section (US)	Enviromat (EL & EB)	Articulating Block (AB)
Roll Width, ft (m)	6.33 (1.92)	6.33 (1.92)	6.33 (1.92)	6.33 (1.92)	6.33 (1.92)
Roll Length, ft (m)	450 (137.2)	450 (137.2)	300 (91.5)	450 (137.2)	450 (137.2)
Gross Weight, lb (kg)	220 (100)	220 (100)	160 (72.7)	220 (100)	240 (109)
Area, ft ² (m ²)	2,848.5 (264.6)	2,848.5 (264.6)	1,899.0 (176.4)	2,848.5 (264.6)	2,848.5 (264.6)

Contraction of HYDROTEX linings and mats

Contraction factors are a function of site conditions and the fabric form lining or mat style. The definition of "contraction factor" is the length or width of fabric form required divided by the corresponding length or width of the area to be covered by the concrete lining or mat.

The contraction factors provided in Table 7.0 represent typical contraction factors developed by evaluating a large number of installations constructed over typical site conditions (Fig. 18). To use the contraction factors, measure the coverage area (including anchor, toe and flank trenches) and multiply by the contraction factor to obtain the dimensions of the form required.

Example Calculation: Calculate the quantity of Filter Point Fabric Form required for a 200 foot long by 33.2 foot wide mattress lining the drainage channel shown in Figure 19. The *length* of the panel spans the *width* of the channel to allow for more precise sizing. For simplicity in the example calculation, no allocation has been made for flank trenches in the calculation of the panel width.

Total Length of Panel

(spanning the width of the channel):

$$[2 (2.0 \text{ ft} + 1.5 \text{ ft}) + 2 ((2.5 \text{ ft})(\sin 26.6^\circ)^{-1}) + 15 \text{ ft}] = 33.2 \text{ ft (10.1 m)}$$

$$33.2 \text{ ft (10.1 m)} \times 1.1 = 36.5 \text{ ft (11.1 m)}$$

Total Width of Panel

(running along the length of the channel):

$$200 \text{ ft} \times 1.1 = 220 \text{ ft (67.1 m)}$$

Adjusting for mill widths multiples:

$$220 \text{ ft} / 6 \text{ ft} = 36.7 \text{ or } 37 \text{ mill widths}$$

$$37 \text{ mill widths} \times 6 \text{ ft} = 222 \text{ ft (67.7 m)}$$

Total Quantity of Fabric Form:

$$222 \text{ ft} \times 36.5 \text{ ft} = 8,103 \text{ ft}^2 (753.1 \text{ m}^2)$$

Note: Calculations should be done using the Mill Width and Mill Length factors given in Table 7.0. The Area factors are for rough estimating purposes only. Differing form geometries and the need to round up the width of the panels to mill width multiples can cause the area factors to be slightly inaccurate. In this example, 33.2 ft x 200 ft gives a coverage area of 6,640 ft². The actual panel area of 8,103 ft² is 1.22 times the coverage area.

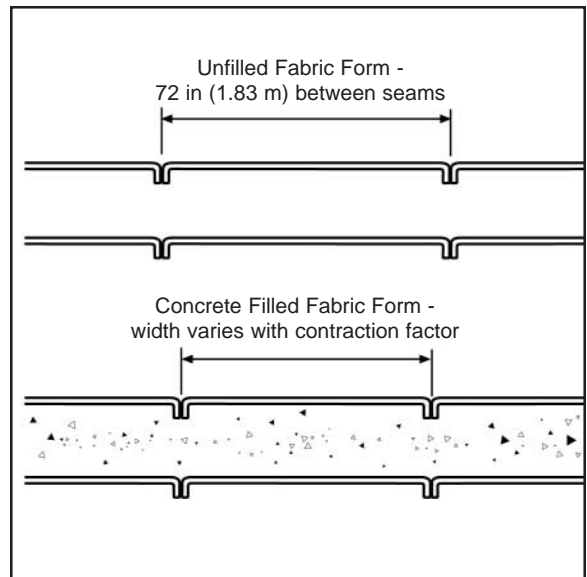

Figure 18

Notes:

The fabricated length dimensions of the fabric form panels are rounded up to the nearest one half foot (150 mm), except for Articulating Block Fabric Forms. Articulating Block Fabric Forms are rounded up to the next full compartment (block). The width dimensions of the panels are in mill width multiples of fabric form. Standard mill width is 72 in (183 mm). However, the width of the last panel in a section may be rounded up to the nearest half mill width.

Additional fabric may be required to allow for tailoring of panels to meet irregular site conditions. These factors range from two to ten percent.

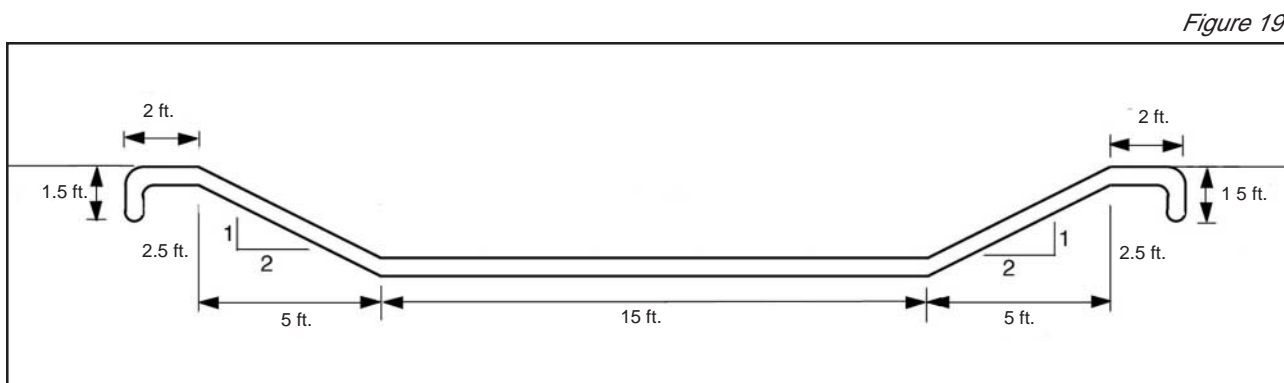

Figure 19

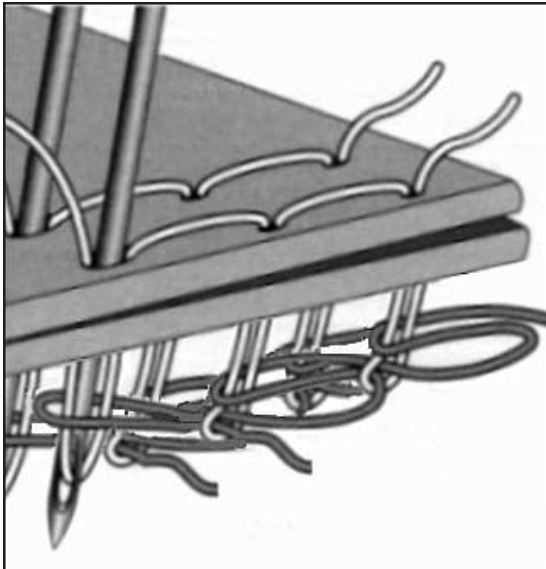

Figure 20

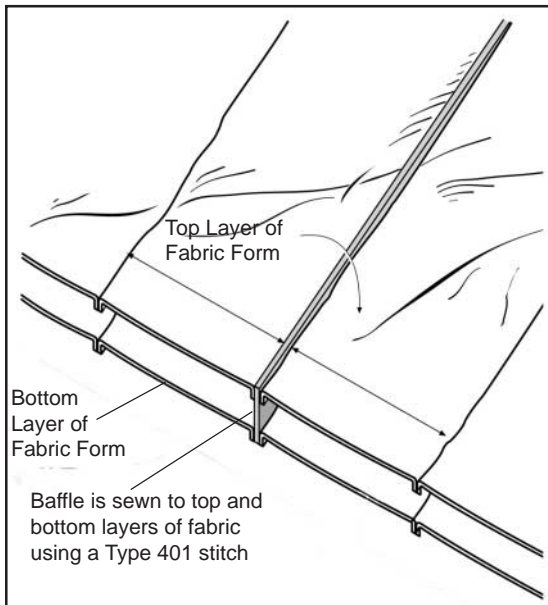

Figure 21

Factory Sewn Seams

All factory sewn seams are made with a double line of Type 401 double-lock stitches (Fig. 20) and are downward facing (Fig. 18). The downward facing seams provide a neat and continuous appearance in the finished fabric forms. All seams sewn in the factory shall be not less than 90 lbf/in (15.7 kN/m) when tested in accordance with ASTM D 4884. Thread used for seaming shall be nylon and/or polyester.

The fabric form panel's two layers of fabric are generally sewn closed along the panel's top and bottom edges (Fig. 15). The side edges of the panel are generally left open to enable field attachment of adjacent panels (Fig. 16). The contractor may request that zippers be attached to the top and bottom layers of fabric along the panel's open edges. The contractor attaches adjacent panels in the field by either sewing or zippering the open edges of fabric together.

Baffles

Baffles are installed at predetermined mill width intervals to regulate the lateral flow of fine aggregate concrete. The baffles are concrete stops made of nonwoven fabric. They extend from the top layer to the bottom layer of the fabric form at corresponding seams of adjacent mill widths (Fig. 21). The location of all baffles are specified on the shop drawings. Typically, baffles are installed every one to six mill widths apart, depending on the fabric form style, size and shape of the fabric form panel, and the project slope's steepness and length.

Irregular Panels

Non-rectangular fabric form panels are occasionally required to account for changes in slope elevations or length, to transverse around sharp curves and turns, and to fit around structures. (Standard rectangular panels may be "warped" around gradual curves or turns as described on page 23 of this manual.) When factory assembling irregular panels the lengths and offsets of individual mill widths of fabric form are dimensioned and cut to the nearest 0.5 ft (150 mm).

When Filter Point and Uniform Section panels are assembled to transverse around sharp curves or turns, panels are constructed with "mirror image" mill widths. Each of the panels will have one or more pairs of mill widths cut on a diagonal to the panel length. The matching sides of the mill widths are cut to obtain true angles and edges, then sewn together to form mitered seams. For Filter Band, Enviromat, and Articulating Block, please refer to page 25.

Table 7.0 - Typical Contraction Factors for HYDROTEX Linings and Mats

	Filter Point (FP)	Filter Band (FB)	Uniform Section (US)	Enviromat (EL)	Enviromat (EB)	Articulating Block (AB)
Mill Width	1.1	1.1	1.05	1.2	1.1	1.1
Mill Length	1.1	1.2	1.05	1.2	1.2	1.1
Area	1.21	1.32	1.1	1.44	1.32	1.21

Weep Tubes (for Uniform Section Linings)

Plastic weep tubes (drains) are pre-installed at designated locations, along the fabric forms, to relieve hydrostatic pressure (Fig. 22). The tubes have a flange at one end and a point at the other end of a 0.75 inch (19 mm) diameter barrel. The pointed end has four small holes that allow the passage of water but retain large soil particles. There is a flanged cap that is placed over the pointed end and locks in place. Weep tubes are available in lengths of 3, 4, 6, 8, and 10 inches (76, 102, 152, 203, and 254 mm) when measured between the assembled weep tubes flanges. The location of weep tubes, if required, are clearly marked on the fabric form panel shop drawings.

Weep tubes are assembled by forcing the pointed end of the weep tube through both the top and bottom layers of the fabric form and locking the flanged cap over the pointed end (Fig. 23). A small square of filter fabric can be placed over the in-place flanged cap and secured with a fastener (Fig. 24) or the fabric form can be placed over a continuous layer of filter fabric as shown in Figure 23. In either case the filter fabric should prevent fine soil particles from passing through the weep tube.

High-Strength Cable (for Articulating Block Mats)

High-strength cables should be constructed of high tenacity, low elongation, continuous filament polyester fibers. High-strength cables should have a core construction comprised of parallel fibers contained within an outer jacket or cover. The weight of the parallel fiber core should be 65 to 75 percent of the total weight of the cable. High-strength cables are available in a range of diameters and strengths (Table 8.0).

Table 9.0 provides the suggested high-strength polyester cable diameter for the range of Articulating Block Fabric Forms placed on slopes of different lengths. (AB 800, 1000, and 1200 should not be installed on slopes steeper than 1.5:1 except by experienced installers. Please contact Geostar Corporation for further technical assistance.)

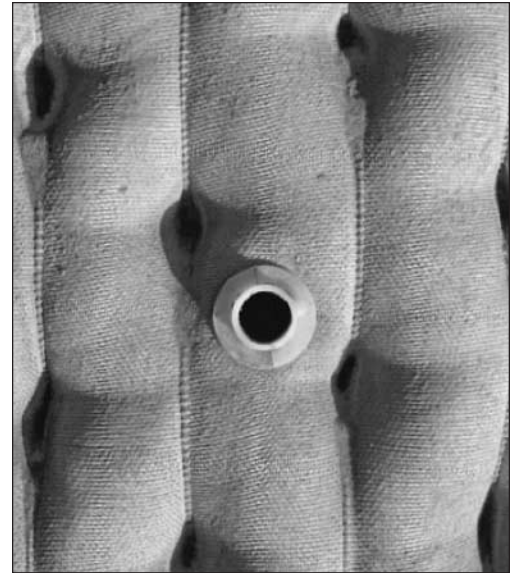

Figure 22

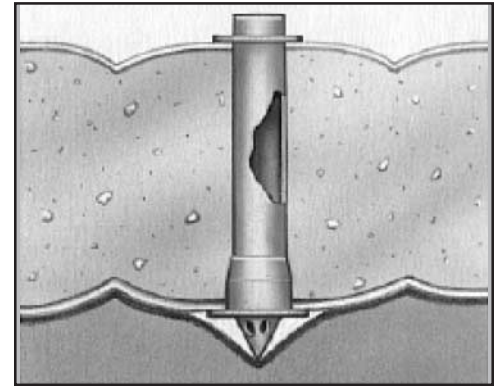

Figure 23

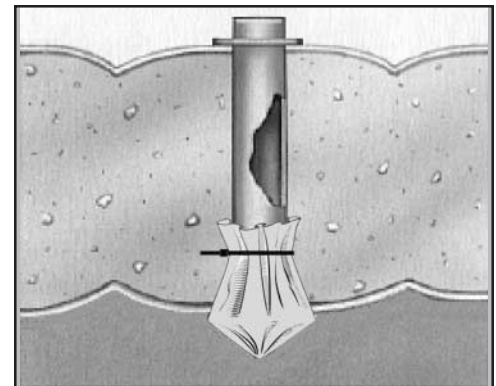

Figure 24

Table 8.0 - Nominal Dimensions, Strengths and Weights of High-Strength Polyester Cables

Cable Diameter, in (mm)	Weight Per 100 Linear Feet, lb (kg)	Average Breaking Strength, lbf (kN)	Maximum Allowable Working Load Per Cable, lbf (kN)
0.250 (6.35)	2.50 (1.13)	3,700 (16.47)	740 (3.29)
0.280 (7.11)	2.80 (1.27)	4,500 (20.03)	900 (4.00)
0.375 (9.53)	4.90 (2.22)	7,000 (31.15)	1,400 (6.23)
0.440 (11.2)	6.60 (2.99)	10,000 (44.50)	2,000 (8.90)
0.500 (12.7)	8.93 (4.05)	15,000 (66.75)	3,000 (13.35)
0.625 (15.9)	13.70 (6.22)	23,000 (102.35)	4,600 (20.47)

All dimensions and tensile strengths are average ± 5%.

Table 9.0 - High Strength Polyester Cable Selection Chart

Articulating Block Size	Slope	Slope Length, ft (m)								
		<20 (6.10)	30 (9.14)	40 (12.19)	50 (15.24)	60 (18.29)	70 (21.34)	80 (24.38)	90 (27.43)	100 (30.48)
		Average Breaking Strength of Polyester Cable, lbf (kN)								
AB400	5:1 - 2:1	3,700 (16.47)	3,700 (16.47)	3,700 (16.47)	3,700 (16.47)	3,700 (16.47)	3,700 (16.47)	3,700 (16.47)	3,700 (16.47)	3,700 (16.47)
	1.5:1	3,700 (16.47)	3,700 (16.47)	3,700 (16.47)	3,700 (16.47)	3,700 (16.47)	3,700 (16.47)	3,700 (16.47)	3,700 (16.47)	4,500 (20.03)
	1:1	3,700 (16.47)	3,700 (16.47)	3,700 (16.47)	4,500 (20.03)	7,000 (31.15)	7,000 (31.15)	7,000 (31.15)	10,000 (44.50)	10,000 (44.50)
AB600	5:1 - 2:1	3,700 (16.47)	3,700 (16.47)	3,700 (16.47)	3,700 (16.47)	3,700 (16.47)	3,700 (16.47)	3,700 (16.47)	3,700 (16.47)	3,700 (16.47)
	1.5:1	3,700 (16.47)	3,700 (16.47)	3,700 (16.47)	3,700 (16.47)	3,700 (16.47)	4,500 (20.03)	4,500 (20.03)	7,000 (31.15)	7,000 (31.15)
	1:1	3,700 (16.47)	4,500 (20.03)	7,000 (31.15)	7,000 (31.15)	10,000 (44.50)	10,000 (44.50)	15,000 (66.75)	15,000 (66.75)	15,000 (66.75)
AB800	5:1 - 2:1	3,700 (16.47)	3,700 (16.47)	3,700 (16.47)	3,700 (16.47)	3,700 (16.47)	3,700 (16.47)	3,700 (16.47)	3,700 (16.47)	3,700 (16.47)
	1.5:1	3,700 (16.47)	3,700 (16.47)	3,700 (16.47)	4,500 (20.03)	4,500 (20.03)	7,000 (31.15)	7,000 (31.15)	7,000 (31.15)	10,000 (44.50)
	1:1	3,700 (16.47)	7,000 (31.15)	7,000 (31.15)	10,000 (44.50)	15,000 (66.75)	15,000 (66.75)	15,000 (66.75)	23,000 (102.35)	23,000 (102.35)
AB1000	5:1 - 2:1	3,700 (16.47)	3,700 (16.47)	3,700 (16.47)	3,700 (16.47)	3,700 (16.47)	3,700 (16.47)	3,700 (16.47)	3,700 (16.47)	3,700 (16.47)
	1.5:1	3,700 (16.47)	3,700 (16.47)	7,000 (31.15)	7,000 (31.15)	7,000 (31.15)	7,000 (31.15)	10,000 (44.50)	10,000 (44.50)	10,000 (44.50)
	1:1	7,000 (31.15)	7,000 (31.15)	10,000 (44.50)	15,000 (66.75)	15,000 (66.75)	15,000 (66.75)	23,000 (102.35)	23,000 (102.35)	23,000 (102.35)
AB1200	5:1 - 2:1	3,700 (16.47)	3,700 (16.47)	3,700 (16.47)	3,700 (16.47)	3,700 (16.47)	3,700 (16.47)	3,700 (16.47)	3,700 (16.47)	3,700 (16.47)
	1.5:1	3,700 (16.47)	3,700 (16.47)	7,000 (31.15)	7,000 (31.15)	7,000 (31.15)	10,000 (44.50)	10,000 (44.50)	15,000 (66.75)	15,000 (66.75)
	1:1	7,000 (31.15)	10,000 (44.50)	15,000 (66.75)	15,000 (66.75)	23,000 (102.35)	23,000 (102.35)	23,000 (102.35)	23,000 (102.35)	NA

Requirements for Installing and Anchoring Liners and Mats

Slopes

The prepared areas should not be more than 2.5 inches (65 mm) below the grades indicated on the Contract Drawings, and should not vary more than 1.5 inches (40 mm) in 10 feet (3 m) as measured with a straightedge. Where such areas are underwater, they should be backfilled with crushed rock or stone conforming to the grading and quality requirements of 0.75 inch (20 mm) maximum size coarse aggregate for concrete.

Note: Though fabric-formed concrete can be installed on slopes steeper than those suitable for quarry stone or precast concrete blocks or for compacted soil or soil cement construction, fabric formed concrete linings and mats are not designed to improve slope stability. Their inherent weights are selected for the purposes of hydraulic stability and are not to be considered sufficient to impart stability to slopes subject to rotational, global or sliding failure or where severe consolidation of the subgrade is anticipated.

Flank, Anchor (side), and Toe Trenches or Aprons

Flank, anchor (side), and toe trenches or aprons should be excavated along the lines, grades and dimensions shown on the Contract Drawings. Trenching equipment works well provided the upper inside edge of the trench is rounded by hand in order that the fabric formed concrete lining or mat extends over a curve rather than a corner at the slope-to-trench transition (Fig. 25).

Crown Protection

Rivers and Channels

The top elevation of a fabric-formed concrete lining or mat installation should be extended to the top of the slope or to a point above the maximum design high water elevation plus a freeboard of a minimum of 2 ft (60 cm) with an additional allowance for run up from waves or boat wakes (Fig. 26).

It is recommended that fabric-formed concrete linings and mats should be extended horizontally at the top of the slope or onto a bench for a minimum distance of 2 ft (60 cm) and then placed in an anchor trench a minimum depth of 1.5 ft (50 cm) (Fig. 26). For sandy soils, a rounded shoulder and sloped trench side is normally used (Fig. 26.1).

Shorelines, Lakes, Reservoirs and Retention Basins

The top elevation of a fabric-formed concrete lining or mat installation should be extended to the top of the slope or to a point above the maximum run up from design waves or boat wakes (Fig. 27).

It is recommended that fabric-formed concrete linings and mats should be extended horizontally at the top of the slope or onto a bench for a minimum distance of 2 ft (60 cm) and then placed in an anchor trench a minimum depth of 2 ft (60 cm) (Fig. 27).

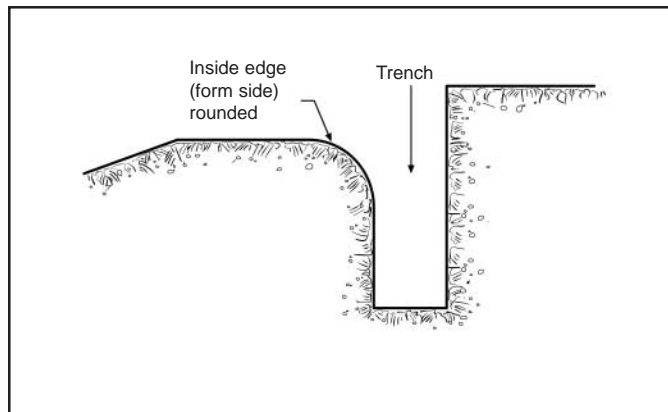

Figure 25

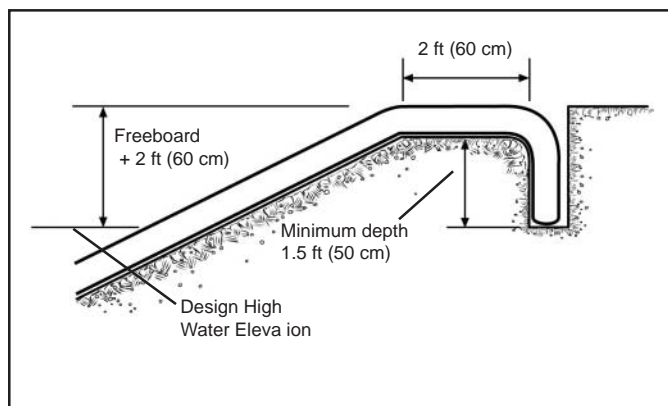

Figure 26

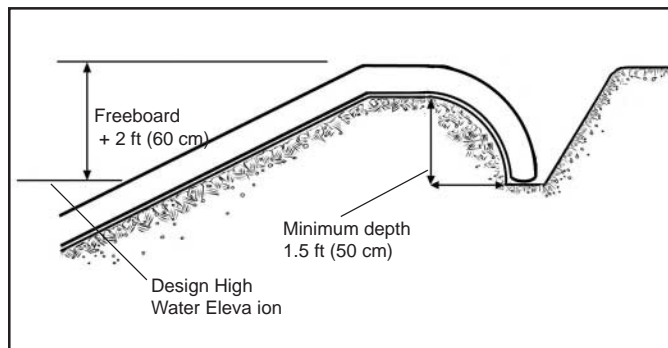

Figure 26.1

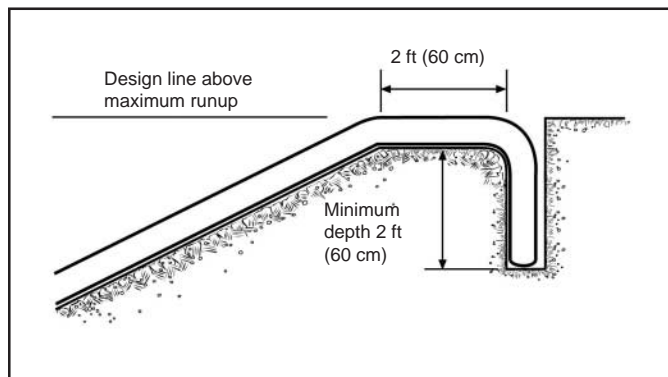

Figure 27

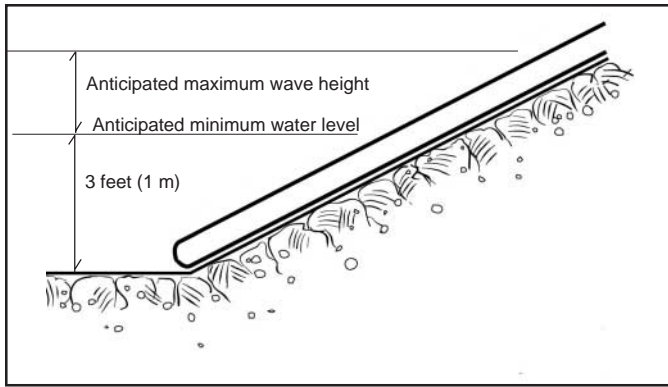

Figure 28

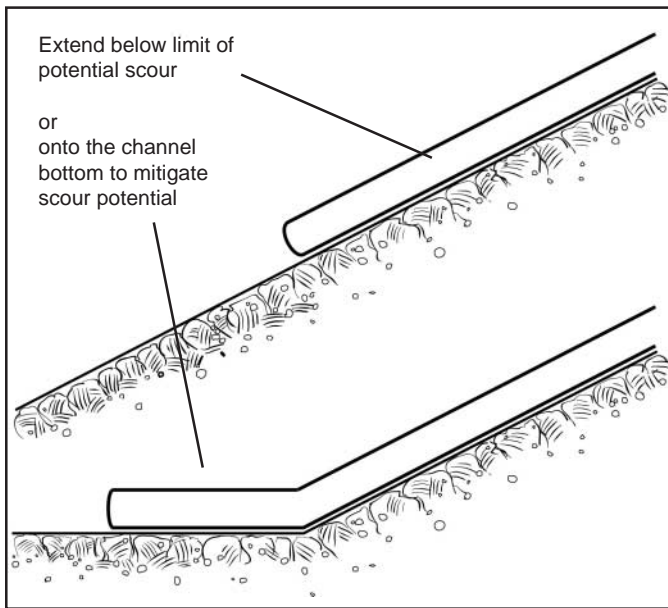

Figure 29

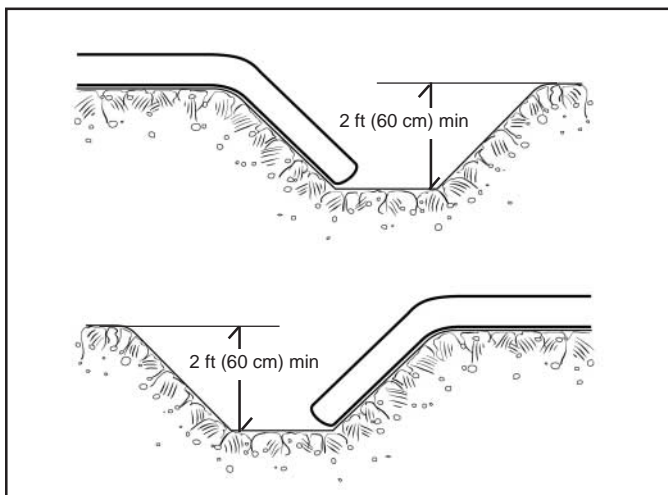

Figure 30

When constructing crown protection for either rivers and channels or shorelines, lakes, reservoirs and retention basins it is important to note that overtopping may cause erosion immediately above the protection that may eventually undermine and collapse the concrete linings, mats and armor units.

Toe Protection

The lower edges of a concrete lining or mat installation should be extended a minimum vertical distance of 3 ft (1 m) below anticipated minimum water level plus a distance equal to the anticipated maximum design wave height (Fig. 28). Additional toe protection may be required where the structure is in the vicinity of commercial shipping or where toe scour is known to be severe. The lower edge of the mat should extend to an elevation below that at which scour might occur or extend onto the channel bottom to mitigate scour (Fig. 29). This procedure will reduce the possibility of washout of soil from beneath the lining or mat.

Flank Trenches

The terminal ends of a fabric formed concrete lining or mat installation should be placed in a flank trench that is excavated at an angle of about 45° from the normal angle of the subgrade.

Rivers and Channels

Though the downstream flank of a concrete lining or mat installation is the most vulnerable point to the tractive forces of flowing water, it is recommended that both the downstream and upstream flanks be protected with flank trenches with a minimum depth of 2 ft (60 cm) (Fig. 30).

Shorelines, Lakes, Reservoirs and Retention Basins

Both flanks of a concrete lining or mat installation are equally vulnerable to the erosive forces of wave action and currents. They should both be protected with flank trenches with a minimum depth of 2 ft (60 cm) (Fig. 30).

Note:

The requirements listed on these pages for the anchoring and protection of linings and mats are given for guideline purposes only. For an actual installation, these parameters must be established by a qualified Hydraulics Engineer, based on his calculations of the requirements for a specific project. Geostar Corporation assumes no responsibility for the performance of an installation whose design has not been reviewed by a qualified engineer.

Installation of HYDROTEX Linings and Mats

Equipment and Tools

Because of the simple installation procedure for the HYDROTEX linings and mats, a nominal amount of tools and equipment is required. We suggest that the contractor have on hand the following:

Tools:

- Surveyor's level and rod
- Shovels
- Rakes
- Hammer
- Stakes
- String line
- Rubber boots and gloves
- Pail
- Trowels
- Safety glass or goggles
- Scissors
- Crimping tool (for Articulating Block only)

Equipment:

- Small line concrete pump
- Concrete pump hose - 2 inch (50 mm) diameter
- Injection pipe - 2 inch (50 mm) diameter (Fig. 31)
- Hand-held sewing machine (electric or air powered) with speed control
- Extension cord (if electrical equipment is used)
- Electric generator with ground fault circuit breaker
- Air compressor (if air powered sewing machine is used)
- Narrow trench digging equipment (optional)
- Small, walk-behind flat or vibratory compactor for soil compaction
- Post digger or auger (if steel anchor rods are specified)

Lists of equipment manufacturers are provided in the appendices. However, Geostar Corporation makes no warranty nor guarantees the performance of equipment provided by another manufacturer.

Sequence of Fabric Form Installation

Once the area to be protected has been excavated, graded and compacted to the lines and grades specified in the Contract Drawings and Specifications an installation crew, filter fabric, if required, fabric forms and the tools and equipment listed above should be mobilized to the job site. *Freshly excavated and graded slopes are highly subject to erosion and should be protected from water runoff, flowing water and waves.*

Depending on the location of the area, dimensions, and the rate of subgrade preparation, installation

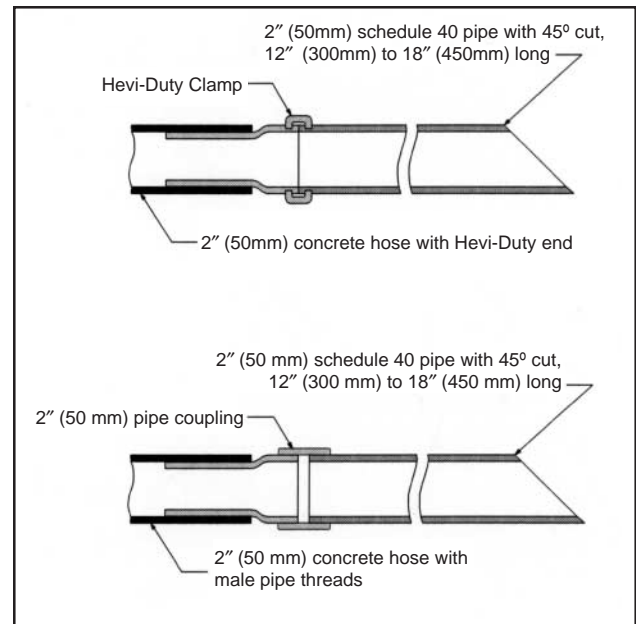

Figure 31

Equipment Traffic:

Equipment that could crack, cause abrasion, or otherwise damage the concrete should not be allowed on the installed fabric-formed linings and mats.

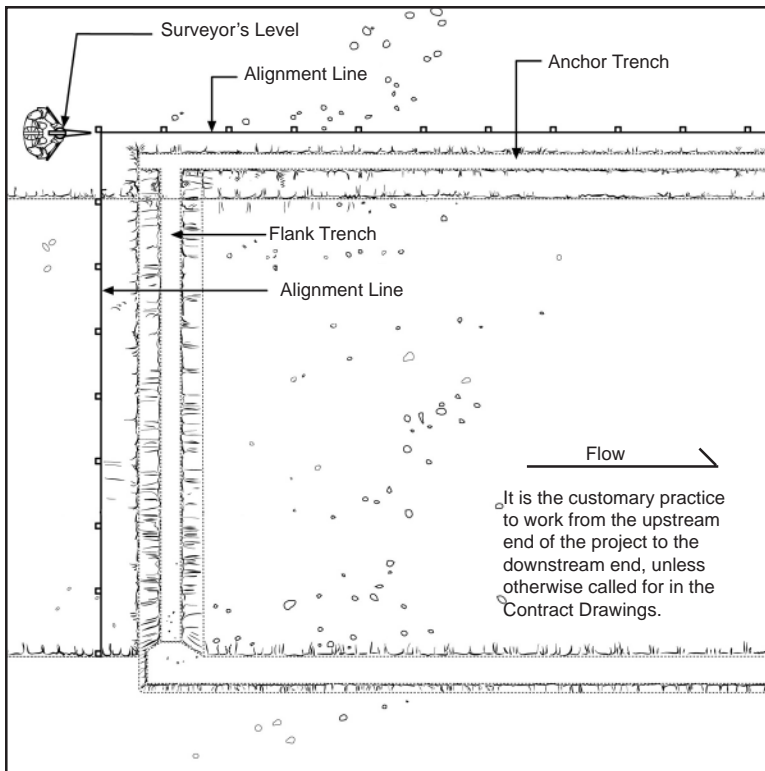

Figure 32

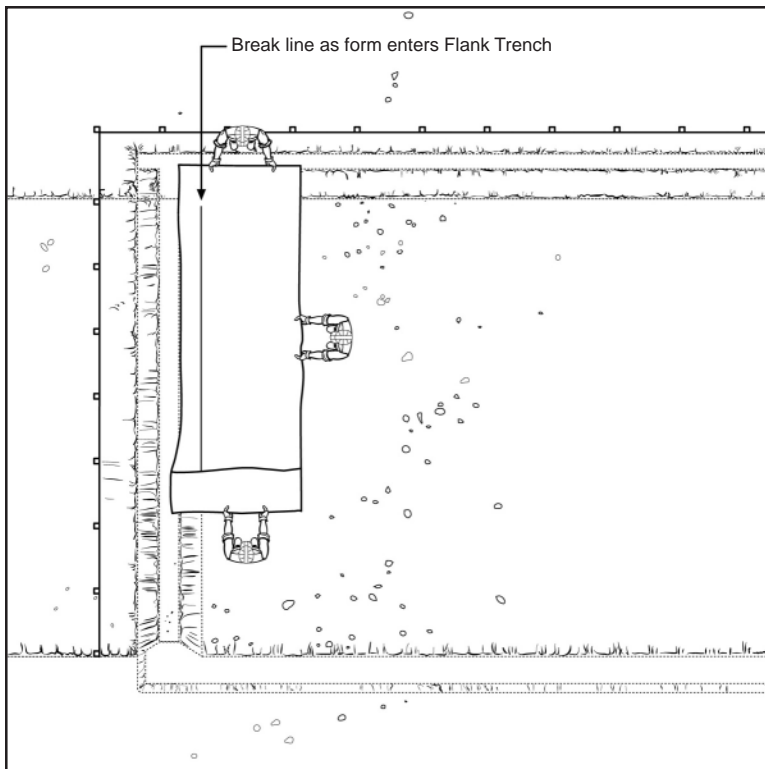

Figure 33

rates of as much as 15 yd³ (11.5 m³) of fine aggregate concrete per hour can be achieved by a crew of 3 or 4 laborers, a concrete pump operator and a supervisor.

Establish the starting point

The first step in the installation of fabric formed concrete linings and mats is to establish a starting point. If a working point and direction of placement are shown on the Contract Drawings this should be the starting point. If this is not the case, it is the customary practice to work from the upstream end of the project to the downstream end. In this manner the flow of the water will tend to spread the fabric forms out ahead of the finished work and the finished concrete lining or mat are protected from undercutting (Fig. 32). *Fabric form panel layout drawings, available from Geostar Corporation, will recommend starting points and directions of placement for the project.*

Establish the alignment lines

Once a starting point has been established a surveyor's level should be used to determine the longitudinal and slope alignment lines of the fabric formed concrete linings or mats (Fig. 32). String lines should then be placed along the respective alignment lines and staked. Generally, the alignment lines are offset, by a measured distance, to the opposite side of any trench or a minimum of 5 feet (1.5 m) in order not to interfere with the work area (Fig. 32). *The method of establishing reference points and lines should be left to the discretion of the contractor.*

Placement of the filter fabric, if required

Under certain soil conditions or if called for in the Contract Drawings and Specifications, it will be necessary to place filter fabric and/or a granular sublayer under the fabric forms to guarantee the functioning of the filter points, filter bands, permeable interwoven perimeters, or weep tubes. Filter fabric should be selected and placed in accordance with the Contract Drawings and Specifications or in the absence of such directions in accordance with the manufacturer's guidelines. If called for in the Contract Drawings and Specifications, steel anchor rods should be installed prior to placement of a geotextile filter fabric. The anchor rods should be forced through the filter fabric. *Filter fabrics and their installation are discussed, in brief, earlier in this manual.*

Placement of the first fabric form panel

The prefabricated panels are accordion folded and then rolled and marked with the appropriate panel numbers at the factory for easy identification, location and installation.

The first fabric form panel should be carefully placed at the designated starting point and rolled out into position (Fig. 33).

The panel should be extended into position by pulling the leading side of the panel in the direction of the concrete lining or mat placement (Fig. 34). Special care should be taken to assure that the sides and the ends of the panel are exactly parallel to their respective alignment lines.

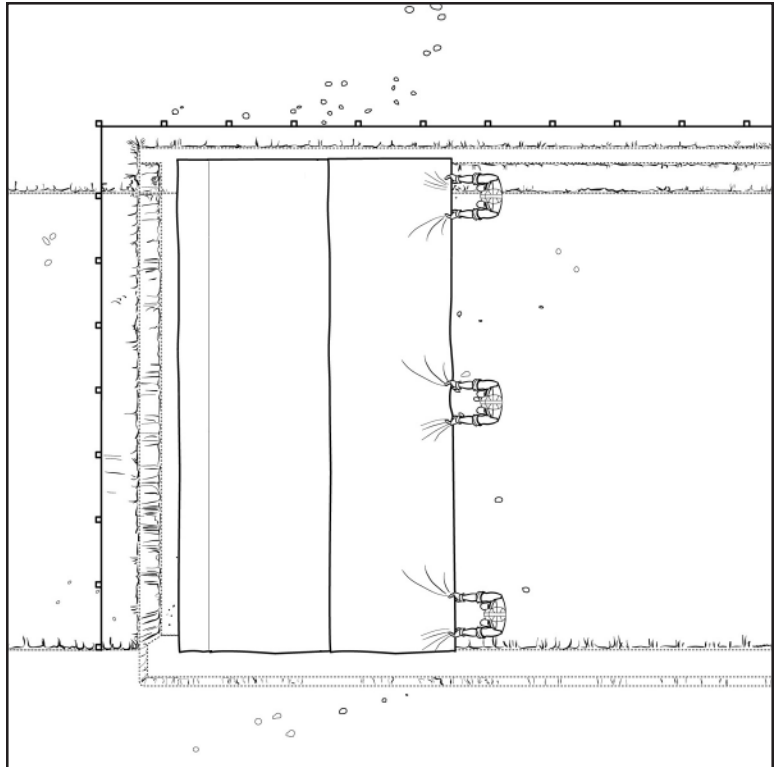

Figure 34

Fabric form panels should be placed loosely, but without folds, to allow for proper filling with fine aggregate concrete. The extra fabric form provided for form contraction should be gathered into temporary tucks at the top of the slope and at each seam (Figs. 35 and 36). Panels that are stretched or taut will not permit the required fabric contraction, therefore the fabric forms will not fill to their required thickness. For example, an 11 mill-width-wide panel of Filter Point fabric form will be 66 feet (20 m) wide. When filled with fine aggregate concrete the width will contract to a finished width of 60 feet (18 m). See Table 7 for the contraction factors of the various form styles. The fabric form in this example should therefore be placed with the seams (which join mill widths) 5.5 feet (1.6 m) apart. If called for in the Contract Drawings and Specifications, steel anchor rods should be forced through both layers of the fabric form.

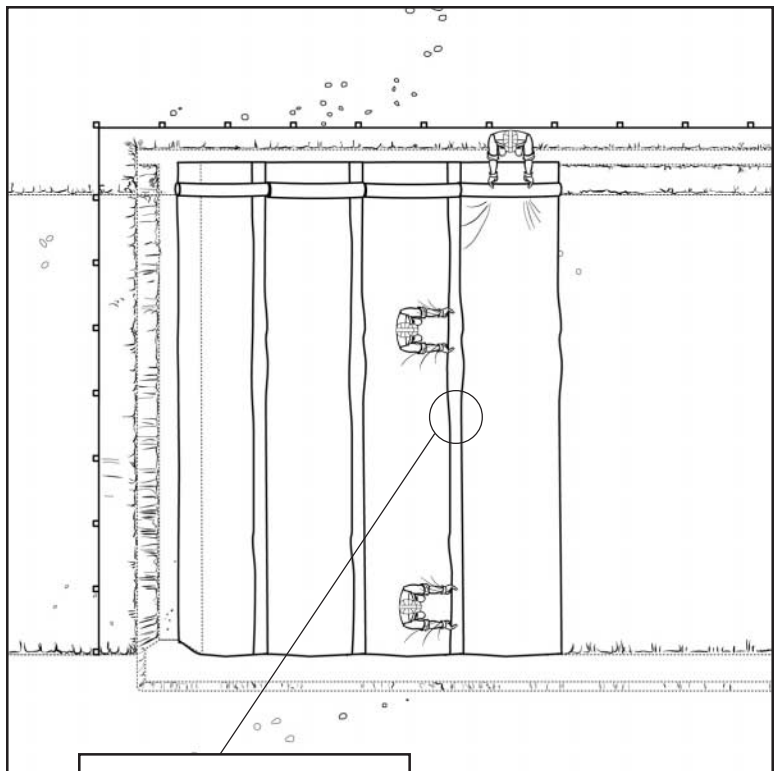

Figure 35

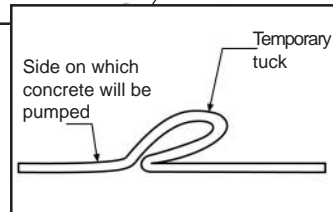

Figure 36 - Detail View of Tuck

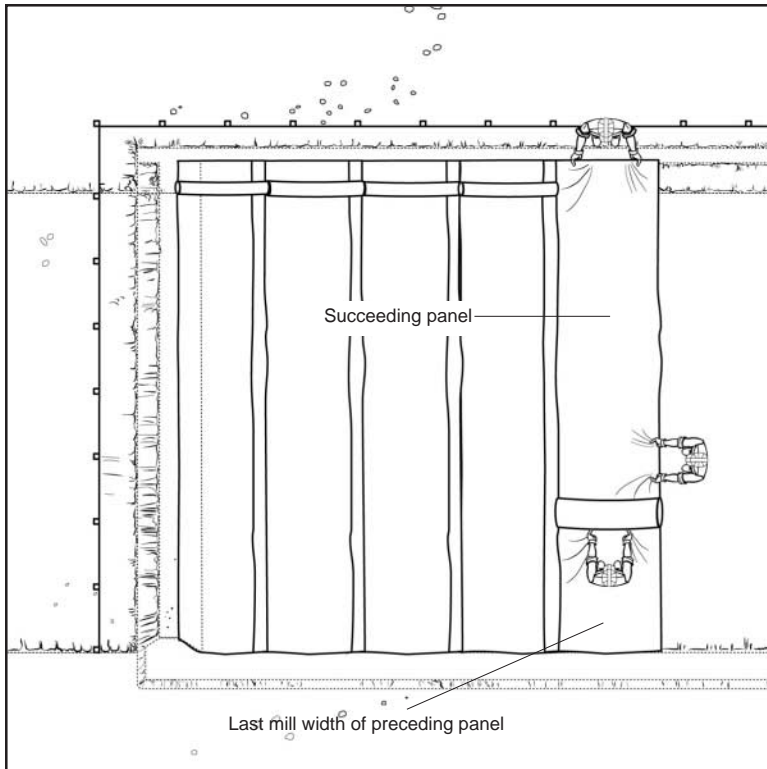

Figure 37

Placement of the second and remaining fabric form panels (sewn seams)

The succeeding panel should be placed atop the last mill width of the preceding panel so that their adjoining sides are abutting, as shown in Figure 37. The succeeding panel is then joined to the preceding panel by sewing. The panels should be joined together, edge-to-edge, by field sewing the top edge to top edge and the bottom edge to bottom edge (Fig. 38 and 39).

Placement of the second and remaining fabric form panels (zippered seams)

The succeeding panel should be placed adjacent to the last mill width of the preceding panel so that their adjoining sides are abutting. The succeeding panel is then joined to the preceding panel by zipping the panels together (Fig. 40).

Note: When installing Articulating Block (AB) Fabric Forms, optional transverse cables are spliced together prior to joining the second layers of fabric.

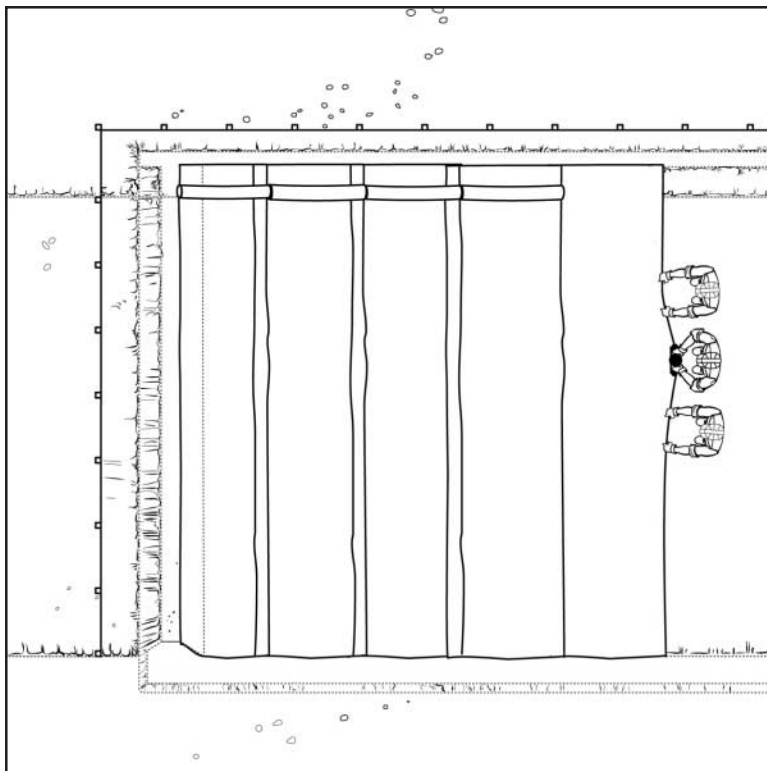

Figure 38



Figure 39 - Sewing Fabric Panels

Figure 40 - Zippering Fabric Panels



- **The second panel** should then be extended in the direction of alignment and all seams should be downward facing (Fig. 41). After the second panel has been positioned, the alignment of the panels should be checked. The alignment of the fabric should be checked periodically since small errors in alignment can progress in severity.
- **The remaining panels** should be placed side-by-side in the same manner. If care has been taken in placing the panels, little if any further adjustment of panels should be required. However, panel alignment is important in providing a uniform and attractive appearance in the finished installation.

Fabric form placement should proceed concrete filling by no more than the distance that can be completed in one day.

If the panels are to be placed underwater or if the aesthetic appearance is not of importance, the time involved in inverting the panels as described above may not be justified. Adjacent panels may be joined by abutting the panels and sewing the bottom and then the top seam. Except for the small tab of fabric that will protrude above the surface of the concrete lining or mat, seaming the fabric in this manner is functional and will not adversely effect the performance of the installation.

Sewn seams should be made using portable, hand-held, sewing machines and nylon or polyester sewing thread. Generally, a prayer seam with a U.S. Federal Standard Type 101 stitch is the most suitable. It is strongly recommended that each seam be made with two parallel passes of the sewing machine to assure a tight seam equivalent to those seams sewn in the factory. *Whenever possible, the second pass of the sewing machine should run in the direction opposite to but parallel to the first pass.*

Three (3) laborers are generally required for the sewing or zippering of seams; one to operate the sewing machine or zipper pull, one to align the fabric form and one to inspect the seam.

Sewing machines suitable for field use are listed in Appendix 2. There are both electric and air powered sewing machines listed. The electric sewing machines should be provided with a speed control rheostat. The air powered sewing machines have a built-in speed control. The air powered machines are more expensive; however, they are safer when working in a wet environment.

All seams sewn in the field shall be not less than 90 lbf/in (15.7 kN/m) when tested in accordance with ASTM D 4884. Colored thread is preferable for seams, since defects such as broken threads, seams too close to the edge of the fabric or a machine that is skipping are immediately apparent.

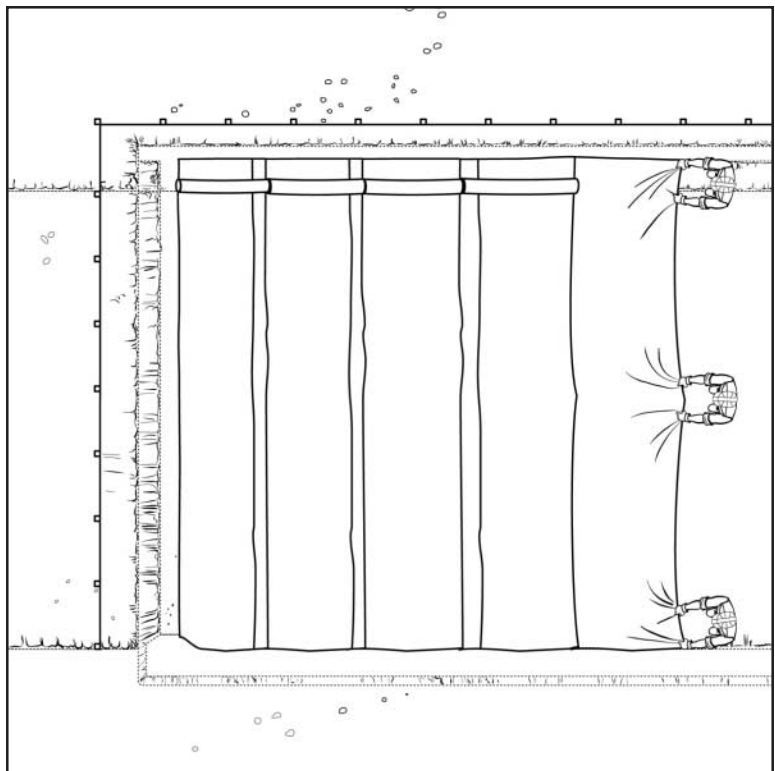

Figure 41

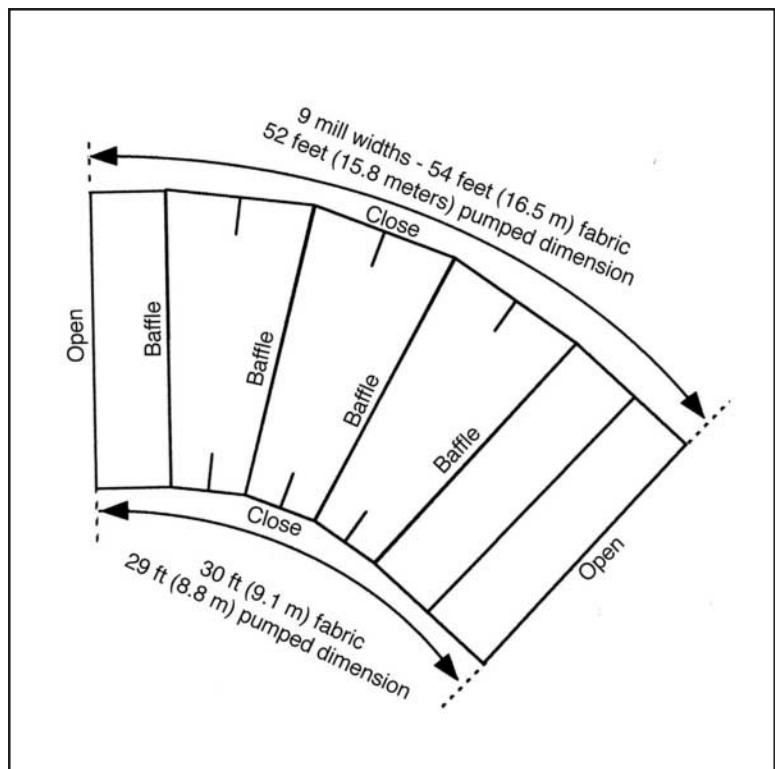

Figure 42

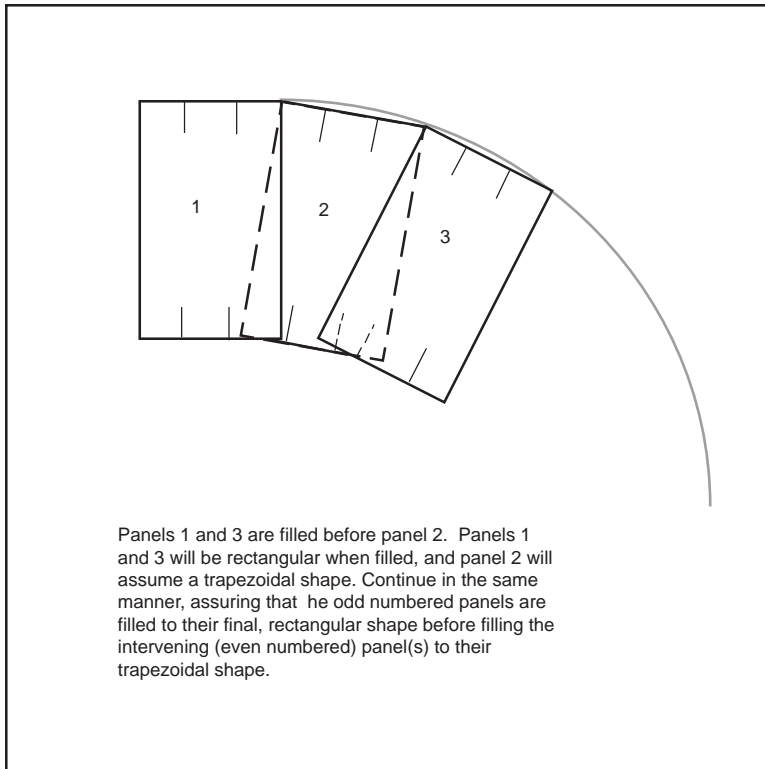

Figure 43

Placement of fabric form panels around curves and turns

Curves or turns may be accomplished by panels with one or more angled mill widths. Panels with angled mill widths should be carefully prefabricated or field assembled by cutting and sewing the mill widths of the fabric form(s) to obtain true angles and edges (Fig. 42).

Curves and turns in the project can also be accomplished by positioning the sides of alternate panels perpendicular to the concrete lining or mat's longitudinal alignment line. The alternate panels should then be pumped to form standard rectangular shaped sections. The intermediate panels should then be pumped. These intermediate panels will form sections with a slightly trapezoidal shape to complete the curve or turn (Fig. 43).

A third method to accomplish curves and turns in the project is to place baffles between each mill width. Then set predetermined seams at one end of the mill width at their normal spacing at cord points along the larger radius of the curve or turn and then set the seams at the other end of the panel at a measured spacing at cord points along the smaller radius of the curve or turn. The excess width of fabric form, between seams, is carefully accumulated into pleats that taper the mill width down toward the smaller radius (Fig. 44).

Placement of fabric form panels into trenches

After the fabric form panels have been positioned, the designated sides of the panels should be folded into the anchor trench, flank trenches and toe trench.

Underwater placement of fabric forms may require the use of divers. The divers can prepare the finished grading, inspect the area to be protected, and position and secure the filter fabric and fabric forms. The securing of the fabric may require sand bags or weights, or lines tied from shore to hold the fabric in position.

A small quantity of bulk (uncut and unassembled) fabric form should be ordered for each project. This fabric can be used for special field tailoring around drains, headwalls and field changes requiring extensions to pre-assembled panels. At least half a roll, about 900 ff² (84 m²), of bulk fabric is recommended.

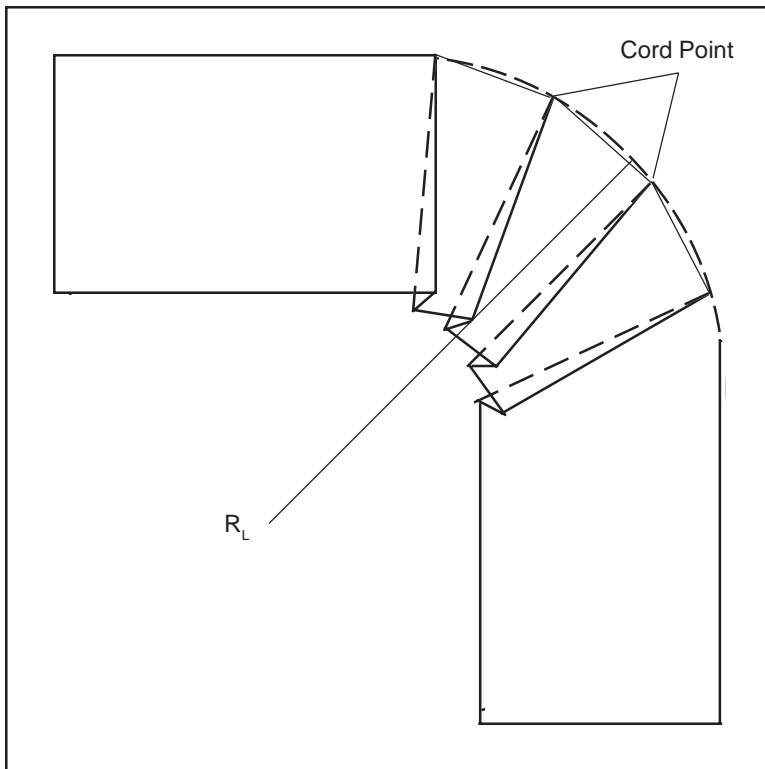

Figure 44

Sequence of Fine Aggregate Concrete Pumping

Ordering fine aggregate concrete

Fine aggregate concrete is generally delivered to the job site in ready-mix trucks. The order for concrete should be placed a least one day prior to its scheduled delivery to the job site. The concrete supplier should be instructed to fill the water tank of each truck with mix water. *It is common that the first few loads delivered to the job site will not be fluid enough for pumping and will require the addition of mix water.* In order to avoid presetting of the fine aggregate concrete it is recommended that the concrete be delivered in loads of no more than 8 yd³ (6 m³). At a minimum, the first load of each day should be checked with a standard flow cone for consistency, in accordance with ASTM D 6449.

Securing the fabric form panels

Beginning at the designated starting point the installation crew should check and adjust the fabric form panel's seams to assure that they are perpendicular to the longitudinal alignment line. After the panel has been properly adjusted fine aggregate concrete is either pumped into the portion of the fabric form panel that has been placed into the anchor trench (Fig. 45) or the form is secured to structures such as a retaining walls, abutments or curbs. *Insert a pipe or reinforcement bar through a hem sewn along the top edge of the fabric form and secure the pipe or bar to an anchor (Fig. 46).* Securing the panel should help control the position of the panel and should prevent the freshly filled fabric form from sliding down the slope. *It must be emphasized that care should be exercised in the alignment and securing of the first fabric form panel. This will ensure the aesthetics of the concrete lining or mat and also hasten the installation of subsequent panels. Fabric should be placed loosely at the connection or anchor to allow for contraction in both directions during filling.*

Inserting the fine aggregate concrete injection pipe

Fine aggregate concrete should be pumped into the fabric form panel by inserting the injection pipe through a small slit cut in the upper layer of fabric (Fig. 47). *Care must be taken not to cut through the bottom layer of the fabric form.* A tight seal should be made by wrapping a piece of nonwoven fabric

Safety:

All on site personnel should wear safety hats, glasses or goggles, rubber gloves and boots at all times. Electric equipment should be provided with ground fault circuit interrupters and circuit breakers. Concrete pumps and hoses should be handled with care and operated in strict accordance with their manufacturer's safety instructions.

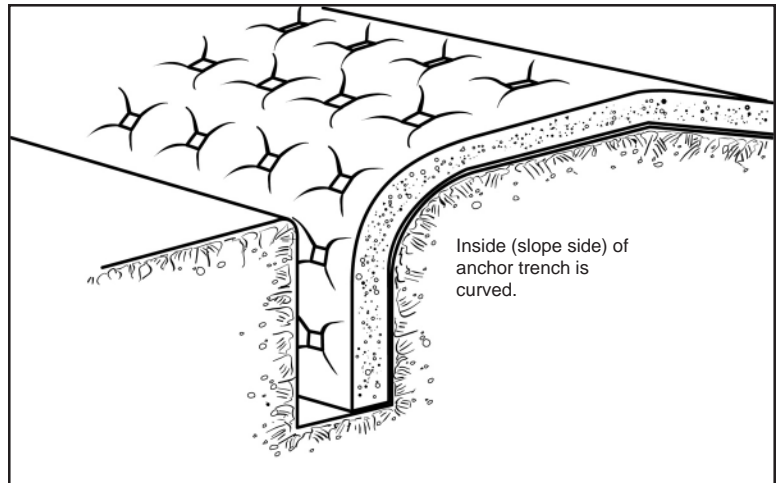

Figure 45

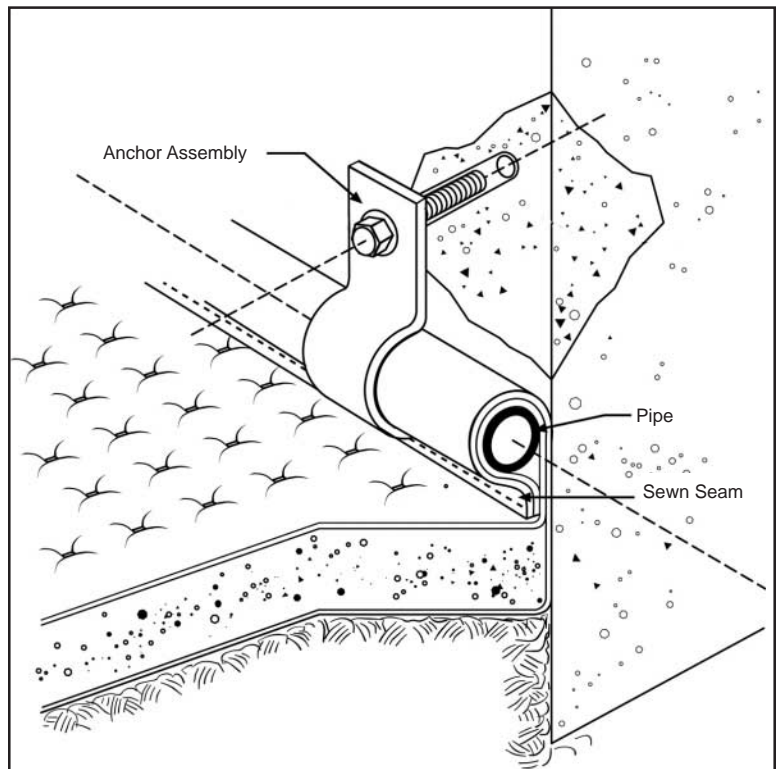

Figure 46



Figure 47

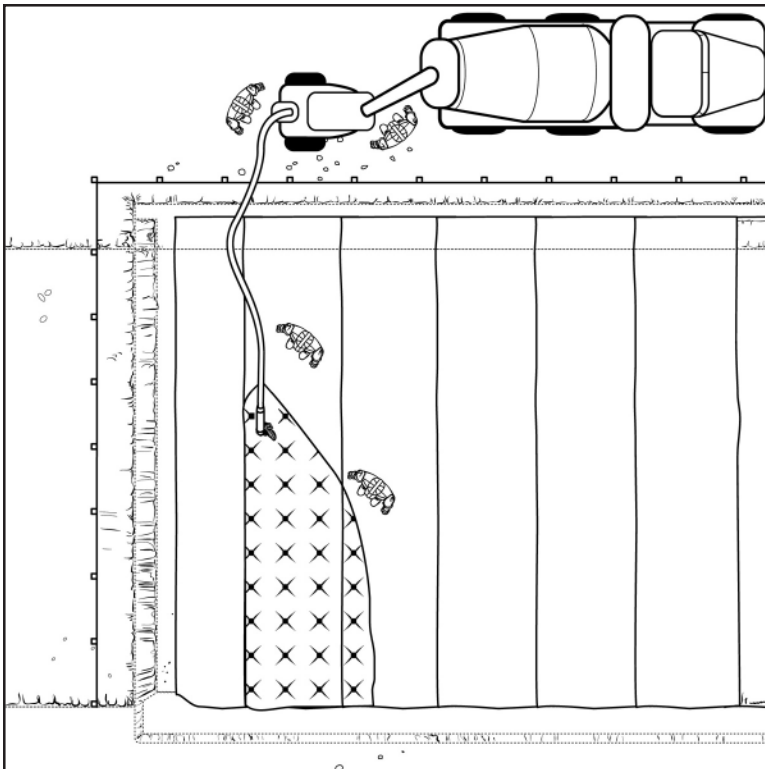

Figure 48

around the pipe. When the pipe is withdrawn, the nonwoven fabric should be stuffed into the hole to provide a temporary closure. When the concrete has stiffened and is no longer fluid, the fabric should be removed and the concrete surface should be smoothed by hand.

Filling the first fabric form panel with fine aggregate concrete

The first section of the first panel has generally been placed into a flank trench. In order to eliminate the sliding of the panel into the trench during fine aggregate concrete filling, the general practice is to first fill the second section of the first panel, to anchor the fabric. Starting at the second section of the first panel, the injection pipe should be inserted at a point near the inside of the first baffle and a measured distance along the length of the panel. (See Table 10.0.)

The second panel section should be filled by pumping fine aggregate concrete between the panel's top and bottom layers of fabric. The flow of fine aggregate concrete should be directed toward the toe or lower end of the panel (Fig. 48).

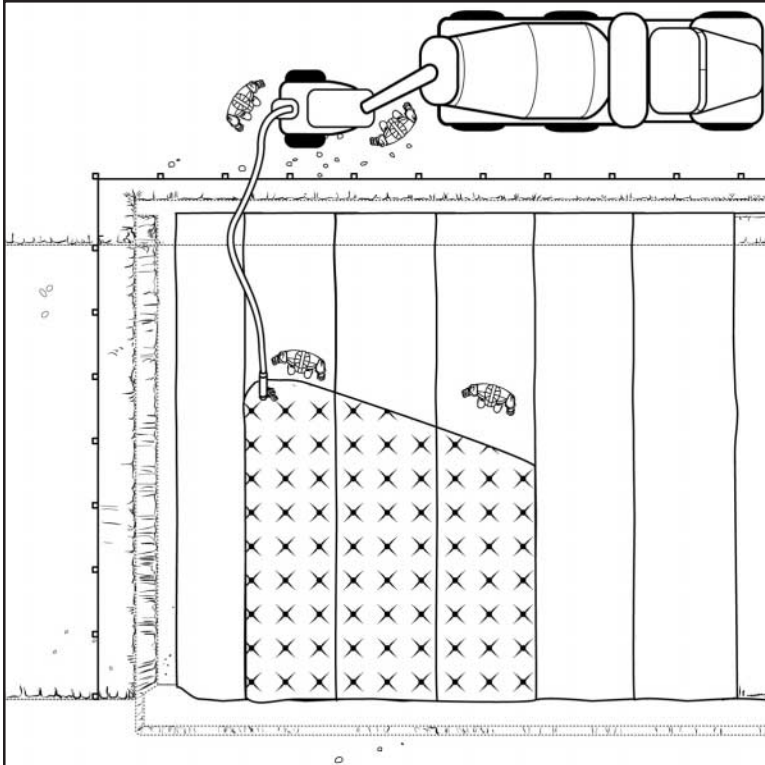

Figure 49

The fine aggregate concrete should fill the toe or lower end of the panel, proceeding gradually up and laterally across to the second baffle of the panel and to an elevation not less than 2 feet (500 mm) above the point of concrete injection (Fig. 49). *Pressure from the concrete fill helps to seal off the point of concrete injection.* If the point of concrete injection is not at the crown of the slope, the injection pipe is reinserted further up the panel and the flow of concrete is once again directed down the panel. *Experienced installation crews are able to pump to an elevation above the point at which the concrete injects.*

Wetting down of fabric forms:

As fine aggregate concrete is pumped into the fabric forms, excess mixing water will be expelled through the fabric and the concrete will stiffen rapidly. When pumping fabric forms with relatively thin cross-sectional thickness, down a long slope, across a wide section or on a relatively flat surface above water, it may be desirable to wet down the fabric prior to pumping concrete.

Table 10.0 - Maximum Distance Between Injection Points, Measured Along the Length of the Panel (ft/m)

Slope		4:1	3:1	2:1	1:1
Product	Size	L	L	L	L
Filter Point	220	35 (10.7)	46 (14)	65 (19.8)	75 (22.9)
	400	64 (19.5)	75 (22.9)	65 (19.8)	41 (12.5)
	600	69 (21.0)	53 (16.2)	37 (11.3)	24 (7.3)
	800	39 (11.9)	30 (9.1)	21 (6.4)	13 (4.0)
	1000	32 (9.8)	24 (7.3)	17 (5.2)	11 (3.4)
	1200	20 (6.1)	15 (4.6)	11 (3.4)	7 (2.1)
Filter Band	400	64 (19.5)	75 (22.9)	70 (21.3)	63 (19.2)
	800	55 (16.8)	42 (12.8)	30 (9.1)	19 (5.8)
	1200	26 (7.9)	20 (6.1)	14 (4.3)	9 (2.7)
Uniform Section	300	48 (14.6)	63 (19.2)	70 (21.3)	75 (22.9)
	400	64 (19.5)	70 (21.3)	75 (22.9)	64 (19.5)
	600	75 (22.9)	64 (19.5)	45 (13.7)	28 (8.5)
	800	33 (10.1)	25 (7.6)	18 (5.5)	11 (3.4)
	1000	22 (6.7)	17 (5.2)	12 (3.7)	10 (3.0)
	Enviromat EL	250	40 (12.2)	52 (15.9)	70 (21.3)
	400	64 (19.5)	75 (22.9)	60 (18.3)	38 (11.6)
Enviromat EB	300	48 (14.6)	63 (19.2)	75 (22.9)	67 (20.4)
	500	80 (24.4)	67 (20.4)	48 (14.6)	30 (9.1)
Articulating Block	400	60 (18.3)	65 (19.8)	70 (21.3)	75 (22.9)
	600	65 (19.8)	70 (21.3)	75 (22.9)	56 (17.1)
	800	75 (22.9)	70 (21.3)	61 (18.6)	38 (11.6)
	1000	70 (21.3)	54 (16.5)	38 (11.6)	24 (7.3)
	1200	53 (16.2)	40 (12.2)	29 (8.8)	18 (5.5)

Using Tables 10.0 and 10.1 -

First use Table 10.0 to determine the maximum length along the panel between injection points, based upon the slope angle and the product being used. Table 10.1 will then allow you to determine the maximum number of panel widths. Select the length to be pumped along the bottom axis and note where that intersects with the curve for each product thickness. Then read the maximum number of mill widths along the vertical axis. Round to the next highest mill width.

Over pressuring of fabric forms:

Care must be taken, when pumping fabric forms to assure that the fabric is not over pressurized. Over pressurization may cause bursting of filter points, bands or interwoven perimeters or may cause rupturing of interwoven drop cords. The style of the fabric form and field conditions will often determine the rate of vertical rise of the concrete that may be realized in pumping. Table 10.0 provides typical guidelines for pumping fabric forms. For the ease of measurement in the field, the vertical rise in concrete has been converted to slope length.

Table 10.1 - Maximum Distance between Injection Points, measured along the width of the panel (in mill widths)

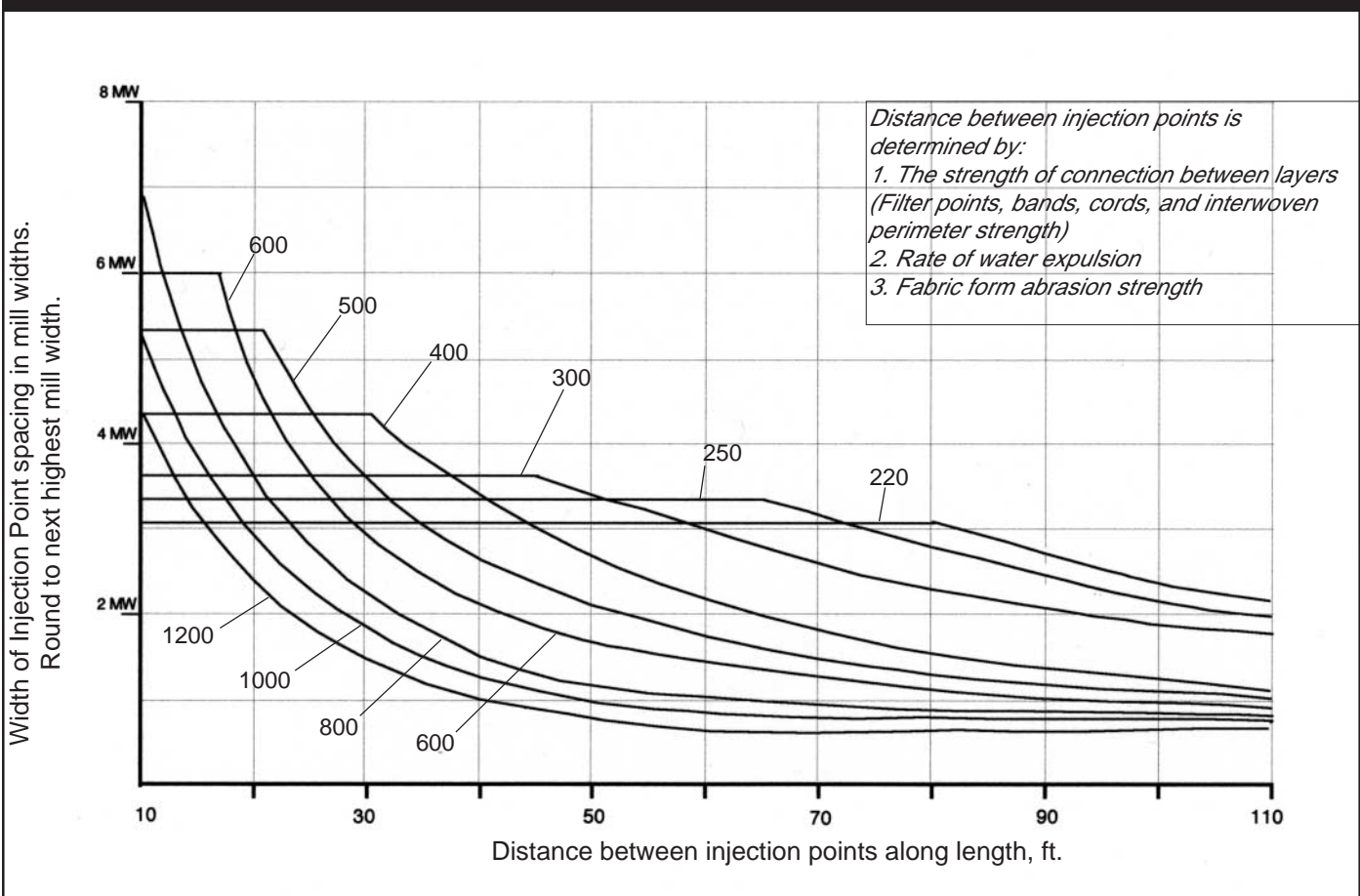

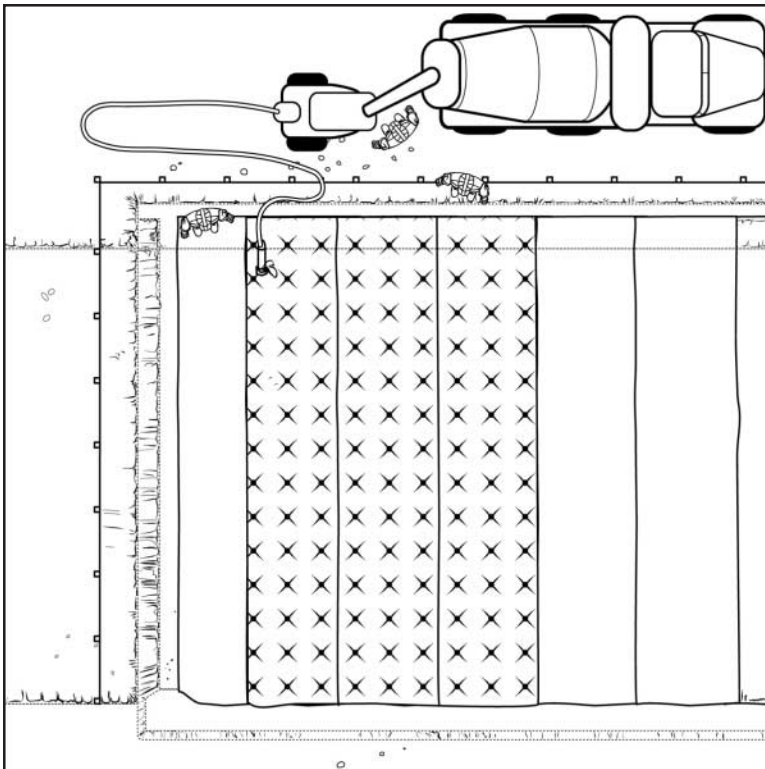

Figure 50

This procedure is repeated until the second section of the first panel has been filled to its specified thickness from baffle to baffle and from the toe or lower end to the anchor trench or top end (Fig. 50).

When installing fabric formed linings or mats on steep slopes or when the installation crew is inexperienced, it is recommended that they first fill the fabric form that has been placed in the anchor trench then proceed to directing the flow of fine aggregate concrete to the toe or lower end of the panel.

As the fabric form panel is being pumped with fine aggregate concrete the panel will contract causing a stretching and tightening of the form. In order to prevent the tightening of the fabric form and the resulting constriction of fine aggregate concrete flow, the installation crew should slowly release the temporary tucks previously placed in the fabric form at the top of the panel. *The temporarily tucks may be accumulated at the top of the panel and held in place by standing on the fabric form. As tension develops the fabric tucks are slowly released.*

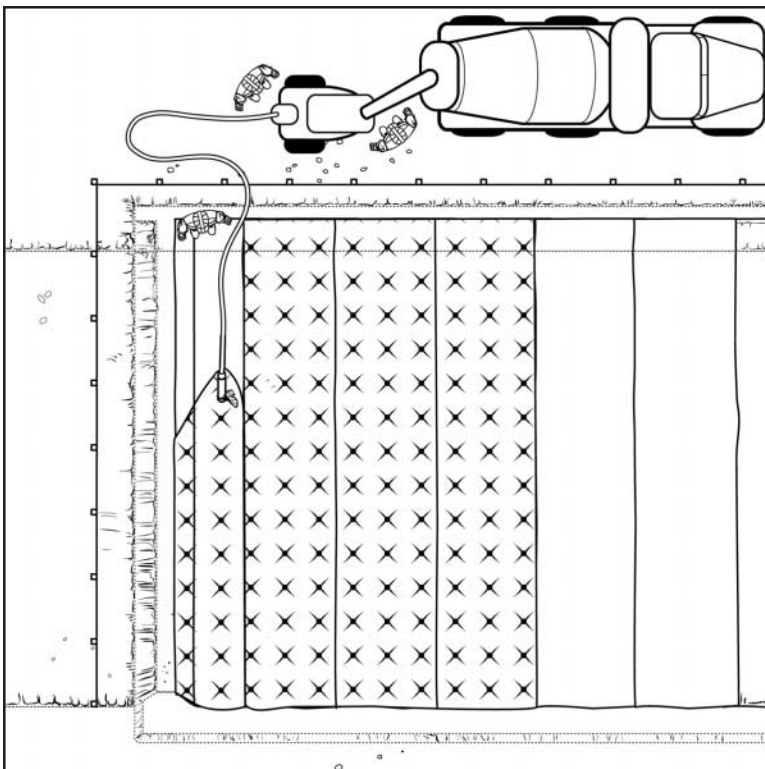

Figure 51

The injection pipe should then be moved to the other side of the first baffle and inserted at a point near the baffle and a measured distance along the length of the panel (Fig. 51). Once again the previous pumping procedure should be repeated until this section of the panel has been filled to its specified thickness from baffle to baffle and from its toe or lower end to its anchor trench or top end.

Filling remaining fabric form panels with fine aggregate concrete
If care has been taken in positioning the panels and in concrete filling the first panel, little if any adjustment of subsequent panels should be required. However, panel alignment should be checked periodically since small errors in alignment can progress in severity. Periodically check the location of the panels with an instrument to assure that proper alignment is being maintained.

Special Considerations

Lap Joints

If the conventional joining of panels, by field sewing of adjacent panels, is impractical or if site conditions or project design preclude a continuous lining or mat a lap joint may be employed. Adjacent panels may be overlapped either transverse to or longitudinal to the installation. In all cases the lap must be shingled to correspond with the direction of flow.

A lap joint may be desirable along the centerline of a wide channel or a channel with changes in bottom width or slope length. It may allow the contractor the flexibility to use a standard panel size to conform to the variable design cross sections.

A lap joint may be constructed by overlapping adjacent fabric form panels by a minimum of 3 feet (1 m). **Butt joints are not permitted.** The proper method for constructing a lap joint is the following pumping sequence (Fig. 52):

- Fill the next to the last mill width of the upstream form, leaving the last section of the upstream and preceding panel unpumped.
- Excavate a terminal trench as described in Figure 52 or in the Contract Drawings.
- Position the side of the succeeding panel approximately 3 feet (1 m) from the last pumped mill width of the preceding panel.
- Pump fine aggregate concrete into the first mill width of the succeeding panel.
- Backfill the terminal trench so that the last mill width of the preceding panel can be laid to form an even transition to the succeeding panel.
- Extend the last mill width of the preceding panel over the indented portion of the first mill width of the succeeding panel and fill this section.

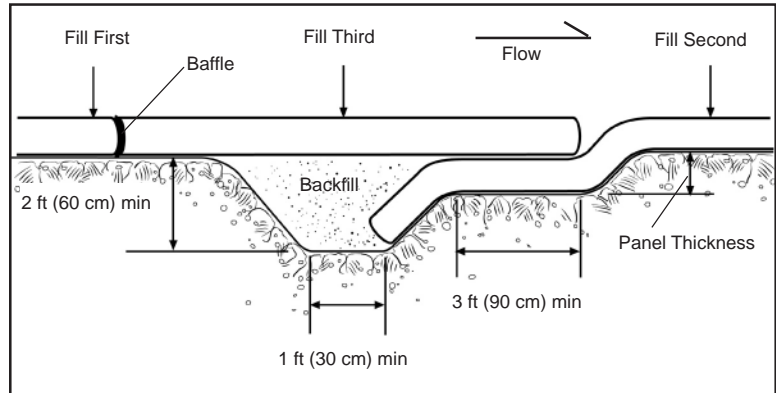

Figure 52

Pipes, piles, culverts, trees and other appurtenances

Fabric forms should be tailored in the field to fit around pipes, piles, culverts, trees and other appurtenances. An opening should be cut in the fabric form that is slightly smaller than the object and the perimeter of the opening is sewn closed. When the fabric form panel is placed the tailored opening is either slid over or wrapped around the object. As fine aggregate concrete is pumped into the section of the panel with the tailored opening it will form snugly around the object (Fig. 53).

An alternate method of construction is to first fill the fabric forms that have been placed in close proximity to the object and then to place a separate collar, snugly around the object, overlapping the primary concrete lining or mat by a minimum of 2 ft (60 cm) (Fig. 54).

Backfilling and compaction of trenches

The backfilling and compaction of anchor, flank and toe trenches and other open excavations should proceed in not less than one hour behind the concrete filling of the fabric formed linings or mats. Anchor and flank trenches should be backfilled and compacted to the top of the concrete linings or mats. Toe trenches should be backfilled as shown on the Construction Drawings. *The trenches of completed sections of concrete linings or mats should be backfilled and compacted by the end of the work day.*

Foot traffic

Foot traffic on the freshly pumped fine aggregate concrete lining or mat should be avoided for a period of not less than one hour after concrete injection or until the concrete is resistant to indentation. Should traffic be unavoidable, the contractor should place board walks along the finished filled concrete areas. This will reduce the amount of objectionable indentation. *Footprints will leave permanent impressions in the installed fabric-formed concrete linings or mats.*

Cleanup

Any fine aggregate concrete that may spill on top of the fabric formed concrete lining or mat should be picked up by hand or trowel and the surface



Figure 53

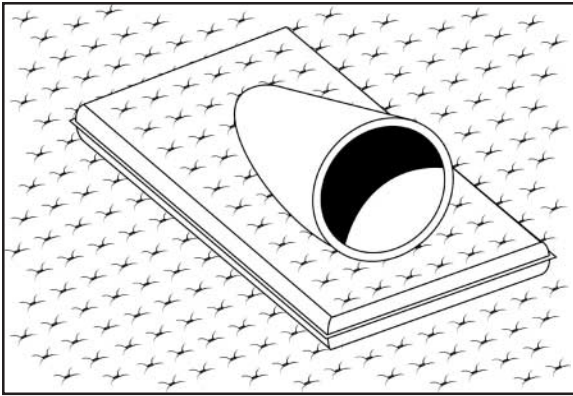

Figure 54

smoothed by cloth or broom. Such unnecessary spillage of concrete will cause an unsightly appearance and may clog the concrete lining or mat's drainage areas such as filter points, filter bands or the permeable interwoven perimeter areas of the fabric forms. *The installation crew should be instructed to carefully "kink" the concrete pump hose when it is moved from one injection point to another or to place the end of the concrete injection pipe in a pail when moving the concrete pump hose.*

The freshly pumped fabric formed concrete linings and mats should never be washed (sprayed) under pressure with water in an effort to clean or remove spills from its surface. A wet cloth should be used for clean up and spill removal.

The cement film that bleeds through the top layer of the fabric forms provides a bond between the fabric form and the concrete fill and a degree of protection against ultraviolet degradation of the fabric. Should this film be removed by washing the uncured concrete linings or mats, cement may be also washed out from beneath the top layer of fabric. The result would be a loss of concrete-to-fabric bond, a sandy, low strength outer surface of concrete and a concrete lining or mat which will exhibit low abrasion resistance and durability.

Finishing (Enviromat EL & EB Linings only)

After the concrete lining has been filled and the concrete has set, the large single-layer areas should be cut out and the resulting open areas filled with void filler to the top of the concrete lining. The void filler material should consist of topsoil, seed and fertilizer in accordance with the Contract Specifications. At no time should more than 200 linear feet (152.5 m) of concrete lining be exposed unfilled.

Below the water line, the void filler material should consist of well-graded aggregate with a maximum size of 1 inch (25 mm). At no time shall more than 500 linear feet (150 m) of Enviromat be exposed unfilled.

Steel Anchor Rods

Where required in the Contract Drawings and Specifications, steel anchor rods should be installed at designated centers along the fabric-formed concrete lining or mat to increase its resisting force (Fig. 55). The diameter of the anchor rods is selected to provide the supplemental shear strength required for the installed area of lining or mat. The threaded anchor rods should be grades 40 or 50 and a 6 inch (152 mm) square washer and nut are placed at the end of each anchor. Typically, the total length of the anchor rod is the sum of the embedment depth, the average thickness of the lining or mat, plus 6 inches (152 mm). The embedment depth of the anchor rod must be sufficient to resist the pullout force applied in line with the rod. The depth is dependent upon the concrete used in the anchor block and the type of soil. *For most conditions, an embedment depth of 24 inches (610 mm) is sufficient.*

Anchor rods are installed by excavating a 6 inch (152 mm) diameter anchor hole with a post digger or auger, filling the hole with concrete, and inserting the anchor rod. Once the concrete has set, a geotextile filter fabric and the fabric form are placed and the anchor rod is forced through the filter fabric and both layers of the fabric form. The form is filled with fine aggregate concrete and allowed to set for a minimum of one hour. A washer is then placed over the exposed end of the anchor rod, and a nut is installed snugly to secure the washer to the top of the lining or mat.

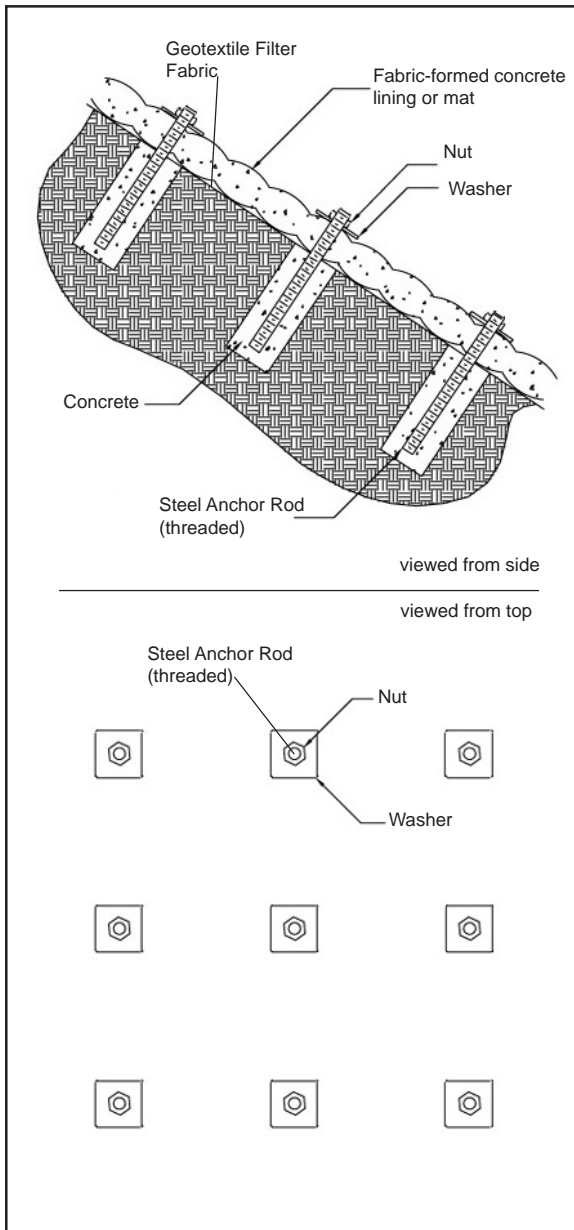

Figure 55

HYDROCAST™ Armor Units

HYDROCAST fabric forms provide an effective forming system for casting large concrete armor units in place, underwater or in-the-dry. Fabric formed concrete armor units meet the requirements for a reliable and economical cast-in-place alternative to heavy quarry stone (rip rap) or large precast concrete blocks. They are used for the construction and repair of erosion control structures such as breakwaters, dikes, seawalls, groins, and jetties as well as for foundation structures (such as underwater pipelines), footing supports, and other hydraulic and marine structures. They are also extensively used by departments of transportation to prevent or repair scour at bridge piers and abutments. Figures 56, 57, 58, and 59 illustrate typical applications of fabric-formed armor units.

When filled with a fine aggregate or conventional concrete they form individual, cylindrical units that assume a flattened cross section, as demonstrated in figures 56 and 57. The concrete is pumped under pressure, resulting in rapid concrete stiffening, improved concrete properties [e.g., “case hardening” of the outer 3 to 6 inches (75 to 150 mm) of concrete], strength and durability. They have the required mass and stability to withstand the severe forces of large storm waves and rapidly flowing water. The concrete armor units may be placed side-by-side or stacked to form an inherently interlocked structure. Since they are concrete filled in place, they can adapt to variations in the subgrade or bottom contours.

Fabric-formed concrete armor unit installations do not require dewatering, a crucial advantage in emergency repair of bridge piers scoured by flood waters. Fabric forms can be positioned and filled with concrete from the surface in shallow water or by divers in deeper water. Unlike quarry stone or precast concrete blocks, they do not require placement by heavy cranes working from the land or from barges.

Fabrication of HYDROCAST Armor Unit Forms

The specially woven double-layer fabric is joined by a perimeter of interwoven and/or sewn seams to form a large fabric form envelope. Fabric used in the construction of armor units shall conform to the physical properties shown in Table 11.0. All sewn seams are folded and sewn with a double line of Type 401 double-lock stitches. The sewing thread used for seaming shall be nylon or polyester. Each fabric form is provided with one or more self-closing inlet valves to accommodate a concrete injection pipe.

HYDROCAST Unit Dimensions

Fabric-formed concrete armor units may be cast in a wide range of sizes and shapes. Geostar’s technical staff accurately calculates the length, width and height of the concrete armor unit and the volume of concrete per measure of unit length with the aid of computer programs. Tables 12.0 and 13.0 provide typical dimensions and volumes of fabric-formed concrete armor units, both filled and unfilled.

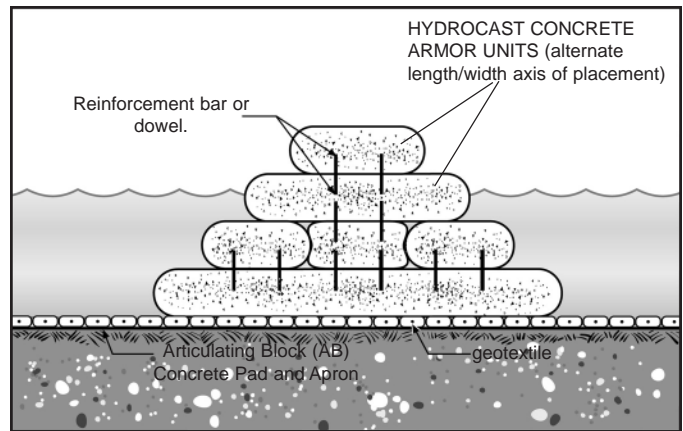

Figure 56 - Groin

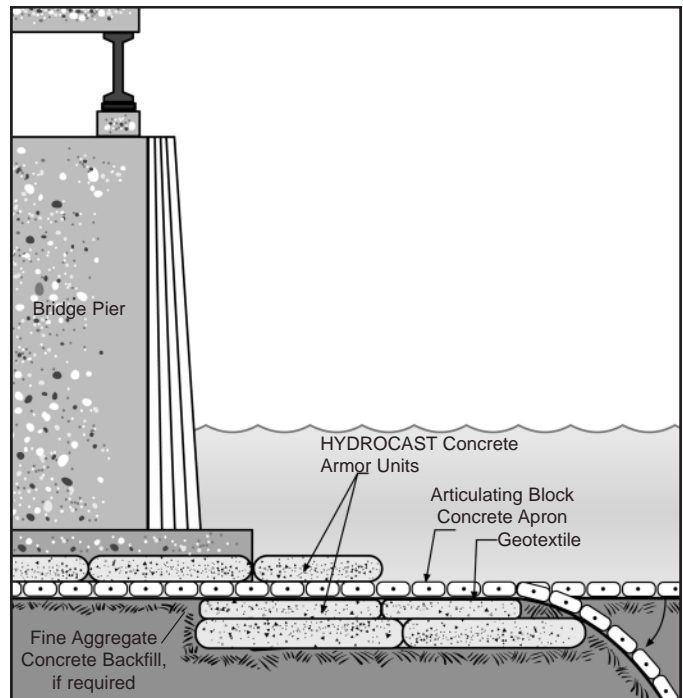

Figure 57 - Repair of Scoured Bridge Pier

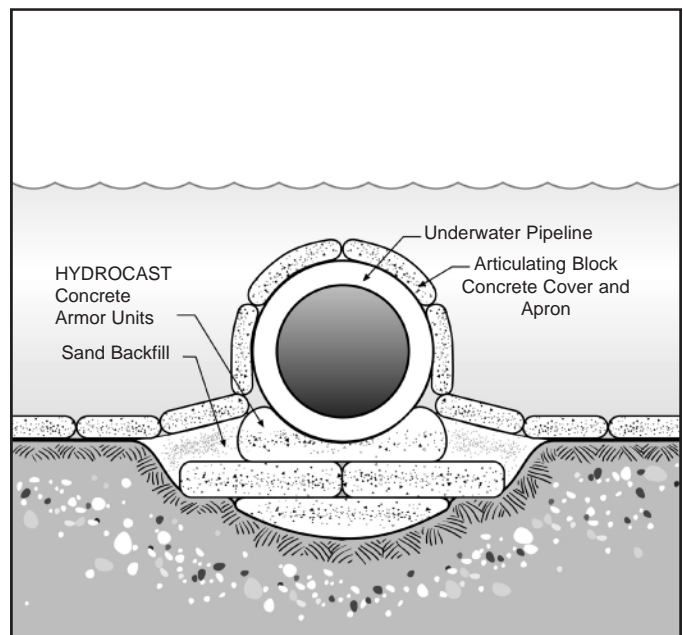

Figure 58 - Pipeline Saddle and Cover

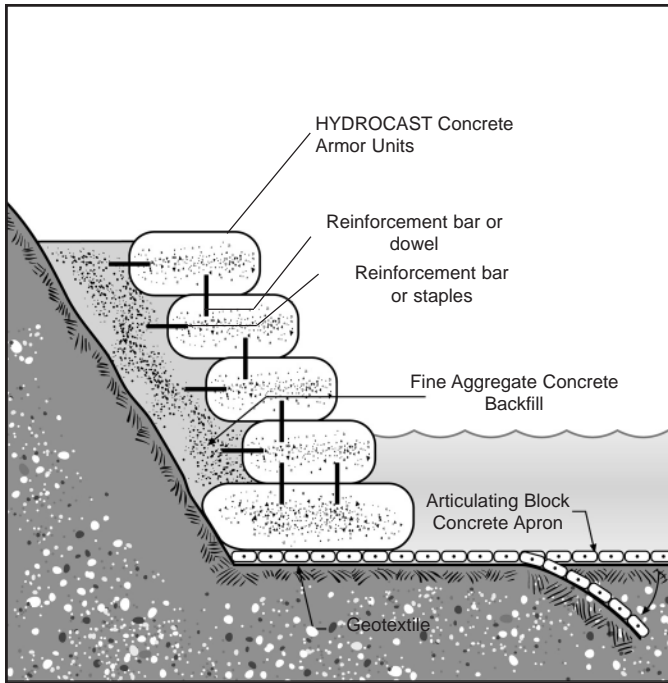

Figure 59 - Seawall or Shoreline Protection

Custom Designs

In addition to the wide range of standard rectangular fabric formed concrete armor units, Geostar's designers can also design custom shaped forms to accommodate underwater pipelines, footers and other objects (Fig. 60).

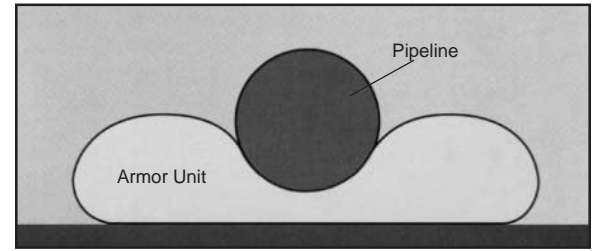

Figure 60

Table 11.0 - Property Requirements - HYDROCAST Armor Unit Fabric ^{1, 2}			
Property	Test Method	Units	Values
Physical:			
Composition of Yarns			Nylon or polyester
Mass Per Unit Area (double-layer)	ASTM D 5261	oz/yd ² (g/m ²)	14 (470)
Thickness	ASTM D 5199	mils (mm)	28 (0.7)
Mill Width		in (m)	76 (1.92)
Mechanical:			
Wide-Width Strip Tensile Strength - Machine/Cross	ASTM D 4595	lbf/in (kN/m)	190 (33.2) / 140 (24.5)
Elongation at Break - Machine/Cross	ASTM D 4595	%	20 / 30
Trapezoidal Tear Strength - Machine/Cross	ASTM D 4533	lbf (N)	180 (800) / 115 (510)
Hydraulic:			
Apparent Opening Size (AOS)	ASTM D 4751	U.S. Standard Sieve (mm)	60 (0.250)
Flow Rate	ASTM D 4491	gal/min/ft ² (l/min/m ²)	50 (2035)

Notes:

1. Conformance of fabric to specification property requirements shall be based on ASTM D 4759, "Practice for Determining the Specification Conformance of Geotextiles."
2. All numerical values represent minimum average roll values (i.e., average of test results from any sample roll in a lot shall meet or exceed the minimum values). Lots shall be sampled according to ASTM D 4354, "Practice for Sampling of Geosynthetics for Testing."
3. Yarns used in fabric construction shall not contain partially oriented (POY), draw-textured, and or staple yarns.

Ordering Fabric Forms

The ordering of fabric forms should be done in advance of the start of the project, to allow time for the preparation, submittal and approval of layout and shop drawings. Project plans and specifications should be submitted to Geostar's technical support department. Trained technicians translate the site plans, grades, elevations, contours and construction details into CAD systems where they develop cost-effective take-offs and fabric-formed concrete armor unit layout drawings, tailored to the project's design requirements. This design technique and CAD layout verification procedure will assure accurate dimensioning and quantity material takeoffs.

The forms are over-dimensioned, in both length and width, to make allowance for form contraction as they are filled with fine aggregate concrete. Contraction factors are a function of site conditions and finished armor unit dimensions. The definition of "contraction factor" is the length or width of fabric form required divided by the corresponding length or width of the area to be covered by the concrete armor

Manufacturer's Certification:

The manufacturer of the fabric forms should submit a manufacturer's certificate stating that the supplied fabric forms meet the criteria of the manufacturer's specifications, as measured in full accordance with the test methods and standards referenced. The certificates should include the following information about each fabric form shipment:

- *Manufacturer's name and current address*
- *Full product name*
- *Style and product code number*
- *Form number(s)*
- *Polymer types*
- *Manufacturer's certification statement*

Table 12.0 - Unfilled Fabric Form Width/Length to Filled Thickness and Width/Length of Armor Unit																	
Filled Thickness	Width/Length of Unfilled Fabric Forms																
inches	24	30	36	42	48	54	60	66	72	78	84	90	96	102	108	114	120
meters	0.61	0.76	0.91	1.07	1.22	1.37	1.52	1.68	1.83	1.96	2.13	2.29	2.44	2.59	2.74	2.90	3.05
	Width/Length of Filled Fabric Forms - Inches (Meters)																
6 0.15	21 0.52	27 0.68	33 0.83	39 0.98	45 1.13	51 1.28	57 1.14	63 1.59	69 1.74	75 1.89	81 2.05	87 2.20	93 2.35	99 2.50	105 2.66	111 2.81	117 2.96
9 0.23	19 0.48	25 0.63	31 0.78	37 0.94	43 1.09	49 1.24	55 1.39	61 1.55	67 1.70	73 1.85	79 2.00	85 2.16	91 2.31	97 2.46	103 2.61	109 2.77	115 2.92
12 0.30	17 0.44	23 0.59	29 0.74	35 0.89	41 1.05	47 1.20	53 1.35	59 1.50	65 1.66	71 1.81	77 1.96	83 2.11	89 2.26	95 2.42	101 2.57	107 2.72	113 2.87
15 0.38		21 0.52	27 0.68	33 0.83	39 0.98	45 1.13	51 1.28	57 1.44	63 1.59	69 1.74	75 1.89	81 2.05	87 2.20	93 2.35	99 2.50	105 2.66	111 2.81
18 0.46			26 0.65	32 0.81	38 0.96	44 1.11	50 1.26	56 1.42	62 1.57	68 1.72	74 1.87	80 2.03	86 2.18	92 2.33	98 2.48	104 2.63	110 2.79
21 0.53				30 0.76	36 0.92	42 1.07	48 1.22	54 1.37	60 1.52	66 1.68	72 1.83	78 1.98	84 2.13	90 2.29	96 2.44	102 2.59	108 2.74
24 0.61					34 0.87	40 1.02	46 1.18	52 1.33	58 1.48	64 1.63	70 1.79	76 1.94	82 2.09	88 2.24	94 2.40	100 2.55	106 2.70
27 0.69						39 0.98	45 1.13	51 1.29	57 1.44	63 1.59	69 1.74	75 1.90	81 2.05	87 2.20	93 2.16	99 2.31	105 2.66
30 0.76							43 1.09	49 1.24	55 1.39	61 1.55	67 1.70	73 1.85	79 2.00	85 2.16	91 2.31	97 2.46	103 2.61
33 0.84								47 1.20	53 1.35	59 1.50	65 1.66	71 1.81	77 1.96	83 2.11	89 2.27	95 2.42	101 2.57
36 0.91									51 1.31	57 1.46	63 1.61	69 1.76	75 1.92	81 2.07	87 2.22	93 2.37	99 2.53
39 0.99										56 1.42	62 1.57	68 1.72	74 1.87	80 2.03	86 2.18	92 2.33	98 2.48
42 1.07											60 1.53	66 1.68	72 1.83	78 1.98	84 2.14	90 2.29	96 2.44
45 1.14												64 1.63	70 1.79	76 1.94	82 2.09	88 2.24	94 2.40
48 1.22													69 1.74	75 1.90	81 2.05	87 2.20	93 2.35

Note: Values shown are typical and will vary with weight of concrete and field conditions.

unit. An example contraction factor calculation is given on page 36 of this manual.

Layout drawings showing the field assembly of the fabric form armor units for the entire project are prepared. The drawings identify each armor unit, its location and sequence of installation, pertinent elevations and coordinates, direction of flow, anticipated water levels, and structures such as roads, curbs, bridges, intake and discharge pipes, culverts, ramps and other existing and future structures that may effect the placement of the fabric-forme d armor units.

Labeling:

The fabric forms should be labeled as per ASTM D 4873, "Guide for Identifying, Storage and Handling of Geosynthetics Rolls".

A submittal package which includes shop and layout drawings, a list of numbered fabric forms, form dimensions and areas, and a manufacturer's certification is assembled and forwarded to the contractor for submittal to the project engineer. Upon the project engineer's approval of the submittal package, Geostar's manufacturing department commences fabric form fabrication and confirms the delivery schedule.

Table 13.0 - Unfilled Fabric Form Width to Filled Volume of Armor Unit																	
Filled Thickness	Width of Unfilled Fabric Forms																
inches	24	30	36	42	48	54	60	66	72	78	84	90	96	102	108	114	120
meters	0.61	0.76	0.91	1.07	1.22	1.37	1.52	1.68	1.83	1.96	2.13	2.29	2.44	2.59	2.74	2.90	3.05
	Volume of Concrete - Cubic Feet per Foot of Length (Cubic Meter per Meter of Length)																
6 0.15	0.8 0.07	1.1 0.10	1.3 0.12	1.6 0.15	1.8 0.17	2.1 0.20	2.3 0.21	2.6 0.24	2.8 0.26	3.1 0.29	3.3 0.31	3.6 0.34	3.8 0.35	4.1 0.38	4.3 0.40	4.4 0.41	4.7 0.44
9 0.23	1.1 0.10	1.4 0.13	1.8 0.17	2.2 0.20	2.6 0.24	2.9 0.27	3.3 0.31	3.7 0.34	4.1 0.38	4.4 0.41	4.8 0.45	5.2 0.48	5.6 0.52	5.9 0.55	6.3 0.59	6.7 0.62	7.1 0.66
12 0.30	1.2 0.11	1.7 0.16	2.2 0.20	2.7 0.25	3.2 0.30	3.7 0.34	4.2 0.39	4.7 0.44	5.2 0.48	5.7 0.53	6.5 0.60	6.7 0.62	7.2 0.67	7.7 0.72	8.2 0.76	8.7 0.81	9.2 0.86
15 0.38		1.9 0.18	2.5 0.23	3.1 0.29	3.8 0.35	4.4 0.41	5.0 0.47	5.6 0.52	6.3 0.59	6.9 0.64	7.5 0.70	8.1 0.75	8.8 0.82	9.4 0.87	10.0 0.93	10.6 0.99	11.3 1.05
18 0.46			2.7 0.25	3.5 0.33	4.2 0.39	5.0 0.47	5.7 0.53	6.5 0.60	7.2 0.67	8.0 0.74	8.7 0.81	9.5 0.88	10.2 0.95	11.0 1.02	11.7 1.09	12.5 1.16	13.2 1.23
21 0.53				3.7 0.34	4.6 0.43	5.5 0.51	6.3 0.59	7.2 0.67	8.1 0.75	9.0 0.84	9.8 0.91	10.7 0.99	11.6 1.08	12.5 1.16	13.3 1.24	14.2 1.32	15.1 1.40
24 0.61					4.9 0.46	5.9 0.55	6.9 0.64	7.9 0.73	8.9 0.83	9.9 0.92	10.9 1.01	11.9 1.11	12.9 1.20	13.9 1.29	14.9 1.39	15.9 1.47	16.9 1.57
27 0.69						6.2 0.58	7.3 0.68	8.4 0.78	9.5 0.88	10.7 0.99	11.8 1.10	12.9 1.20	14.0 1.30	15.2 1.41	16.3 1.52	17.4 1.62	18.5 1.72
30 0.76							7.6 0.71	8.8 0.82	10.1 0.94	11.3 1.05	12.6 1.17	13.8 1.28	15.1 1.40	16.3 1.52	17.6 1.64	18.8 1.75	20.1 1.87
33 0.84								9.2 0.86	10.6 0.99	11.9 1.11	13.3 1.24	14.7 1.37	16.1 1.50	17.4 1.62	18.8 1.75	20.2 1.88	21.6 2.00
36 0.91									10.9 1.02	12.4 1.15	13.9 1.29	15.4 1.43	16.9 1.57	18.4 1.71	19.9 1.85	21.4 1.99	22.9 2.13
39 0.99										12.8 1.19	14.5 1.35	16.1 1.50	17.7 1.65	19.3 1.79	21.0 1.95	22.6 2.10	24.2 2.25
42 1.07											14.9 1.39	16.6 1.54	18.4 1.71	20.1 1.87	21.9 2.04	23.6 2.20	25.4 2.36
45 1.14												17.1 1.59	19.0 1.77	20.8 1.93	22.7 2.11	24.6 2.28	26.5 2.46
48 1.22													19.4 1.80	21.4 1.99	23.4 2.18	25.4 2.36	27.4 2.55

Note: Values shown are typical and will vary with weight of concrete and field conditions.

Proper Storage and Handling of Fabric Forms

Fabric forms are delivered at the job site in trailers or ocean containers. Fabric forms are stacked in a manner that assures ease of unloading. Standard 40 ft (12 m) long trailers or containers hold up to 215,000 ft² (20,000 m²) of fabric forms per load.

Armor unit fabric forms are normally shipped boxed. Alternatively they may each be wrapped in two layers of protective cover. The first layer (inner layer) is a waterproof, opaque, plastic cover the second (outer layer) is a woven, abrasion resistant, fabric cover.

When fabric forms are to be inventoried at the job site, they should be kept dry and remain boxed so that they are protected from the elements during storage and handling. If stored outdoors, they should be elevated and protected with a waterproof cover that is opaque to ultraviolet light. Care should be taken not to damage the fabric forms during unloading, storage and handling. *The contractor should unload the fabric forms by hand or with a forklift or similar equipment. When lifting fabric forms make sure that workers have proper back support.*

Contraction of HYDROCAST Armor Units

The definition drawing, Figure 61, illustrates the change in width that occurs when a fabric form is filled with concrete to form an armor unit. Table 12.0 is a guide in determining the required dimensions of an unfilled fabric form for casting a given concrete armor unit size. Table 13.0 is a guide in determining the volume of concrete required to fill a fabric form of given dimensions. The dimensions and volumes are calculated from dimensional equation and may not reflect field conditions.

Equations for determining the filled width and length of HYDROCAST Fabric Forms:

$$W = W_f + 0.57T$$

$$L = L_f + 0.57T$$

Where:

W = Width of unfilled fabric form

W_f = Width of filled fabric form

L = Length of unfilled fabric form

L_f = Length of filled fabric form

T = Thickness of filled fabric form

Equations for determining the volume of concrete required for filling HYDROCAST Fabric Forms:

$$V_f = 0.785 T^2 + T (W_f - T)$$

$$V_t = (V_f)(L_f)$$

Where:

V_f = Volume of concrete per unit length of filled armor unit

V_t = Total Volume of the filled armor unit

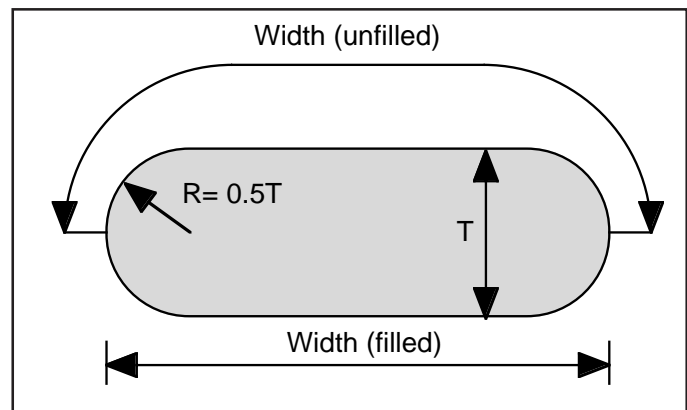

Figure 61

Example Calculation:

Determine the unfilled dimensions and filled volume for a 10 ft (3 m) long by 62 inches (1.57 m) wide by 18 inches (0.46 m) thick armor unit.

From equations:

$$W = W_f + 0.57T = 62 \text{ in} + 0.57 \times 18 \text{ in} = 72 \text{ in} (1.83 \text{ m})$$

$$L = L_f + 0.57T = 10 \text{ in} \times 12 \text{ in/ft} + 0.57 \times 18 \text{ in} = 130 \text{ in or } 11 \text{ ft}$$

$$V = V_f L_f = 7.3 \text{ ft}^2 \times 10 \text{ ft} = 73 \text{ ft}^3 \text{ or } 2.7 \text{ yd}^3 (2.1 \text{ m}^3)$$

From tables:

From Table 12.0 - For a filled width of 62 in (1.57 m), with a thickness of 18 in (0.46 m) and a length of 10 ft (3 m), a fabric form 11 ft long by 72 in wide would be selected.

From Table 13.0 - The volume of a 62 in (1.57 m) wide, by 18 in (0.46 m) thick and 10 ft (3 m) long fabric form would be approximately 72 ft³ or 2.7 yd³.

Note: The concrete-filled thickness of the fabric form should be not more than 70 percent of the width of the unfilled fabric form.

Installation of HYDROCAST Armor Units

Equipment and Tools

Because of the simple installation procedure for HYDROCAST Armor Units, a nominal amount of tools and equipment are required. We suggest that the contractor have on hand the following:

Tools:

Surveyor's level and rod	Shovels
Rakes	Hammers
Stakes	String line
Rubber boots and gloves	Pail
Safety glasses or goggles	Scissors
Trowels	

Equipment:

- Small line concrete pump
- Concrete pump hose - 2 inch (50 mm) diameter
- Injection pipe - 2 inch (50 mm) diameter
- Hand-held sewing machine (electric or air powered) with speed control
- Extension cord (if electrical equipment is used)
- Electric generator with ground fault circuit breaker
- Air compressor (for air powered sewing machine)
- Small, walk-behind flat or vibratory compactor for soil compaction

A list of equipment manufacturers is provided in the appendices. However, Geostar Corporation makes no warranty nor guarantees the performance of equipment provided by another manufacturer.

Sequence of Armor Unit Installation

Once the area to be protected has been excavated, graded and compacted to the lines and grades specified in the Contract Drawings and Specifications, an installation crew, filter fabric (if required), fabric forms, and the tools and equipment listed above should be mobilized to the job site. *Freshly excavated and graded slopes are highly subject to erosion and should be protected from water runoff, flowing water and waves.*

Depending on the location of the area, dimensions, and the rate of subgrade preparation, installation rates of as much as 15 yd³ (11.5 m³) of fine aggregate concrete per hour can be achieved by a crew of 3 or 4 laborers, a concrete pump operator and a supervisor.

Establish the starting point.

The first step in the installation of fabric-formed concrete armor units is to establish a starting point. If a working point and direction of placement are shown on the Contract Drawings this should be the starting point. If this is not the case, it is the customary practice for channels, streams and rivers to work from the upstream end of the project to the downstream end. In this manner the flow of the water will tend to spread

the fabric forms out ahead of the finished work and the finished concrete armor unit is protected from undercutting. For inland and coastal shorelines it is customary practice to install the first course of armor units then proceed to succeeding courses. *Fabric form armor unit layout drawings, available from Geostar Corporation, will recommend starting points and directions of placement for the project.*

Establish the alignment lines

Once a starting point has been established a surveyor's level should be used to determine the longitudinal and slope alignment lines of the fabric-formed concrete armor units. String lines should then be placed along the respective alignment lines and staked. Generally, the alignment lines are offset, by a measured distance, to the opposite side of any trench or a minimum of 5 feet (1.5 m) in order not to interfere with the work area. *The method of establishing reference points and lines should be left to the discretion of the contractor.*

Placement of the filter fabric, if required

Under certain soil conditions or if called for in the Contract Drawings and Specifications, it will be necessary to place filter fabric and/or a granular sublayer under the fabric forms to guarantee that soil is not piped through any spaces between the armor units. Filter fabric should be selected and placed in accordance with the Contract Drawings and Specifications or in the absence of such directions in accordance with the manufacturer's guidelines. *Filter fabrics and their installation are discussed, in brief, earlier in this manual (page 7).*

Placement of the first course of armor unit fabric forms

The prefabricated armor unit forms are folded and marked with the appropriate form numbers and dimensions at the factory for easy identification, location and installation.

The first armor unit fabric form, in the first course, should be carefully placed at the designated starting point and unfolded into position (Fig 62). Special care should be taken to assure that the sides and ends of the form are exactly parallel to their respective alignment lines.

Armor unit fabric forms should be placed loosely, but without folds, to allow for proper filling with fine aggregate concrete. The extra fabric provided for form contraction should be extended. Forms that are stretched or taut will not permit the required form contraction, therefore the fabric forms will not fill to their required thicknesses. For example, a 72 inch by 120 inch (183 cm x 305 cm) form is to be filled to a thickness of 30 inches (76 cm). When filled with fine aggregate concrete to this thickness, the width and length of the form will contract by approximately 57% of the thickness, giving a finished armor unit dimension of 55 inches x 103 inches (139 cm x 261 cm). Adjacent armor units (of the same dimensions

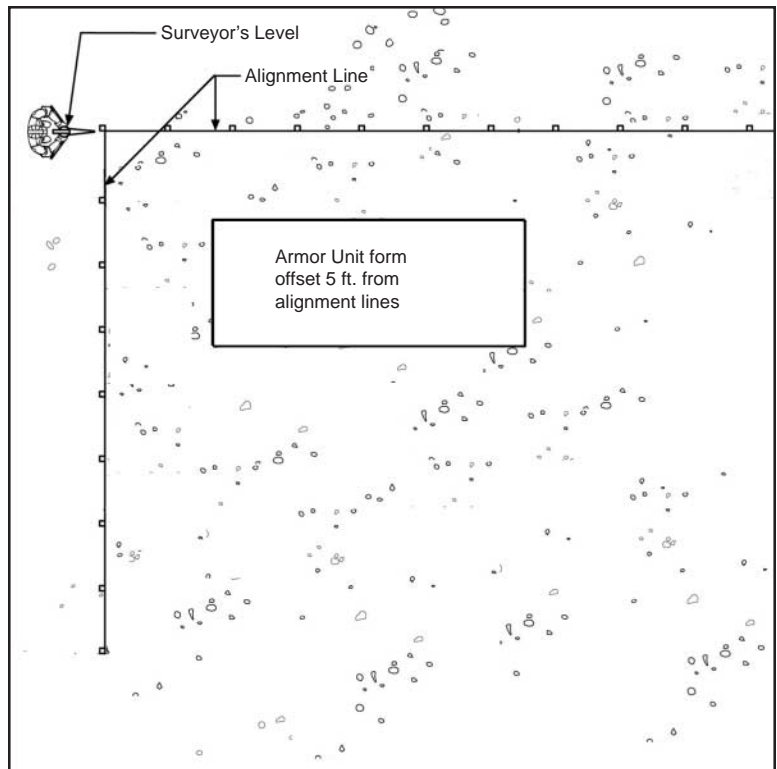

Figure 62

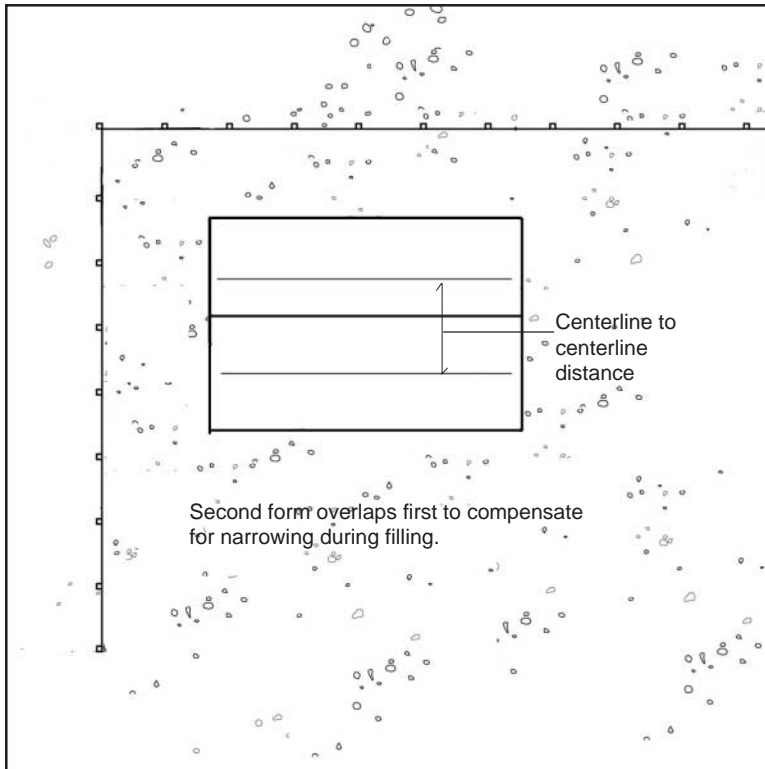

Figure 63

used in this example) should therefore be placed with their centers 17 inches (43 cm) closer together than called for by the unfilled form dimensions.

The second armor unit form in the first course should be placed alongside the first form so that the centerline to centerline distance equals that of the calculated armor unit width after contraction, as shown in Figure 63. After the second armor unit form has been positioned, the alignment of the forms should be checked.

The remaining armor unit forms in the first course should be placed side-by-side in the same manner. The alignment of the forms should be checked periodically since small errors in alignment can progress in severity. Armor unit form alignment is important in providing a uniform and attractive appearance in the finished installation.

Armor unit form placement should precede concrete filling by no more than the distance that can be completed in one day. Where the forms may be exposed to flowing water or wave action, each form should be filled with fine aggregate concrete prior to placement of the adjacent form.

Placement of the second course of armor unit fabric forms

The second course of armor unit forms should be placed atop the fine aggregate concrete filled first course. (See Sequence of Fine Aggregate Concrete Pumping.) The center line of the first form in the second course is positioned directly over the abutting edges of the first two armor units in the first course, as shown in Figure 64. The staggering of the centerlines of the armor units in vertically adjacent courses encourages “nesting” of armor units and facilitates alignment. The remaining forms in the second course should be placed side-by-side in the same manner as the first course. Once again, check alignment periodically since small errors can progress in severity.

When constructing structures subject to wave action, the armor units should be aligned with their long axis facing the principal direction of wave attack.

Underwater placement of fabric-formed armor units may require the use of divers. The divers can prepare the finished grading, inspect the area to be protected, and position and secure the filter fabric and fabric forms. The securing of the forms may require sand bags or weights.

A small quantity of bulk (uncut and unassembled) form fabric should be ordered for each project. The fabric can be used for special field tailoring. At least one half a roll, about 900 ft² (84 m²) of bulk fabric, is recommended.

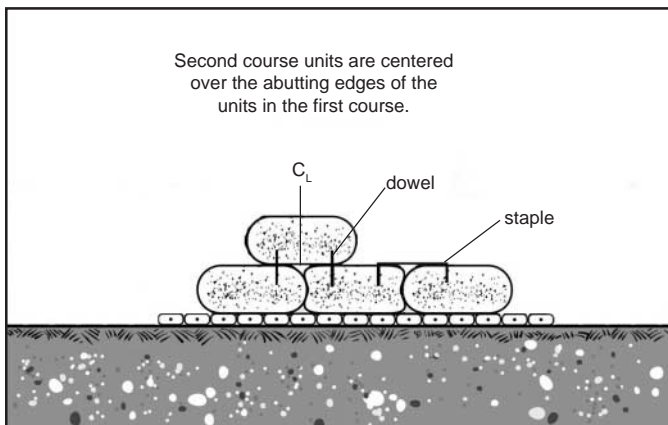

Figure 64

Sequence of Fine Aggregate Concrete Pumping

Ordering fine aggregate concrete

Fine aggregate concrete is generally delivered to the job site in ready-mix trucks. The order for concrete should be placed a least one day prior to its scheduled delivery to the job site. The concrete supplier should be instructed to fill the water tank of each truck with mix water. *It is common that the first few loads delivered to the job site will not be fluid enough for pumping and will require the addition of mix water.* In order to avoid presetting of the fine aggregate concrete it is recommended that the concrete be delivered in loads of no more than 8 yd³ (6 m³). At a minimum, the first load of each day should be checked with a standard flow cone for consistency, in accordance with ASTM D 6449. *The addition of pea gravel to the mix may reduce the cost of materials with a slight increase in labor costs. When pumping concrete with pea gravel, the diameter of the pump hose should be increased.*

Securing the armor unit forms

Beginning at the designated starting point the installation crew should check and adjust the armor unit forms to assure that they are in alignment. After the forms have been properly adjusted, fine aggregate concrete is pumped into forms. *It must be emphasized that care should be exercised in the alignment and securing of the first course of armor units. This will ensure the aesthetics of the concrete armor units and also hasten the installation of subsequent courses.*

Inserting the fine aggregate concrete injection pipe

Fine aggregate concrete should be pumped into the fabric form armor unit by inserting the injection pipe through a self-closing "pocket type" filling valve in the upper layer of the fabric. A tight seal is made when the injection pipe is inserted into the valve. When the pipe is withdrawn, the valve shuts.

Filling the first fabric form armor unit with fine aggregate concrete

Starting at the first fabric form armor unit, the injection pipe should be inserted into the self closing filling valve. The form should be filled by pumping fine aggregate concrete into the form. The fine aggregate concrete should fill the center and corners of the form, proceeding gradually to the specified thickness. *Pressure from the concrete fill helps close the filling valve.*

The injection pipe should then be moved to the adjacent armor unit form and inserted into the filling valve. Once again, the previous pumping procedure should be repeated until this form has been filled to its specified thickness.

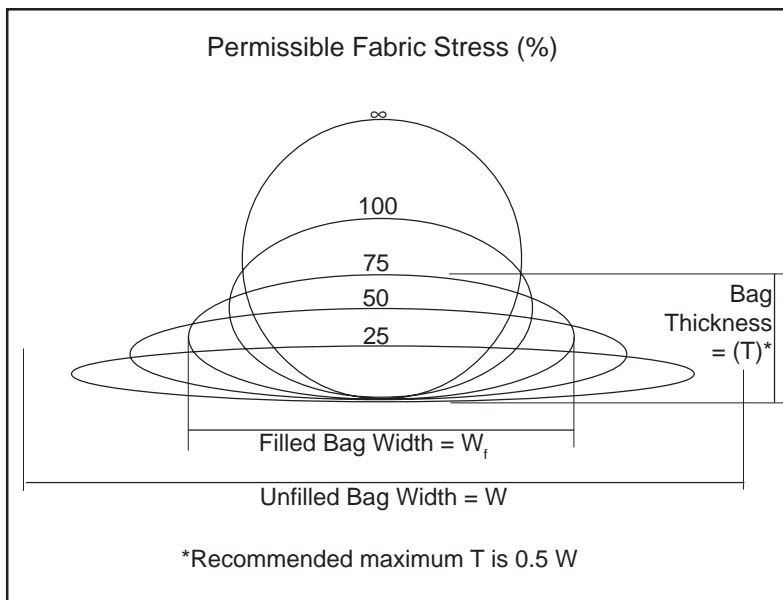

Figure 65

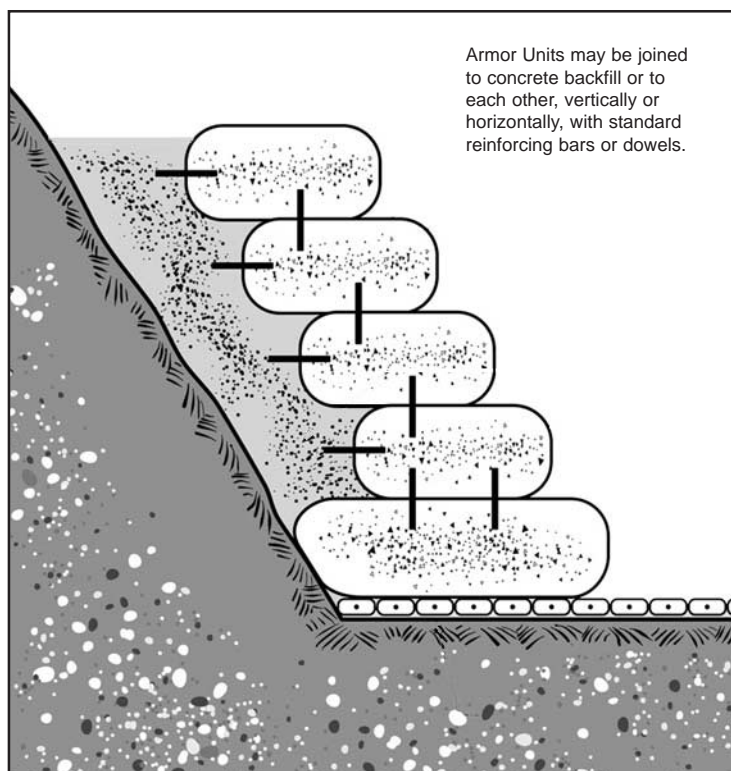

Figure 66

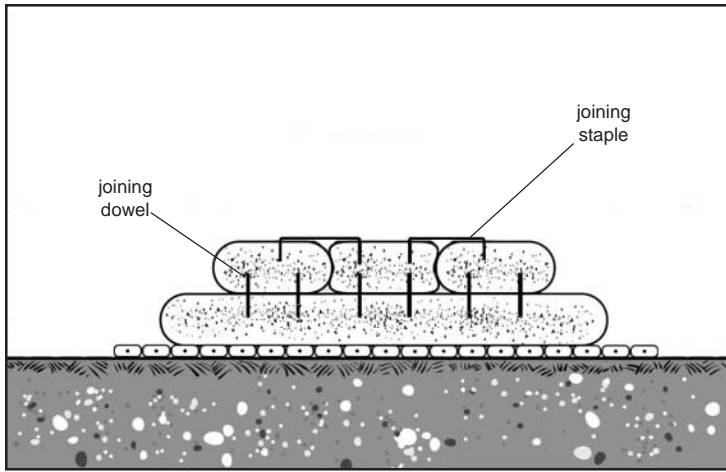

Figure 67- Typical cross section

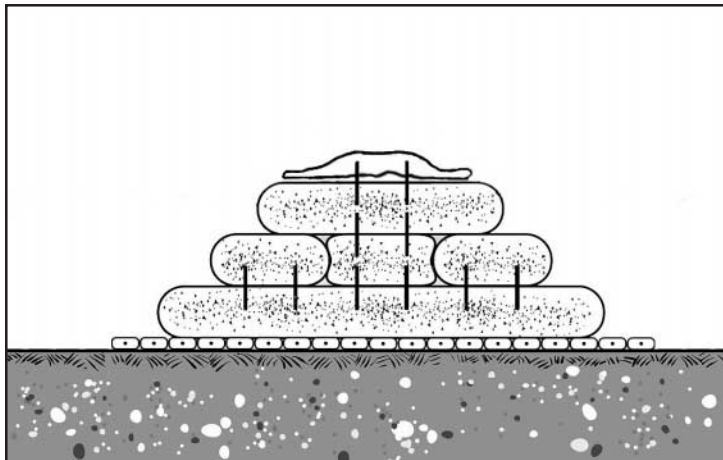

Figure 68- Armor Unit form ready for filling

Overpressuring of fabric forms

Care must be taken when pumping fabric forms to assure that the fabric is not over pressurized. Over pressurization may cause bursting of seams. Please refer to Table 12.0 for recommended filling thicknesses per width. See also Figure 65 for fabric stress at differing fill geometries.

Connecting fine aggregate concrete armor units

Armor units are easily joined by inserting steel reinforcement bars, “dowels” or “staples” as suggested in Figures 66 and 67. When connecting vertically adjacent courses of armor units by inserting dowels, first force the pointed ends of the reinforcement bars through the fabric and into the fresh concrete of the filled armor units. Dowels or staples shall be inserted into the filled unit(s) not less than one half hour and not more than one hour after filling of the unit, unless directed otherwise by the Engineer. The forms in the succeeding course are then threaded over the exposed reinforcement bar ends. The dowels are then forced through the bottom layer of the vertically adjacent fabric form (Fig. 68), and the form is then filled with fine aggregate concrete.

Armor units may be connected side-by-side by inserting staples; bend the reinforcement bars into an elongated “U” shape and force the pointed ends of the reinforcement bars through the fabric and into the fresh concrete of the filled armor units. The dowels and staples assist in holding the forms in place during filling and maintaining the alignment of the armor unit structure. Abutting armor units, if placed laterally, may be installed immediately after placement of the preceding unit(s). If an armor unit is to bear on previously installed units, the lower units must be allotted a minimum of four hours of cure time before beginning installation of a succeeding, vertically adjacent course of armor units.

Where required, reinforcement bar cages are installed in the forms through openings in the forms. The form opening is closed before filling by means of a zipper or a portable sewing machine. Reinforcement bar cages are suspended by tie wires from the upper side of the form to assure centering.

Circumferential straps may be attached to armor unit forms as thickness indicators to facilitate the filling of forms underwater. Slight depressions formed by the straps in the surface of the armor unit indicate to the diver, working by touch, that the form has been filled to the specified thickness.

Circumferential straps of predetermined circumferences and spacing, with or without external restraining reinforcement bars, permit the casting of tapering or irregularly shaped armor units.

Filling remaining fabric form armor units with fine aggregate concrete

If care has been taken in positioning the forms and in concrete filling the first course of armor unit forms, little, if any, adjustment of subsequent courses should be required. However, form alignment should be checked periodically since small errors in alignment can progress in severity. Periodically check the location of the forms with an instrument to assure that proper alignment is being maintained.

Special Considerations

Pipes, piles, culverts, trees, and other appurtenances

Armor unit forms should be tailored in the field to fit around pipes, culverts, trees, and other appurtenances. A form may be field cut and sewn or bulk fabric may be fabricated to fit snugly around the object.

Backfilling and compaction of trenches

The backfilling and compaction of open excavations should not begin until at least one hour after filling the adjacent concrete armor unit. Backfill material may be either select bedding materials or fine aggregate concrete. The excavations should be backfilled as shown on the Contract Drawings. *The open excavations behind completed sections of armor units should be backfilled and compacted by the end of the work day.*

Foot traffic

Foot traffic on the freshly pumped fine aggregate concrete armor unit should be avoided for a period of not less than one hour after concrete injection or until the concrete is resistant to indentation. Should traffic be unavoidable, the contractor should place board walks along the finished filled concrete areas. This will reduce the amount of objectionable indentation. *Footprints will leave permanent impressions in the installed fabric-formed concrete armor units.*

Cleanup

Any fine aggregate concrete that may spill on top of the fabric-formed concrete armor unit should be picked up by hand or trowel and the surface smoothed by cloth or broom. Such unnecessary spillage of concrete will cause an unsightly appearance. This is particularly important along the top of the final course of armor units.

The installation crew should be instructed to carefully "kink" the concrete pump hose when it is moved from one injection point to another or to place the end of the concrete injection pipe in a pail when moving the concrete pump hose.

The freshly pumped fabric-formed concrete units should never be washed (sprayed) under pressure with water in an effort to clean or remove spills from its surface. A wet cloth should be used for clean up and spill removal.

The cement film that impregnates the fabric forms provides a bond between the fabric form and the concrete fill and a degree of protection against ultraviolet degradation of the fabric. Should this film be removed by washing the uncured concrete armor units, cement may be also washed out from beneath the layer of fabric. The result would be a loss of concrete-to-fabric bond, a sandy, low strength outer surface of concrete and a concrete armor units which will exhibit low abrasion resistance and durability.

APPENDIX 1 - CONCRETE PUMPING EQUIPMENT MANUFACTURERS

Manufacturer	Mayco Pump A Multiquip Company P.O. Box 6254 Carson, CA 90749 USA Tel: 310/537-3700 800/537-3927 Fax: 310/537-3927	Olin Engineering 15592 Computer Lane Huntingdon Beach, CA 92649 USA Tel: 714/897-1230 Fax: 714/892-9268	Schwing America, Inc Small Line Division 5900 Centerville Road St. Paul, MN 55127 USA Tel: 612/429-8651 Fax: 612/429-8616
Model	C - 30HD	525	P - 88
Performance			
Concrete Output	25 yd ³ /hr (19 m ³ /hr)	32 yd ³ /hr (24 m ³ /hr)	25 yd ³ /hr (19 m ³ /hr)
Concrete Pressure	-	750 psi (53 Bar.)	500 psi (35 Bar.)
Horizontal Pumping Distance	500 ft (150 m)	800 ft (244 m)	500 ft (150 m)
Maximum Aggregate Size	0.5 in (13 mm)	0.5 in (13 mm)	0.5 in (13 mm)
Pump			
Volume Control	Variable - Adjustable stroke and speed	Variable - Adjustable stroke and speed	Variable - Adjustable stroke and speed
Concrete Cylinder Diameter	6 in (150 mm)	5 in (127 mm)	6 in (150 mm)
Concrete Cylinder Stroke	-	12 in (305 mm)	7.75, 6.5, 5.375, or 4.625 in (197, 165, 143, or 118 mm)
Valve Type	Ball valve	Ball valve	Ball valve
Hopper Capacity	6 ft ³ (0.17m ³)	5 ft ³ (0.14m ³)	6 ft ³ (0.17m ³)
Maximum Line Size	2 in (50mm), 2.5 in (62 mm)	4 in (100mm)	3 in (75 mm)
Remote Control	Standard	Standard	Standard
	Optional - Radio (Wireless)	Optional - Radio (Wireless)	Optional - Radio (Wireless)
Surge Chamber	-	Standard	-
Engines			
Standard Engine	30 hp (23 kW) Wisconsin Gas	41hp (30kW) Deutz Diesel	30 hp (23 kW) Wisconsin Gas
Optional Engines	30hp (23 kW) Hatz Diesel		20hp (15 kW) Electric 33hp (25 kW) Hatz Diesel
Weight	2200 lbs (999 kg)	3000 lbs (1360 kg)	2360 lbs (1071 kg)
Manufacturer	Reed Concrete Placing Equipment 13822 Oaks Ave. Chino, CA 91708 USA Tel: 909/364-2100 Fax: 909/364-2140	Reinert Manufacturing Co. 7968 Kentucky Drive, Ste. 1 Florence, KY 41042 USA Tel: 606/525-8488 Fax: 606/525-2484	Thomsen Machinery, Inc. 101 South Main Street Gardena, CA 90248 USA Tel: 310/769-4500 Fax: 310/516-9820
Model	B 30	ZR - 424	Putzmeister P 30G
Performance			
Concrete Output	30 yd ³ /hr (23m ³ /hr)	20yd ³ /hr (15m ³ /hr)	25 yd ³ /hr (19 m ³ /hr)
Concrete Pressure	1026 psi (70 Bar.)	625 psi (44 Bar.)	425 psi (29 Bar.)
Horizontal Pumping Distance	-	400 ft (120 m)	400 ft (120 m)
Maximum Aggregate Size	1.5 in (38 mm)	1 in (25 mm)	0.5 in (13 mm)
Pump			
Volume Control	Variable - Adjustable stroke and speed	Variable - Adjustable stroke and speed	Variable - Adjustable stroke and speed
Concrete Cylinder Diameter	6 in (150 mm)	4 in (100 mm)	6 in (150 mm)
Concrete Cylinder Stroke	-	24 in (609 mm)	12 in (305 mm)
Valve Type	S valve	S valve	Ball
Hopper Capacity	10 ft ³ (0.28 m ³)	8 ft ³ (0.23 m ³)	6 ft ³ (0.17m ³)
Maximum Line Size	5 in (125 mm)	3 in (75 mm)	-
Remote Control	-	-	Yes
Surge Chamber	-	-	-
Engines			
Standard Engine	54 hp (40 kW)Deutz Diesel	30 hp (23 kW) Wisconsin Gas	30 hp (23 kW) Wisconsin Gas
Optional Engines			37 hp (27 kW) Hatz Diesel 20hp (15 kW) Electric
Weight	4450 lbs (2019 kg)	2000 lbs (978 kg)	2400 lbs (1090 kg)

APPENDIX 2 - HAND-HELD SEWING MACHINES

Manufacturer	Fischbein Company 151 Walker Road Statesville, N.C. 28625	American-Newlong, Inc. 5310 South Harding Street Indianapolis, IN 46217	Union Special Corporation One Union Special Plaza Huntley, IL 60142
	Tel: 704/871-1159 Fax: 704/872-3303	Tel: 317/787-9421 Fax: 317/786-5225	Tel: 800/344-9698 Fax: 708/669-5804

Model	ECR	NP-7A	2200
Performance			
Stitches per Minute	-	1500-1600	1200-1700
Stitch	Single thread, 101 stitch	Single thread, 101 stitch	Two thread, single needle, 401 stitch or Single thread, 101 stitch
Stitch Length	-	Fixed 3 SPI (8.5 mm)	Adjustable 3-8.5 SPI
Needle	-	DNx1-#25	-
Drive Motors			
AC	115 V, 1.1 amps 220 V, 0.6 amps	60W 50/60Hz, 1-ph., 12V, 24V, 110V, 220V, or 240V	Electric or Pneumatic
DC	12V, 9 amps	12 V	
Pneumatic	Yes	-	-
Weight	11 lbs (5 kg)	12 lbs (5.3 kg)	11 lbs (5.0 kg)

Hydrotex and Hydrocast products are manufactured by:

Geostar Corporation

53 Perimeter Center East, Suite 250

Atlanta, Georgia 30346 (USA)

Tel: 1.800.253.0561 or 770.399.5051 Fax: 770.394.5999

<http://www.geostarcorporation.com> • e-mail: info@geostarcorporation.com

Hydrotex, Hydrocast, Filter Band, and Enviromat are trademarks of Geostar Corporation.

© 2001, Geostar Corporation Printed in U.S.A.

The information contained herein was derived based on the use of products manufactured by Geostar Corporation. Their use or application with the products of another manufacturer is not recommended, due to differences in material composition or differences in manufacturing technique, and may produce unintentioned results. This information is intended for the use of the entity or individual to whom it is addressed and may contain information that is privileged, confidential and exempt for disclosure under applicable law.

The information contained herein is furnished without charge or obligation, and the recipient assumes all responsibility for its use. Because conditions of use and handling may vary and are beyond our control, we make no representation about, and are not responsible for, the accuracy or reliability of said information or the performance of any product. Any specifications, properties or applications listed are provided as information only and in no way modify, enlarge or create any warranty. Nothing contained herein is to be construed as permission or as a recommendation to infringe any patent.

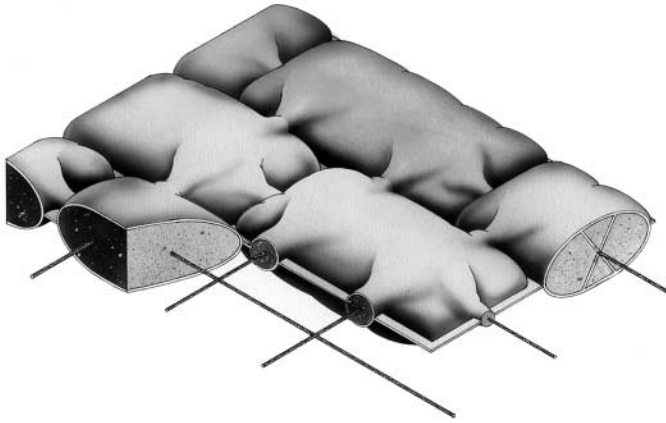

HYDROTEX™

Specification Guideline Fabric-formed Concrete Erosion Control Systems

Articulating Block Mat

Table 1.0 Typical Dimensions and Weights

Articulating Block	AB400	AB600	AB800	AB1000	AB1200
Average Thickness, in (mm)	4.0 (102)	6.0 (152)	8.0 (203)	10 (254)	12 (305)
Mass Per Unit Area, lb/ft ² (kg/m ²)	45 (220)	68 (330)	90 (440)	113 (550)	135 (661)
Mass per Block, lb (kg)	88 (39.8)	188 (85.2)	325 (148)	563 (255)	844 (382)
Nominal Block Dimensions, in (mm)	20 x 14 (508 x 356)	20 x 20 (508 x 508)	20 x 26 (508 x 660)	30 x 24 (762 x 610)	30 x 30 (762 x 762)
Concrete Coverage, ft ² /yd ³ (m ² /m ³)	75 (9.1)	50 (6.1)	38 (4.6)	30 (3.6)	25 (3.0)
Shear Resistance, lb/ft ² (kg/m ²)	26 (127)	39 (190)	52 (254)	65 (317)	78 (381)

Note: Values shown are typical and will vary with weight of concrete and field conditions.

Product Description

Articulating Block Mats form cable-reinforced concrete block mattresses that resist erosive forces. They are often constructed where a revetment is exposed to frontal attack by wave action. AB Mats are typically used to protect coastlines, underwater pipelines, bridge piers, and other marine structures from propeller wash, ship wakes, wind waves, currents, and high velocity flows. They are also used in environmental construction for landfill caps, down chutes, and collector channels.

The AB fabric form consists of a series of compartments, linked by an interwoven perimeter. Ducts interconnect the compartments, and high strength revetment cables are installed between and through the compartments and ducts. Once filled, the AB Mats becomes a mattress of pillow-shaped, rectangular concrete blocks. The interwoven perimeters between the blocks serves as a hinge to permit articulation. The cables remain embedded in the concrete blocks to link the blocks together and facilitate articulation.

Relief of hydrostatic pressure, when required, is accomplished through slits cut between blocks and/or by inserting plastic weep tubes at specified centers prior to filling the form with concrete.

1.0 GENERAL

1.1 Scope of Work: The Contractor shall furnish all labor, materials, equipment, and incidentals required to perform all operations in connection with the installation of the proposed Articulating Block (AB) Lining in accordance with the lines, grades, design, and dimensions shown on the Contract Drawings and as specified herein.

1.2 Description: The work shall consist of installing an unreinforced concrete lining by positioning specially woven, double-layer synthetic forms on the surface to be protected and filling them with a pumpable, fine aggregate concrete (structural grout) in such a way as to form a stable lining of required thickness, weight and configuration.

2.0 MATERIALS REQUIREMENTS

2.1 Fine Aggregate Concrete: Fine aggregate concrete shall consist of a proportioned mixture of Portland cement, fine aggregate (sand) and water. The consistency of the fine aggregate concrete delivered to the concrete pump shall be proportioned and mixed as to have an efflux time of 9-12 seconds when passed through the 0.75 inch (19 mm) orifice of the standard flow cone that is described in ASTM C 939. Pozzolan, fluidifier or pumping aid conforming to this Specification may be used at the option of the Contractor. The mix shall exhibit a compressive strength of 2,000 lb/in² (13.8 MPa) at 28 days, when made and tested in accordance with ASTM C 31 and C 39.

2.1.1 Portland cement shall conform to ASTM C 150, Type I or Type II.

2.1.2 Fine aggregate shall conform to ASTM C 33, except as to grading. Aggregate grading shall be reasonably consistent and shall not exceed the maximum size which can be conveniently handled with available pumping equipment.

2.1.3 Water for mixing shall be clean and free from injurious amounts of oil, acid, salt, alkali, organic matter or other deleterious substances.

PROPERTY REQUIREMENTS - ARTICULATING BLOCK FABRIC^{1, 2}

Property	Test Method	Units	Values
Physical:			
Composition of Yarns			Nylon or polyester
Mass Per Unit Area (double-layer)	ASTM D 5261	oz/yd ² (g/m ²)	12 (403)
Thickness	ASTM D 5199	mils (mm)	25 (0.6)
Mill Width		in (m)	76 (1.92)
Mechanical:			
Wide-Width Strip Tensile Strength	- Machine	ASTM D 4595	lbf/in (kN/m)
	- Cross		lbf/in (kN/m)
Elongation at Break	- Machine	ASTM D 4595	%
	- Cross		%
Trapezoidal Tear Strength	- Machine	ASTM D 4533	lbf (N)
	- Cross		lbf (N)
Hydraulic:			
Apparent Opening Size (AOS)	ASTM D 4751	U.S. Standard Sieve (mm)	40 (0.425)
Flow Rate	ASTM D 4491	gal/min/ft ² (l/min/m ²)	90 (3665)

Notes:

1. Conformance of fabric to specification property requirements shall be based on ASTM D 4759, "Practice for Determining the Specification Conformance of Geotextiles."
2. All numerical values represent minimum average roll values (i.e., average of test results from any sample roll in a lot shall meet or exceed the minimum values). Lots shall be sampled according to ASTM D 4354, "Practice for Sampling of Geosynthetics for Testing."

2.1.4 Pozzolan, if used, shall conform to ASTM C 618, Class C, F or N.

2.1.5 Plasticizing and air entraining admixtures, if used, shall conform to ASTM C 494 and ASTM C 260, respectively.

2.2 Fabric Forms: The fabric forms shall be as specified, HYDROTEX™ Articulating Block (see Note A) forms as manufactured by Geostar Corporation; 74 Perimeter Center East, Suite 7420; Atlanta, Georgia 30346-1803, Tel: 800.253.0561 (770.399.5051); or approved equal. The fabric forms shall be composed of synthetic yarns formed into a woven fabric. Yarns used in the manufacture of the fabric shall be composed of nylon and/or polyester. Forms shall be woven with a minimum of 50% textured yarns (by weight) to improve adhesion to fine aggregate concrete and to improve filtration. Partially-oriented (POY), draw-textured, and/or staple yarns shall not be used in the manufacture of the fabric. Each layer of fabric shall conform to the physical, mechanical and hydraulic requirements referenced herein. The fabric forms shall be free of defects or flaws which significantly affect their physical, mechanical, or hydraulic properties.

Note A: The engineer shall indicate the Articulating Block Mat size required (see Table 1.0). Example: AB400.

2.2.1 Fabric forms shall consist of double-layer woven fabric joined together by narrow perimeters of interwoven fabric into a matrix of rectangular compartments that form a concrete articulating block mat with finished nominal block dimensions of ___ inches (mm) x ___ inches (mm) (see Table 1.0), a finished average thickness of (see Table 1.0) inches (mm) and a nominal mass per unit area of (see Table 1.0) lb/ft² (kg/m²). Cords shall connect the two layers of fabric at the center of each compartment. The cords shall be interwoven in two sets of four cords each, one set for the upper layer and one set for the bottom layer. Each cord shall have a minimum breaking strength of 160 lbf (710 N) when tested in accordance with ASTM D 2256. Fabric form compartments shall be offset one half a com-

partment length, in the mill width direction, to form a bonded concrete block pattern.

2.2.2 Fabric form compartments shall each have six ducts, two on each of the long sides and one on each of the short sides to allow passage of the fine aggregate concrete between adjacent compartments. The fine aggregate concrete filled, cross-sectional area of each duct shall be no more than 10 percent of the maximum filled cross sectional area of the block transverse to the duct.

2.2.3 Mill widths of fabric shall be a minimum of 76 inches (1.92 m). Each selvage edge of the top and bottom layers of fabric shall be reinforced for a width of not less than 1.35 inches (35 mm) by adding a minimum of 6 warp yarns to each selvage construction. Mill width rolls shall be cut to the length required, and the double-layer fabric separately joined, bottom layer to bottom layer and top layer to top layer, by means of sewing thread, to form multiple mill width panels with sewn seams on not less than 72 inch (182 cm) centers.

2.2.4 All factory-sewn seams shall be downward facing as shown on the Contract Drawings. All seams sewn in the factory shall be not less than 90 lbf/in (15.7 kN/m) when tested in accordance with ASTM D 4884. All sewn seams and zipper attachments shall be made using a double line of U.S. Federal Standard Type 401 stitch. All stitches shall be sewn simultaneously and be parallel to each other, spaced between 0.25 inches (6 mm) to 0.75 inches (19 mm) apart. Each row of stitching shall consist of 4 to 7 stitches per inch (per 25.4 mm). Thread used for seaming shall be nylon and/or polyester.

2.2.5 Baffles shall be installed at predetermined mill width intervals to regulate the distance of lateral flow of fine aggregate concrete. The baffle material shall be nonwoven filter fabric. The grab tensile strength of the filter fabric shall be not less than 90 lbf/in (400 N) when tested in accordance with ASTM D 4632.

2.2.6 Fabric Form Shipment and Storage: The fabric forms shall be kept dry and wrapped such that they are protected from the elements during shipping and storage. If stored outdoors, they shall be elevated and protected with a waterproof cover that is opaque to ultraviolet light. The fabric forms shall be labeled as per ASTM D 4873, "Guide for Identification, Storage and Handling of Geosynthetic Rolls."

2.2.7 Cables shall be installed in the longitudinal direction between the two layers of fabric. A minimum of two longitudinal cables shall pass through each compartment in a manner which provides for the longitudinal and lateral binding of the finished articulating block mat. The cables shall enter and exit the compartments through opposing ducts. The longitudinal cables shall be on approximately 10 inch (25 cm) centers, when measured along the finished mat. All cables within each filled concrete block shall be completely embedded in the fine aggregate concrete.

2.2.8 Cables shall be constructed of high tenacity, low elongation, continuous filament polyester fibers. Cables shall be nominally ____ inches (mm) in diameter and their rated breaking strength shall be not less than ____ lbf (N).

2.2.9 Cable fittings shall be selected so that the resultant cable splice shall provide a minimum of 80 percent of the rated breaking strength of the cable. All cable splices shall have a minimum cable overlap of 6 inches (15.3 cm) and be made with aluminum compression fittings.

2.2.10 The Contractor shall submit a manufacturer's certificate that the supplied fabric forms meet the criteria of these Specifications, as measured in full accordance with the test methods and standards referenced herein. The certificates shall include the following information about each fabric form delivered:

- Manufacturer's name and current address;
- full product name;
- style and product code number;
- form number(s);
- composition of yarns; and
- manufacturer's certification statement.

2.3 Filter Fabrics: The filter fabrics shall be composed of synthetic fibers or yarns formed into a nonwoven or woven fabric. Fibers and yarns used in the manufacture of filter fabrics shall be composed of at least 85% by weight of polypropylene, polyester or polyethylene. They shall be formed into a network such that the filaments or yarns retain dimensional stability relative to each other, including selvages. These materials shall conform to the physical requirements shown below. The filter fabric shall be free of defects or flaws which significantly affect its mechanical or hydraulic properties.

PROPERTY REQUIREMENTS - FILTER FABRIC ^{1, 2}			
Property	Test Method	Units	Values
Grab Tensile Strength	ASTM D 4632	lbf (N)	90 (400)
Elongation at Break	ASTM D 4632	%	15
Trapezoidal Tear Strength	ASTM D 4533	lbf (N)	30 (130)
Permittivity	ASTM D 4491	sec ⁻¹	0.5

Notes:

1. Conformance of filter fabrics to specification property requirements shall be based on ASTM D 4759, "Practice for Determining the Specification Conformance of Geotextiles."
2. All numerical values represent minimum average roll values (i.e., average of test results from any sample roll in a lot shall meet or exceed the minimum values). Lots shall be sampled according to ASTM D 4354, "Practice for Sampling of Geosynthetics for Testing."

3.0 DESIGN REQUIREMENTS

Note B: Select the appropriate pair of paragraphs for the final specification based upon the type of hydraulic application.

The average thickness, mass per unit area and hydraulic resistance of each concrete lining shall withstand the hydraulic loadings (velocity, depth, duration, shear stress, pressure, and frequency of immersion) for the design discharges along the structure(s). The stability analysis for each concrete lining shall be accomplished using a factor-of-safety methodology. A minimum factor of safety of 1.5 shall be required.

The Contractor shall provide to the Engineer calculations and design details, provided by the manufacturer or a professional engineer, attesting to the suitability of each fabric formed concrete lining for the purpose contemplated. Each concrete lining shall be accepted only when accompanied by the documented hydraulic performance characteristics derived from tests performed under controlled flow conditions. Test conditions shall conform to test protocol as documented in "Hydraulic Stability of Fabric Formed Concrete Lining and Mat Systems During Over-topping Flow."

or

The average thickness, mass per unit area and hydraulic resistance of each concrete lining shall withstand the hydraulic loadings (depth, duration, type of wave, wave height and period, and pressure distribution) for the design wave. The stability analysis for the concrete lining shall be accomplished using the factor-of-safety methodology. A minimum factor of safety of 1.5 shall be required.

The Contractor shall provide to the Engineer calculations and design details, provided by the manufacturer or a professional engineer, attesting to the suitability of each fabric formed concrete lining for the purpose contemplated. Each concrete lining shall be accepted only when accompanied by hydraulic stability calculations derived from mathematical models developed specifically for fabric formed concrete linings and for this purpose.

4.0 CONSTRUCTION AND INSTALLATION REQUIREMENTS

4.1 Site Preparation

4.1.1 Areas on which fabric forms are to be placed shall be constructed to the lines, grades, contours, and dimensions shown on the Contract Drawings. All obstructions such as roots and projecting stones shall be removed. Where such areas are below the allowable grades, they shall be brought to grade by placing compacted layers of select material. The thickness of layers and the amount of compaction shall be as specified by the Engineer. Where required by the Contract Specifications, soft and otherwise unsuitable subgrade soils shall be identified, excavated and replaced with select materials in accordance with the Contract Specifications.

4.1.2 Excavation and preparation of aprons as well as anchor, terminal or toe trenches shall be done in accordance with the lines, grades, contours, and dimensions shown on the Contract Drawings.

4.1.3 Immediately prior to placing the fabric forms, the prepared area shall be inspected by the Engineer, and no forms shall be placed thereon until the area has been approved.

4.2 Fabric Form Placement

4.2.1 A filter fabric shall be placed on the graded surface

approved by the Engineer.

- 4.2.2 Fabric forms shall be placed over the filter fabric and within the limits shown on the Contract Drawings. Anchoring of the fabric forms shall be accomplished through the use of anchor, terminal and toe trenches.
- 4.2.3 Adjacent fabric form panels shall be joined before filling with fine aggregate concrete by field sewing or zipping the two bottom layers of fabric together and the two top layers of fabric together. All field seams shall be made using two lines of U.S. Federal Standard Type 101 stitches. All sewn seams shall be downward facing, and zipper seams shall be fastened as shown on the Contract Drawings, except with the approved of the Engineer.
- 4.2.4 When conventional joining of fabric forms is impractical or where called for in the Contract Drawings, adjacent forms may be overlapped a minimum of three feet (one meter) to form a lap joint, pending approval by the Engineer. Based on the predominant flow direction, the downstream edge of the form shall overlap the upstream edge of the next form. In no case shall simple butt joints between forms be permitted.
- 4.2.5 Expansion joints shall be provided as shown on the Contract Drawings, or as specified by the Engineer.
- 4.2.6 Immediately prior to filling with fine aggregate concrete, the assembled fabric forms shall be inspected by the Engineer, and no fine aggregate concrete shall be pumped therein until the fabric seams have been approved. At no time shall the unfilled fabric forms be exposed to ultraviolet light (including direct sunlight) for a period exceeding five days.

4.3 Fine Aggregate Concrete Placement

- 4.3.1 Following the placement of the fabric forms, small slits shall be cut in the top layer of the fabric form to allow the

insertion of the filling pipe at the end of the fine aggregate concrete pump hose. These slits shall be of the minimum length to allow proper insertion of the filling pipe. Fine aggregate concrete shall be pumped between the top and bottom layers of fabric, filling the forms to the recommended thickness and configuration.

- 4.3.2 Fine aggregate concrete shall be pumped in such a way that excessive pressure on the fabric forms and cold joints are avoided. A cold joint is defined as one in which the pumping of the fine aggregate concrete into a given form is discontinued or interrupted for an interval of forty-five or more minutes.
- 4.3.3 Holes in the fabric forms left by the removal of the filling pipe shall be temporarily closed by inserting a piece of nonwoven fabric or similar material. The nonwoven fabric shall be removed when the concrete is no longer fluid and the concrete surface at the hole shall be cleaned and smoothed by hand. Foot traffic on the filled form shall be restricted to an absolute minimum for one hour after filling.
- 4.3.4 After the fine aggregate concrete has set, all anchor, terminal and toe trenches shall be backfilled and compacted, as specified by the Engineer.
- 4.3.5 The Articulating Block Mat shall be measured by the number of square feet (square meters) computed from the payment lines shown on the Contract Drawings or from payment lines established in writing by the Engineer. This includes Articulating Block fabric forms, fine aggregate concrete, and filter fabric used in the aprons, overlaps, and anchor, terminal, or toe trenches. Slope preparation, excavation and backfilling, and bedding are separate pay items.

Spec: AB
Revised December 2001

Call or write for your complete set of HYDROTEX™ and HYDROCAST™ Specification Guidelines. Available as printed specifications, in Adobe® Acrobat® (pdf) format, or in an editable text format. PDF specifications are available for download from our web site at www.geostarcorporation.com.

Hydrotex products are manufactured by:

Geostar Corporation
74 Perimeter Center East, Suite 7420
Atlanta, Georgia 30346-1803
Tel: 1.800.253.0561 or 770.399.5051 Fax: 770.394.5999
www.geostarcorporation.com • e-mail: info@geostarcorporation.com

Hydrotex and Hydrocast are trademarks of Geostar Corporation.

© 2001 Geostar Corporation • Printed in U.S.A.

The information contained herein is furnished without charge or obligation, and the recipient assumes all responsibility for its use. Because conditions of use and handling may vary and are beyond our control, we make no representation about, and are not responsible for, the accuracy or reliability of said information or the performance of any product. Any specifications, properties or applications listed are provided as information only and in no way modify, enlarge or create any warranty. Nothing contained herein is to be construed as permission or as a recommendation to infringe any patent.

Attachment 12
Biological Assessment

**BIOLOGICAL ASSESSMENT
ADDRESSING THE PROPOSED
CENTRAL HUDSON GAS & ELECTRIC CORPORATION
FORMER NORTH WATER STREET MANUFACTURED GAS
PLANT REMEDIATION PROJECT
POUGHKEEPSIE, DUTCHESS COUNTY, NY**

U.S. ARMY CORPS OF ENGINEERS

JANUARY 2018

This page intentionally left blank.

Table of Contents

1.	Introduction.....	1-1
1.1	Endangered Species Act Requirements	1-1
1.2	Consultation History	1-2
2.	Site Location and History.....	2-1
3.	Description of the Proposed Action.....	3-1
3.1	Barrier Wall	3-1
3.2	Dredging and Capping	3-1
3.3	Restrictions on Use of the Dredged Areas	Error! Bookmark not defined.
3.4	Regulatory Jurisdiction	3-1
3.5	Description of Construction Methods.....	3-1
3.6	Construction Schedule	3-5
4.	Federally Listed Species and Designated Critical Habitat.....	4-1
4.1	Aquatic Species.....	4-1
4.1.1	Marine Mammals	4-1
4.1.2	Marine Reptiles.....	4-1
4.1.3	Marine Fishes.....	4-1
4.1.4	Aquatic Invertebrates.....	4-13
4.2	Terrestrial Species.....	4-13
5.	Environmental Baseline Conditions.....	5-1
5.1	Hudson River	5-1
5.1.1	Deepwater Habitat	5-1
5.1.2	Benthic Habitat	5-2
5.1.3	Submerged Aquatic Vegetation	5-2
6.	Potential Effects on Federally Listed Aquatic Species	6-1
6.1	Shortnose Sturgeon and Atlantic Sturgeon	6-1
6.2	Impacts on Sturgeon Prey.	6-3
7.	Remediation Activities in the Hudson River	7-1
8.	Conclusions.....	8-1
8.1	Effects Determination for Listed Species	8-1
8.2	Effects Determination for Critical Habitat.....	8-1
9.	References.....	9-1

Appendix A Dredging Figures

Appendix B Product Description Sheets – Slope Stabilization Material

List of Figures

Figure 1	Site Location.....	2-2
Figure 2	Bathymetric Contours.....	2-3
Figure 3	Dredge Areas.....	3-2
Figure 4	Silt Curtain.....	3-4
Figure 5	Benthic Invertebrate Sample Locations.....	4-7

List of Tables

Table 1	GARFO Master ESA Species Table - Shortnose Sturgeon.....	Error! Bookmark not defined.
Table 2	Benthic Invertebrates – Project Area.....	4-8
Table 3	GARFO Master ESA Species Table - Atlantic Sturgeon.....	4-12
Table 4	Summary of Impacts on Federally Listed Species by Resource Area.....	6-2
Table 5	Determination of Effect under the ESA for Federally Listed Aquatic Species in the Proposed CHGE Project Area.....	6-3

1. Introduction

The purpose of this Biological Assessment (BA) is to evaluate the potential impacts of the proposed Central Hudson Gas & Electric Corporation (CHGE) North Water Street former Manufactured Gas Plant (MGP) Site (site) Remediation Project (NWS MGP Remediation Project) on federally listed threatened or endangered species and to comply with the requirements of the Endangered Species Act (ESA) of 1973 (16 United States Code [U.S.C.] 1531–1534).

The U.S. Army Corps of Engineers (USACE) has a Federal action related to the implementation of the NWS MGP Remediation Project regarding issuance of a Rivers and Harbors Act Section 10 and Clean Water Act Section 404 permit. Other cooperating agencies involved with the BA process include the National Marine Fisheries Service (NMFS) and New York State Department of Environmental Conservation (NYSDEC). CHGE proposes to remediate the Former North Water Street Manufactured Gas Plant (MGP) site in Poughkeepsie, Dutchess County, New York in accordance with the Brownfield Cleanup Agreement (BCA) Index Number D3-0004-99-04 executed between CHGE and the NYSDEC in May 2005. Additionally, the NYSDEC selected remedy to address the environmental impacts identified at the site and in the Hudson River adjacent to the site is presented in the March 2016 *Decision Document*.

1.1 Endangered Species Act Requirements

The ESA establishes procedures for the protection and conservation of threatened and endangered species and the ecosystems upon which they depend. The ESA describes several categories of Federal status for plants and animals and their critical habitat which have been designated by the US Fish and Wildlife Service (USFWS) or NMFS. In addition to allowing the listing of species and subspecies, the ESA allows listing of “distinct population segments” (DPSs) of vertebrate species. An “endangered” species is defined as any species in danger of extinction throughout all or a large portion of its range. A “threatened” species is defined as any species likely to become an endangered species in the foreseeable future. “Critical habitat” is defined in the ESA as “a specific geographic area that is essential for the conservation of a threatened or endangered species and that could require special management or protection. Critical habitat can include an area that is not occupied by a species but is needed for the recovery of that species.

USFWS and NMFS share responsibility for implementing the ESA. Generally, the USFWS manages terrestrial and freshwater species, while NMFS manages marine and “anadromous” (i.e., born in fresh water, spends most of its life in the sea, and returns to fresh water to spawn) species. In the case of sea turtles, NMFS has the lead in the marine environment, while USFWS does on the nesting beaches.

Federal agencies must consult with USFWS and NMFS, under Section 7(a)(2) of the ESA, on activities that may affect a listed species. These interagency consultations, or Section 7 consultations, are designed to assist Federal agencies in fulfilling their duty to ensure Federal actions do not jeopardize the continued existence of a species or destroy or adversely modify critical habitat.

1.2 Consultation History

The following interactions between CHGE and USFWS or NMFS associated with the proposed CHGE Project have occurred prior to the preparation of this BA and have supported its development:

- **November 7, 2017** – Requested listing of protected species that may occur in the location of the proposed project from USFWS Information and Planning (IPaC) Website (<https://ecos.fws.gov/ipac/location/SQW6PRTQANHH5CSGMSENVWLWCA/resources>)
- **November 7, 2017** – Response letter from USFWS that provided list of threatened, endangered, proposed and candidate species, as well as proposed and final designated critical habitat, that may occur within the boundary of the proposed project and/or may be affected by the proposed project.
- **November 13, 2017** – Letter sent on behalf of CHGE to NMFS to request information on protected species that may occur in the location of the proposed project.
- **November 16, 2017** – Response letter sent by NMFS provided information on protected species that may occur in the location of the proposed project.

2. Site Location and History

The CHGE former North Water Street MGP is located at 2 Dutchess Avenue in the City of Poughkeepsie, Dutchess County, New York (Figure 1). The site is bounded by Dutchess Avenue to the north, North Water Street and Amtrak railroad lines to the east, the City of Poughkeepsie Upper Landing Park, and Fall Kill Creek to the south and Hudson River to the west. Tidal movements affect the Hudson River adjacent to the site. Figure 2 depicts the bathymetric contours of the Hudson River adjacent to the shoreline on the CHGE property.

The site was operated as a carbureted water gas MGP from 1911 to 1950. CHGE owned the site since 1926. During peak operation, waste by-products were recycled at the site and during this process, by-products were reported to have seeped into the Hudson River from unintentional spills near the tar separator. To prevent additional seepage of by-products into the river, a clay dike was installed between the railroad siding and the river in the 1940s.

The following section summarizes the key elements of the NWS MGP Remediation Project to be conducted along the shoreline and in the Hudson River adjacent to the site, which was drawn from the NYSDEC Decision Document (March 2016).

File: P:\Jobs\Rem_Eng\Project Files\CHGE\CAUD\CHGE-60540671-SL-01.dwg Layout: Layout2 User: warren Plotted: Jul 20, 2017 - 3:37pm Xref's:

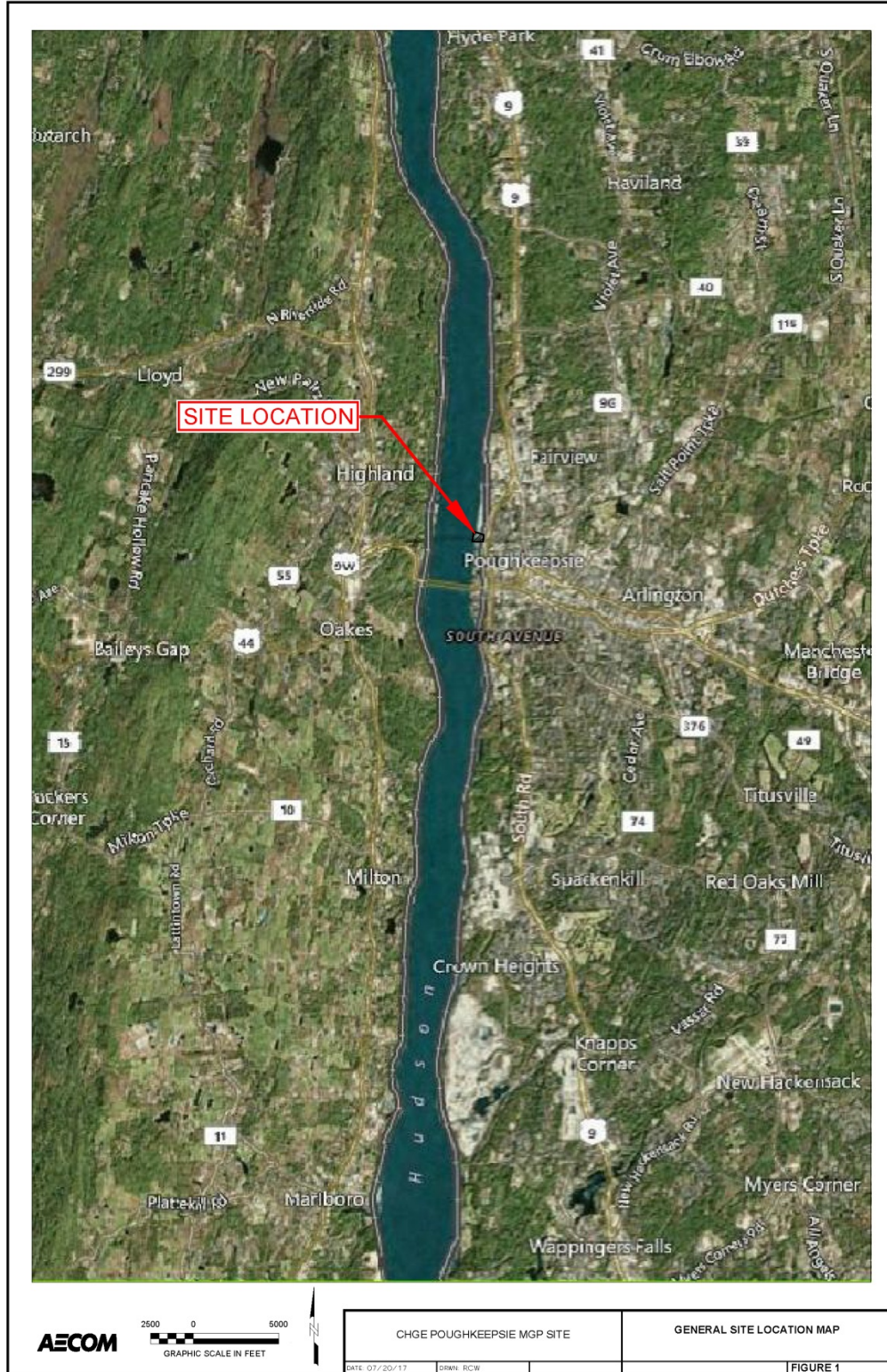

Figure 1 Site Location

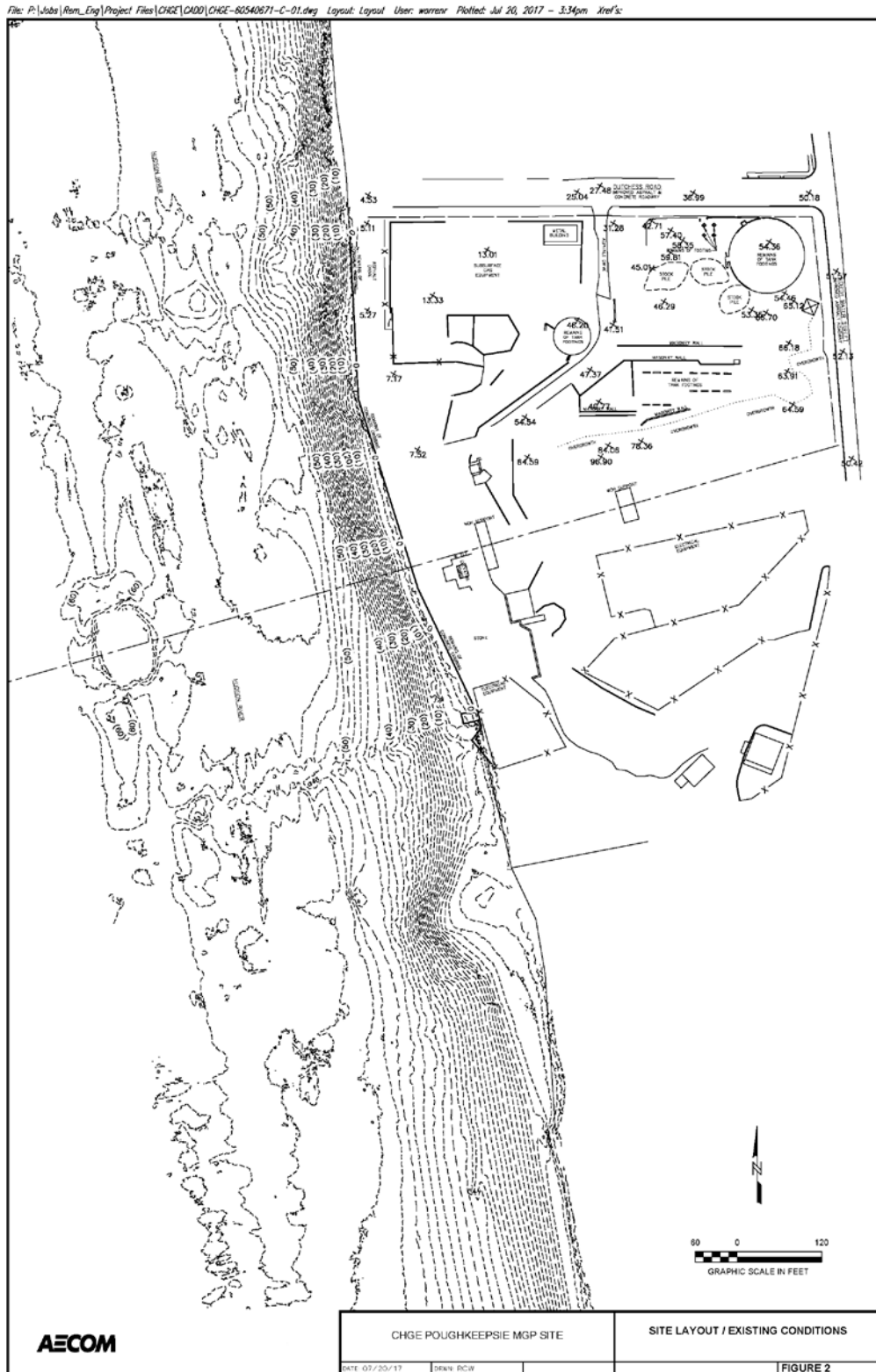

Figure 2 Bathymetric Contours

3. Description of the Proposed Action

The selected remedial actions for the shoreline and in the Hudson River include:

3.1 Barrier Wall

To prevent migration of coal tar to the river, installation of a subsurface barrier wall along the east bank of the Hudson River will be conducted. Subsequently, there will be the installation of a series of non-aqueous phase liquid (NAPL) recovery wells to collect NAPL that might accumulate behind the wall. NAPL will be collected from these recovery wells periodically.

3.2 Dredging and Capping

To remove NAPL impacted sediments from the bed of Hudson River, dredging will be conducted where feasible (Figure 3). A full set of dredging figures that depicts the various dredge areas, capping and methods is provided in Appendix A. A sand cap will be placed in select dredged areas. In areas of impacted sediment near and above the underwater utility crossings, where dredging cannot be performed, the placement of cover system consisting of Reactive Core-Mats (RCM) overlain by armored concrete blocks will be conducted (examples of sediment/slope stabilization materials are provided in Appendix B).

In areas of impacted sediment along the riverbank slope where dredging would create significant safety concerns due to potential for slope instability, an articulated capping system will be placed consisting of RCM with grout filled molds (Appendix B). The capping system will prevent migration of the remaining contamination in the riverbank into the Hudson River.

3.3 Regulatory Jurisdiction

The dredging and capping activities in the Hudson River and along the river shoreline slope are subject to the jurisdiction of the USACE. Approximately 7.6 acres of dredging (Figure 3) will be conducted in the Hudson River to remove approximately 40,000 cubic yards (CYs) of sediment impacted by the operation of the former MGP facility. There will also be approximately 1.2 acres of capping along the riverbank slope and over the utility crossings (Figure 4)

3.4 Description of Construction Methods

Dredging will be conducted using an environmental bucket within a containment cell. The containment cell will be attached to the dredge-mounted barge which will be outfitted with turbidity curtains and

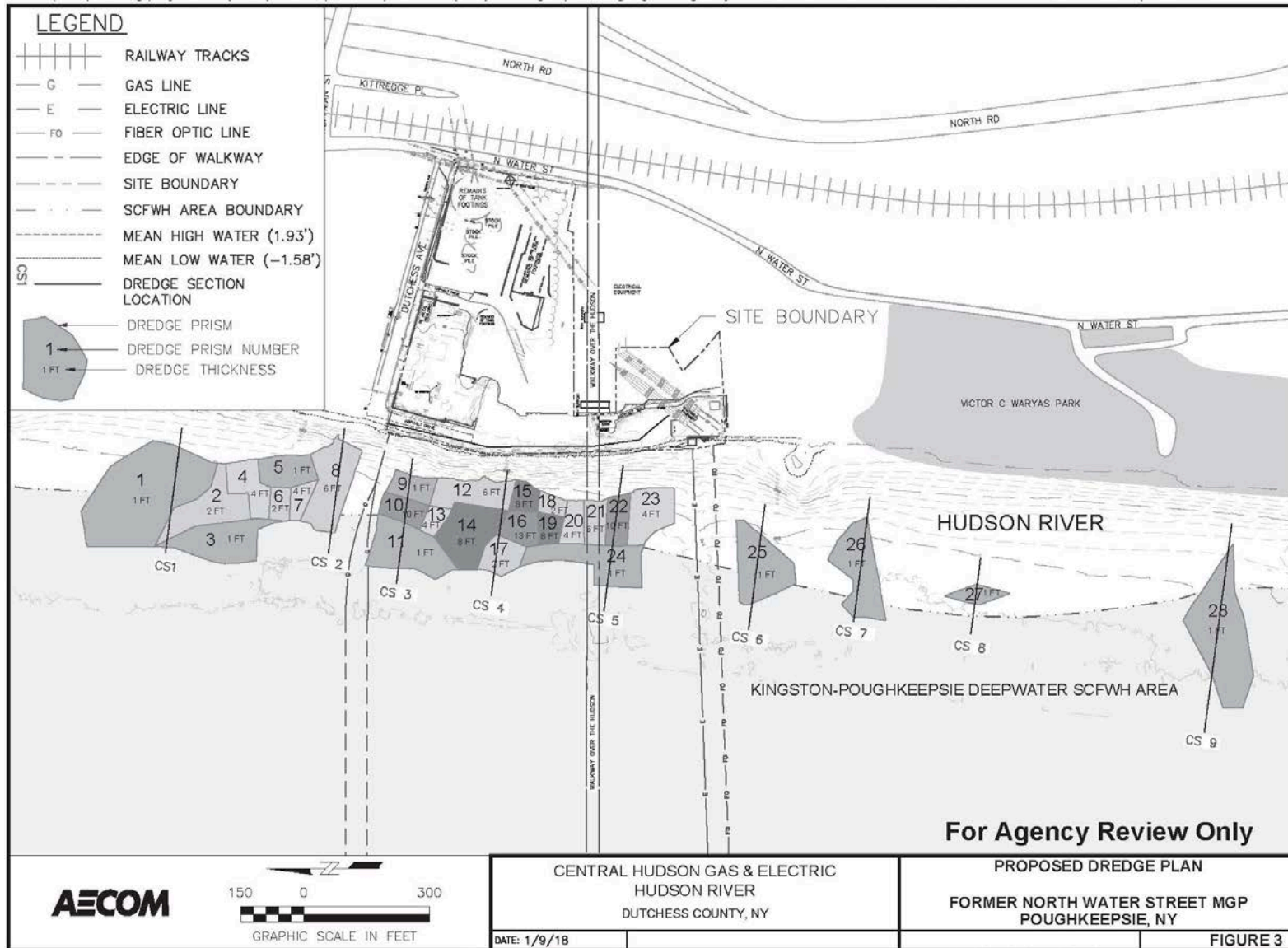

Figure 3 Dredge Areas (Proposed Dredge Plan)

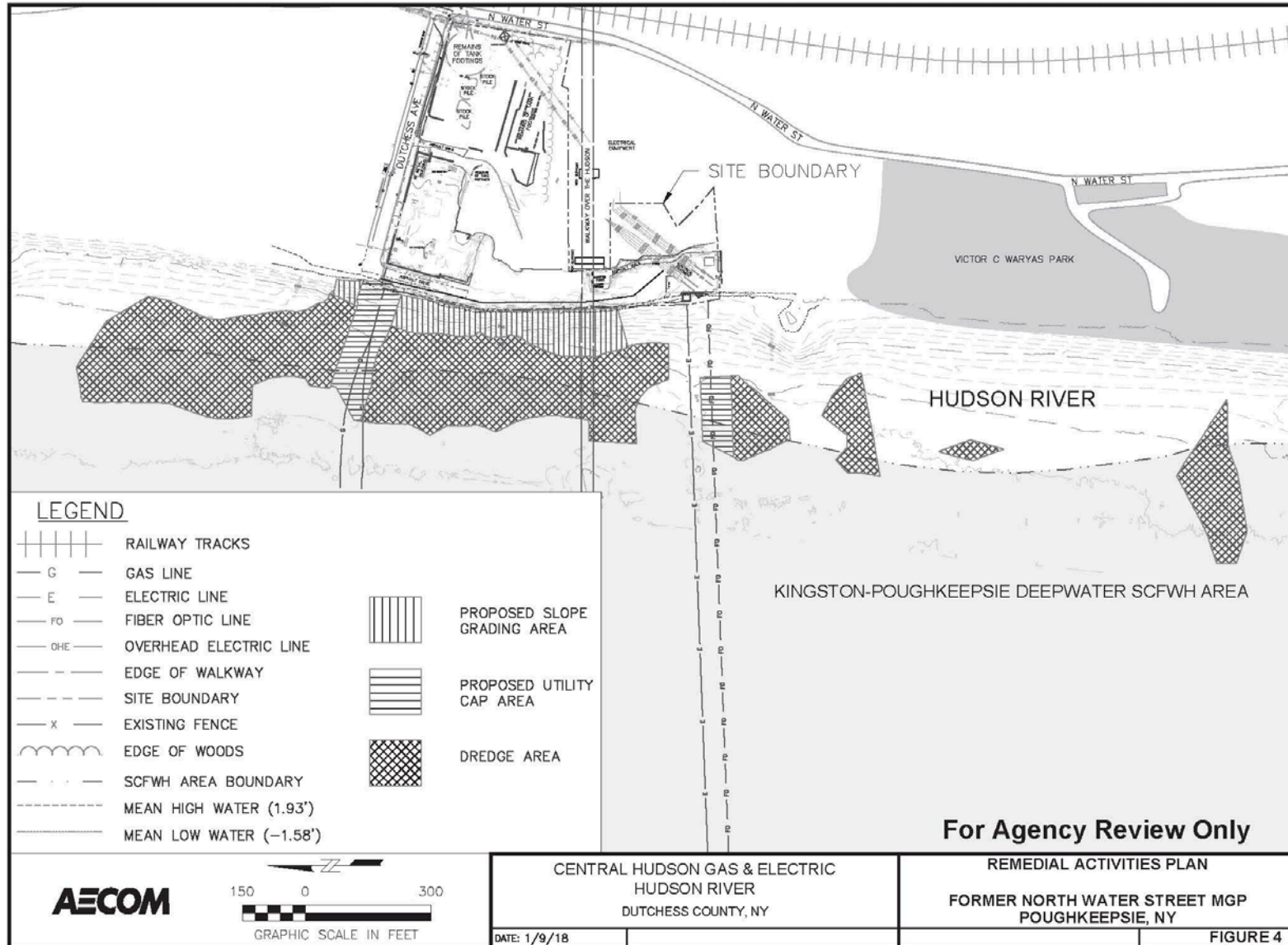

Figure 4 Dredge and Capping Areas

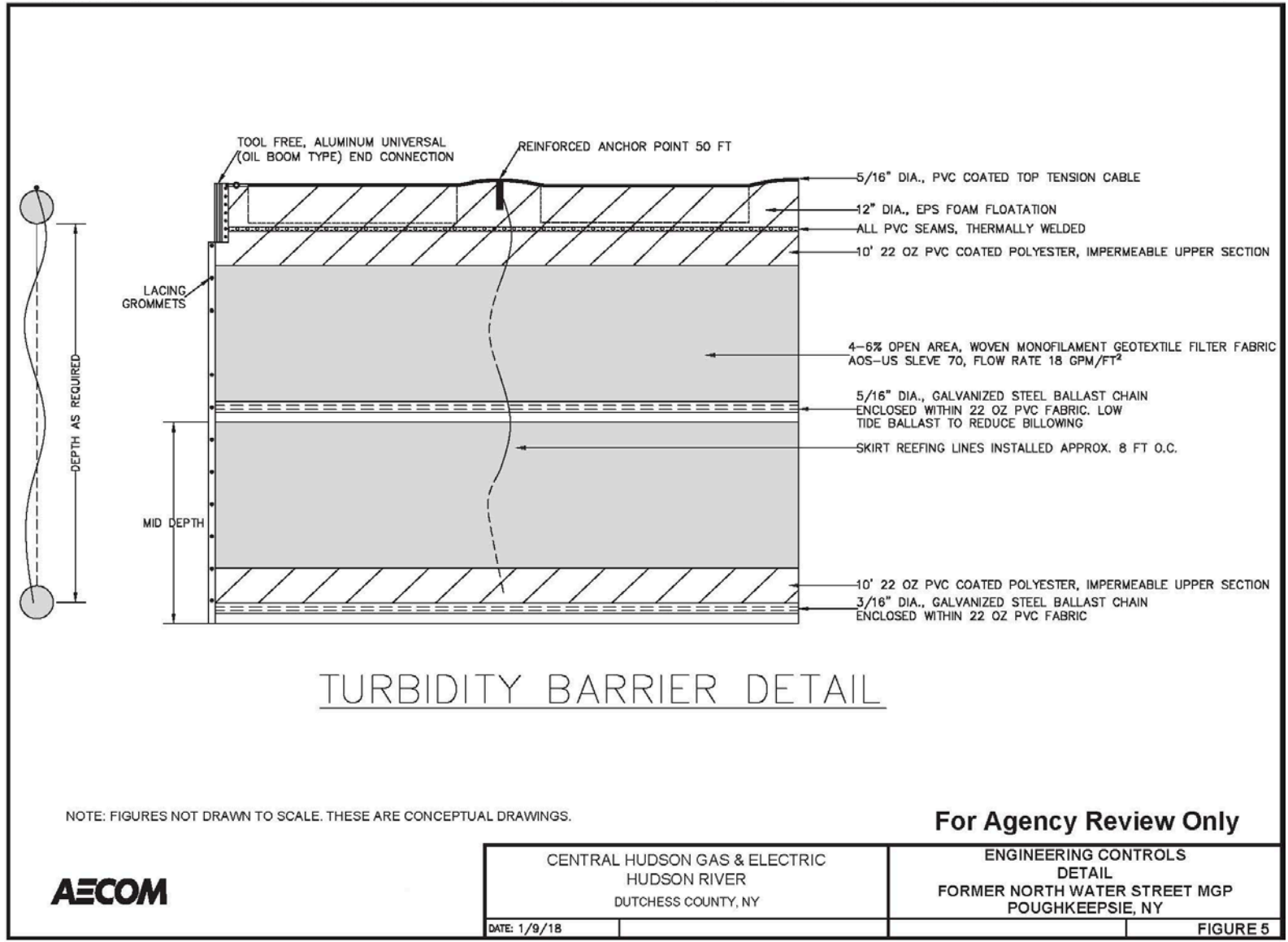

Figure 5 Silt Curtain

floating booms on all sides of the dredge polygon (Figure 5) to control the transport of contaminated sediment beyond the dredging area. Water quality (turbidity) will be monitored for the duration of the dredging by means of three buoy-mounted remote sensing stations that will be moored around the perimeter of the work area.

Dredged areas deeper than 2 feet below the existing bathymetry will be backfilled after dredging with certified clean sand (approximately 31,000 CYs) imported from upland sources and transported to the site via barge. The clean sand will be placed on approximately 4.2 acres of the dredged areas using specially fabricated conveyors and tremie technology that will discharge the sand from a tremie pipe. To the extent practicable, the tremie pipe will be constructed to extend above the dredge surface. The clean sand backfill will be placed in the dredged areas to within 2 feet of the adjacent bottom elevation to support the restoration of the river bottom to pre-dredge bathymetry. The sand will consist of a granular material of sufficient size and density that it is expected to fall through portion of the water column beyond the tremie pipe to the river bottom at its placement location with minimal dispersion. Clean sand was selected specifically to maximize accuracy of the fill placement operation and minimize suspension and transport of backfill material outside of the intended placement location.

The river bottom will be allowed to reestablish its original (pre-dredging) bathymetry within the dredged areas by natural sediment transport processes. Sediment deposition and subsequent erosion is a natural cycle within a stable riverbed; while specific rates of sedimentation and erosion in the vicinity of Poughkeepsie are not available, sedimentation rates of approximately 40 centimeters (1.3 feet) within a period of months (typically, during the spring freshet) are observed within the Lower Hudson River as a whole. Dredging of the impacted sediment will create areas of the river bottom below the surrounding bathymetry and function as natural sediment traps; consequently, it is expected that sediment transport within the dredged areas will only be depositional in nature until the pre-existing stable bathymetry is restored, after which the natural long-term deposition and erosion cycle will resume.

The slope of the shoreline along the bulkhead cannot be dredged to remove impacted sediment due to the shallow depth and stability issues with the slope. A steel sheet pile bulkhead wall will be installed as part of the upland and bulkhead remediation activities. To isolate the impacted sediment remaining beyond the sheet pile bulkhead wall from the river, approximately 1.22 acres of an articulated capping system consisting of RCM with grout filled molds will be installed along the river slope. This would require a cut volume of approximately 1,722 CY and a backfill volume of approximately 6,775 CY (Appendix A provides all related dredging figures and details, including slope and sediment stabilization materials).

Since dredging cannot be conducted in the area of the existing underwater gas, electric, and fiber optic lines that extend across the Hudson River, approximately one acre area near and over the utility crossings will be capped with a cover system consisting of RCM overlain by armored concrete blocks to isolate the impacted sediment in these areas (Figure 4).

3.5 Construction Schedule

Dredging of the contaminated sediments, identified on Figure 3, is anticipated to be conducted between October 2018 and February 2019. Additionally, the less intrusive capping of the underwater utility

crossing areas and the river slope is anticipated to be conducted between July 2019 and September 2019, after the published key migratory spawning season (March 1 through June 30).

4. Federally Listed Species and Designated Critical Habitat

4.1 Aquatic Species

The USFWS has jurisdiction over freshwater fish, amphibians, and freshwater invertebrates. The NMFS has jurisdiction over marine mammals, sea turtles, marine fish and invertebrates.

4.1.1 Marine Mammals

Six marine mammal species listed under the ESA have made rare appearances in the Hudson River or New York City Metropolitan Area segments: five large whale species: the North Atlantic right whale (*Eubalaena glacialis*), humpback whale (*Megaptera novaeangliae*), fin whale (*Balaenoptera physalus*), sei whale (*Balaenoptera borealis*), and sperm whale (*Physeter macrocephalus*); and one sirenian, the West Indian manatee (*Trichechus manatus*). Under the ESA, all whale species fall under the jurisdiction of NMFS, while the West Indian manatee is managed by USFWS. Historic unconfirmed, records of large whales up the Hudson River have been reported as far north as Troy (Kiviat and Hartwig 1994). However, large whales are uncommon in the Hudson River; individual large whales could be found occasionally at the river mouth.

Based on available occurrence records, it is unlikely that ESA-listed marine mammal species would occur in the Hudson River in the vicinity of Poughkeepsie, NY; therefore, the NWS MGP Remediation Project would have no effect on the North Atlantic right whale, humpback whale, fin whale, sei whale, sperm whale, and the West Indian manatee, and those species are not discussed further in this BA.

4.1.2 Marine Reptiles

Four sea turtle species occur seasonally during warmer months (June through mid-November) in the offshore waters of New York Bight (i.e., the bend in the shoreline from the New Jersey coast to Long Island). These are the leatherback (*Dermochelys coriacea*) (endangered), loggerhead (*Caretta caretta*) (threatened), Kemp's ridley (*Lepidochelys kempii*) (endangered), and green (*Chelonia mydas*) (threatened). NMFS and the USFWS share jurisdiction for sea turtles, with NMFS having lead responsibility for the conservation and recovery of sea turtles in the marine environment and USFWS for turtles on nesting beaches.

Based on the lack of upriver sighting records, it is unlikely that any sea turtles would occur in the Hudson River in the vicinity of Poughkeepsie, NY; therefore, the NWS MGP Remediation Project would have no effect on the leatherback, loggerhead, Kemp's ridley, and green sea turtles, and those species are not discussed further in this BA.

4.1.3 Marine Fishes

Under the authority of the ESA, USFWS and NMFS are responsible for the protection and recovery of endangered and threatened fish species. NMFS has jurisdiction over most marine fish and anadromous fish (i.e., fish that are born in fresh water, migrate to the ocean to grow into adults, and then return to

fresh water to spawn) listed under the ESA, while USFWS has jurisdiction over freshwater fish species. The only ESA-listed species that have the potential to occur in the NWS MGP Remediation Project area are the shortnose sturgeon and the Atlantic sturgeon. NMFS has jurisdiction over these fish species that could be affected by the NWS MGP Remediation Project. Details on the life history and occurrence patterns of these species are discussed in the following sections.

Shortnose Sturgeon

The following description of the shortnose sturgeon (*Acipenser brevirostrum*) comes primarily from the following sources, which are incorporated by reference.

- *Recovery Plan for the Shortnose Sturgeon (NMFS 1998)*
- *A Biological Assessment of Shortnose Sturgeon (Acipenser brevirostrum) (SSSRT 2010)*
- *Biological Assessment for the Tappan Zee Hudson River Crossing Project (FHWA 2012)*
- *Biological Opinion for the Tappan Zee Bridge Replacement Project (NMFS 2013a)*
- *Biological Opinion for Continued Operations of Indian Point Nuclear Generating Unit Nos. 2, 5 and 3 (NMFS 2013b).*
- *Revised Biological Assessment for Champlain Hudson Power Express Transmission Line Project (USDOE 2014)*
- GARFO Master ESA Species Table - Shortnose Sturgeon (NMFS Web site https://www.greateratlantic.fisheries.noaa.gov/protected/section7/listing/garfo_master_esa_species_table_-_shortnose_sturgeon_may2017.pdf). Accessed December 8, 2017.

Status. The shortnose sturgeon was listed as endangered in 1967 under the Endangered Species Preservation Act that pre-dated the ESA (32 *Federal Register* 4001). NMFS manages the species and recognizes 19 separate populations of shortnose sturgeon. Individuals occurring in the NWS MGP Remediation Project area belong to the endangered Hudson River population, which is the largest population of shortnose sturgeon, with an estimated 65,000 individuals (USFWS 2009). There is no designated or proposed designated critical habitat for the shortnose sturgeon, so the NWS MGP Remediation Project would have no effect on critical habitat (NOAA 2013, USFWS 2014).

Behavior and Life History. The shortnose sturgeon primarily occurs in freshwater rivers and coastal estuaries. The species is considered freshwater amphidromous, meaning its use of marine waters is limited to the estuaries of its home rivers (Bain 1997). Spawning occurs in upper freshwater areas, while feeding and overwintering activities could occur in both freshwater and saline habitats (NMFS 1998, SSSRT 2010). While the shortnose sturgeon does not undertake the significant marine migrations seen in the Atlantic sturgeon, telemetry data indicate that shortnose sturgeons do make localized coastal migrations. For example, one individual tagged in the Hudson River was recaptured in the Connecticut River (Welsh et al. 2002).

The shortnose sturgeon is a long-lived species (30 to 40 years) that matures at late ages (males attain sexual maturity at 6 to 10 years of age, while females do so between 7 and 13 years) (NMFS 1998). Males

spawn approximately every 2 years, while females spawn every 3 to 5 years. Generally, shortnose sturgeons spawn in gravel- to boulder-sized substrate in April to May. Studies indicate that the spawning period lasts from a few days to several weeks and begins when freshwater temperatures increase from 46 to 48°F (8 to 9 °C), early April through May (NYSDEC 2013a, Dovel et al. 1992). Larvae tend to drift downstream and are generally found between Albany and Poughkeepsie, New York (NatureServe 2017, NYNHP 2010a). Larvae can be found upstream of the saltwater wedge (i.e., a wedge-shaped intrusion of salty ocean water into a tidal river; it slopes downward in the upstream direction, and salinity increases with depth) in the Hudson River estuary and are most commonly found in deep waters with strong currents, typically in the channel (Dovel et al. 1992, Bain 1997). Most activity of larvae, juveniles, and adults appears to occur at night (NatureServe 2017). Juvenile shortnose sturgeons in the Hudson River typically use the same deep channel habitats throughout the tidal reach as adults (Bain 1997).

In northern rivers (e.g., the Hudson River), the shortnose sturgeon feeds in fresh water during summer and over sand-mud bottoms in the lower estuary during fall, winter, and spring (NMFS 1998). Shortnose sturgeons are bottom feeders; their mouths are designed to suck up prey from the river bottom. Juveniles eat available benthic crustaceans and insects. Adults in fresh water feed on mollusks, crustaceans, and insect larvae depending on availability, and, in estuaries, their primary foods are polychaete worms, crustaceans, and mollusks (NatureServe 2017).

Distribution and Habitat. In New York State, the shortnose sturgeon is found in the Hudson River from the Federal Dam at Troy downriver to the southern tip of Manhattan, over a large portion of the fresh and brackish reaches in deep channel habitats (Bain 1997, Bain et al. 2000). All life stages occur in the lower Hudson River. Non-spawners use overwintering habitat concentrated in brackish waters of the lower Hudson River while spawners (in the upcoming spring) overwinter in a single concentration in deep channel habitats further upstream (Bain 1997). Adults migrate upriver from their middle Hudson River overwintering areas to freshwater spawning sites north of Coxsackie, New York when water temperatures reach 46 to 48 °F (8 to 9 °C) (NYSDEC 2013a, Dovel et al. 1992).

Shortnose sturgeon have been found in waters with temperatures as low as 36 to 37 °F (2 to 3 °C) and as high as 93 °F (34 °C) (Dadswell et al. 1984). Water temperatures above 82 °F (28 °C) are thought to adversely affect shortnose sturgeon. Shortnose sturgeon are known to occur at depths of up to 98 feet (30 meters) but are generally found in waters less than 66 feet (20 meters) (Dadswell et al. 1984). Adults occur in both freshwater and upper tidal saline areas all year. Juveniles (age of 3 to 10 years) generally occur at the saltwater/freshwater interface (i.e., salt front) (Dovel et al. 1992).

Spawning grounds extend from below the Federal Dam at Troy downriver to around Coeymans, New York (Dovel et al. 1992). Spawning typically occurs at water temperatures between 50 and 64 °F (10 and 18 °C) (generally early April through May). Shortnose sturgeon eggs are expected to hatch in 8 to 13 days and embryos gradually disperse downstream over much of the Hudson River estuary. Shortnose sturgeon larvae captured in the Hudson River were associated with deep waters and strong currents (Hoff et al. 1988 as cited in Bain 1997). Juvenile shortnose sturgeon are predominantly found in deep channels in mid-river region in the mid-summer (Hoff et al. 1998 and Pekovitch 1979 as cited in Bain 1997). After spawning, adults disperse quickly down river into their summer range. The broad summer range occupied by adult shortnose sturgeon extends from just south of Catskill, New York, downriver to the Palisades area near the border of New York and New Jersey. Similar to non-spawning adults, most juveniles occupy

the broad region of Haverstraw Bay by late fall and early winter (Dovel et al. 1992). Migrations from the summer foraging areas to the overwintering grounds are triggered when water temperatures fall below approximately 46 °F (8 °C), which typically occurs in late November (NMFS 1998). Juveniles are distributed throughout the mid-river region during the summer and move back into the Haverstraw Bay region during the late fall.

From late fall to early spring, adult shortnose sturgeon concentrate in a few overwintering areas. Reproductive activity the following spring determines overwintering behavior. The largest overwintering area is just south of Kingston, New York, near Esopus Meadows (Dovel et al. 1992). The fish overwintering at Esopus Meadows are mainly spawning adults. Captures of shortnose sturgeon during the fall and winter from Saugerties to Hyde Park (greater Kingston reach), indicate that additional smaller overwintering areas may be present (Geoghegan et al. 1992). An overwintering site in the Croton-Haverstraw Bay area has also been confirmed (Geoghegan et al. 1992, Dovel et al. 1992). Fish overwintering in areas below Esopus Meadows are mainly thought to be pre-spawning adults. Typically, movements during overwintering periods are localized and fairly sedentary. The shortnose sturgeon prefers deep channel habitats during the winter season.

Shortnose sturgeon eggs and larvae are limited to the low salinity waters near spawning grounds, and young of the year are also restricted to areas of low salinity. The shortnose sturgeon spawning grounds in the Hudson River are greater than 125 miles [48 km] upstream from the Harlem and East rivers.

The Greater Atlantic Regional Fisheries Office (GARFO) of the NMFS has prepared information on the use of the watersheds where shortnose sturgeon are found; this information is available on their Web site and is presented in Table 1 below.

Threats. Throughout the shortnose sturgeon's range, habitat degradation or loss (resulting, for example, from dams, bridge construction, channel dredging, and pollutant discharges) and mortality (resulting, for example, from impingement on cooling water intake screens, dredging and incidental capture in other fisheries) are the principal threats to survival (NMFS 1998).

Atlantic Sturgeon

The following description of the Atlantic sturgeon (*Acipenser oxyrinchus oxyrinchus*) comes primarily from the following sources, which are incorporated by reference.

- *Status Review of Atlantic Sturgeon (Acipenser oxyrinchus oxyrinchus) (ASSRT 2007)*
- *Biological Assessment for the Tappan Zee Hudson River Crossing Project (FHWA 2012)*
- *Biological Opinion for the Tappan Zee Bridge Replacement Project (NMFS 2013a)*
- *Biological Opinion for Continued Operations of Indian Point Nuclear Generating Unit Nos. 2 and 3 (NMFS 2013b).*
- *Revised Biological Assessment for Champlain Hudson Power Express Transmission Line Project (USDOE 2014)*
- GARFO Master ESA Species Table – Atlantic Sturgeon (NMFS Web site https://www.greateratlantic.fisheries.noaa.gov/protected/section7/listing/garfo_master_esa_speci es_table_-_atlantic_sturgeon_051917.pdf). Accessed December 8, 2017

Table 1 GARFO Master ESA Species Table - Shortnose Sturgeon

Body of Water	Distribution/Range in Watershed	Life Stages Present	Use of the Watershed	References
Hudson River	up to the Troy Dam (approximately river kilometer (RKM) 246)	eggs, larvae, YOY, juveniles, subadults, and adults	<p>Spawning - Documented from late March to early May when water temperatures reach 10°-18°C[1] from Coxsackie to below the Federal Dam at Troy[1][3] (RKM 190-246) Rearing - Eggs on the spawning grounds; larvae downstream to at least RKM 104; YOY downstream to at least RKM 64[1] Foraging - Throughout the Hudson River[3] (RKM 38-166) with concentrations in Haverstraw Bay[1] (RKM 56-64) Overwintering - Late fall to early spring[3]; largest area (mainly spawning adults) near Kingston[2] (RKM 137-149); smaller overwintering areas are located from Saugerties to Hyde Park[2] (RKM 123-170) and in the Croton-Haverstraw Bay area[2] (RKM 54-61); many juveniles overwinter in the lower river[1] (RKM 0-64)</p>	Dovel and Berggren 1983; Coch 1986; Van Eenennaam et al. 1996; Bain 1997; Kahnle et al. 1998; Bain et al. 1998, 2000; Savoy and Pacileo 2003; Sweka et al. 2006; ASSRT 2007; Normandeau Associates, Inc. 2014

Status. The Atlantic sturgeon is not listed as threatened or endangered, there are five DPSs that are listed: threatened Gulf of Maine DPS, endangered New York Bight DPS, endangered Chesapeake Bay DPS, endangered Carolina DPS, and South Atlantic DPS. Individuals from any of these five DPSs could occur in the NWS MGP Remediation Project area (Colligan 2012). Based on genetic sampling of Atlantic sturgeon captured within the Hudson River, three DPSs are most likely to occur in the Hudson River (ranked largest to smallest): New York Bight DPS, Gulf of Maine DPS, and Chesapeake Bay DPS (NMFS 2013b, 77 *Federal Register* 5880). Based on the previously mentioned genetic sampling, the majority of Atlantic sturgeon in the Hudson River are likely to be of the New York Bight DPS. In the New York Bight DPS, there are two known spawning populations: those in the Hudson and Delaware rivers. Currently, the existing spawning population in the Hudson River is estimated to have 870 adults spawning each year (600 males and 270 females), and there is no indication that the population is increasing (77 *Federal Register* 5880).

On August 17, 2017, critical habitat was designated for the Endangered New York Bight, Chesapeake Bay, Carolina and South Atlantic Distinct Population Segments of Atlantic Sturgeon and the Threatened Gulf of Maine Distinct Population Segment of Atlantic Sturgeon (82 *Federal Register* 39160). This Final Rule became effective September 18, 2017. Critical habitat has been designated for the Atlantic sturgeon in the Hudson River from the southern end of Manhattan, NY to the Troy Lock and Dam in Rensselaer County, NY.

Section 4(b)(8) of the ESA identifies those activities that may destroy or adversely modify such habitat or that may be affected by such designation. A wide variety of activities may affect critical habitat and, when carried out, funded, or authorized by a Federal agency, will require an ESA section 7 consultation because they may affect one or more of the PBFs of critical habitat; such activities include dredging.

In December 2017, sampling to identify benthic invertebrates was conducted in the project area. Benthic samples were obtained through the use of a Van Veen Grab sampler. The grab collected to collect sediments from the Hudson River bottom. The grab sample was then brought to the surface and the sediments were washed away over a screen table. The remaining contents were then placed in a container with a preservative and biological stain. Later, the remaining materials were examined with a microscope and all species were identified to the lowest possible taxon. Nine mid-stream, three shoreline and two reference locations¹ were sampled (Figure 5).

As can be observed in Table 2 below, a typical assemblage of Hudson River benthic invertebrates were observed in both the dredge prism areas and the reference locations. Due to composition substrate along the shoreline, two of the three shoreline sites were unable to produce fine-grained sediment samples, and at the one that collected a sample only zebra mussels and one blue mussel shell was observed. The zebra mussel, an invasive species, was observed at several locations. Blue mussel shell fragment were observed at several sample locations, but only the two reference sites and Location 27 samples yielded any live species. Some amphipods were observed at most sites but were not observed at either of the reference sites. Other species observed in small quantities at some sites include isopods, clams, midge larvae, American eel, and snails, although often samples contained only fragments rather than live specimen. Many of the samples exhibited a strong odor or sheen, likely as a result of historic contamination.

¹ Reference Locations 1 was located approximately 2,500 feet north of Dutchess Avenue off the eastern shoreline. N 41.718205, W -73.939893
Reference Location 2 was located approximately 2,900 feet northwest of Dutchess Avenue off the western shoreline. N 41.716921, W-73.948095

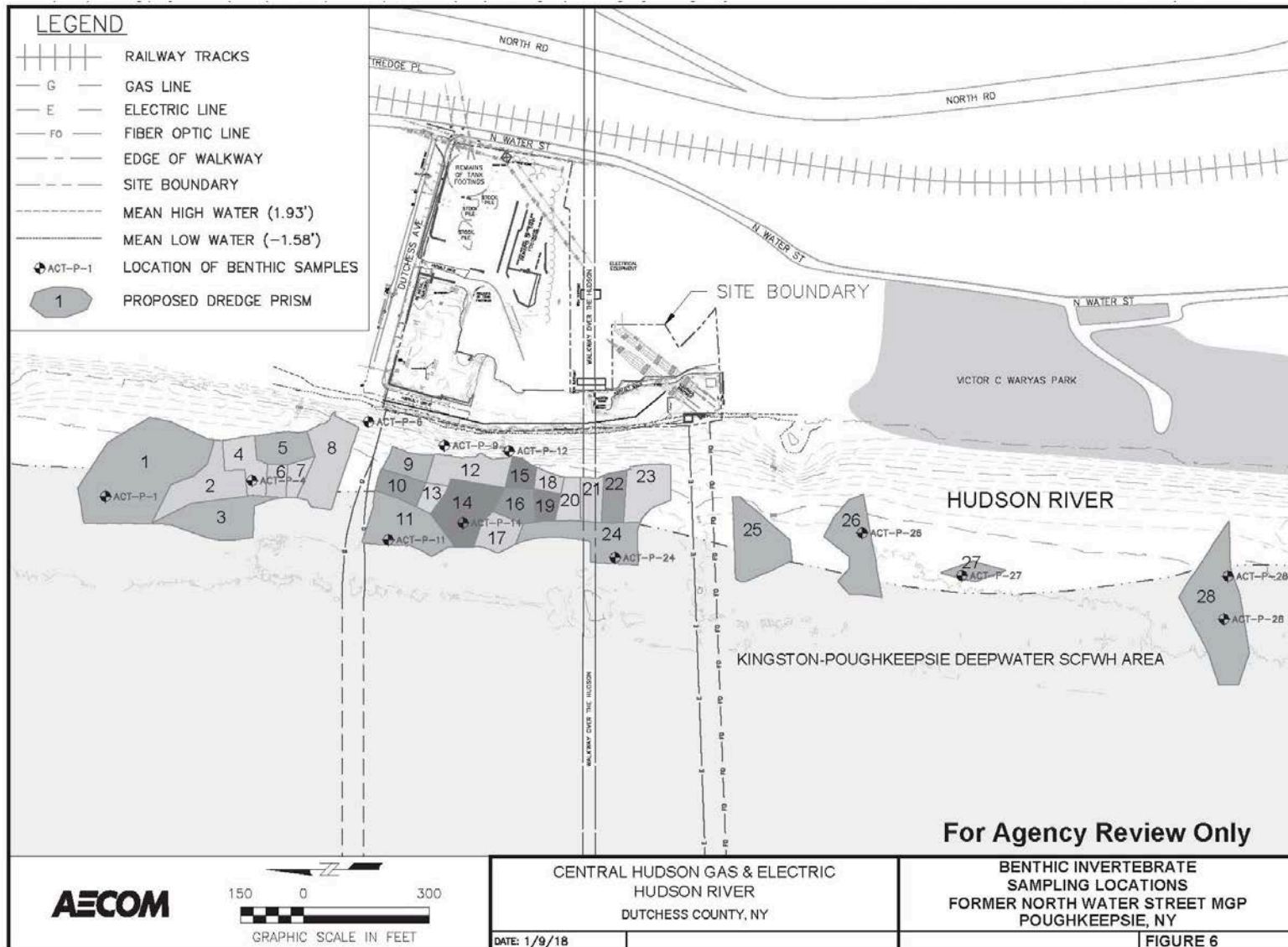

Figure 6 Benthic Invertebrate Sample Locations

Table 2
Benthic Invertebrates – Project Area

Site ^a	Depth ^b (feet below surface)	Substrate Composition	Zebra mussel ^c (<i>Dreissena polymorpha</i>)	Amphipod (<i>Gammaridea</i> sp.)	Slender Isopod (<i>Cyathura</i> sp.)	Asian clam (<i>Corbicula</i> sp.)	Midge larvae (<i>Chironomidae</i> sp.)	Blue mussel (<i>Mytilus edulis</i>)	American eel (<i>Anguilla rostrata</i>)	Insecta sp.	Bivalve sp.	Faucet snail (<i>Bithynia tentaculata</i>)	Gastropod sp.	Other
ACT-P-1	54	Silt, some coarse sand and leaf litter.	20	1										Woody detritus, some black grit, few pieces of gravel. 1 hogchocker flounder.
ACT-P-4	55	Silt, some coarse sand and leaf litter.	10	5				1 SF						Woody detritus with some leaves. Sheen and odor of MGP product.
ACT-P-11	60	Silt.	25											Woody detritus with some black grit. Sheen and odor.
ACT-P-14	53	Silt, some coarse sand.	15	4		1	2		1					Woody detritus with some tar blobs. Some sheen.
ACT-P-24	56	Silt, some gravel, some coarse sand, shells, rock and brick fragments.	205	3				1 SF						Some gravel with slag, coarse sand and black grit. Strong odor.
ACT-P-26	53	Silt, some gravel and coarse sand.	23			2	1				1 SF			Some gravel, coarse sand and black grit. Woody detritus, gravel and slag. Sheen and odor.

Site ^a	Depth ^b (feet below surface)	Substrate Composition	Zebra mussel ^c (<i>Dreissena polymorpha</i>)	Amphipod (<i>Gammaridea</i> sp.)	Slender Isopod (<i>Cyathura</i> sp.)	Asian clam (<i>Corbicula</i> sp.)	Midge larvae (<i>Chironomidae</i> sp.)	Blue mussel (<i>Mytilus edulis</i>)	American eel (<i>Anguilla rostrata</i>)	Insecta sp.	Bivalve sp.	Faucet snail (<i>Bithynia tentaculata</i>)	Gastropod sp.	Other
ACT-P-27	58	Silt, some shells.	210					4 live, 3 SF						Gravel, slag, some black grit. Sheen and odor of free product.
ACT-P-28	52	Silt, some shells.	126	2		3 SH	2	1 SF	1	1 WF				Woody detritus with some coarse sand, black grit and shell fragments.
ACT-P-28B	55	Silt, some shells.	300	7	1			6 SF						Gravel, some slag, coarse sand and grit.
ACT-P-12	25	Refusal, no sample collected. 1 large stone encrusted with zebra mussels.												No sample collected.
ACT-P-9	30	Refusal, no sample collected.												No sample collected.
ACT-P-6	20	Silt, some coarse sand and gravel.	25					1 SF				1		Rocks, gravel, slag, coarse sand, and black grit, some woody detritus.
Reference 1	51	Silt, some shells.	21			1	1	1 live, 2 SF						Gravel with coal, slag, coarse sand, black grit, and woody detritus. Some sheen.
Reference 2	35	Silt.	300					1 live				1	1 EF	Woody detritus with some black grit, gravel, sticks, slag, and coarse sand.

Notes: Three samples were collected at each site location. Results show the aggregate of the three samples.

- a. Indicates the average depth of the three samples.
- b. Zebra mussel counts include shells and fragments.
- c. SF = Shell Fragment; SH = Shell; WF = Wing Fragment; Eroded/Fossilized Shell

Also, within the dredge prisms, some of the benthic habitat would be considered impaired as it contains NAPL or other debris materials. This may contribute to the lack of abundance or diversity in many of the samples, including nearby reference samples.

Behavior and Life History. Atlantic sturgeon are long-lived (approximately 60 years), late-maturing, estuarine-dependent, anadromous fish (i.e., adults spawn in fresh water in the spring and early summer and migrate into estuarine and marine waters where they spend most of their lives). In the Hudson River, the Atlantic sturgeon matures at 11 to 21 years (ASSRT 2007). Males spawn approximately every 1 to 5 years and females every 2 to 5 years.

Eggs are deposited on hard-bottom substrate (e.g., cobble, coarse sand, and bedrock) (Greene et al. 2009). After hatching, larval fish move downstream at night and seek refuge during the day. As larval fish make their way downstream, they grow and become more tolerant of brackish and saline waters, and eventually reside entirely in estuarine waters (for 2 to 6 years) until they reach sub-adulthood and move into the open ocean (Bain 1997). Locations of sonic-tagged juvenile sturgeons revealed that individuals are found most often in dynamic mud habitat (ASMFC 2008). When juveniles begin to emigrate they travel widely along the Atlantic Coast and its estuaries.

Atlantic sturgeons are bottom-feeders that suck food into their mouths. Diets of adult and migrant sub-adult Atlantic sturgeon include mollusks, gastropods, amphipods, annelids, decapods, isopods, and fish (e.g., sand lance). Juvenile Atlantic sturgeon feed on aquatic insects, insect larvae, and small invertebrates (ASSRT 2007). Adults feed primarily on benthic worms (e.g., polychaetes), crustaceans, and mollusks (NOAA 2013).

Distribution and Habitat. Spawning generally occurs between May and July in the Hudson River (Bain 1997, Bain et al. 2000). Male sturgeons begin upstream spawning migrations when waters reach approximately 43 °F (6 °C), and remain on the spawning grounds throughout the spawning season. Females begin spawning migrations when temperatures are warmer at 54 to 55 °F (12 to 13 °C), make rapid spawning migrations upstream, and quickly depart following spawning (Greene et al. 2009).

Spawning likely occurs in multiple sites within the Hudson River in the vicinity of the NWS MGP Remediation Project from RMs 254 to 269 (Dovel and Berggren 1983, Van Eenennaam et al. 1996, Kahnle et al. 1998, Bain et al. 2000). Spawning sites in a given year can be influenced by the position of the salt wedge (where the salt water from the estuary meets the fresh water of the river) (Dovel and Berggren, 1983, Van Eenennaam et al. 1996, Kahnle et al. 1998). The area around Hyde Park (RM 254) has consistently been identified as a spawning area through scientific studies and historical records of the Hudson River sturgeon fishery. Habitat conditions near Hyde Park site are fresh water year-round with bedrock, silt, and clay substrates and water depths of 40 to 80 feet (12 to 24 meters) (Dovel and Berggren 1983, Van Eenennaam et al. 1996, Kahnle et al. 1998, Bain et al. 2000). A spawning site near New Hamburg near RM 266 has also been identified based on tracking data; has clay, silt, and sand substrates; and is approximately 70 to 90 feet (21 to 27 meters) deep (Bain et al. 2000, NMFS 2014). Larvae are expected to occur from June through August in the vicinity of the spawning area (Bain et al. 2000).

Juvenile Atlantic sturgeon have been recorded in the Hudson River between approximate RMs 245 (near Kingston, New York) and 295 (north of Haverstraw Bay), which includes some brackish waters; however, larvae must remain upstream of the salt wedge because of their low salinity tolerance (Dovel and Berggren 1983, Kahnle et al. 1998, Bain et al. 2000). Catches of immature sturgeon (age 1 and older) suggest that juveniles use the estuary from Kingston to the Tappan Zee Bridge (RMs 245 to 310).

Seasonal movements are apparent with juveniles occupying waters from RMs 270 to 295 during summer months and then moving downstream as water temperatures decline in the fall, primarily occupying waters in the vicinity of the NWS MGP Remediation Project from RMs 290 to 324 (Dovel and Berggren 1983, Bain et al. 2000). Based on river-bottom sediment maps (Coch 1986), most juvenile sturgeon habitats in the Hudson River have clay, sand, and silt substrates (Bain et al. 2000). Newburgh and Haverstraw Bays in the Hudson River are areas of known juvenile sturgeon concentrations. Sampling in spring and fall revealed that highest catches of juvenile Atlantic sturgeon occurred during the spring in soft-deep areas of Haverstraw Bay, even though this habitat type composed only 2 percent of the available habitat in the bay. Overall, 90 percent of the total 562 individual juvenile Atlantic sturgeon captured during the course of this study came from Haverstraw Bay (Sweka et al. 2007). At around 3 years of age, Hudson River juveniles exceeding 28 inches (70 cm) in length begin to migrate to marine waters (Bain et al. 2000, NMFS 2014). It has also been reported that older juveniles and post-spawn adult sturgeon congregate in deepwater habitat during the summer in the Hudson River (Bain et al. 2000). Sonic-tagged spawning adults were detected in the river as early as April and as late as October (ASMFC 2008).

After emigration from the natal estuary, sub-adults and adults travel within the marine environment, typically in waters less than 164 feet (50 meters) in depth, using coastal bays, sounds, and ocean waters. Satellite-tagged adult sturgeon from the Hudson River concentrate in the southern part of the Mid-Atlantic Bight at depths greater than 66 feet (20 meters) during winter and spring, and in the northern portion of the Mid-Atlantic Bight at depths less than 66 feet (20 meters) in summer and fall (Erickson et al. 2011). Atlantic sturgeon adults and sub-adults that are not spawning live in coastal and estuarine conditions, generally in shallow water (33 to 164 feet [10 to 50 meters]) in nearshore areas dominated by gravel and sand (Greene et al. 2009).

The Greater Atlantic Regional Fisheries Office (GARFO) of the NMFS has prepared information on the use of the watersheds where Atlantic sturgeon are found; this information is available on their Web site and is presented in Table 3 below.

Threats. Unintended catches of Atlantic sturgeon in fisheries, vessel strikes, poor water quality, water availability, dams, lack of regulatory mechanisms for protecting the fish, and dredging are the most significant threats to Atlantic sturgeon (77 *Federal Register* 5880, 77 *Federal Register* 5914).

Table 3

GARFO Master ESA Species Table - Atlantic Sturgeon

Body of Water	Distribution/Range in Watershed	Life Stages Present	Use of the Watershed	References
Hudson River	up to the Troy Dam (approximately RKM 246)	eggs, larvae, YOY, juveniles, subadults, and adults	<p>Spawning - late spring to summer around Hyde Park (RKM 134), Catskill (RKM 182), and around RKM 112; evidence strongly suggests that there is also spawning further upstream of RKM 193</p> <p>Rearing - eggs - RKM 60-148; larvae - summer; remain upstream of the salt wedge; vicinity of spawning area; YOY: between RKM 60-148; juveniles - spring through fall in RKM 68-107; utilize the estuary from the Tappan Zee Bridge through Kingston (RKM 43-148); occupy waters from RKM 37-66 during the summer; Newburgh and Haverstraw Bays (RKM 55- 61) are areas of known juvenile concentrations</p> <p>Foraging - tidally influenced flats; may be using the lower Hudson River for foraging in the summer</p> <p>Overwintering - may be using the lower Hudson River from winter; juveniles - RKM 19-74 from fall through winter</p>	<p>Dovel and Berggren 1983; Coch 1986; Van Eenennaam et al. 1996; Bain 1997; Kahnle et al. 1998; Bain et al. 1998, 2000; Savoy and Pacileo 2003; Sweka et al. 2006; ASSRT 2007; Normandeau Associates, Inc. 2014</p>

4.1.4 Aquatic Invertebrates

The dwarf wedgemussel (*Alasmodonta heterodon*) is an ESA endangered freshwater mollusk species that occurs in New York State. Its extent is limited to a small area within the upper Delaware River watershed in Sullivan and Delaware counties, and in one of its major downstream tributaries, the lower Neversink River in Orange County (NatureServe 2017, NYSDEC 2013b). Since the dwarf wedgemussel does not occur in the NWS MGP Remediation Project area, the NWS MGP Remediation Project would have no effect on this species.

4.2 Terrestrial Species

Under the authority of the ESA, USFWS is responsible for the protection and recovery of endangered and threatened terrestrial species. The terrestrial species that are federally listed, or are proposed for Federal listing, that have previously been identified in the vicinity of the NWS MGP Remediation Project area are identified in the letter from the USFWS dated November 7, 2017 and discussed below.

Indiana Bat

Status. The Indiana bat (*Myotis sodalists*) was officially listed as an endangered species on March 11, 1967 (32 *Federal Register* 4001). Critical habitat was designated for the species on September 24, 1976 (41 *Federal Register* 14914). Thirteen hibernacula, including eleven caves and two mines in six states, were listed as critical habitat; however, there is no designated or proposed designated critical habitat for this species in New York State. The following description of the Indiana bat comes primarily from the following sources, which are incorporated by reference.

- *Indiana Bat Recovery Plan (USFWS 1983)*
- *Revised Draft Recovery Plan for the Indiana Bat (USFWS 2007)*
- *Indiana Bat Five-Year Review (USFWS 2009)*
- *Biological Assessment, Indiana Bat (Myotis sodalists), St. Lawrence Windpower Project, Jefferson County, New York (Young et al. 2010)*
- *Revised Biological Assessment for Champlain Hudson Power Express Transmission Line Project (USDOE 2014)*

Behavior and Life History. The Indiana bat is a temperate, insectivorous, migratory bat that hibernates in caves and mines in the winter (typically October through April) and summers in wooded areas. It is a medium-sized bat 1.5 to 2 inches long, having a wingspan of 9 to 11 inches (23 to 28 cm), and weighing approximately only one-quarter of an ounce. It has brown to dark-brown fur and the facial area often has a pinkish appearance. The Indiana bat feeds primarily on aquatic and terrestrial insects. Diet varies seasonally and variations exist amongst different ages, sex, and reproductive status (USFWS 1999). Indiana bats forage in closed to semi-open forested habitats and forest edges located in floodplains, riparian areas, lowlands, and uplands.

In Illinois, Gardner et al. (1991) found that forested stream corridors, and impounded bodies of water, were preferred foraging habitats for pregnant and lactating Indiana bats, which flew up to 1.5 miles (2.4

km) from upland roosts to forage. They forage between dusk and dawn and feed exclusively on flying insects, primarily moths, beetles, and aquatic insects. Riparian habitat is occupied by Indiana bats from mid-April to mid-September. Romme et al. (1995) cite several studies which document that Indiana bats also forage in upland forests.

Distribution and Habitat. During winter, Indiana bats are restricted to suitable underground habitats known as hibernacula. The majority of hibernacula consist of limestone caves, but abandoned underground mines, railroad tunnels, and even hydroelectric dams can provide winter habitat throughout the species' range (USFWS 2007). Hibernacula with stable or growing populations of Indiana bats have stable low temperatures that allow the bats to maintain a low rate of metabolism and conserve fat reserves through the winter.

Spring emergence occurs when outside temperatures have increased and insects (forage) are more abundant (Richter et al. 1993). Female Indiana bats emerge from hibernation in late March or early April, followed by the males. The period after hibernation but prior to migration is typically referred to as staging. Spring staging occurs when some bats remain close to the cave for a few days before migrating to summer habitats. Others head directly to summer habitat. Most populations leave their hibernacula by late April.

Potential summer habitat occurs throughout much of New York State. At least 39 documented maternity colonies have been identified in Cayuga, Columbia, Dutchess, Essex, Jefferson, Onondaga, Orange, Oswego, and Ulster counties. Male bats disperse throughout the range and roost individually or in small groups. In contrast, reproductive females form larger groups, referred to as maternity colonies, in which they raise their offspring. Non-reproductive females roost individually or in small groups and occasionally are found roosting with reproductive females. Summering Indiana bats (males and females) roost in trees in riparian, bottomland, and upland forests.

Roost trees generally have exfoliating bark which allows the bat to roost between the bark and bole of the tree. Cavities and crevices in trees also may be used for roosting. A variety of tree species are used for roosts including, but not limited to, silver maple (*Acer saccharinum*), sugar maple (*Acer saccharum*), shagbark hickory (*Carya ovata*), shellbark hickory (*Carya laciniosa*), bitternut hickory (*Carya cordiformis*), green ash (*Fraxinus pennsylvanica*), white ash (*Fraxinus americana*), eastern cottonwood (*Populus deltoides*), northern red oak (*Quercus rubra*), post oak (*Quercus stellata*), white oak (*Quercus alba*), shingle oak (*Quercus imbricaria*), slippery elm (*Ulmus rubra*), American elm (*Ulmus americana*), and sassafras (*Sassafras albidum*) (Romme et al. 1995). Structure is probably more important than the species in determining if a tree is a suitable roost site. Tree species which develop loose, exfoliating bark as they age and die are likely to provide roost sites. Exposure of trees to sunlight and location relative to other trees are important to suitability (USFWS 1999).

During the fall breeding season, female bats can number from 50 to 100 individuals in a single tree (NYSDEC 2012b). Maternity colonies use a minimum of 8 to 25 trees per season (Callahan et al. 1997, Kurta et al. 2002). On the average, Indiana bats typically switch roosts every 2 to 3 days with reproductive condition of the female, roost type, weather conditions, and time of year affecting switching behavior (Kurta et al. 2002, Kurta 2005).

Very little research has focused on the use of travel corridors by Indiana bats. Most information pertaining to bat movements and travel corridors is incidental to other portions of a study and general observations. However, Murray and Kurta (2004) showed that Indiana bats increased commuting distance by 55 percent to follow tree-lined paths rather than flying over large agricultural fields, some of which were at least 0.6 miles (1 km) wide. Apparently, suitable forest patches might not be available to Indiana bats unless they are connected by a wooded corridor; however, we do not know the maximum size of an opening Indiana bats can cross. There are numerous observations of Indiana bats crossing interstate highways and open fields. In New York State, Indiana bats tracked from hibernacula to spring and summer roosts have crossed I-81, the Hudson River, I-87, and other highways. These crossings primarily occurred during the initial migration from hibernacula to spring and summer habitats, rather than during nightly foraging bouts.

While little is known about behavior during dispersal, evidence from radio-tracking studies in New York and Pennsylvania indicate that Indiana bats are capable of dispersing at least 30 to 40 miles (48 to 64 km) in one night (Young et al. 2010). It appears as if Indiana bat dispersal from hibernacula to summer habitat is fairly linear and short-term but in the fall is more dispersed and varied. Some studies have shown that Indiana bats travel between 9 and 17 miles (15 and 27 km) from a roost site to a hibernaculum cave where swarming is occurring. In addition, males and females display different dispersal behavior. Females appear to move quickly between the hibernacula and maternal colonies, while males will commonly remain near the hibernacula. While it is unknown, it is likely that Indiana bats dispersing to and from hibernacula follow more meandering routes that may be habitat-related and do not fly at high altitudes, in highly linear paths, or long distances (more than 50 miles [80 km]) non-stop (USFWS 2007).

Threats. The primary threats to Indiana bats in New York State are White-nose Syndrome (WNS), energy development (e.g., wind power), and residential and commercial development that fail to incorporate measures to maintain suitable Indiana bat habitat, and avoid and minimize impacts on maternity colonies and swarming bat populations. Over the long term, from 1965 to 2001, there has been an overall decline in Indiana bat populations and winter habitat modifications have been linked to changes in populations at some of the most important hibernacula. Summer habitat modification is also suspected to have contributed to the decline of bat populations; however, it is difficult to generalize how forest management or disturbance may affect Indiana bats. The *Indiana Bat Draft Recovery Plan* (USFWS 2007) provides a comprehensive summary of Indiana bat life history, which is incorporated by reference.

Northern Long-Eared Bat

Status. In an effort to conserve the northern long-eared bat (*Myotis septentrionalis*), the U.S. Fish and Wildlife Service issued a final rule on January 14, 2016 (81 *Federal Register* 1900) that uses flexibilities under section 4(d) of ESA to tailor protections to areas affected by white-nose syndrome during the bat's most sensitive life stages. The Service listed the northern long-eared bat as threatened under the ESA in April 2015 and established an interim 4(d) rule following drastic population declines caused by white-nose syndrome in the eastern and mid-western United States. The final 4(d) rule for the northern long-eared bat removes prohibitions that would otherwise be in place on "incidental take" of the bat in areas of

the country not affected by white-nose syndrome. There is no designated or proposed critical habitat for this species in New York State. The following description of the northern long-eared bat comes primarily from the following sources, which are incorporated by reference.

- *Revised Biological Assessment for Champlain Hudson Power Express Transmission Line Project (USDOE 2014)*
- *Protections Finalized for Threatened Northern Long-Eared Bats (USFWS 2016)*
- *Programmatic Biological Assessment for Transportation Projects in the Range of the Indiana Bat and Northern Long-Eared Bat (FHWA 2016)*

Behavior and Life History. The northern long-eared bat is medium-sized, averaging between 3 and 3.7 inches (7.62 and 9.4 cm) in length with a wingspan that measures between 9 and 10 inches (23 and 26 cm) (Caceres and Barclay 2000). Females of this species are generally larger and heavier than the males (Caceres and Pybus 1997). As its name suggests, this bat is distinguishable from other *Myotis* species by long ears that extend beyond the tip of its nose when laid forward, a long, narrow, and sharp pointed tragus, and a calcar (cartilage spur at ankle) that lacks a keel (Caceres and Barclay 2000, USFWS 2013b). This species has medium to dark brown fur on its back, dark brown ears and wing membranes.

The diet for the northern long-eared bat is diverse and varied according to season and geographical occurrence. Generally, the diet will consist of moths, flies, leafhoppers, beetles and caddisflies, and spiders. Bats will catch insects by hawking (catching in flight) and gleaning (emitting a high-frequency echolocation call) to find prey (Henderson and Broders 2008). The gleaning call of the northern long-eared bat is the highest frequency of any bat species, and is higher than the hearing frequency of many moth species, thereby giving it a foraging advantage within its feeding habitat. Breeding for this species begins in late summer or early fall when males begin swarming near hibernacula. Following fertilization, pregnant females migrate to summer areas where they roost in small colonies of between 30 and 60 bats, although larger maternity colonies have been observed. Like the Indiana bat, the female northern long-eared bat will nest under the loose dead bark of trees such as shagbark hickory. There is also documentation of this species roosting in manmade structures such as buildings and barns. Females in a maternity colony generally give birth to one pup, and will all give birth at around the same time of year, from late May to late July, depending on where the colony is located within its home range. Young bats begin to fly and explore approximately 4 weeks following birth. Adult northern long-eared bats live up to 19 years (USFWS 2013b).

Distribution and Habitat. The range of this species includes much of the eastern and north central United States, and all Canadian provinces for the Atlantic Ocean west to the southern Yukon Territory and eastern British Columbia (USFWS 2013b). This species has been observed year-round throughout New York State (USFWS 2013f).

Habitat use changes over the course of the year and varies based on sex and reproductive status. Reproductive females often use different summer habitat than males and non-reproductive females. Generally, summer and winter ranges for this species will be identical, but the habitat types used within those ranges will differ. Potential summer habitat occurs throughout much of New York State. Maternity colonies are formed in roost trees and are more widely distributed and numerous than are major

hibernacula. Northern long-eared bats overwinter in multi-species hibernacula that are typically caves or abandoned underground mine shafts with deep crevices (Caceres and Pybus 1997, Caceres and Barclay 2000). In these hibernacula, this species will usually comprise less than 25 percent of the total number of individuals (Caceres and Pybus 1997). Northern long-eared bats have been observed in 58 hibernacula in mines, caves, and tunnels in New York.

Edge habitat is important for northern long-eared bats as they migrate and forage (WDNR 2013). Bats will migrate from hibernacula to summer roosts, or fly from their roosts to feeding grounds following the habitat edges to maintain protection from wind and predation. Additional to the protection that edge habitat provides, this behavior may also allow bats more feeding opportunities because food is more abundant around edge habitat. Commuting along edge habitat may assist the bats with navigation and orientation through use of linear edges as landmarks.

Threats. Most mortality in this species occurs during the juvenile stage (Cyceres and Pybus 1997). The predominant threat affecting population declines of this species is WNS, an emerging infectious fungal disease that depletes fat stores, reduces responsiveness to human disturbance, and results in a lack of immune response during hibernation and uncharacteristic dispersing from hibernacula during the day in mid-winter (WNS Session 2008). As indicated for the Indiana bat, northern long-eared bat populations are declining with the destruction and modification of their summer and winter habitats. Access to hibernacula may be restricted by doors or gates intended to exclude humans. Also, the thermal regime typical of these habitats may be adversely altered by mining activities, or hibernacula in mines may be destroyed altogether with mine passage collapses. Additionally, habitats are subject to adverse impacts from development activities (industrial, commercial, and residential) on overwintering, roosting, and feeding bats.

In December 2017, a site investigation was performed by an ecologist who is also a certified arborist. Based on the results of the investigation, it was identified that no trees along the shoreline or within the area of disturbance had the potential to serve as bat roosting habitat. It was observed that in close proximity to the site, there are large swathes of woodlands and within the site, there are abandoned concrete structures and voids, which would not be disturbed as part of the dredging, that would likely serve as attractive bat roosting habitat.

Peregrine Falcon

Status. As indicated in the letter from the New York Natural Heritage Program dated November 21, 2017, the peregrine falcon (*Falco peregrinus*) is listed as endangered in New York State; it is not listed as endangered or threatened in the ESA. The following description of the peregrine falcon comes primarily from the following sources, which are incorporated by reference.

- *Peregrine Falcon Fact Sheet* (NYSDEC 2017)
- *Falcons Nesting on the Mid-Hudson Bridge* (NYSBA 2017)

Behavior and Life History. Peregrine falcons generally return to the same nesting territory annually and mate for life. The courtship flight is a spectacular sight. The pair climbs high in the air and performs a

precise acrobatic act of whirling spirals and steep rapid dives, often touching in midair. The average clutch consists of three to four eggs which hatch after an incubation period of 29-32 days. The single brood fledges after 35-42 days. Both parents participate in incubation and brooding activities, but the female remains at the nest for the majority of the time while the male hunts and brings food to her and the young. Young falcons may stay in the area for about six weeks after they fledge, developing their flying and hunting skills. Sexual maturity is generally reached at two years of age, but one-year-olds have been known to produce young. Individuals may live as long as 20 years.

Behavior and Distribution: At one time, there were approximately 350 breeding pairs in the eastern U. S., including 40-50 historic eyries (nest sites) in New York. By 1965, all were gone and populations in other parts of the country showed similar declines. Release programs initiated by the Peregrine Fund in the mid 1970's have resulted in peregrine falcons breeding in New York once again. In 1998, 38 pairs were present in New York, 36 bred, 31 were successful and 69 young fledged. New urban nests have been reported upstate for the first time in Albany. Gradual increases in the breeding population have been recorded throughout the east.

Peregrine falcons nest in a nest box on the Mid-Hudson Bridge, which carries State Routes 44 and 55 over the Hudson River, between Poughkeepsie and Highland, NY. The bridge is about 0.5 miles south of the site. The first nest box on the Mid-Hudson Bridge was put up in the late 80's by "Project Soar" through a program sponsored by the Museum of the Hudson Highlands. However, it was not until 1996 that peregrine falcons nested on the Mid-Hudson Bridge. Since then, falcons have nested on the Mid-Hudson Bridge every year, except 2001.

Threats. Like many other birds of prey, peregrine falcons have suffered from the use of pesticides. Exposure to DDT and other chemical contaminants has caused population declines since the 1940's. These pesticides cause eggshell thinning which drastically lowers breeding success. Laws banning the use of DDT were passed by New York State in 1971 and by the federal government in 1972. Although DDT contamination has been reduced in this country, it continues to affect the peregrine and its prey.

5. Environmental Baseline Conditions

5.1 Hudson River

The Hudson River is 315 miles (507 km) long from its source at Lake Tear of the Clouds in the Adirondacks to the mouth at the Battery in New York City. The Hudson River is tidal for 153 miles (246 km) from the mouth to the Federal Dam at Troy. Salt water travels about 60 miles (97 km) up the river to Newburgh, New York.

The site is located on the Hudson River approximately 83 river miles (RM) north of New York Harbor, and 75 RM below the Federal Dam in Troy. The Hudson River is tidal below the Federal Dam. The extent of the salt wedge (100 milligrams per liter of chloride) occurs in the southern part of the Hudson River and may reach as far north as Poughkeepsie during very dry years (USGS, 2017). Water temperature taken at a location 3.5 mi south of the Mid-Hudson Bridge indicated the highest temperature after October 1, 2007 was 28.6 °C; the lowest water temperature after that date was -0.2 °C, Feb. 6, 7, 2010.

5.1.1 Deepwater Habitat

Deepwater areas provide habitat for a diversity of marine species in the Hudson River. The Kingston-Poughkeepsie Deepwater Habitat is designated by the NYSDOS as a Significant Coastal Fish and Wildlife Habitat (SCFWH). This SCFWH is an extensive section of deepwater habitat in the Hudson River. It is an approximately 6,350 acre habitat that encompasses a 25 mile stretch of the Hudson River extending approximately from Kingston Point in the City of Kingston in Ulster County and the Village of Rhinecliff in Dutchess County to just south of Wappinger Creek in the Town of Wappinger in Dutchess County. This SCFWH area is located 200 feet offshore of the site.

Deepwater areas support a diversity of freshwater and migratory species in the Hudson River. Fish species found in this section of river include fourspine stickleback (*Apeltes quadracus*), hogchoker (*Trinectes maculatus*), killifish (*Fundulus diaphanous*), threespine stickleback (*Gasterosteus aculeatus*), white perch (*Morone americana*), bluegill (*Lepomis macrochirus*), brown bullhead (*Ameiurus nebulosus*), common carp (*Cyprinus carpio*), golden shiner (*Notemigonus crysoleucas*), largemouth bass (*Micropterus salmoides*), pumpkinseed (*Lepomis gibbosus*), smallmouth bass (*Micropterus dolomieu*), spottail shiner (*Notropis hudsonius*), white catfish (*Ameiurus catus*), yellow perch (*Perca flavescens*), alewife (*Alosa pseudoharengus*), American eel (*Anguilla rostrata*), American shad (*Alosa sapidissima*), blueback herring (*Alosa aestivalis*), and striped bass (*Morone saxatilis*).

Poughkeepsie is believed to be the northernmost wintering location of shortnose sturgeon in the Hudson River. Recent fisheries investigations of the Hudson River indicate spawning as well as wintering of sturgeon in this area. Habitat requirements of this species in the Hudson River are not well known. Shortnose sturgeon use the portion of the river which generally is greater than 30 feet in depth. This area is also significant since it is largely responsible for the abundance of marine species upriver (the northern range limit for many in New York), especially during periods of low freshwater flows (summer). During the spring spawning run of shad, commercial drift netting takes place in the surface waters overlying this area (NYSDOS 2012a).

5.1.2 Benthic Habitat

Benthic community structure and population density are dependent on factors including water quality, sediment type, the presence or absence of submerged aquatic vegetation (SAV), and human alterations. Benthic communities vary in distribution in the Hudson River depending on bottom type (i.e., hard or soft substrate), salinity, SAV, and location along the river. As described in Chapter 4, the benthic community appeared to consist mainly of silts with some detrital material. Many of the areas show the deleterious effects of NAPL and the invasive zebra mussel appears to be abundant in most locations. This evidence would suggest the benthic habitat in the dredged prisms is of lower ecological value.

As shown in Table 4-2, the sediments in the dredge areas mostly consist of silts, with some gravel and wood detritus.

5.1.3 Submerged Aquatic Vegetation

SAV is plants that are always under water. The most common native species of SAV in the Hudson River watershed is water celery (*Vallisneria americana*). SAV provides important habitat for juvenile fish that can hide within the leaves. Many tidal marshes and vegetated areas of the Hudson River are key nurseries for young fish, which may be more subject to predation in the open river. In addition to fish, SAV beds provide habitat for macroinvertebrates, and food for waterfowl, either by eating the plants themselves or eating the animals living in the plant beds. SAV is an important source of oxygen in the water, which aquatic animals need to survive and is used as a key measure of water quality.

The location and amount of SAV beds can change year to year, with one of the most drastic observations occurring in the summer of 2012. Water celery was not found in areas where it was consistently observed in previous years. One possible cause for this decline is that the sediment pulse from Hurricane Irene and Tropical Storm Lee may have inhibited SAV growth by burying stems and blocking light when the paired storms came through the Hudson Valley in the late summer of 2011. The Hudson River Estuary submerged aquatic vegetation survey conducted in 2014 indicated that SAV was not present near the site (NYSDEC 2014).

6. Potential Effects on Federally Listed Aquatic Species

As discussed in Section 1, the USACE has the responsibility under the ESA to determine whether or not the NWS MGP Remediation Project would adversely affect federally listed endangered and threatened species and species proposed for listing and their designated or proposed designated critical habitat.

Potential impacts on ESA-listed species could occur during proposed CHGE dredging and capping activities. As noted in Section 3, there is designated critical habitat for the Atlantic sturgeon in the NWS MGP Remediation Project area. Proposed measures to reduce potentially adverse impacts on ESA-listed species during dredging and capping will be included in the project; these are described in Section 7.2. The determination of effects are discussed in Section 7. Section 8 presents a cumulative effects analysis of the NWS MGP Remediation Project combined with other reasonably foreseeable actions on protected species.

Table 4 presents a summary of the impacts on aquatic protected species, which are discussed in detail in this section.

6.1 Shortnose Sturgeon and Atlantic Sturgeon

Based on the analysis in this section, it has been concluded that any effects on the shortnose sturgeon and Atlantic sturgeon would be insignificant or discountable, and that the NWS MGP Remediation Project may affect, but is not likely to adversely affect, those species (see Table 5).

Table 4

Summary of Impacts on Federally Listed Species by Resource Area

Resource Area	Description of Impacts
Sediment	Localized temporary disturbance to approximately 7.5 acres of river bottom by dredging in the Hudson River, resulting in habitat degradation, avoidance, or loss. Along the shoreline and over the underwater utility crossings where dredging is not feasible, impacted material containment will be provided through capping. The cap will be placed along the entirety of the affected riverbank slope (approximately 1.2 acres) and over portions of the underwater utility crossings (approximately 1.1 acres).
Turbidity	Targeted river sediments will be dredged using an environmental bucket, which is designed to provide flat dredge cuts for maximum control of the dredged surface and seals around the bucket to limit loss of material as the bucket is raised through the water column. All dredging will take place within a containment cell outfitted with turbidity curtains and floating booms on all sides to control any turbidity generated during dredging. Water quality (turbidity) will be monitored for the duration of the dredging by means of three buoy-mounted remote sensing stations that will be moored around the perimeter of the work area to confirm that the containment cell is functioning properly.
Benthic communities	Dredged areas deeper than 2 feet below the existing bathymetry will be backfilled after dredging with certified clean sand to 2 feet below the existing bathymetry. The capped dredged areas will be allowed to reestablish the original (pre-dredging) bathymetry by natural sediment transport processes.
SAV	SAV does not exist in the Hudson River adjacent to the site.
SCFWH	<p>In the Hudson River adjacent to the project site is the Kingston – Poughkeepsie Deepwater Significant Coastal Fish and Wildlife Habitat area (SCFWH). Dredging of the contaminated sediment is anticipated to be conducted from October 2018 to February 2019. Dredging in the SCFWH area of approximately 20,000 cubic yards within approximately 4 acres will be conducted using an environmental bucket within a containment cell which will be outfitted with turbidity curtains that extend to the river bottom and floating booms on all sides to control turbidity beyond the dredging area.</p> <p>As part of the coastal zone consistency determination, a Habitat Impairment Test was performed, The HIT determined that although there would be a minor short-term disruption to a small area within the SCFWH, overall, the long term benefits would be positive due to the removal of NAPL-laden sediments.</p>
Vessel Strikes	Construction vessels proposed for use during dredging and capping operations would have relatively shallow drafts. Sturgeon are generally found within 3.3 feet (1.0 meter) of the bottom in the deepest available water. Therefore, the chance of vessel-related mortalities to sturgeon are expected to be negligible.

Table 5

Determination of Effect under the ESA for Federally Listed Aquatic Species in the NWS MGP Remediation Project Area

Common Name	Scientific Name	ESA Status	Determination of Effect
Shortnose sturgeon	<i>Acipenser brevirostrum</i>	T	May affect, but not likely to adversely affect
Atlantic sturgeon	<i>Acipenser oxyrinchus</i>	T ¹ , E ^{2,3,4,5}	May affect, but not likely to adversely affect

Table Key: E = Federally listed as endangered; T = Federally listed as threatened.

Notes:

1. Gulf of Maine DPS.
2. New York Bight DPS.
3. Chesapeake Bay DPS.
4. Carolina DPS.
5. South Atlantic DPS.

6.2 Impacts on Sturgeon Prey

Sediment disturbances from dredging approximately 7.9 acres and capping of approximately 4.2 acres of the dredged areas would result in a short-term loss of benthic organisms and shellfish that serve as forage for Atlantic and shortnose sturgeon. The impacts from these activities would be short term.

Because the habitat disturbance would affect a relatively small amount of the river bottom and because of the temporary nature of the disturbance, the remediation activities in the Hudson River are expected to result in negligible reductions in benthic shellfish and infaunal organisms that serve as prey for shortnose and Atlantic sturgeon. There will be an ecological benefit to the water column and benthic habitat in the dredging area due to the removal of the sediment contaminated by the operation of the former MGP facility. As such, impacts on benthic resources which serve as sturgeon prey from sediment disturbance are expected to be insignificant.

7. Remediation Activities in the Hudson River

Construction Window: As described below, sediment disturbance, temporary increases in turbidity and associated water quality degradation, sediment redeposition, and vessel strikes would have an insignificant effect on shortnose and Atlantic sturgeon. Construction windows were determined based upon the information provided by GARFO (2017) when the shortnose and Atlantic sturgeon use the Hudson River. Tables 1 and 3 illustrate the life history stages (spawning, rearing, and overwintering) of shortnose and Atlantic sturgeon and the period of the year when these life stages are present. The proposed dredging at the site are anticipated to be conducted between October 2018 and February 2019 and would avoid the life history stages of the shortnose and Atlantic sturgeon in the Hudson River at the site. Additionally, the less intrusive capping of the underwater utility crossing areas and the river slope is anticipated to be conducted between July 2019 and September 2019, after the published key migratory spawning season (March 1 and June 30).

Articulated Capping System: The slope of the shoreline along the bulkhead cannot be dredged due to the shallow depth of the water and stability issues with the slope. A sheetpile bulkhead wall will be installed as part of the bulkhead remediation activities. To isolate the impacted sediment remaining beyond the sheetpile bulkhead wall from the river, approximately 1.2 acres of articulated capping system consisting of RCM with grout filled molds will be installed along the river slope (Appendix A).

Concrete Mats: Since dredging cannot be conducted in the area of the existing underwater gas electric, and fiber optic lines that extend across the Hudson River, an approximately one acre area near and over the utility crossings will be capped with a cover system consisting of RCM overlain by armored concrete blocks to isolate the impacted sediment in these areas. Placement of concrete mats would bury the existing benthic community (if present), including potential prey for Atlantic and shortnose sturgeon. Although individuals among the existing benthic communities might be impacted, installation of the concrete mats would not preclude the survival of benthic infaunal species and shellfish. Shortnose and Atlantic sturgeon would be able to use adjacent areas for foraging and other activities. Installation of these materials could cause a permanent change in benthic habitat from soft sediments to the hard substrate of the concrete mats within the footprint of the concrete mats. Concrete mats provide hard substrate habitat, and gaps in the mats provide velocity refuge and cover for aquatic invertebrates and small fishes (Fischenich 2003), possibly including benthic prey for shortnose and Atlantic sturgeon. Where concrete mats would be installed, habitat could be permanently altered, but the area requiring concrete mats is very small relative to the available habitat for shortnose and Atlantic sturgeon. When the concrete mats are placed in areas of fine sediment, the spaces between the individual concrete elements would be filled by suspended sediment and the surficial habitat would be partially restored. It is likely that some sediment would accumulate on the concrete mats, resulting in some benthic habitat re-colonization. New and functional communities would be expected to recolonize these areas over time.

Best Management Practices: To minimize impacts to Hudson River during the implementation of the remedial activities, water-based best management practices (BMPs) will be implemented prior to the start of work. The BMPs are typical of the types of controls successfully used at other environmental remediation projects to minimize impacts to riverine systems. BMPs and engineering controls including the containment cell will be installed prior to the start of the dredging and will be used throughout the

dredging. Additionally, dredged areas will be backfilled with clean sand imported from upland sources and transported to the site via barge. Dredged material will be dewatered at the site and shipped off-site for treatment and disposal.

Water-based control measures will include performing the dredging, backfilling, and capping work within containment (i.e., turbidity curtain), and implementing surface water and water column monitoring activities. These BMPs will monitor, control and isolate potential sediment, NAPL and sheen releases to the river thereby reducing turbidity and oxygen demands and protecting against siltation.

Turbidity Curtains: Prior to the dredging of NAPL impacted sediments, a turbidity curtain will be installed around the perimeter of the dredge areas. Absorbent booms will be installed in sediment dredging areas to contain the migration of any NAPL sheens that may be encountered during sediment removal activities. The turbidity curtain system will be inspected and maintained through the duration of sediment dredging activities.

Shortnose and Atlantic sturgeon are found in turbid waters (Dadswell et al. 1984) and feed on benthic invertebrates and are, therefore, tolerant of suspended sediment at the levels that are temporarily generated by marine construction activities (NMFS 2013a). NMFS concluded that the effect of suspended sediment concentrations in the range of 10 to 350 mg/L from construction activities for a marina project in the Haverstraw Bay region would not be significant to shortnose sturgeon. It is anticipated that the impact of suspended sediment would be similarly insignificant for the closely related Atlantic sturgeon. Citing the literature, NMFS indicated that the concentrations of total suspended sediments that would be expected to show adverse impacts on fish would be 580.0 mg/L for the most sensitive species, with 1,000 mg/L being more typical (FHWA 2012).

Water Quality Monitoring: Visual surface water monitoring will occur throughout the dredging and backfilling operation. Oil absorbent booms and/or pads will be used around all platforms and turbidity curtain to prevent migration of sheens outside of dredge areas. If NAPL/sheens are observed outside the turbidity curtain, the sheen will be chased and absorbed using absorbent booms and/or pads. The primary controls (turbidity curtains) and sorbent booms next to curtains will be inspected and corrected as necessary to ensure their effectiveness in capturing sediments and NAPL/sheens.

Turbidity Monitoring: A turbidity monitoring program will be performed during the sediment removal and restoration activities. Water quality (turbidity) will be monitored for the duration of the dredging by means of three buoy-mounted remote sensing stations that will be moored around the perimeter of the work area to confirm that the containment cell is functioning properly. Turbidity will be measured at an upstream location, a location near the work zone, and a downstream location within Hudson River.

Inspections of the water-based controls will be conducted each day at the beginning of removal activities. Inspections will also be conducted, as appropriate, in response to visible sediment plumes migrating from the work area or measured turbidity levels above the action level of 50 nephelometric turbidity units (NTUs) above the turbidity level at the upstream monitoring location. Inspections in response to turbidity levels above the action level metric will begin with a surface inspection using a boat. If the reason for the turbidity exceedance cannot be determined through surface inspection, a hand-held turbidity meter or

other appropriate method will be used to identify the source. The Construction Quality Assurance Plan (CQAP) will identify contingency measures to meet turbidity action levels. Contingency measures may include modification to dredge operations (e.g., fall height, cycle time, bucket handling procedures, use of a rinse tank, etc.) or modifications or repairs of the containment systems.

Vessel Strikes: The vessels used during the dredging will include a barge-mounted crane that will conduct the dredging using an environmental bucket. Once this barge is located within the containment cell, the crane barge will be only moved when necessary to complete the dredging within the containment cell. Adjacent to the crane barge and outside of the containment cell will be a dredged material barge. The dredge crane will place the dredged material in this barge. When the barge is filled, it will be moved by a tug boat the short distance to the shoreline to remove the standing water for treatment on the upland of the site. After the water has been treated, it will be discharged in accordance with the SPDES Permit Equivalency. The dredged material and the solids will be transported to an offsite facility via barge where the material will be stabilized and disposed at an approved disposal facility.

Based on the types of vessels to be employed and their relatively shallow draft, there should always be sufficient clearance between vessels and the river bottom. The typical draft of the barges is approximately 12 feet (4 meters). Additionally, reduced vessel speeds in the dredging area (less than 4 knots) would help to avoid vessel strikes for sturgeon near the surface. As such, the possibility of a vessel striking shortnose or Atlantic sturgeon during dredging or capping is discountable.

8. Conclusions

8.1 Effects Determination for Listed Species

Based on the description of the NWS MGP Remediation Project in Section 2 of this BA and further described in the status of species and environmental baseline described in Sections 3 and 4, and the analysis of potential impacts in Section 5, it is concluded that:

The NWS MGP Remediation Project may affect, but is unlikely to adversely affect, the shortnose sturgeon or any DPS of Atlantic sturgeon. Sediment disturbance, temporary increases in turbidity and associated water quality degradation, sediment redeposition, noise and vibration, vessel strikes, and accidental releases of hazardous materials are not expected to have significant effects on shortnose sturgeon and Atlantic sturgeon. Conservation measures such as establishment of construction windows to avoid seasonal periods where sensitive species are using these portions of the rivers would avoid, or minimize to insignificant levels, adverse effects on federally listed sturgeon species. .

8.2 Effects Determination for Critical Habitat

On August 17, 2017, critical habitat was designated for the Endangered New York Bight, Chesapeake Bay, Carolina and South Atlantic Distinct Population Segments of Atlantic Sturgeon and the Threatened Gulf of Maine Distinct Population Segment of Atlantic Sturgeon (82 *Federal Register* 39160). This Final Rule became effective September 18, 2017. Critical habitat has been designated for the Atlantic sturgeon in the Hudson River from the southern end of Manhattan, NY to the Troy Lock and Dam in Rensselaer County, NY. The proposed dredging of approximately 7.6 acres would have a temporary adverse impact on Atlantic sturgeon foraging habitat.

According to the GARFO Master Species Table for Atlantic sturgeon (Table 3), utilization of the Hudson River for spawning takes place well north of the site in late spring to summer. During rearing in late spring to summer, Atlantic sturgeon eggs, larvae, juveniles and young-of-year occupy the Hudson River at different life stages from the Tappan Zee Bridge north to Kingston. However during the winter when the proposed dredging would take place, rearing does not occur. According to GARFO, foraging takes place in tidally influenced flats and the lower Hudson River in the summer. Overwintering adults use the lower Hudson River during the winter while juveniles use the river between RKM 19 (Yonkers) to RKM 75 south of Poughkeepsie and the site.

Based upon the data provided in the GARFO Master Species Table for Atlantic sturgeon, the proposed dredging and capping project may affect, but is not likely to adversely affect designated Atlantic sturgeon critical habitat in the Hudson River.

9. References

- ASA 2012 ASA Analysis & Communication, Inc. (ASA). 2014. 2012 Year Class Report for the Hudson River Estuary Monitoring Program. Prepared for Dynege Roseton LLC, Entergy Nuclear Indian Point 2 LLC, Entergy Nuclear Indian Point 3 LLC, ASMFC and Mirant Bowline LLC.
- ASA 2013 ASA. 2013. 2011 Year Class Report for the Hudson River Estuary Monitoring Program. Prepared for Dynege Roseton L.L.C., Entergy Nuclear Indian Point 2 LLC, Entergy Nuclear Indian Point 3 LLC., and Mirant Bowline LLC.
- ASMFC 2008 Atlantic States Marine Fisheries Commission (ASMFC). 2008. *A Cooperative State-Federal Program for Conservation of Atlantic Coastal Fisheries – Hudson River Atlantic Sturgeon Tagging Study*. Final Report for Grant Number A05NMF4741276. Prepared by the Hudson River Fisheries Unit, NYSDEC, New Paltz, New York.
- ASMFC. 2017. Habitat Addendum IV to Amendment 1 of the Interstate Fisheries Management Plan for Atlantic Sturgeon. Available online: http://www.asmfc.org/uploads/file/sturgeonHabitatAddendumIV_Sept2012.pdf. Accessed 28 November 2017.
- ASSRT 2007 Atlantic Sturgeon Status Review Team (ASSRT). 2007. Status Review of Atlantic Sturgeon (*Acipenser oxyrinchus oxyrinchus*). National Marine Fisheries Service, Silver Spring, Maryland.
- Bain 1997 Bain, M.B. 1997. Atlantic and shortnose sturgeons of the Hudson River: Common and divergent life history attributes. *Environmental Biology of Fishes* 48: 347-358.
- Bain et al. 2000 Bain, M.B., N. Haley, D. Peterson, J.R. Waldman, and K. Arend. 2000. Harvest and habitats of Atlantic sturgeon *Acipenser oxyrinchus* Mitchell, 1815, in the Hudson River estuary: Lessons for sturgeon conservation. *Boletín-Instituto Español de Oceanografía* 16: 43-53.
- Basov 1999 Basov, B.M. 1999. "Behavior of Sterlet Sturgeon (*Acipenser ruthenus*) and Russian Sturgeon (*A. gueldenstaedtii*) in Low-Frequency Electric Fields." *Journal of Ichthyology*. 39:782-787.
- Bell et al. 2006 Bell, R.E., R.D. Flood, S. Carbotte, W.B.F. Ryan, C. McHugh, M. Cormier, R. Versteeg, H. Bokuniewicz, Y.L. Ferrini, J. Thissen, J.W. Ladd, and E.A. Blair. 2006. "Benthic Habitat Mapping in the Hudson River Estuary." Pages 51–64 in J. S. Levinton and J. R. Waldman, ed. *The Hudson River Estuary*. New York: Cambridge University Press.
- Berry, W., N. Rubinstein, B. Melzian, and B. Hill. 2003. *The Biological Effects of Suspended and Bedded Sediment (SABS) in Aquatic Systems: A Review*. Internal Report of the United States Environmental Protection Agency.
- Callahan 1993 Callahan, E.V. 1993. Indiana bat summer habitat requirements. M.S. Thesis. University of Missouri, Columbia. 84 pp.
- Callahan, E.V., R.D. Drobney, and R.L. Clawson. 1997. Selection of summer roosting sites by Indiana bats (*Myotis sodalis*) in Missouri. *Journal of Mammalogy* 78: 818-825.
- Caceres, M.C. and R. Barclay. 2000. *Myotis septentrionalis*. *Mammalian Species*, 634: 1-4.

Caceres, M.C. and M.J. Pybus. 1997. Status of the Northern Long-Eared Bat (*Myotis septentrionalis*) in Alberta. Available online: <<http://srd.alberta.ca/FishWildlife/SpeciesAtRisk/SpeciesAtRiskPublicationsWebResources/Mammals/documents/SARStatusNorthernLongEaredBatAlberta-1997.pdf>>. Accessed 29 October 2013.

Carter, A., E. Hague, and L. Floyd. 2008. Benthic Infauna Recovery Following Channel Dredging in the Vicinity of Bogue Inlet, North Carolina. In *Proceedings of the 2008 National Conference on Beach Preservation Technology*. February 2008.

Carter, A., E. Hague, L. Floyd. 2008. "Benthic Infauna Recovery Following Channel Dredging in the Vicinity of Bogue Inlet, North Carolina." In *Proceedings of the 2008 National Conference on Beach Preservation Technology*. February 2008.

Clarke, D.G., and D.H. Wilber. 2000. *Assessment of Potential Impacts of Dredging Operations due to Sediment Resuspension*. DOER Technical Notes Collection (ERDC TN-DOER-E9). US Army Engineer Research and Development Center, Vicksburg, Mississippi.

Coch, N. K. 1986. "Sediment Characteristics and Facies Distributions." *Northeastern Geology* 8 (3): 109–129.

Dadswell, M.J., B.D. Taubert, T.S. Squiers, D. Marchette, and J. Buckley. 1984. Synopsis of Biological Data on Shortnose Sturgeon, *Acipenser brevirostrum* LeSueur 1818. NOAA Technical Report NMFS/S 140. National Marine Fisheries Service, Silver Spring, Maryland.

Dovel, W. L. and T. J. Berggren. 1983. "Atlantic Sturgeon of the Hudson River Estuary, New York." *New York Fish and Game Journal* 30:140–172.

Dovel, W.L., A.W. Pekovitch, and T.J. Berggren. 1992. Biology of the shortnose sturgeon (*Acipenser brevirostrum* Lesueur 1818) in the Hudson River Estuary, New York. Pages 187-216 in C.L. Smith (ed). *Estuarine Research in the 1980s*. State University of New York Press, Albany, New York.

ESS Group, Inc. 2011. Concrete Mattress Macroinvertebrate and Video Census Monitoring Report. Long Island Replacement Cable (LIRC) Project. Prepared for Northeast Utilities Services Company as agent for the CT Light & Power Company, Berlin, Connecticut by ESS Group, Inc., Wellesley, Massachusetts.

Federal Highway Administration (FHWA). 2012. "Biological Assessment for the Tappan Zee Hudson River Crossing Project." Available online: <http://www.tzsite.com/tzbsite_2/deis_2.html>. Accessed 14 November 2017.

Findlay, S, C. Wigand, and W.C. Nieder. 2006. "Submersed Macrophyte Distribution and Function in the Tidal Freshwater Hudson River." Pages 230–241 in J. S. Levinton and J. R. Waldman, ed., *The Hudson River Estuary*. New York: Cambridge University Press.

Fischenich, J.C. 2003. *Effects of Riprap on Riverine and Riparian Ecosystems*. ERDC/EL TR-03-4. U.S. Army Engineer Research and Development Center, Vicksburg, Mississippi.

Gardner, J.E., J.D. Garner, and J.E. Hoffman. 1991. Summer Roost Selection and Roosting Behavior of *Myotis sodalis* (Indiana bat) in Illinois. Illinois Natural History Survey, Bloomington, Illinois.

Geoghegan, P., M.T. Mattson, and R.G. Keppel. 1992. Distribution of the shortnose sturgeon in the Hudson River estuary, 1984-1988. Pages 217-241 in C.L. Smith (ed). *Estuarine Research in the 1980s*. State University of New York Press, Albany, New York.

Germano, J.D., and Cary, D. 2005. Rates and effects of sedimentation in the context of dredging and dredged material placement. *DOER Technical Notes Collection*. March 2005.

Gilbert, C.R. 1989. *Species profiles: Life Histories and Environmental Requirements of Coastal Fishes and Invertebrates (Mid-Atlantic Bight) – Atlantic and Shortnose Sturgeons*. USFWS Biological Report 82(11.122) and USACE Technical Report EL82-4. 28 pp. December 1989.

Greater Atlantic Regional Fisheries Office (GARFO) Master ESA Species Table – Atlantic Sturgeon (NMFS Web site
(https://www.greateratlantic.fisheries.noaa.gov/protected/section7/listing/garfo_master_esa_species_table_-_atlantic_sturgeon_051917.pdf) Accessed December 8, 2017

Greater Atlantic Regional Fisheries Office (GARFO) Master ESA Species Table - Shortnose Sturgeon (NMFS Web site
(https://www.greateratlantic.fisheries.noaa.gov/protected/section7/listing/garfo_master_esa_species_table_-_shortnose_sturgeon_may2017.pdf) Accessed December 8, 2017.

Greene, K.E., J.L. Zimmerman, R.W. Laney, and J.C. Thomas-Blate. 2009. *Atlantic Coast Diadromous Fish Habitat: A Review of Utilization, Threats, Recommendations for Conservation, and Research Needs*. Atlantic States Marine Fisheries Commission Habitat Management Series No. 9, Washington, D.C.

Henderson, L.E. and H.G. Broders. 2008. Movements and Resource Selection of the Northern Long-Eared Myotis (*Myotis septentrionalis*) in a Forest–Agriculture Landscape. *Journal of Mammalogy*, 89(4): 952-963.

Hirsch, N.D., L.H. DiSalvo, and R. Peddicord. 1978. “Effects of dredging and disposal on aquatic organisms.” Technical Report DS-78-5. U.S. Army Engineer Waterways Experiment Station, Vicksburg, MS. NTIS No. AD A058 989.

Kahnle, A.W., K.A. Hattala, K.A. McKown, C.A. Shirey, M.R. Collins, T.S. Squiers, Jr., and T. Savoy. 1998. Atlantic States Marine Fisheries Commission Atlantic Sturgeon Stock Assessment. Peer Review Report.

Kurta, A. 2005. Roosting ecology and behavior of Indiana bats (*Myotis sodalis*) in summer. Pages 29-42 in K.C. Vories and A. Harrington (eds). *The Indiana Bat and Coal Mining: A Technical Interactive Forum*. Office of Surface Mining, U.S. Department of the Interior, Alton, Illinois.

LaSalle, M.W., D.G. Clarke, J. Homziak, J.D. Lunz, and T.J. Fredette. 1991. “A framework for assessing the need for seasonal restrictions on dredging and disposal operations.” Department of the Army, Environmental laboratory, Waterways Experiment Station, Corps of Engineers, Vicksburg, Mississippi.

Murray, S.W., and A. Kurta. 2004. Nocturnal activity of the endangered Indiana bat (*Myotis sodalis*). *Journal of Zoology* 262: 197-206.

NatureServe. 2017. “NatureServe Explorer: An Online Encyclopedia of Life” Available online: <<http://www.natureserve.org/explorer>>. Accessed 21 November 2017.

- Nepf, H.M. and W.R. Geyer. 1996. "Intratidal variation in stratification and mixing in the Hudson estuary." *Journal of Geophysical Research*. 101(C5): 12,079-12,086.
- Newell, R.C., L.J. Seiderer, N.M. Simpson, and J.E. Robinson. 2004. "Impacts of Marine Aggregate Dredging on Benthic Macrofauna off the South Coast of the United Kingdom." *Journal of Coastal Research*. 20(1): 115–125.
- National Marine Fisheries Service (NMFS). 1998. Final Recovery Plan for the Shortnose Sturgeon (*Acipenser brevirostrum*). NMFS, Silver Spring, Maryland. NMFS 2011a NMFS. 2011. *Biological Opinion on the Issuance of a Permit to Evaluate Shortnose Sturgeon Populations in the Hudson River (Number 16439) Pursuant to Section 10 (a)(1) of the Endangered Species Act of 1973*. 21 November 2011.
- NMFS 2011b NMFS. 2011. *Vessel Strikes Working Group Discussion, NMFS Sturgeon Workshop, Alexandria, VA*. National Marine Fisheries Service, Silver Spring, Maryland. 11 February 2011.
- NMFS 2013a NMFS. 2013. *Biological Opinion for the Tappan Zee Bridge Replacement (F/NER/2013/05769)*. 10 April 2013.
- NMFS. 2013. *Biological Opinion for Continued Operations of Indian Point Nuclear Generating Unit Nos. 2 and 3*. 30 January 2013.
- National Oceanic and Atmospheric Administration (NOAA) Office of Protected Resources. 2013. Species Profile: Shortnose Sturgeon: *Acipenser brevirostrum*. Available online: <<http://www.nmfs.noaa.gov/pr/species/fish/atlanticsturgeon.htm>>. Accessed 24 November 2017.
- New York Natural Heritage Program (NYNHP). 2017. "Shortnose Sturgeon Fact Sheet." Available online: <<http://acris.nynhp.org/report.php?id=7168>>. Accessed 24 November 2017.
- NYNHP. 2017. "Indiana Bat Factsheet." Available online: <<http://www.acris.nynhp.org/report.php?id=7405>>. Accessed 24 November 2017.
- NYSBA. 2017. "Falcons Nesting on the Mid-Hudson Bridge." Available online: <<http://www.nysba.state.ny.us/.../Peregrine%20Falcons%20Hatch%20on%20Mid-Hudson%2>>. Accessed 11 December 2017.
- NYSDEC. 2017. "Shortnose Sturgeon Fact Sheet." Available online: <<http://www.dec.ny.gov/animals/26012.html>>. Accessed 29 November 2017.
- NYSDEC. 2017. "Dwarf Wedgemussel Fact Sheet." Available online: <<http://www.dec.ny.gov/animals/42253.html>>. Accessed 29 November 2017.
- NYSDEC. 2017. "Peregrine Falcon Fact Sheet" Available online: <<http://www.dec.ny.gov/animals/34268.html>>. Accessed 11 December 2017.
- NYSDEC. 2017. "Submerged Aquatic Vegetation Habitat." Available online: <<http://www.dec.ny.gov/lands/87648.html>>. Accessed 30 November 2017.

NYSDOS. 2017. "Significant Coastal Fish & Wildlife Habitats." Available online: <http://www.dos.ny.gov/communitieswaterfronts/consistency/scfwhabitats.html>. Accessed 29 November 2017.

Shortnose Sturgeon Status Review Team (SSSRT). 2010. "Biological Assessment of Shortnose Sturgeon (*Acipenser brevirostrum*)." Available online: http://www.nero.noaa.gov/prot_res/sturgeon/docs/Shortnose%20Sturgeon%20Biological%20Assessment.pdf. Accessed 27 November 2017.

Strayer, D.L. 2006. The benthic animal communities of the tidal-freshwater Hudson River Estuary. Pages 266–278. In J. S. Levinton and J. R. Waldman, ed., *The Hudson River Estuary*. Cambridge University Press, New York.

Sweka, J.A., J. Mohler, M. J. Millard, and T. Kehler. 2007. Juvenile Atlantic Sturgeon Habitat Use in Newburgh and Haverstraw Bays of the Hudson River: Implications for Population Monitoring. *North American Journal of Fisheries Management* 27:1058–1067.

U.S. Department of Energy (USDOE). 2014 "Revised Biological Assessment for Champlain Hudson Power Express Transmission Line Project." July 2014.

U.S. Fish and Wildlife Service (USFWS). 1983. "Recovery Plan for the Indiana Bat." Available online: http://www.fws.gov/midwest/Endangered/mammals/inba/pdf/inba_recplan.pdf. Accessed 28 November 2017.

USFWS. 2017. "Shortnose Sturgeon Fact Sheet." Available online: http://www.fws.gov/northeast/marylandfisheries/reports/Shortnose_fact_sheet_7_21_09.pdf. Accessed 4 December 2017.

USFWS. 2017. "Federally Listed Endangered and Threatened Species and Candidate Species in New York (By County)." 7 November 2017.

USFWS. 2017. "Northern Long-Eared Bat (*Myotis septentrionalis*)." Available online: <http://www.fws.gov/midwest/endangered/mammals/nlba/index.html>. Accessed 29 November 2017.

USFWS. 2017. "Species Profile: Northern Long-Eared Bat (*Myotis septentrionalis*)." Available online: <http://ecos.fws.gov/speciesProfile/profile/speciesProfile.action?spcode=A0JE>. Accessed 27 November 2017.

USFWS. 2017. Species Profile: Shortnose Sturgeon (*Acipenser brevirostrum*). Available online: <http://ecos.fws.gov/speciesProfile/profile/speciesProfile.action?spcode=E00B>. Accessed 28 November 2017.

APPENDIX A

Dredging Figures

File: P:\Jobs\Rem_Eng\Project Files\CHGE\900 CAD\910 CAD\20 SHEETS\PDF\Permitting 2\Permitting Figures.dwg Layout: VICINITY MAP User: erica.hart Plotted: Jan 11, 2018 - 10:06am Xref's:

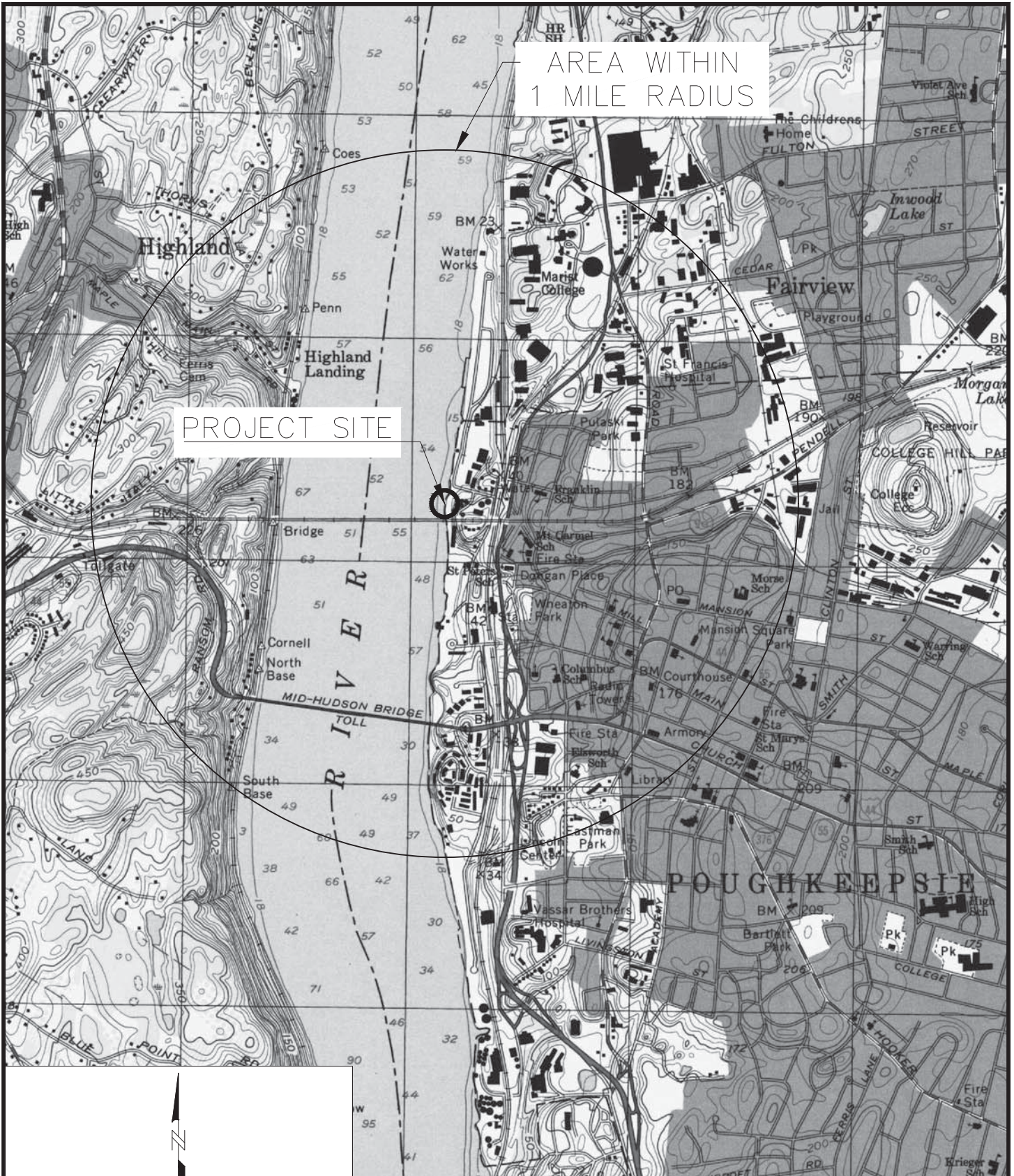

AREA WITHIN 1 MILE RADIUS

PROJECT SITE

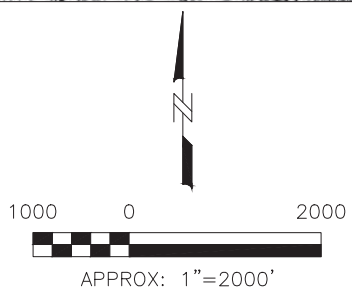

Map Source: U.S.G.S. 7.5' Quadrangle, Poughkeepsie, NY

For Agency Review Only



CENTRAL HUDSON GAS & ELECTRIC
HUDSON RIVER
DUTCHESS COUNTY, NY







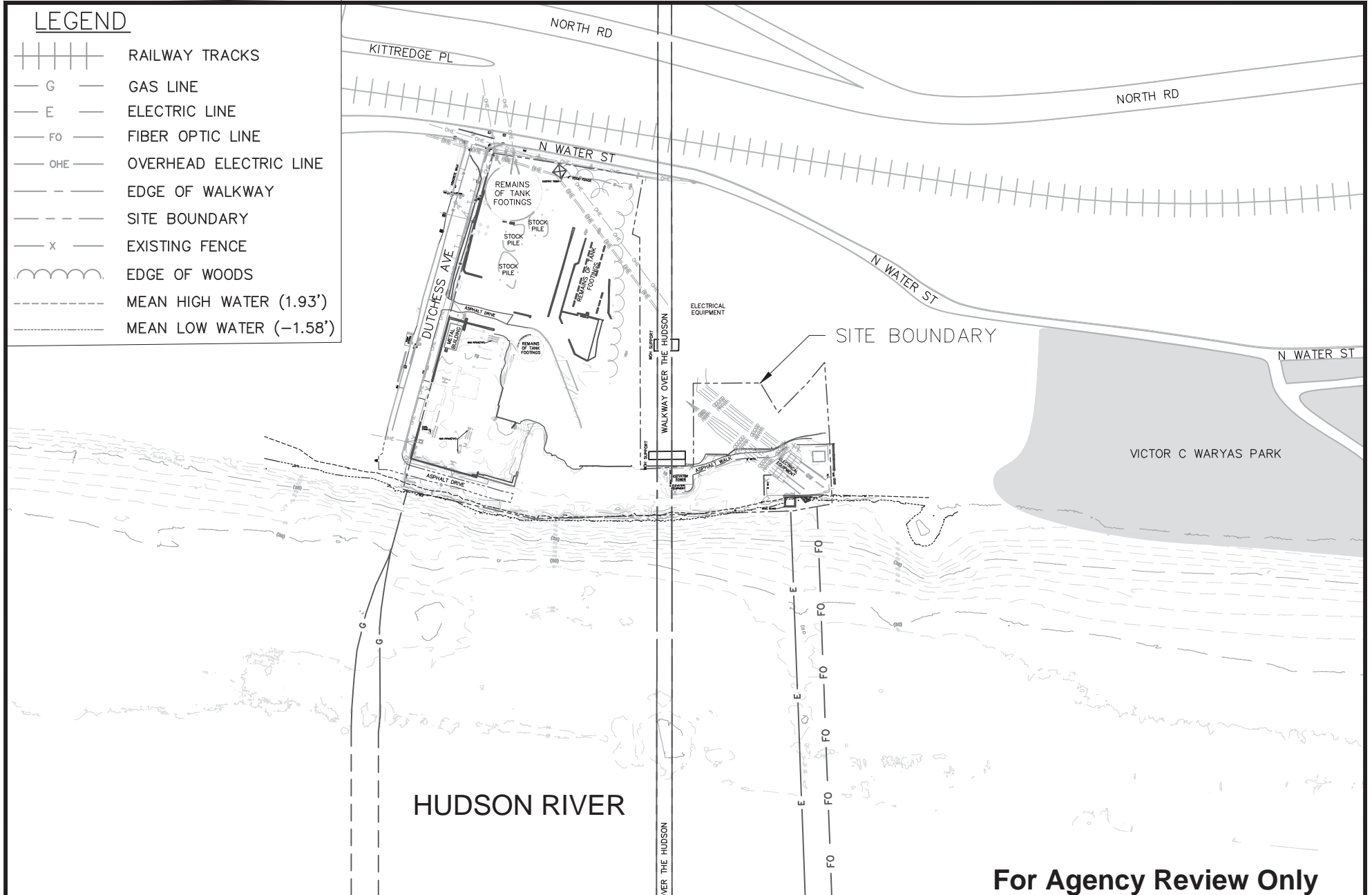





VICINITY MAP
FORMER NORTH WATER STREET MGP
POUGHKEEPSIE

DATE: 1/11/18

FIGURE 1 OF 11

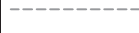

LEGEND

-  RAILWAY TRACKS
-  G GAS LINE
-  E ELECTRIC LINE
-  FO FIBER OPTIC LINE
-  OHE OVERHEAD ELECTRIC LINE
-  --- EDGE OF WALKWAY
-  - - - SITE BOUNDARY
-  X EXISTING FENCE
-   EDGE OF WOODS
-  - - - MEAN HIGH WATER (1.93')
-  - - - MEAN LOW WATER (-1.58')

For Agency Review Only

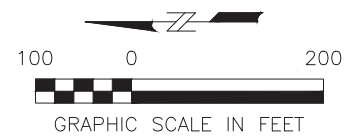

CENTRAL HUDSON GAS & ELECTRIC
 HUDSON RIVER
 DUTCHESS COUNTY, NY
 DATE: 1/11/18

CURRENT SITE LAYOUT AND
 KNOWN UTILITIES
 FORMER NORTH WATER STREET MGP
 POUGHKEEPSIE, NY
 FIGURE 2 OF 11

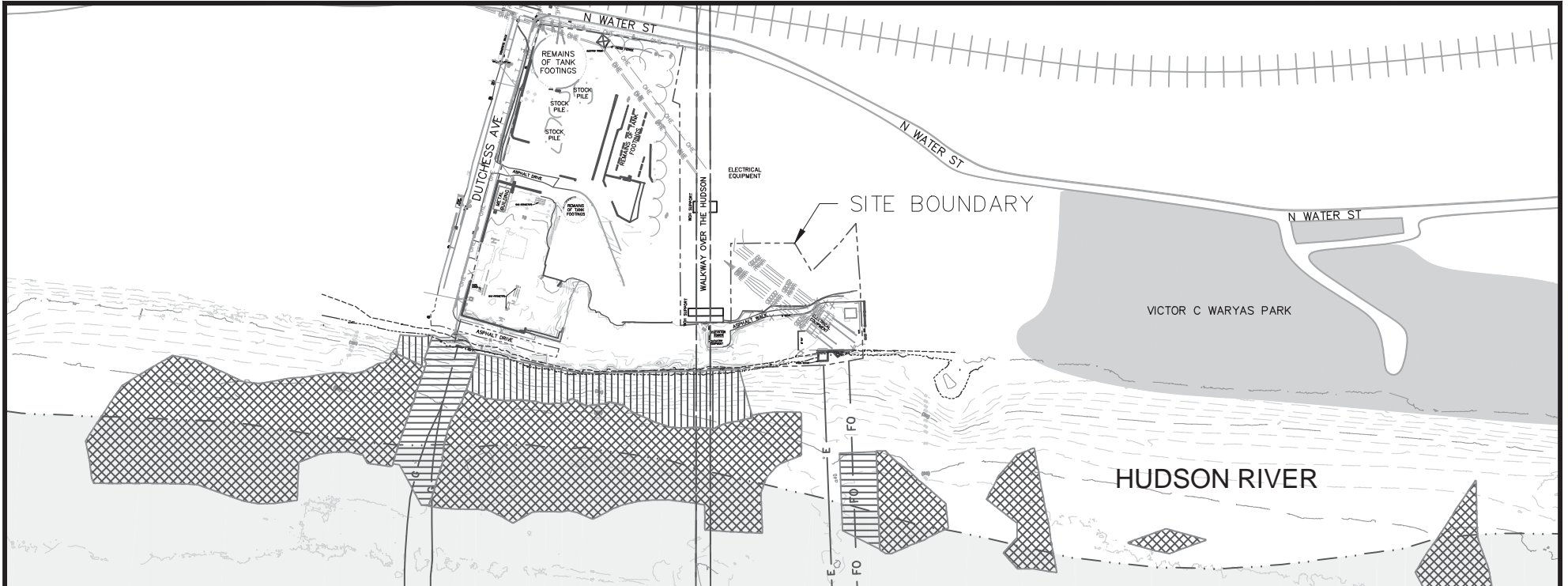

LEGEND

- | | | | |
|--|-------------------------|--|-----------------------------|
| | RAILWAY TRACKS | | PROPOSED SLOPE GRADING AREA |
| | GAS LINE | | PROPOSED UTILITY CAP AREA |
| | ELECTRIC LINE | | DREDGE AREA |
| | FIBER OPTIC LINE | | |
| | OVERHEAD ELECTRIC LINE | | |
| | EDGE OF WALKWAY | | |
| | SITE BOUNDARY | | |
| | EXISTING FENCE | | |
| | EDGE OF WOODS | | |
| | SCFWH AREA BOUNDARY | | |
| | MEAN HIGH WATER (1.93') | | |
| | MEAN LOW WATER (-1.58') | | |

KINGSTON-POUGHKEEPSIE DEEPWATER SCFWH AREA

For Agency Review Only

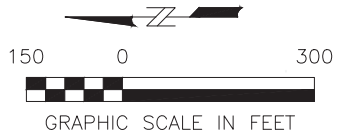

CENTRAL HUDSON GAS & ELECTRIC
HUDSON RIVER
DUTCHESS COUNTY, NY

DATE: 1/11/18

REMEDIAL ACTIVITIES PLAN
FORMER NORTH WATER STREET MGP
POUGHKEEPSIE, NY

FIGURE 3 OF 11

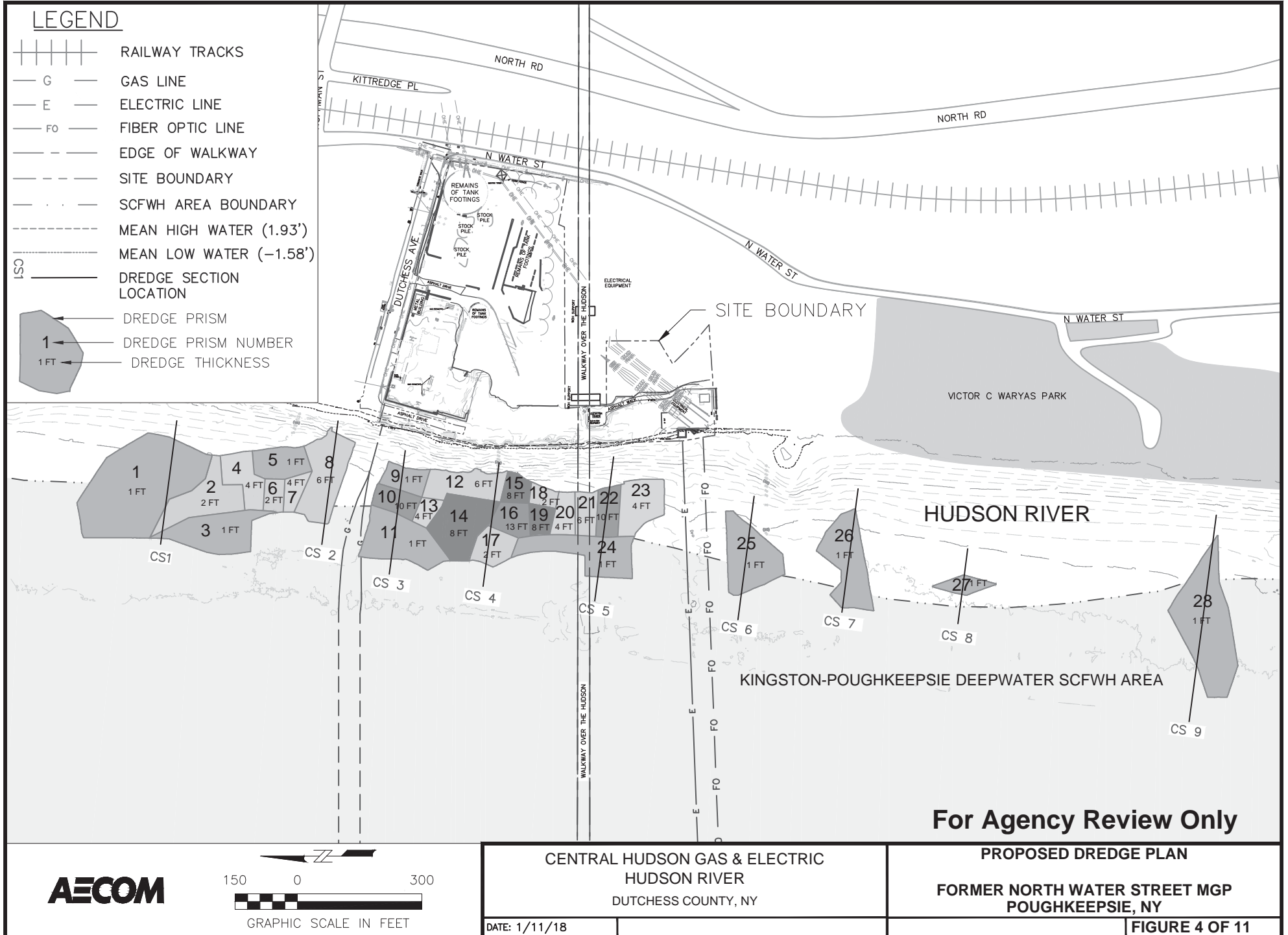

For Agency Review Only

DREDGE SECTION 2

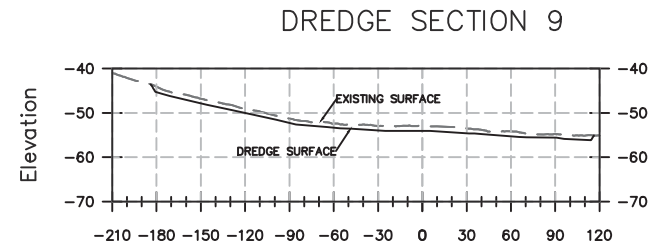
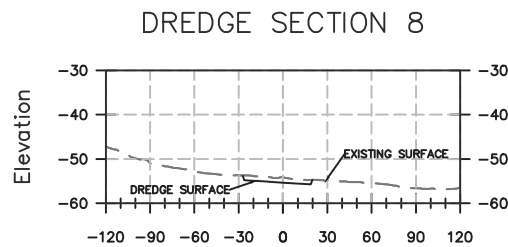
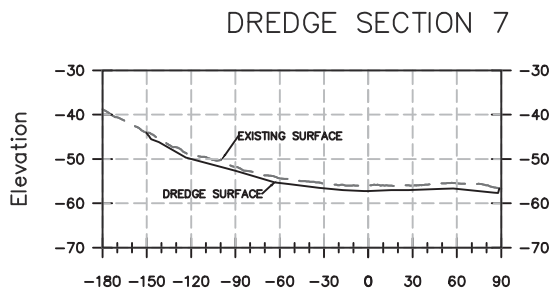
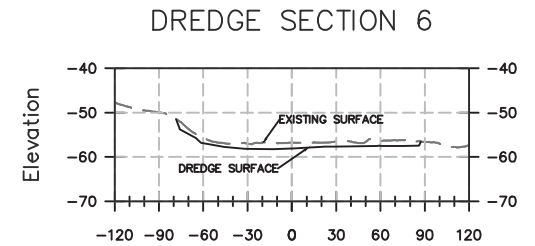
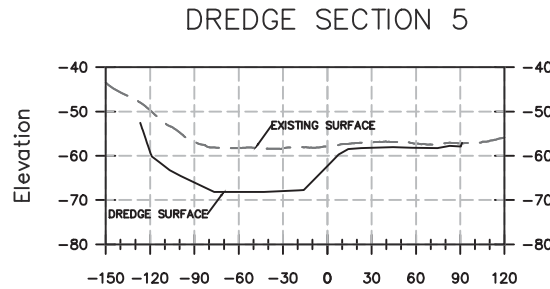
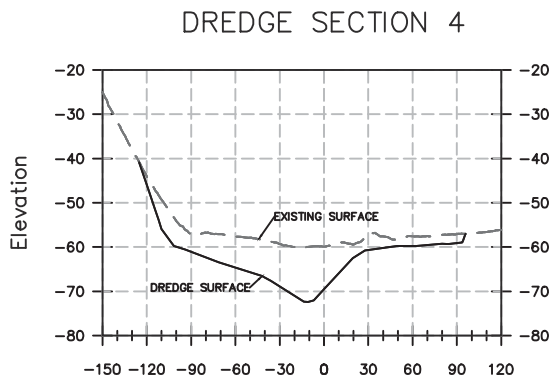
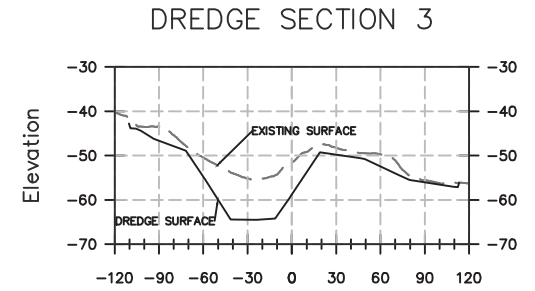
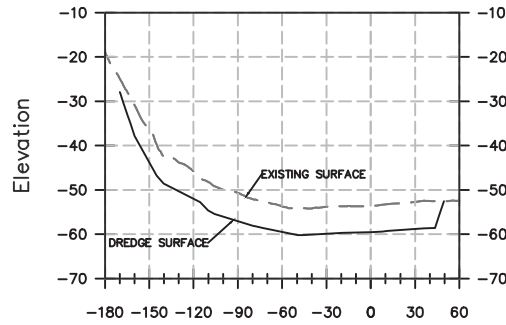
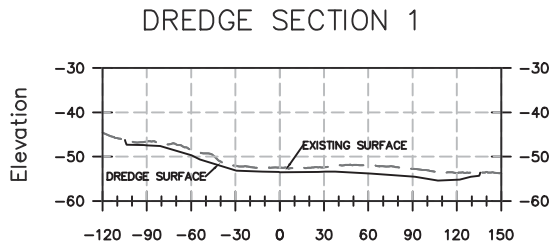

For Agency Review Only



CENTRAL HUDSON GAS & ELECTRIC
HUDSON RIVER
DUTCHESS COUNTY, NY

PROPOSED DREDGE PLAN
CROSS SECTIONS
FORMER NORTH WATER STREET MGP
POUGHKEEPSIE, NY

DATE: 1/11/18

FIGURE 5 OF 11

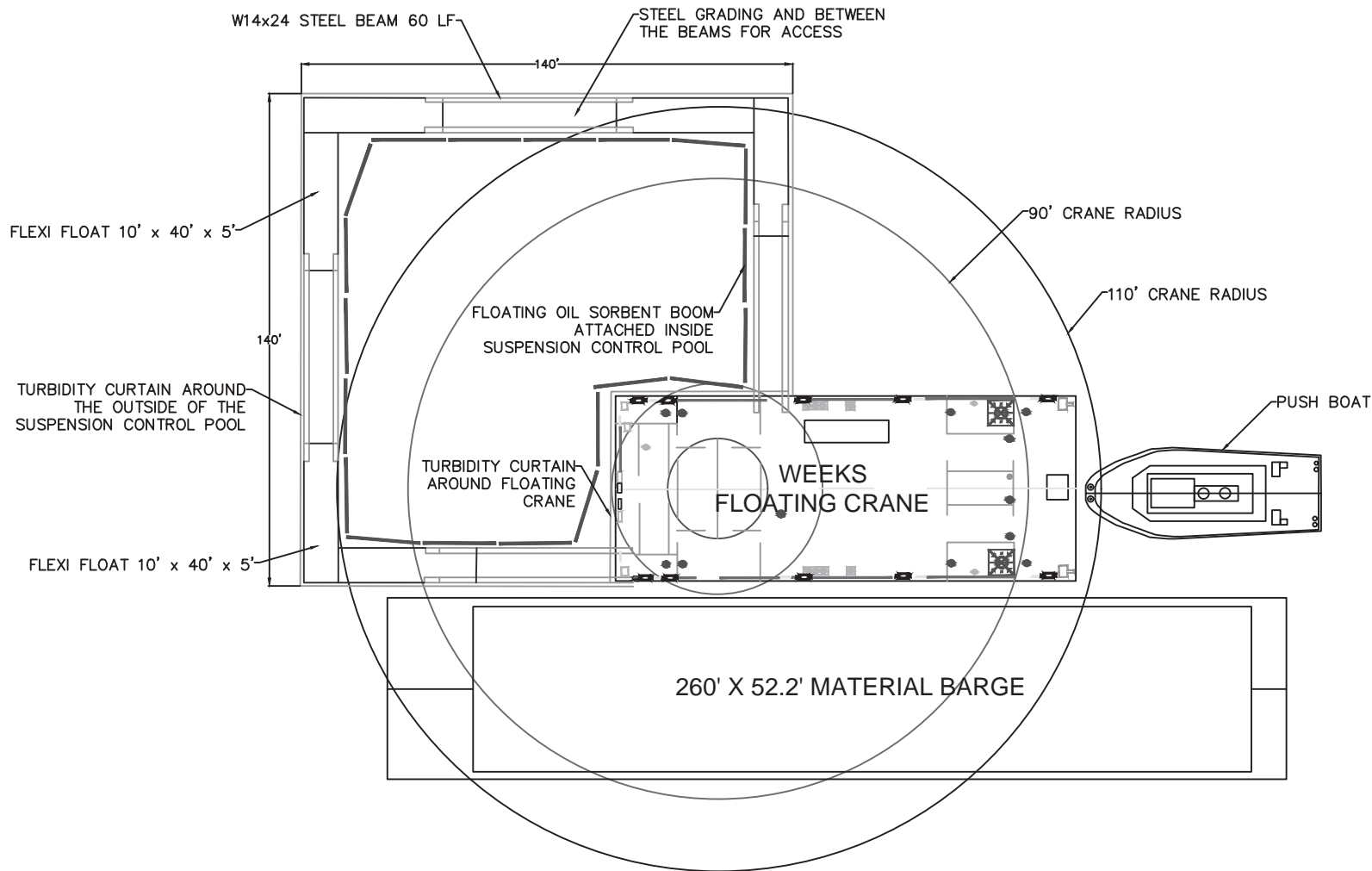

MOBILE SUSPENSION CONTROL SYSTEM SETUP OVERVIEW

NOTE: FIGURES NOT DRAWN TO SCALE. THESE ARE CONCEPTUAL DRAWINGS.

For Agency Review Only



CENTRAL HUDSON GAS & ELECTRIC
HUDSON RIVER
DUTCHESS COUNTY, NY

ENGINEERING CONTROLS
PLAN VIEW
FORMER NORTH WATER STREET MGP
POUGHKEEPSIE, NY

DATE: 1/11/18

FIGURE 6A OF 11

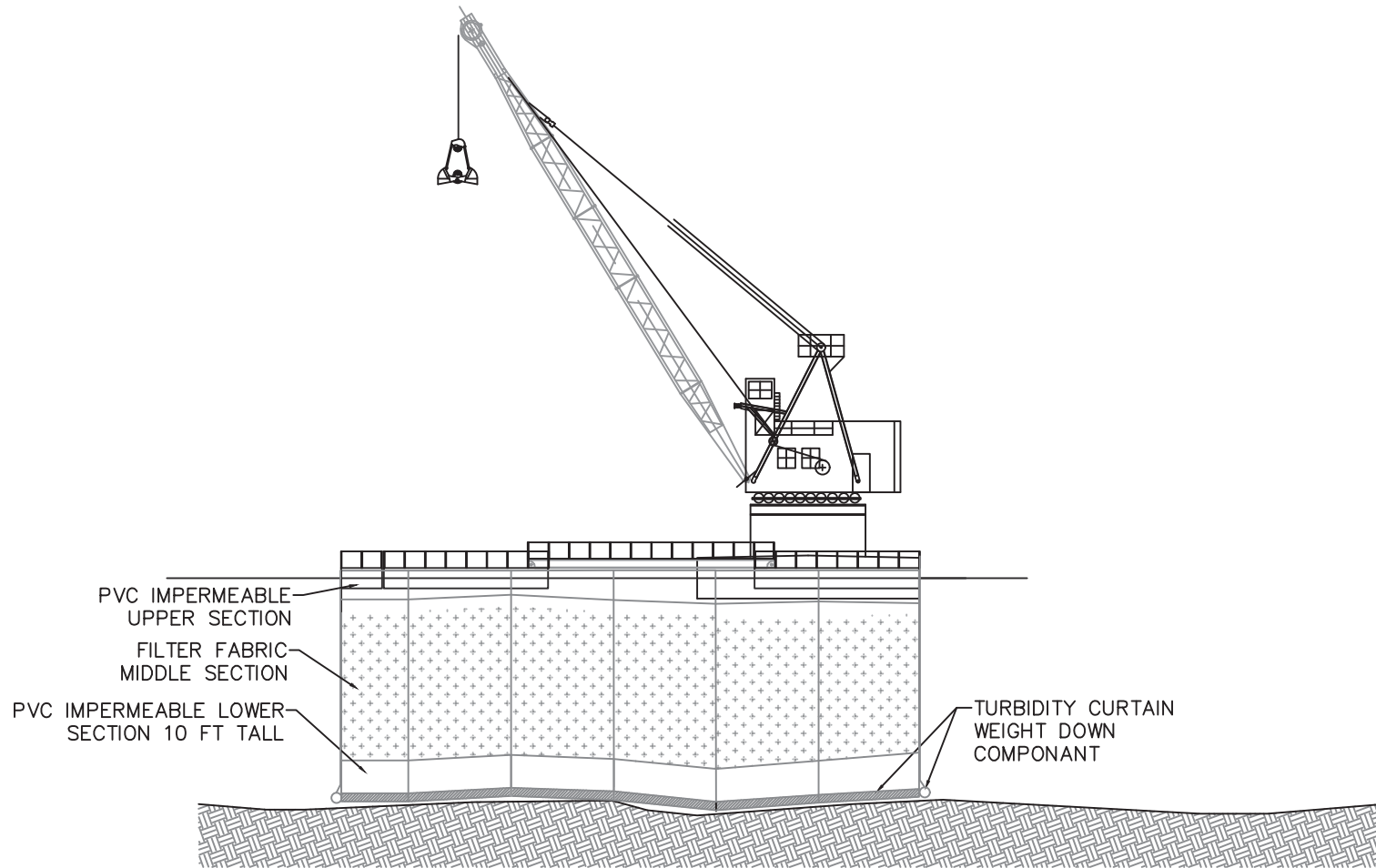

MOBILE SUSPENSION CONTROL SYSTEM SETUP
FRONT VIEW

NOTE: FIGURES NOT DRAWN TO SCALE. THESE ARE CONCEPTUAL DRAWINGS.

For Agency Review Only



CENTRAL HUDSON GAS & ELECTRIC
HUDSON RIVER
DUTCHESS COUNTY, NY

ENGINEERING CONTROLS
SIDE VIEW
FORMER NORTH WATER STREET MGP
POUGHKEEPSIE, NY

DATE: 1/11/18

FIGURE 6B OF 11

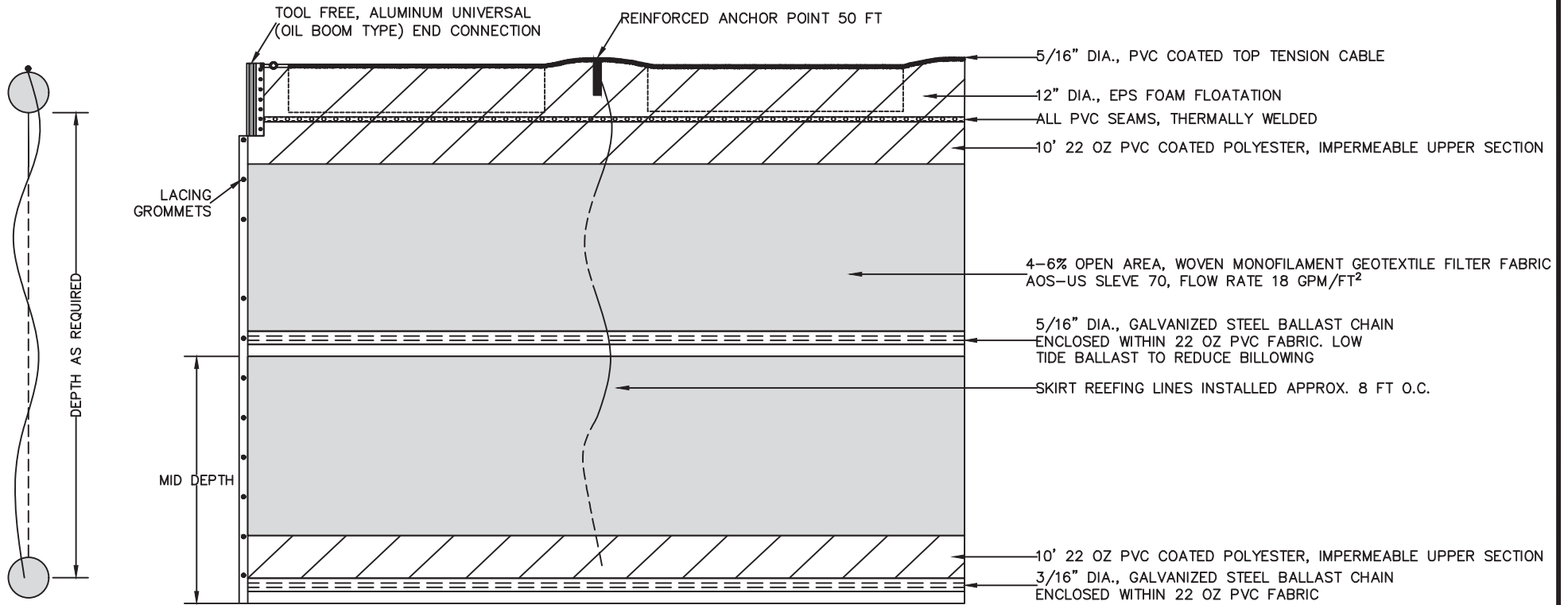

TURBIDITY BARRIER DETAIL

NOTE: FIGURES NOT DRAWN TO SCALE. THESE ARE CONCEPTUAL DRAWINGS.

For Agency Review Only



CENTRAL HUDSON GAS & ELECTRIC
HUDSON RIVER
DUTCHESS COUNTY, NY

ENGINEERING CONTROLS
DETAIL
FORMER NORTH WATER STREET MGP
POUGHKEEPSIE, NY

DATE: 1/11/18

FIGURE 6C OF 11

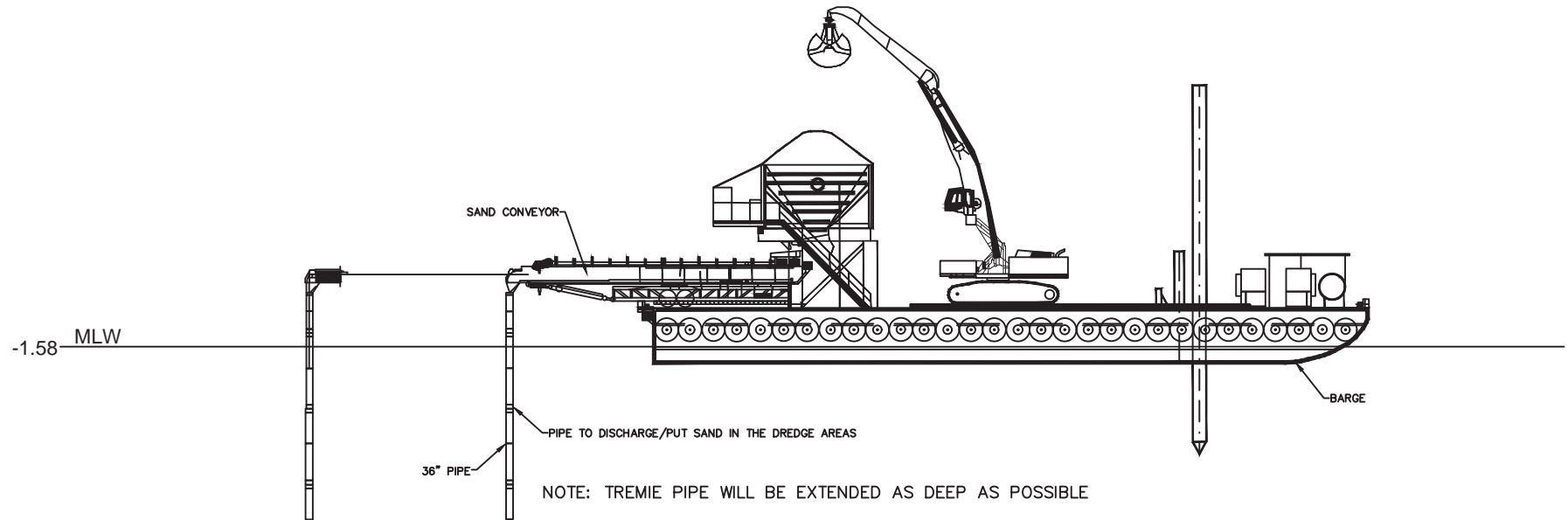

CONCEPTUAL DREDGE RESTORATION OPERATION

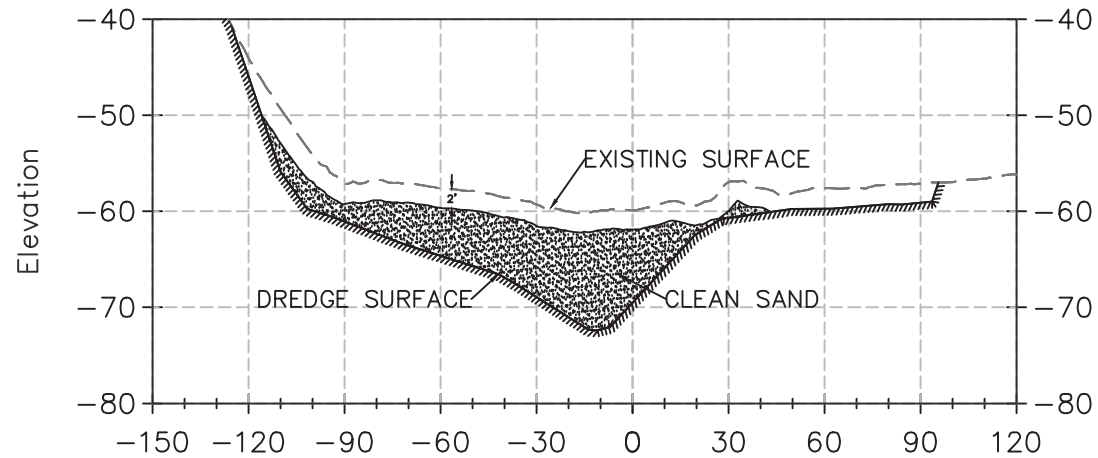

For Agency Review Only



CENTRAL HUDSON GAS & ELECTRIC
HUDSON RIVER
DUTCHESS COUNTY, NY

DREDGE AREA RESTORATION PLAN
FORMER NORTH WATER STREET MGP
POUGHKEEPSIE, NY

DATE: 1/11/18

FIGURE 7 OF 11

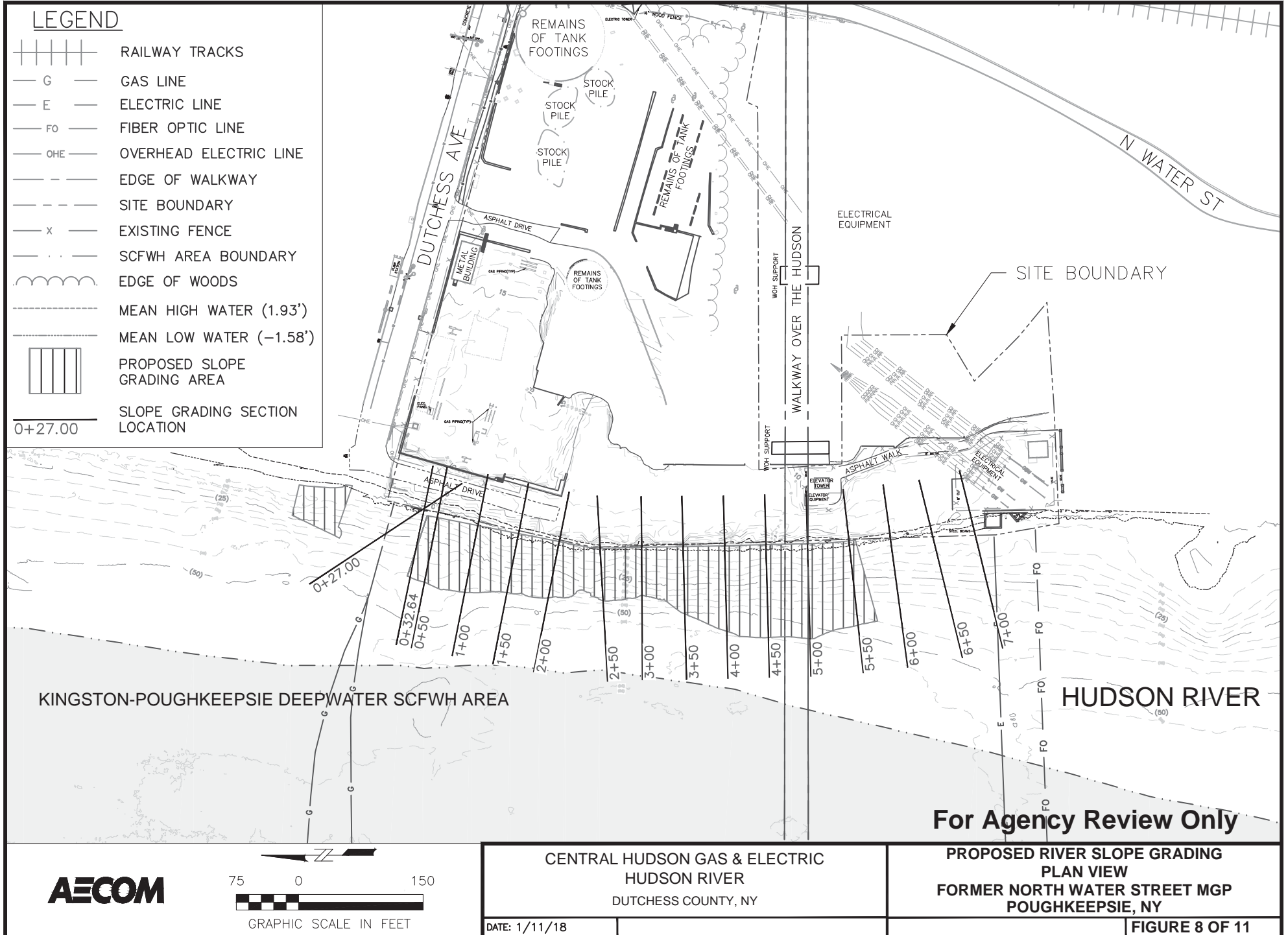

LEGEND

- ORIGINAL SLOPE SURFACE
- RESTORED CAP SURFACE
- · - · - DREDGE SURFACE
- - - - - MEAN HIGH WATER (1.93')
- MEAN LOW WATER (-1.58')

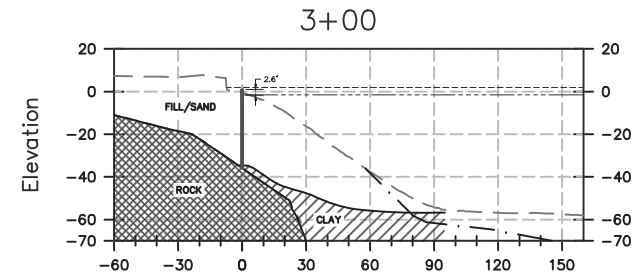
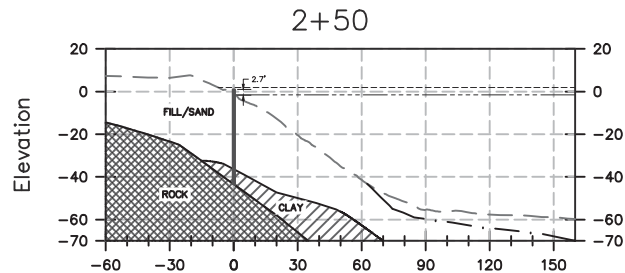
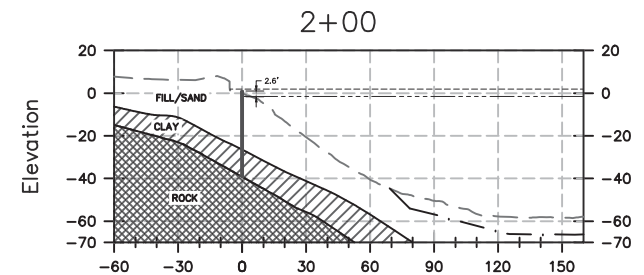
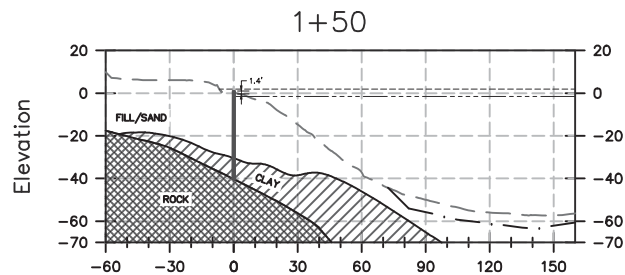
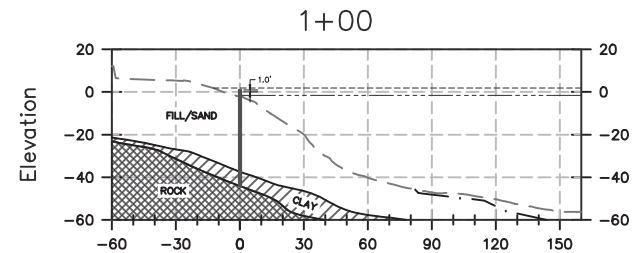
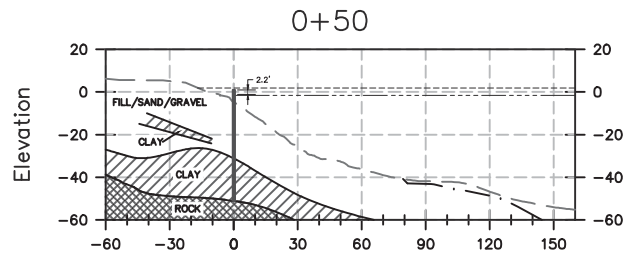
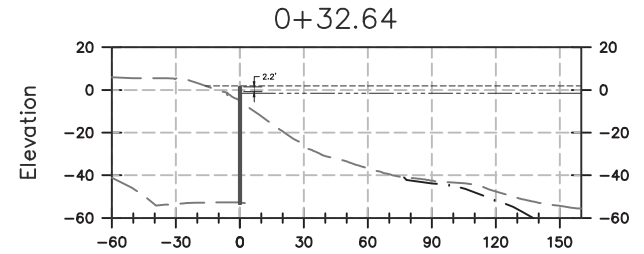
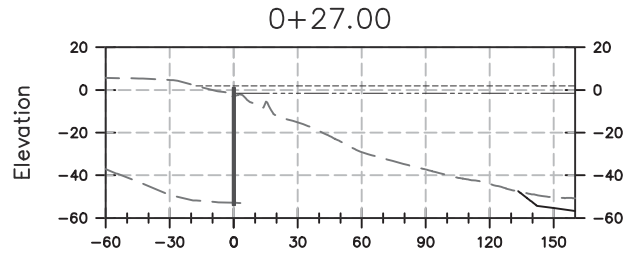

For Agency Review Only



CENTRAL HUDSON GAS & ELECTRIC
HUDSON RIVER
DUTCHESS COUNTY, NY

PROPOSED RIVER SLOPE GRADING
CROSS SECTIONS
FORMER NORTH WATER STREET MGP
POUGHKEEPSIE, NY

DATE: 1/11/18

FIGURE 9A OF 11

LEGEND

- ORIGINAL SLOPE SURFACE
- RESTORED CAP SURFACE
- . - . DREDGE SURFACE
- - - - - MEAN HIGH WATER (1.93')
- MEAN LOW WATER (-1.58')

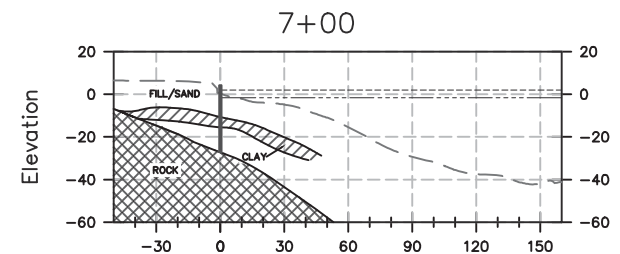
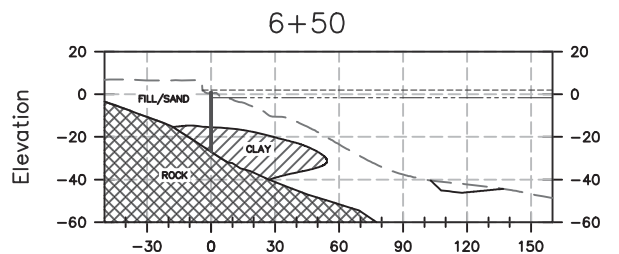
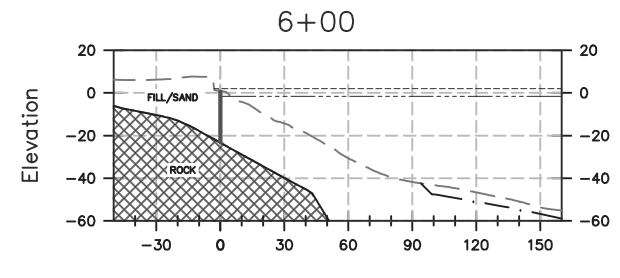
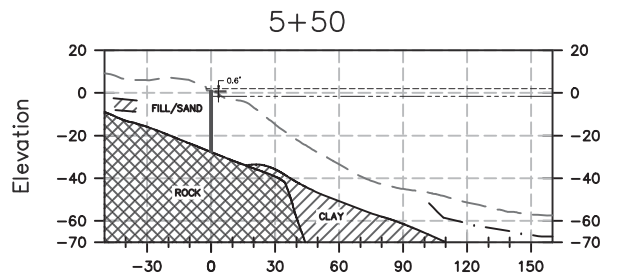
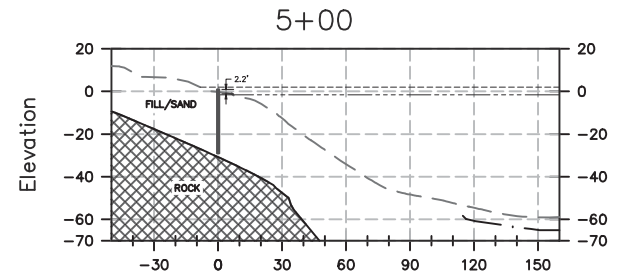
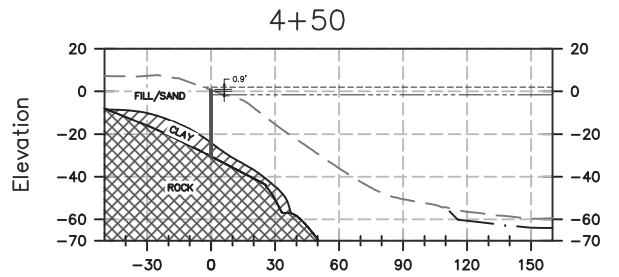
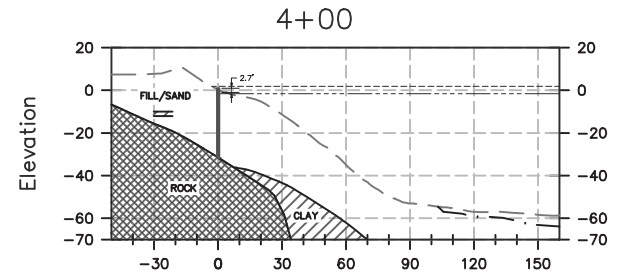
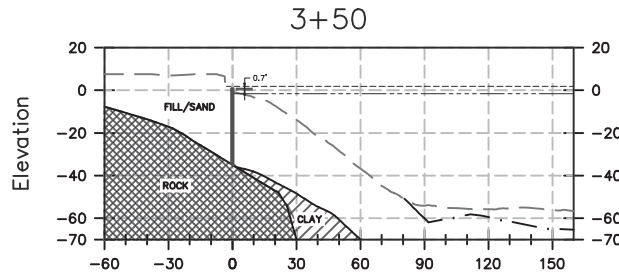

For Agency Review Only



CENTRAL HUDSON GAS & ELECTRIC
HUDSON RIVER
DUTCHESS COUNTY, NY

PROPOSED RIVER SLOPE GRADING
CROSS SECTIONS
FORMER NORTH WATER STREET MGP
POUGHKEEPSIE, NY

DATE: 1/11/18

FIGURE 9B OF 11

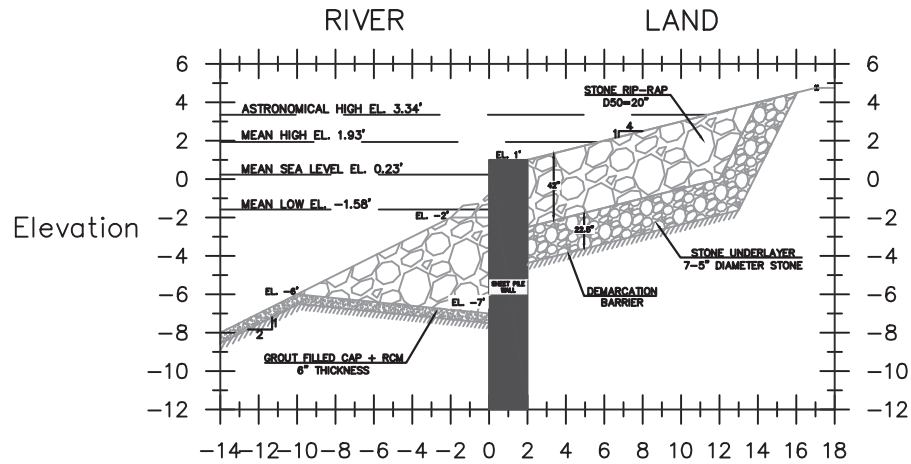

PROPOSED SIDE SLOPE RESTORATION

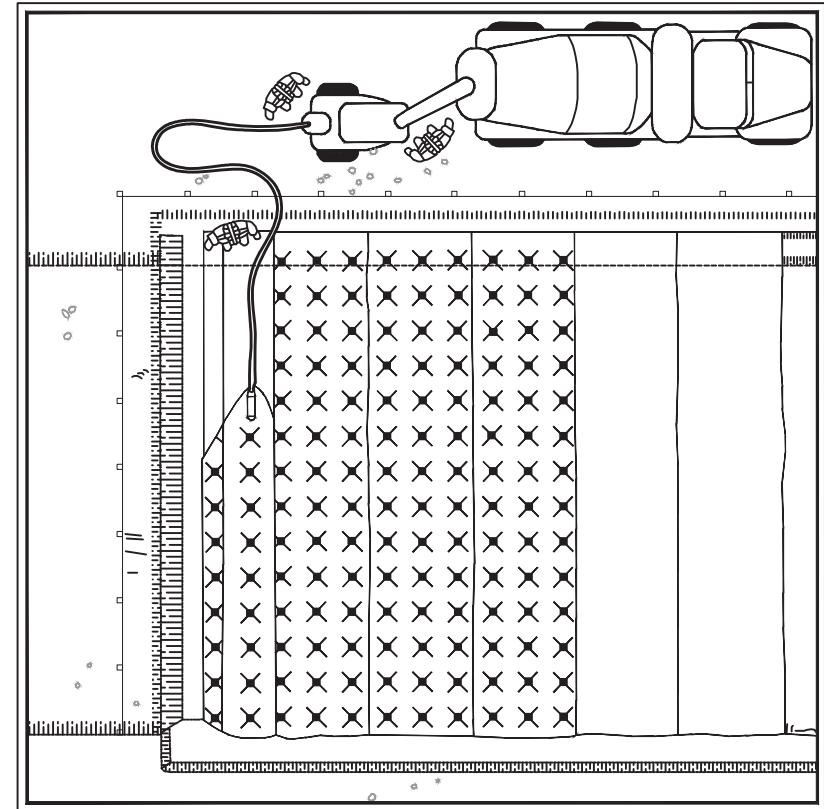

REACTIVE CORE MAT OVERLAID WITH CONCRETE MATTRESSES
ISOMETRIC VIEW

For Agency Review Only



CENTRAL HUDSON GAS & ELECTRIC HUDSON RIVER DUTCHESS COUNTY, NY	DETAILS FOR SIDE SLOPE CAP FORMER NORTH WATER STREET MGP POUGHKEEPSIE, NY
DATE: 1/11/18	FIGURE 10 OF 11

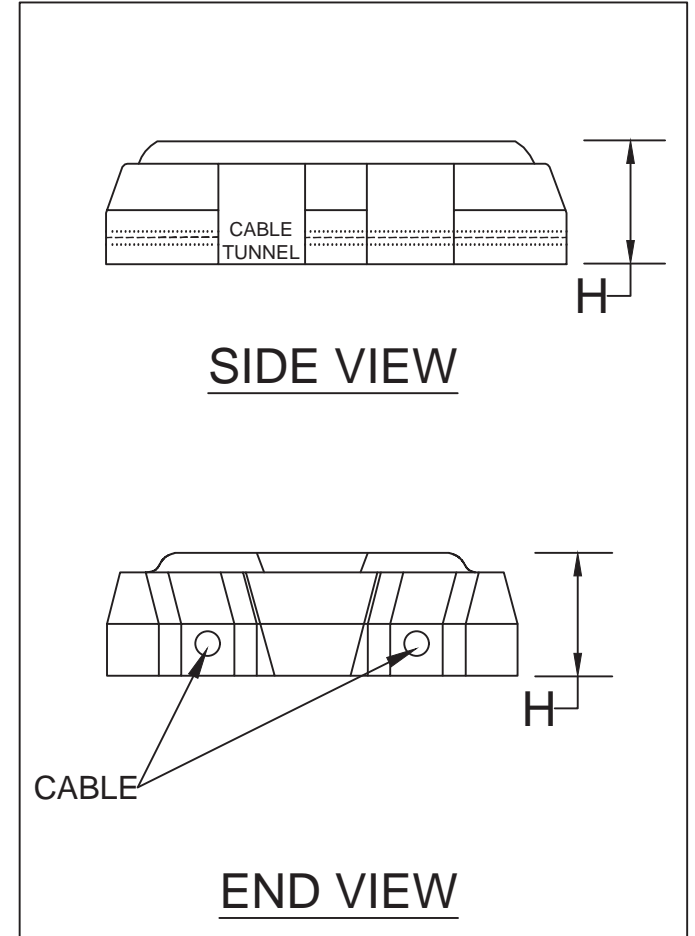
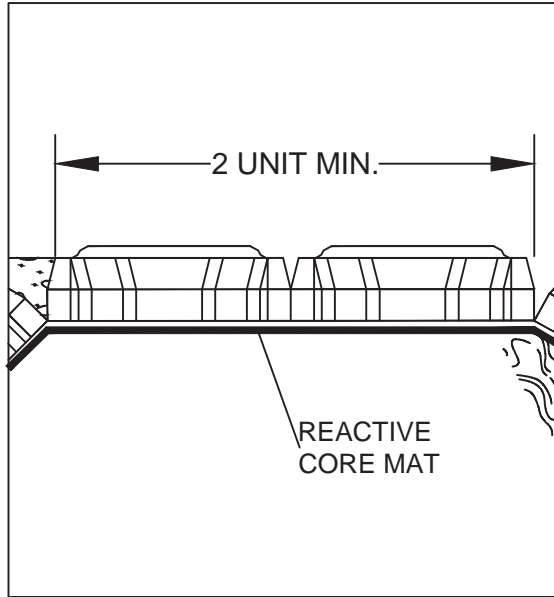
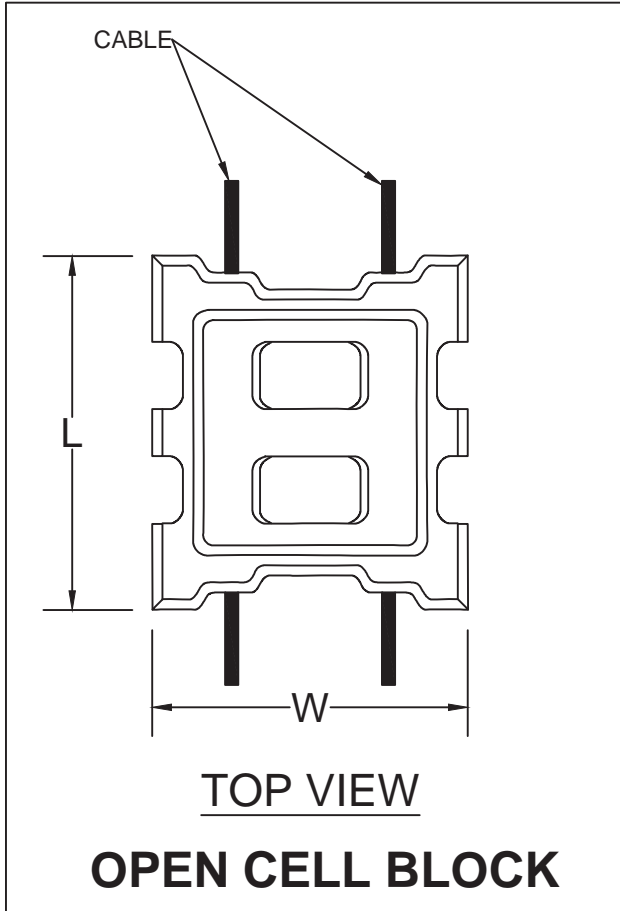

For Agency Review Only



CENTRAL HUDSON GAS & ELECTRIC
HUDSON RIVER
DUTCHESS COUNTY, NY

DETAILS FOR UTILITY CAP
FORMER NORTH WATER STREET MGP
POUGHKEEPSIE, NY

DATE: 1/11/18

FIGURE 11 OF 11

APPENDIX B

Product Description Sheets – Slope Stabilization Material

REACTIVE CORE MAT™

WITH ORGANOCLAY®

DESCRIPTION

ORGANOCLAY® REACTIVE CORE MAT™ is a permeable composite of geotextiles and granular ORGANOCLAY that reliably adsorbs NAPL and low solubility organics from water. Batch isotherm testing by a university determined the following partition coefficients:

- Naphthalene, Kd = 3280 L/kg
- Phenanthrene, Kd = 117,000 L/kg
- Pyrene, Kd - 286,000 L/kg

APPLICATION

ORGANOCLAY® REACTIVE CORE MAT™ is designed for use in the following applications:

- In situ subaqueous cap for contaminated sediments or post-dredge residual sediments
- Embankment seepage control
- Groundwater remediation

BENEFITS

- ORGANOCLAY® REACTIVE CORE MAT™ provides a reactive material that treats contaminants carried by advective/diffusive flow
- Reactive cap allows for thinner cap thickness than a traditional sand cap
- Geotextiles provide stability and physical isolation of contaminants

AVAILABILITY

ORGANOCLAY® REACTIVE CORE MAT™ is available from the following CETCO plant locations:

- 92 Highway 37, Lovell, WY



REACTIVE CORE MAT™ is designed to provide a simple method of placing active materials into subaqueous sediment caps.

PACKAGING

15' by 100' rolls, packaged on 4" PVC core tubes wrapped with polyethylene plastic packaging.

TESTING DATA

PHYSICAL PROPERTIES		
PROPERTY	TEST METHOD	RESULT
ORGANOCLAY¹		
Bulk Density Range	ASTM D 7481	44 - 56 lbs/ft ³
Oil Adsorption Capacity	CETCO Test Method	0.5 lb of oil per lb of ORGANOCLAY, min
Quaternary Amine Content	ASTM D 7626	25 - 33% quaternary amine loading
FINISHED RCM PRODUCT		
ORGANOCLAY Mass per Area	CETCO Test Method	0.8 lb/ft ²
Mat Grab Strength ²	ASTM D4632	90 lbs. MARV
Hydraulic Conductivity ³	ASTM D4491	1 x 10 ⁻³ cm/sec minimum

NOTES:

¹ ORGANOCLAY properties performed periodically on material prior to incorporation into the RCM

² All tensile testing is performed in the machine direction

³ Permittivity at constant head of 2 inches and converted to hydraulic conductivity using Darcy's Law and RCM thickness per ASTM D5199 for geotextiles

North America: 847.851.1800 | 800.527.9948 | www.CETCO.com

© 2014 CETCO. IMPORTANT: The information contained herein supersedes all previous printed versions, and is believed to be accurate and reliable. For the most up-to-date information, please visit www.CETCO.com. CETCO accepts no responsibility for the results obtained through application of this product. CETCO reserves the right to update information without notice.

UPDATED: NOVEMBER 2013

TDS_RCM-ORGANOCLAY_AM_EN_201311_v1



Armortec Product Details

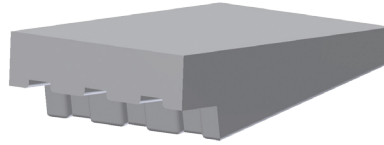

ArmorWedge[®]

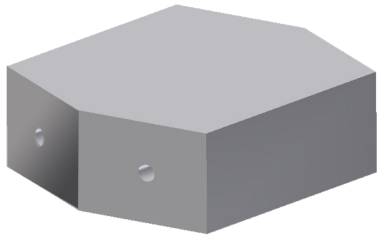

ArmorRoad[®]

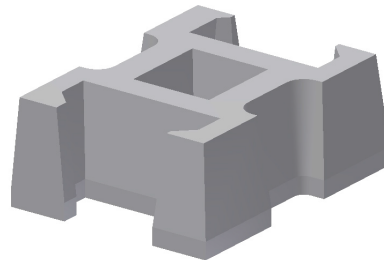

ArmorLoc[®]

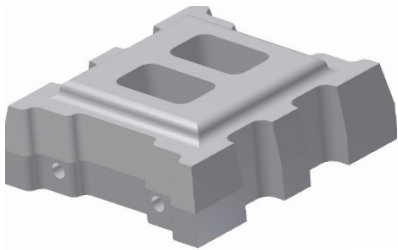

ArmorFlex[®] - Open Cell

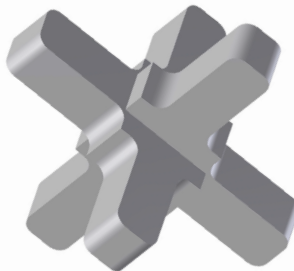

A-Jacks[®]

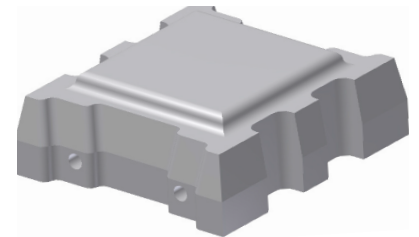

ArmorFlex[®] - Close Cell

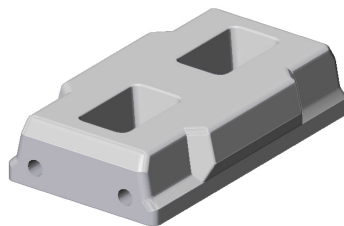

ArmorStone[®]

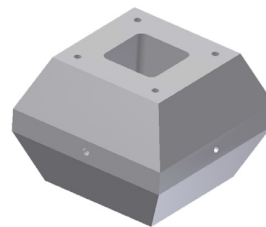

ArmorFlex[®] OS

MANUFACTURING SPECIFICATION
ASTM D6684-04

ArmorFlex® (not to scale)

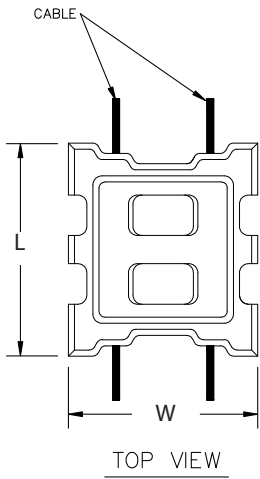

Open Cell Block

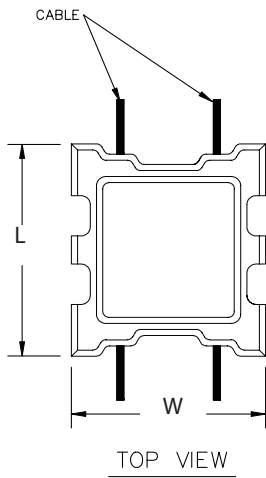

Close Cell Block

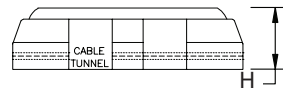

SIDE VIEW

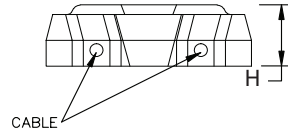

END VIEW

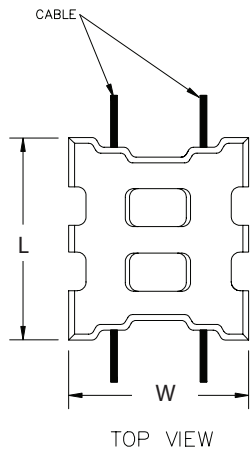

Tapered Series

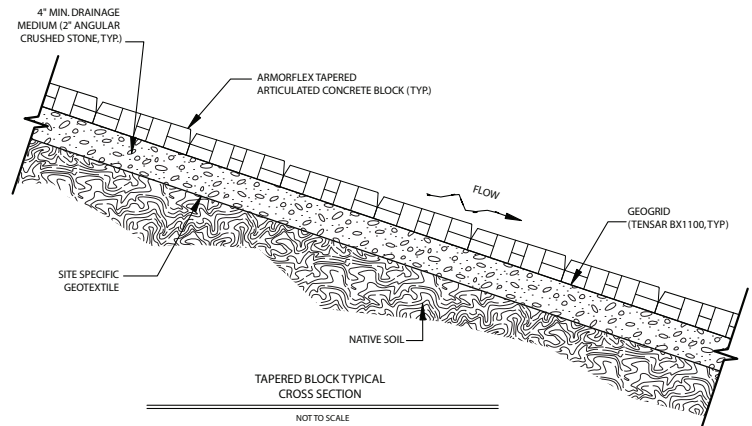
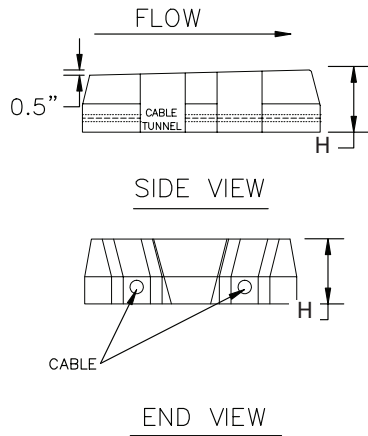

Tapered Series - Cross Section

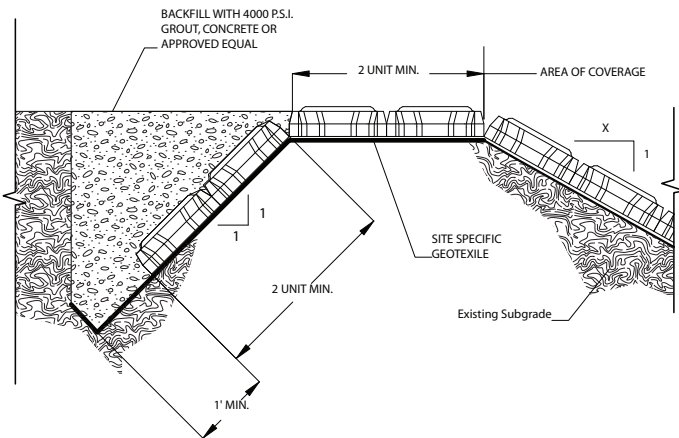

Top of Slope - Standard Detail

ArmorFlex Unit Specification

Concrete Block Class	Open/Closed Cell	Nominal Dimensions			Gross Area/ (sq. ft.)	Block Weight		Open Area %
		L	W	H		lbs	lbs/sq. ft.	
30s	Open	13.0	11.6	4.75	0.98	31-36	32-37	20
50s	Open	13.0	11.6	6.00	0.98	45-52	45-53	20
40	Open	17.4	15.5	4.75	1.77	62-71	35-40	20
50	Open	17.4	15.5	6.00	1.77	81-94	46-53	20
70	Open	17.4	15.5	8.50	1.77	120-138	68-78	20
40L	Open	17.4	23.6	4.75	2.58	90-106	35-41	20
70L	Open	17.4	23.6	8.50	2.58	173-201	67-78	20
45s	Closed	13.0	11.6	4.75	0.98	39-45	40-45	10
55s	Closed	13.0	11.6	6.00	0.98	53-61	54-62	10
45	Closed	17.4	15.5	4.75	1.77	78-89	43-50	10
55	Closed	17.4	15.5	6.00	1.77	94-108	53-61	10
85	Closed	17.4	15.5	8.50	1.77	145-167	82-98	10
45L	Closed	17.4	23.6	4.75	2.58	108-126	42-49	10
85L	Closed	17.4	23.6	8.50	2.58	209-243	81-94	10

High Velocity Application Block Classes

40-T	Open	17.4	15.5	4.75	1.77	62-71	35-40	20
50-T	Open	17.4	15.5	6.00	1.77	81-94	46-53	20
70-T	Open	17.4	15.5	8.50	1.77	120-138	68-78	20

ArmorFlex® cont. (not to scale)

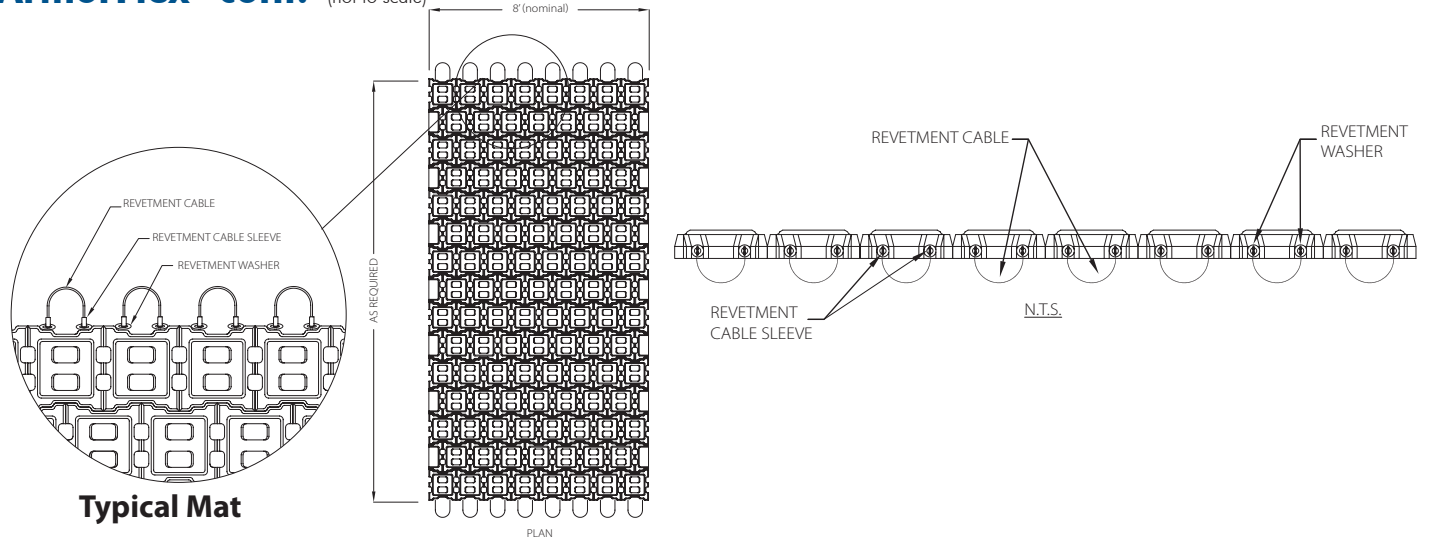

A-Jacks® (not to scale)

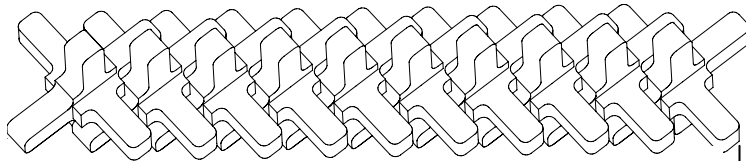

A-Jacks Placement Profile

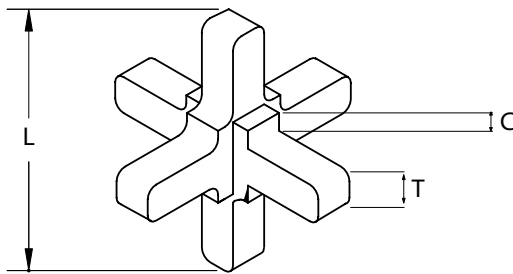

A-Jacks Unit

A-Jacks Unit Specification

A-JACKS	L(IN)	T(IN)/H(IN)	C(IN)	VOL(FT³)	WT (LBS)
AJ-24	24	4	1.84	0.56	78
AJ-48	48	7.36	3.68	4.49	629
AJ-72	72	11.04	5.52	15.14	2.120
AJ-96	96	14.72	7.396	35.87	5.022
AJ-120	120	18.40	9.20	70.69	9.699

ArmorWedge® (not to scale)

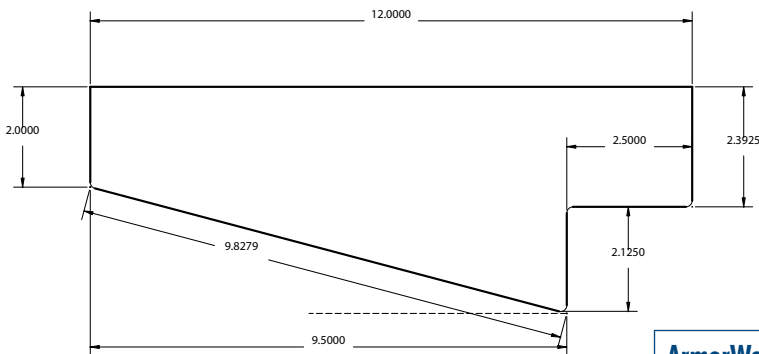

Side View - Typical Block

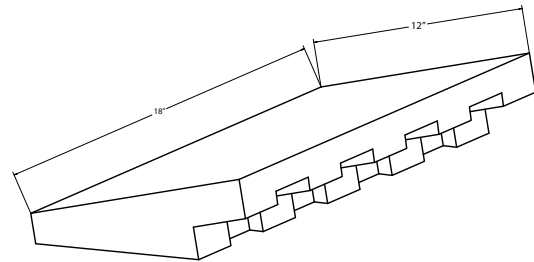

ArmorWedge Unit Specification

UNIT DIMENSION	UNIT WEIGHT (LBS)	SYSTEM WEIGHT (LBS)	UNIT COVERAGE (SF)	COMPRESSIVE STRENGTH (PSI)	MAXIMUM ABSORPTION (LBS/FT³)
12x18	40-52	36-40	1.1875	4000	12

ArmorLoc® (not to scale)

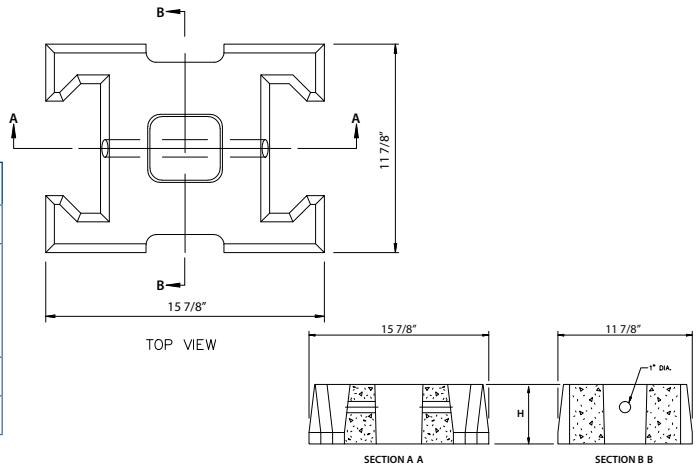

ArmorLoc Unit Specification

BLOCK	TECHNICAL DATA			DIMENSIONS AND WEIGHTS				
	Specific Weight lbs/ft ³	Compressive Strength psi	Max Absorption, Avg. of 3 units 10 lbs/ft ³	Thickness Inches (H)	Gross Area/ Grid ft ²	Weights/ Grid lbs	Weights/ Area lbs/ft ²	Open Area %
3510	130-150	4000 min	10	4	1.0	30-35	30-35	25
4511	130-150	4000 min	10	5.25	1.1	44-50	40-45	20

ArmorStone® (not to scale)

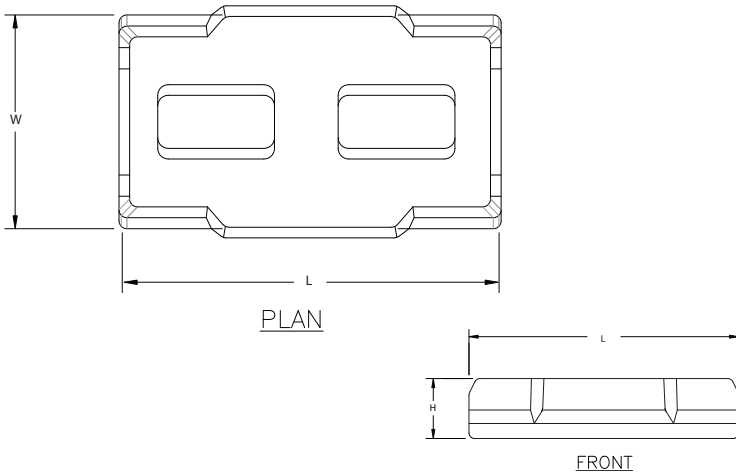

ArmorStone Unit Specification

CONCRETE BLOCK CLASS		NOMINAL DIMENSIONS (IN.)			UNIT COVERAGE (SF)	BLOCK		OPEN AREA %
		L	W	H		UNIT WEIGHT LBS.	SYSTEMS WEIGHTS LBS./SF	
AS 40	Open	18.00	10.00	4.50	1.25	50-54	40-44	25
AS 55	Closed	18.00	10.00	4.50	1.25	61-66	49-53	5

ArmorRoad® (not to scale)

ArmorRoad Unit Specification

BLOCK	TYPE	L	W	H	SF COVERAGE PER UNIT	WEIGHT LBS PER UNIT	SF PER TRUCK LOAD
Mat	Closed	18.00	15.60	6.00	1.74	105-109	750
Individual	Closed	18.00	15.60	6.00	1.74	100-104	750

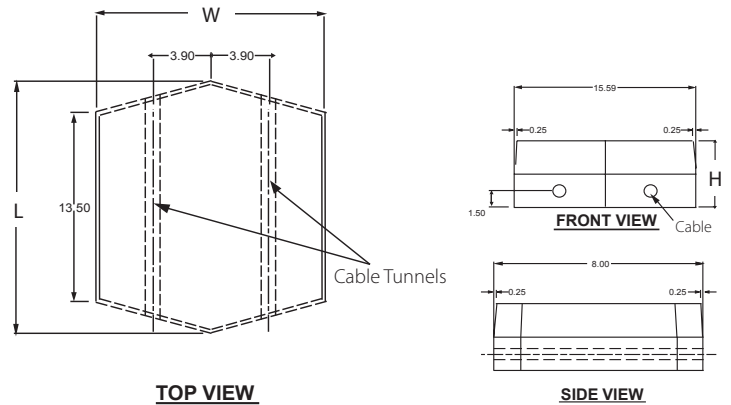

Armortec Minimum Physical Requirements per ASTM 06684-04

MIN. DENSITY (IN AIR) LBS/FT ³		MIN. COMPRESSIVE STRENGTH PSI		MAX WATER ABSORPTION LBS/FT ³	
Ave. of 3 Units	Individual Unit	Ave. of 3 Units	Individual Unit	Ave. of 3 Units	Individual Unit
130	125	4,000	3,500	9.1	11.7

Manufactured by Geostar Corporation

Filter Point
Filter Band™
Uniform Section
Enviromat™
Articulating Block
Hydrocast™ Armor Units

HYDROTEX™

Fabric-formed Concrete Erosion Control and Armoring Systems



CONSTRUCTION &
QUALITY CONTROL
MANUAL

Hydrotex, Hydrocast, Filter Band, and Enviromat are trademarks of Geostar Corporation.
© 2001, Geostar Corporation. Printed in U.S.A.

The information contained herein was derived based on the use of products manufactured by Geostar Corporation. Their use or application with the products of another manufacturer is not recommended, due to differences in material composition or differences in manufacturing technique, and may produce unintended results. This information is intended for the use of the entity or individual to whom it is addressed and may contain information that is privileged, confidential and exempt for disclosure under applicable law.

The information contained herein is furnished without charge or obligation, and the recipient assumes all responsibility for its use. Because conditions of use and handling may vary and are beyond our control, we make no representation about, and are not responsible for, the accuracy or reliability of said information or the performance of any product. Any specifications, properties or applications listed are provided as information only and in no way modify, enlarge or create any warranty. Nothing contained herein is to be construed as permission or as a recommendation to infringe any patent.

Contents

Introduction & General Information for all Installations	
Introduction	2
Characteristics of Fabric Forms	3
Fine Aggregate Concrete Properties and Requirements	4
Site Preparation	6
Filter Fabric	6
HYDROTEX™ Linings and Mats	
Types of Concrete Linings and Mats	8
Typical Dimensions & Property Requirements	10
HYDROTEX Fabric Form Panels	12
Ordering	
Shop and Layout Drawings	
Proper Storage and Handling	
Contraction	
Factory Sewn Seams	
Baffles	
Irregular Panels	
Weep Tubes	
High Strength Cabling (for Articulating Block Mat)	
Requirements for Installing and Anchoring	18
Installation of HYDROTEX Linings and Mats	20
Equipment and Tools	
Sequence of Installation	
Sequence of Fine Aggregate Pumping	
Special Considerations	
HYDROCAST™ Armor Units	
General Information	32
Ordering Fabric Forms	
Unfilled Width/Length to filled Thickness & Width/Length	
Filled Form Volume	
Proper Storage and Handling	
Contraction	
Installation	37
Equipment and Tools	
Sequence of Installation	
Sequence of Fine Aggregate Pumping	
Special Considerations	
Appendices	43

Geostar Corporation
53 Perimeter Center East, Suite 250
Atlanta, Georgia 30346 (USA)
Tel: 1.800.253.0561 or 770.399.5051
Fax: 770.394.5999
<http://www.geostarcorporation.com>
e-mail: info@geostarcorporation.com

Introduction & General Information

Introduction

HYDROTEX™ brand fabric forms, manufactured by Geostar Corporation, are used to construct a wide range of concrete-filled systems that provide outstanding performance in erosion control, scour protection and repair, foundation, environmental and marine construction applications. The fabric forms are constructed of woven, double-layer, synthetic fabric. HYDROTEX linings and mats and HYDROCAST™ Armor Units are installed by positioning fabric forms over the areas to be protected and then pumping high-strength, fine aggregate concrete (structural grout) into the forms. The fabric forms can be placed and filled either underwater or in-the-dry. The high-strength, fine aggregate concrete is used in place of conventional concrete because of its pumpability, high-strength, impermeability, and absorption resistance.

HYDROTEX linings and mats and HYDROCAST Armor Units are used to protect canals, channels, culverts, dams, dikes, embankments, bridge piers, spillways, underwater pipelines, and other hydraulic and marine structures from the forces of flowing water and wave action. HYDROTEX Linings and Mats are also used to protect geomembranes and geosynthetic-clay liners from mechanical damage in landfills, reservoirs, sewage lagoons, ash pits, cooling ponds, and other containment, capping and environmental applications.

In addition to significant performance advantages, HYDROTEX fabric-formed concrete is economical to install. It eliminates the need for heavy equipment, steel reinforcement, and forming and stripping of conventional concrete forms. It generally does not require specialized labor or dewatering of the job site prior to installation.

This manual is designed as a guideline for the construction and quality control for HYDROTEX fabric-formed concrete systems. Prior to the delivery of materials to the job site, its contents should be thoroughly reviewed by those given the responsibility for design, installation and inspection.

The contents of this manual are only general guidelines and do not relieve the contractor of the responsibility to adhere to the Contract Drawings and Specifications. It is recommended that the Engineer of Record review these guidelines and specify any additional, project-specific installation procedures he considers necessary.

General Characteristics of Fabric Forms for HYDROTEX Linings and Mats and HYDROCAST Armor Units

HYDROTEX fabric forms are constructed of high-strength, synthetic yarns formed into woven, double-layer fabrics. Textured yarns comprise a minimum of 50% of the fabric weight for improved adhesion to fine aggregate concrete and better filtration characteristics. The yarns are woven into a network such that the yarns retain their dimensional stability relative to each other, including at the fabric selvages (edges). The selvage edges of the top and bottom layers of fabric are reinforced for a width of 1.35 inches (35 mm) by adding at least 6 warp yarns to the selvage construction. The reinforced selvage edges provide superior strength to sewn seams used in the fabrication of fabric forms.

The fabric forms are designed to serve as filters as well as concrete forms with a permeability selected to permit expulsion of excess concrete mixing water while retaining the cement solids. The fabric forms are resistant to alkalis, acids, organic solvents, and biological organisms.

After the fabric forms are woven and inspected, mill width rolls of fabric are factory assembled either into panels designed to fit project dimensions and topography or into forms of specified dimensions.

The designs of the fabric forms and their woven construction provide HYDROTEX fabric forms with a range of important benefits including:

High Strength, enabling the fabric forms to perform effectively under concrete pumping pressure;

High Elongation, to resist tear and puncture failure and to reduce form contraction;

Excellent permeability, to expel excess mixing water;

Lightweight, for ease of installation; and

Uniformity in dimensions, to assure consistent performance characteristics.

The fabric forms are designed to adhere to the fine aggregate concrete fill. Though it is assumed that the top layer of the fabric form may eventually be lost to abrasion and ultraviolet degradation, the bottom layer is expected to last indefinitely and to provide a low modulus tensile reinforcement.

There are two primary types of HYDROTEX fabric-formed concrete systems - HYDROTEX Linings and Mats and HYDROCAST Armor Units.

Fine Aggregate Concrete

Fine aggregate concrete consists of a mixture of Portland cement, fine aggregate (sand) and water, so proportioned and mixed as to provide a pumpable fine aggregate concrete.

Fine aggregate concrete has a typical mix water/cement ratio of 0.65 to 0.75. The pumping of fine aggregate concrete into the fabric forms causes a reduction in the water content by filtering excess mixing water through the permeable fabric. The reduction of mixing water substantially improves the water/cement ratio of the in-place fine aggregate concrete thereby increasing its strength and durability.

With a typical loss of approximately 15% of the total mixing water, 27 ft³ (or 1.0 m³) of pumpable fine aggregate concrete will reduce to approximately 25 ft³ (0.93 m³) of hardened concrete. The mixing water reduction will also result in an increase of approximately 8% in the sand and cement per cubic yard (m³) of concrete. The range of fine aggregate concrete mix proportions provided in Table 1.0 has been developed under a variety of field conditions.

Air Entrainment

Mixes designed with 5% to 8% air content will improve the pumpability of the fine aggregate concrete and the freeze-thaw resistance of the hardened concrete.

Admixtures

Pozzolan grade fly ash may be substituted for up to 35% of the cement as an aid to pumpability. (The pumpability of fine aggregate concrete mixes containing coarse sand is improved by the addition of fly ash.)

Grout fluidifier, water reducing or set time controlling agents may be used as recommended by their manufacturers to improve the pumpability and set time of the fine aggregate concrete.

Ready-mix

Fine aggregate concrete should be pre-mixed at a concrete batch plant and delivered by ready-mix trucks to the job site. *If a continuous supply of concrete can not be assured a reserve of concrete should be maintained in a holding hopper equipped with an agitator.*

The consistency of the fine aggregate concrete delivered to the job site should be maintained in the 9-11 second range when passed through the 0.75 inch (19 mm) orifice of the standard flow cone that is described in ASTM D 6449 (Fig. 1). *Tests utilizing a concrete slump cone are not appropriate.*

Components:

Portland cement should conform to ASTM C 150, Type I or II.

Fine aggregate should conform to ASTM C 33, except as to grading. Aggregate grading should be reasonably consistent and should not exceed the maximum size which can be conveniently handled with available pumping equipment.

Water for mixing should be clean and free from injurious amounts of oil, alkali, organic matter or other deleterious substances.

Pozzolan, if used, should conform to ASTM C 618, Class C, F or N.

Plasticizing and air entraining admixtures, if used, should conform to ASTM C 494 and ASTM C 260, respectively.

Table 1.0 Typical Range of Mix Proportions		
Material	Mix Proportions lb/yd ³ (kg/m ³)	After Placement Mix Proportions lb/yd ³ (kg/m ³)
Cement	750-850 (445-505)	805-915 (475-540)
Sand	2120-2030 (1255-1205)	2290-2190 (1355-1295)
Water	540-555 (320-325)	460-470 (270-275)
Air	As Required	As Required



Figure 1

Compression Testing of Fine Aggregate Concrete:

The fine aggregate concrete mix should exhibit the physical requirements of Table 2.0 at 28 days, when made and tested in accordance with ASTM C 31 and 39.

Some specifications require that the contractor prepare test cylinders cast in fabric tubes (test socks) as well as concrete cylinders cast in conventional impermeable molds.

The average compression strength of the concrete cylinders cast in fabric tubes should be at least 10% higher in 7 days than that of companion concrete cylinders made in accordance with ASTM C 31, and not less than 2,500 psi at 28 days.

Preparation of Fabric Tubes:

Fabric formed cylinders are prepared by attaching a 5.5 inch (140 mm) diameter (to allow for fabric stretching of approximately 5 to 10 percent) by 30 inch (762 mm) long fabric tube to a regulator cap (Fig. 27) and filling it with fine aggregate concrete, holding an injection pressure of approximately 10 psi (69 kPa) on the fluid concrete for a period of 10 minutes. A 12 inch (304 mm) long section is cut from the middle of the hardened specimen and capped and tested in the normal manner, with customary correction being applied for the slightly non-standard diameter.

Regulator Caps and fabric tubes are available from Geostar Corporation.

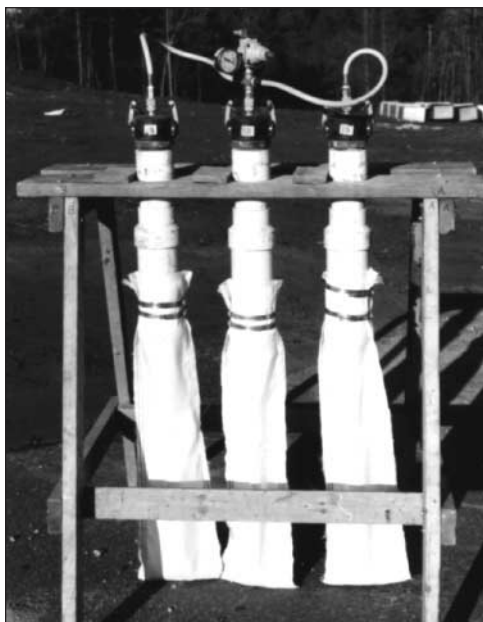

Figure 2

Pumpability

The fine aggregate concrete mix which is used to fill fabric forms is very fluid compared to a conventional mix (see Table 2.0). A conventional concrete mix has a 4 to 6 inch (100 to 150 mm) slump. However, as the fabric form is filled the excess mixing water in the pumped mix is rapidly expelled through the water-permeable fabric form, resulting in the pumped mix ratio of approximately 0.7 being reduced to a more typical ratio of 0.5. Within thirty minutes after placement, the consistency of the fine aggregate concrete within the fabric forms is that of a very low slump concrete.

Strength and Durability

Fabric formed fine aggregate concrete possesses superior physical properties. The compressive strength of fine aggregate concrete pumped into fabric forms is typically 1.5 to 1.75 times greater than companion samples taken from conventional concrete test cylinders. In addition, the fine aggregate concrete has less than 5% water absorption. This combined with a “case hardening” effect produces a concrete that is abrasion resistant, durable under freeze thaw action, resistant to “break up” caused by thermal cracking, highly impermeable, and resistant to acid, alkali, salt, organic solvents, biological organisms and petrochemicals. It is equivalent to a rich conventional concrete mix placed at an extremely low water/cement ratio. The “case hardening” effect is a result of a higher percentage of the cement in the cement-rich, fine aggregate concrete mix being drawn to the surface of the fabric forms by the expelled excess mixing water.

The higher compressive strength and “case hardening” achieved by the fine aggregate concrete permits concrete linings, mats and armor units to be constructed without reinforcement steel.

Environmental Compatibility

When fine aggregate concrete is pumped into the fabric forms an average of 0.25% of the cement content (with a maximum of 0.5%) is lost through the fabric forms, or the equivalent of approximately 2000 g of cement to a cubic yard (2,600 g/m³) of concrete pumped. The addition of 40 g of cement to a cubic yard (50 g/m³) of water will raise the pH value of water approximately 1.0. This should fall well within the nominal pH range (7.0 to 9.5) of potable water.

The following procedures, should assure that the rise in pH during fine aggregate concrete pumping of fabric formed linings, mats or armor units will not exceed 1.0:

- In stagnant water, the total volume of water must be at least 50 times the volume of fine aggregate concrete pumped.
- In flowing water, the rate of water flow in cubic yards per minute (m³/min) must exceed the rate of fine aggregate concrete pumped in cubic yards per hour (m³/hr).

Table 2.0 Physical Requirements			
Minimum Required Compressive Strength of Concrete psi (MPa)		Maximum Water Absorption Requirements lb/ft ³ (kg/m ³) Weight Classification - Oven-Dry Weight of Concrete, lb/ft ³ (kg/m ³)	
Average of Three Tests	Individual Test	105 (1682) to less than 125 (2002)	125 (2002) or more
2,000 (27.6)	1,400 (24.1)	10 (203)	8 (160)

Site Preparation

Standard excavating, grading and compaction equipment should be used to grade and compact the area to be protected and to excavate anchor, flank and toe trenches and aprons. *Specific information on the excavation of trenches is located on page 16 of this manual.*

The areas where the fabric forms are to be placed should be constructed to the lines and grades shown on the Contract Drawings. Where such areas are below the allowable grades, they should be brought to grade by placing compacted layers of select material. Vegetation and obstructions, such as roots and projecting stones, should be removed. Unsuitable soils should be removed and replaced with select material and compacted according to Contract Specifications. *Failure to do so may cause the fabric formed concrete linings, mats or armor units to bridge thus leaving a void beneath the structure.*

Draglines or bulldozers should generally be used for excavation and rough grading of the areas; however, they are not suitable for fine grading. Fine grading should be done with a hydraulic backhoe, grader or similar equipment. In most cases the contractor should be prepared to dress the areas with hand tools prior to placing the fabric forms. If an underwater dredge is used, the dredge operator must avoid overcutting or the cutting of stepped or scalloped slopes, particularly in cohesive soils.

Whenever the concrete linings, mats or armor units extend partially or entirely underwater, it will be necessary to perform underwater inspection and to dress the areas with hand tools prior to placement of the fabric forms. Stepped or scalloped slopes should be leveled first by dragging a steel beam or channel over the slope. *Underwater installation may be facilitated if a leveling course of granular material is placed and dressed prior to placement of the fabric forms.*

Filter Fabric (Geotextiles)

Geotextile filter fabric is often used under fabric-formed concrete linings and mats and concrete armor units (Fig. 3). The filter fabric is a permeable sheet of woven or nonwoven fabric selected in accordance to the gradation and permeability of the subsoils. The filter fabric must have opening sizes small enough to prevent soil from passing through and be permeable enough to allow the required flow of water. The filter fabric should conform to the minimum physical requirements shown in Table 3.0. Filter fabric should be protected from exposure to direct sunlight.

Filter Fabric Installation

If called for in the Contract Drawings and Specifications, filter fabric should be placed over the graded and compacted areas. The filter fabric should be placed loosely but without wrinkles or folds. Filter fabric sheets should be held in position by ballasting with sandbags or using "U"-shaped staples. Filter fabric placement should proceed concrete lining, mat or armor unit placement by no more than 2,000 ft² (200 m²).

As placement of the fabric formed concrete linings, mats or armor units proceeds, the filter fabric should be secured at toes of slopes and buried at crowns of slopes and flank

Slope Stability:

Fabric-formed linings, mats and armor units provide concrete protection for earthen structures subject to flowing water, waves and wind.

*Though fabric-formed concrete can be installed on slopes steeper than those suitable for quarry stone or precast concrete blocks or for compacted soil or soil cement construction, **fabric-formed concrete linings and mats are not designed to improve slope stability.** Their inherent weights are selected for the purposes of hydraulic stability and are not to be considered sufficient to impart stability to slopes subject to rotational, global or sliding failure or where severe consolidation of the subgrade is anticipated.*

Fabric-formed armor units, however, may be designed as heavy weight units, and can be used to construct structures that act as gravity retention structures for steep slopes subject to failure.

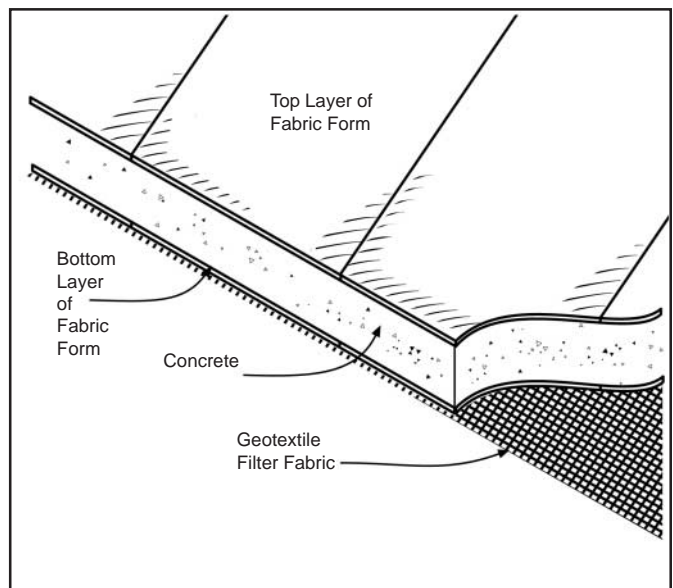

Figure 3

Foot traffic:

Foot traffic on the prepared areas should be at a minimum. Should traffic be unavoidable, the contractor should place board walks along the finished graded areas. This will reduce the amount of hand dressing required to remove footprints. Heavily trafficked areas will reflect through the installed fabric-formed concrete linings or mats as irregularities in the surface.

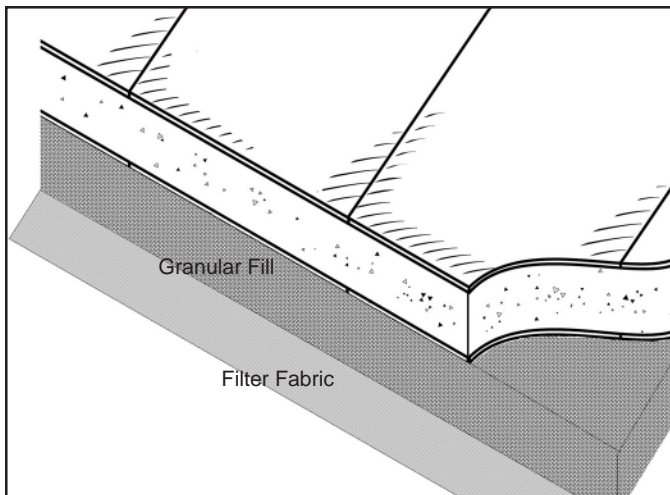

Figure 4

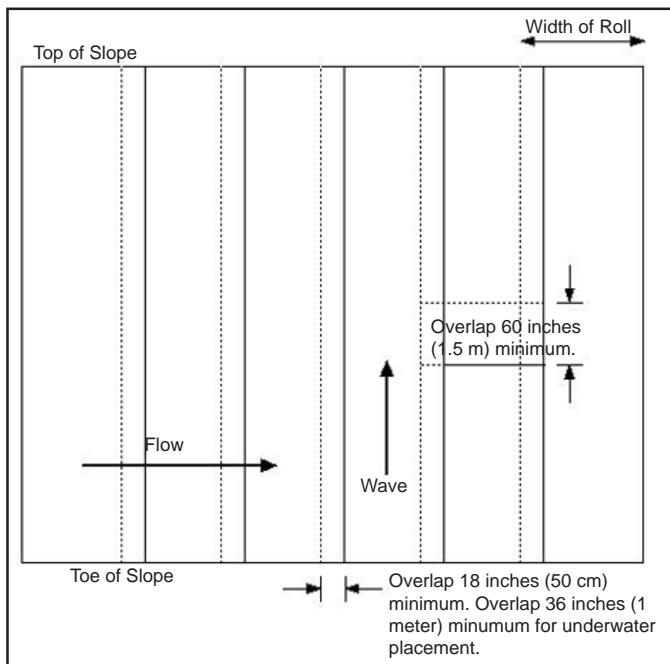

Figure 5

Manufacturer's Certification: Prior to accepting delivery from the supplier, verify that the filter fabric satisfies all provisions of the Contract Specifications and that mill certificates have been provided.

Table 3.0 - Filter Fabric ^{1,2} Property Requirements			
Property	Test Method	Units	Values
Grab Tensile Strength	ASTM D 4632	lbf (N)	90 (400)
Elongation at Break	ASTM D 4632	%	15
Trapezoidal Tear Strength	ASTM D 4533	lbf (N)	30 (130)
Permittivity	ASTM D 4491	sec ⁻¹	0.5

Notes:

1. Conformance of filter fabrics to specification property requirements shall be based on ASTM D 4759, "Practice for Determining the Specification Conformance of Geotextiles."
2. All numerical values represent minimum average roll values (i.e., average of test results from any sample roll in a lot shall meet or exceed the minimum values). Lots shall be sampled according to ASTM D 4354, "Practice for Sampling of Geosynthetics for Testing."

trenches. Care must be taken when placing filter fabric to assure that the placement method does not damage the fabric.

When installing fabric form linings, mats and armor units on silts, sandy silts or fine sand, the specifications may call for the addition of a sublayer. The sublayer serves to prevent serious downslope migration of the subsoil particles. Sublayers should be constructed of granular material.

Granular sublayers, as shown in Figure 4, are placed between the filter fabric and the fabric form. They generally have a thickness of between 3 and 9 inches (8-20 mm).

Filter Fabric Joints

Lapped Joints

Lapped joints are easy to install but require additional filter fabric. The sheets of filter fabric should be placed as shown in Figure 5, with the principal direction (roll length or warp direction) running down the slope. Overlapping of fabric sheets should adhere to the Contract Drawings and Specifications but be at least 18 inches (50 mm) but more generally 36 inches (1 meter), especially when laying underwater. Generally, sheets are overlapped parallel to the slope, as shown in Figure 5, to retain any soil particles migrating along the bank. If soil migration is unlikely or the fabric is being set in flowing water or current the overlap should be reversed.

Seamed Joints

Sewn seams are the most reliable method of joining filter fabric sheets and require the least amount of fabric. Seams are made on-site using portable, handheld, sewing machines and nylon or polyester sewing thread. Generally, a prayer (flat) seam with a U.S. Federal Standard Type 101 (Fig. 6) stitch is the most suitable.

Combining Lapped and Seamed Joints
Most filter fabric suppliers will factory-sew filter fabric rolls together to form multiple roll width sheets. The contractor may lap the joints of these large sheets thus taking advantage of the ease of lapped joints and the reliability of sewn seams.

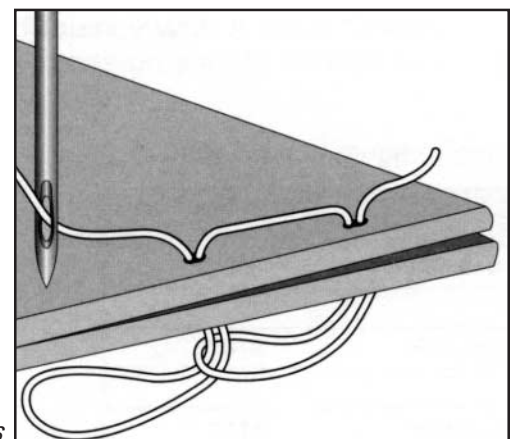

Figure 6

HYDROTEX Linings and Mats

Types of Linings and Mats

HYDROTEX linings and mats are available in five basic styles: Filter Point (FP), Filter Band™ (FB), Uniform Section (US), Enviromat™ (EL & EB), and Articulating Block (AB). Additionally, special fabric forms may be woven to suit the specific requirements of a project. Each is designed with the required strength, stability and permeability properties required to assure the pumping in-place of a durable and abrasion resistant concrete lining or mat system with specific thickness, weight and hydraulic characteristics. Forms of different styles and thickness can be incorporated in the same installation. Table 4.0 provides typical dimensions, weights and volumes for the range of standard HYDROTEX linings and mats. Table 5.0 provides property requirements for the fabric used in form construction.

Filter Point (FP) Linings

Filter Point Linings (Fig. 7) with filtering points (drains) provide erosion resistant, permeable concrete linings for ditches, channels, canals, streams, rivers, ponds, lakes, reservoirs, marinas, and protected port and harbor areas. Filter Point Linings have a cobbled surface and a relatively high coefficient of hydraulic friction in order to achieve lower flow velocities and to reduce wave run-up. The filter points provide for the relief of hydrostatic uplift pressures, increasing the system's stability.

Filter Point Linings were the first type of fabric form for concrete developed. In 1965, a Dutch patent was issued for "fabric-formed slope paving." The form suggested by this patent was later refined to create the first "filter point" lining.

Filter Band™ (FB) Linings

Filter Band Linings (Fig. 8) are similar to Filter Point, providing an effective and highly permeable concrete lining that resists erosive forces. Filter Band differs from Filter Point in that the form creates interconnected, tubular concrete elements that are separated by large, interwoven filter bands. The filter bands provide for greater reduction of uplift pressures than Filter Point Linings. Also, the biaxial alignment of the tubular elements creates two directionally-determined coefficients of hydraulic friction. As a result, Filter Band achieves greater reduction of flow velocity or wave energy than Filter Point.

Filter Band concrete linings are specified in situations similar to those for which Filter Point might be specified, but which also require greater relief of uplift pressures, higher reduction of flow velocities, or greater reduction of wave run up.

Filter Points and Filter Bands:

Filter points and filter bands define the locations at which the two layers of fabric form are interwoven to form water permeable drains. The interweaving of the two layers results in an area of double density, higher strength, single layer fabric. The weave of the fabric at the center of these drain locations incorporates a "Twill Weave" in order to "open up the fabric" and permit the flow of ground water through the drain while retaining soil particles. A twill is a weave characterized by diagonally-oriented yarns woven over then under more than one yarn. Figure 9 illustrates the construction of a filter point with a twill weave center designed to function as a drain as well as a filter. The cross shaped design reduces applied stress to the filter point during concrete pumping. Filter bands are also constructed with a twill weave center.

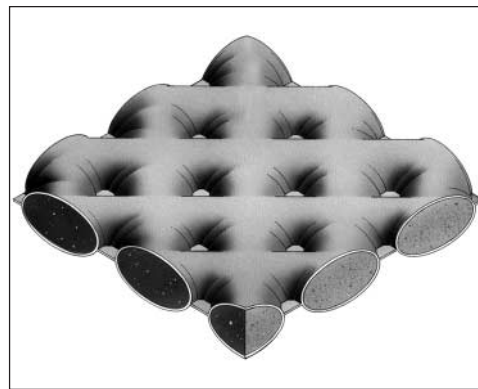

Figure 7



Figure 8

Manufacturer's Certification:

The manufacturer of the fabric forms should submit a manufacturer's certificate stating that the supplied fabric forms meet the criteria of the manufacturer's specifications, as measured in full accordance with the test methods and standards referenced. The certificates should include the following information about each fabric form shipment:

- *Manufacturer's name and current address*
- *Full product name*
- *Style and product code number*
- *Form number(s)*
- *Polymer types*
- *Manufacturer's certification statement*

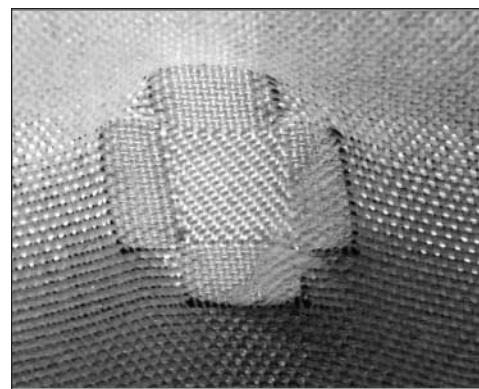

Figure 9

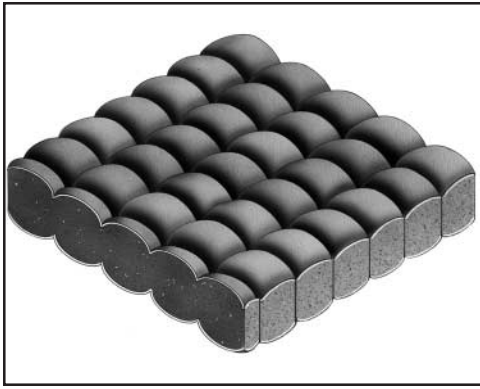

Figure 10

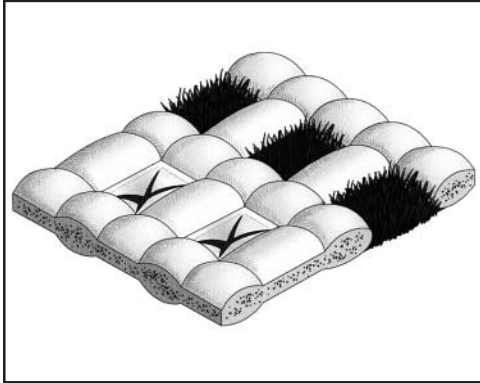

Figure 11

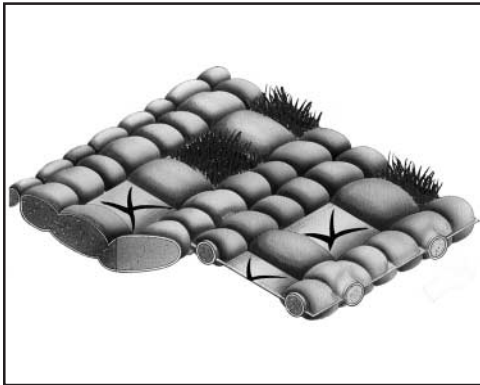

Figure 12

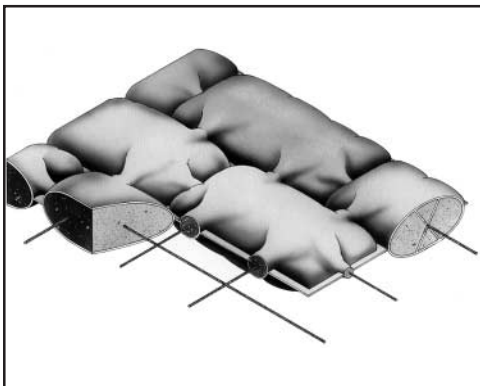

Figure 13

Uniform Section (US) Linings

Uniform Section Linings (Fig. 10) are similar to traditional concrete slope paving. They create a solid, high quality concrete lining with a relatively low hydraulic resistance and uniform cross section. These linings are used to reduce the infiltration or exfiltration of aggressive waste and chemical fluids into or out of open channels and basins. They are also used to reduce exfiltration in arid regions where open channels and basins require watertight linings.

Uniform Section Linings are resistant to leachate and most chemicals. They protect geosynthetic liners from mechanical damage, exposure to UV light, and freeze-thaw cycles. These self-supporting, high strength linings permit construction on steep side slopes and replace the conventional use of clay or sand as liner protection. Placement of the forms and concrete filling can be performed without the use of equipment on the liner. The tensile strength and abrasion resistance of the fabric protect the liner from the pumped concrete.

Enviromat™ (EL and EB) Linings

Enviromat Linings EL (Fig. 11) and EB (Fig. 12) are installed to provide protection against periodic high flows. After installation, vegetation can be planted within the open structure of the lining to create a more natural appearance. Enviromat Linings are used in drainage ditches and on the upper slopes of channels, canals, lakes, reservoirs, rivers, and other water courses as well as for embankments subject to heavy run-off.

Enviromat Linings are comprised of concrete-filled elements and unfilled areas that allow for the establishment of vegetation. Once the concrete sets, the defined unfilled and interwoven areas are opened by cutting the fabric and are planted or are filled with topsoil and seeded. Within a growing season a vegetated cover will normally extend over the lining, resulting in an erosion control system with the hydraulic, ecological and aesthetic features desired. EL linings have a greater open area (~35%) than EB (~20%), so a vegetated cover will be established more rapidly. However, EB linings are designed to articulate and are more tolerant of uneven settlement after installation.

Articulating Block (AB) Mats

Articulating Block Mats (Fig. 13) form cable-reinforced concrete block mattresses that resist erosive forces. They are often constructed where a revetment is exposed to frontal attack by wave action. AB Mats are typically used to protect coastlines, canals, rivers, lakes, reservoirs, underwater pipelines, bridge piers, and other marine structures from propeller wash, ship wakes, wind waves, currents, and high velocity flows. They are also used in environmental construction for landfill caps, down chutes, and collector channels.

The AB fabric form consists of a series of compartments linked by an interwoven perimeter. Grout ducts interconnect the compartments, and high strength revetment cables are installed between and through the compartments and grout ducts. Once filled, the AB Mats become a mattress of pillow-shaped, rectangular concrete blocks. The interwoven perimeters between the blocks serve as hinges to permit articulation. The cables remain embedded in the concrete blocks to link the blocks together and facilitate articulation.

Table 4.0 - Linings and Mats, Typical Dimensions, Weight and Volume

Filter Point	FP220	FP400	FP600	FP800	FP1000	FP1200
Average Thickness, inches (mm)	2.2 (56)	4.0 (102)	6.0 (152)	8.0 (203)	10.0 (254)	12.0 (305)
Mass Per Unit Area, lb/ft ² (kg/m ²)	25 (121)	45 (220)	68 (330)	90 (440)	113 (550)	135 (661)
Filter Point Spacing, inches (mm)	5.0 (127)	8.0 (203)	10.0 (254)	12.0 (305)	14.0 (356)	16.0 (406)
Area per Filter Point, in ² (cm ²)	2.0 (12.9)	2.0 (12.9)	6.3 (40.7)	6.3 (40.7)	12.2 (78.7)	12.2 (78.7)
Perimeter per Filter Point, inches (mm)	6.5 (165)	6.5 (165)	11 (279)	11 (279)	15 (381)	15 (381)
Concrete Coverage, ft ² /yd ³ (m ² /m ³)	136 (16.6)	75 (9.1)	50 (6.1)	38 (4.6)	30 (3.6)	25 (3.0)
Shear Resistance, lb/ft ² (kg/m ²)	11 (54)	20 (98)	30 (146)	40 (195)	50 (244)	60 (293)

Filter Band™	FB400	FB800	FB1200
Average Thickness, inches (mm)	4.0 (102)	8.0 (203)	12.0 (305)
Mass Per Unit Area, lb/ft ² (kg/m ²)	45 (220)	90 (440)	135 (661)
Filter Band Spacing, inches (mm)	8.0 (203)	16.0 (406)	24.0 (609)
Concrete Coverage, ft ² /yd ³ (m ² /m ³)	75 (9.1)	38 (4.6)	25 (3.0)
Shear Resistance, lb/ft ² (kg/m ²)	15 (73)	29 (142)	44 (215)

Uniform Section	US300	US400	US600	US800	US1000
Average Thickness, in (mm)	3.0 (76)	4.0 (102)	6.0 (152)	8.0 (203)	10.0 (254)
Mass Per Unit Area, lb/ft ² (kg/m ²)	34 (165)	45 (220)	68 (330)	90 (440)	113 (550)
Drop Point Spacing, in (mm)	3 x 3 (76 x 76)	3 x 4 (76 x 102)	3 x 6 (76 x 152)	4.5 x 7.5 (114 x 191)	4.5 x 9 (114 x 229)
Concrete Coverage, ft ² /yd ³ (m ² /m ³)	100 (12.1)	75 (9.1)	50 (6.1)	38 (4.6)	30 (3.6)
Shear Resistance, lb/ft ² (kg/m ²)	14 (68)	18 (88)	28 (137)	37 (181)	46 (224)

Enviromat	EL250	EL400
Average Thickness, inches (mm)	2.5 (64)	4 (102)
Mass Per Unit Area, lb/ft ² (kg/m ²)	28 (138)	45 (220)
Open (vegetated) Area, %	35	35
Concrete Coverage, ft ² /yd ³ (m ² /m ³)	120 (14.6)	75 (9.1)
Shear Resistance, lb/ft ² (kg/m ²)	10 (49)	16 (78)

Enviromat	EB300	EB500
Average Thickness, inches (mm)	3.0 (76)	5.0 (127)
Mass Per Unit Area, lb/ft ² (kg/m ²)	34 (165)	56 (275)
Open (vegetated) Area, %	20	20
Concrete Coverage, ft ² /yd ³ (m ² /m ³)	100 (12.1)	60 (7.3)
Shear Resistance, lb/ft ² (kg/m ²)	12 (59)	20 (98)

Articulating Block	AB400	AB600	AB800	AB1000	AB1200
Average Thickness, in (mm)	4.0 (102)	6.0 (152)	8.0 (203)	10 (254)	12 (305)
Mass Per Unit Area, lb/ft ² (kg/m ²)	45 (220)	68 (330)	90 (440)	113 (550)	135 (661)
Mass per Block, lb (kg)	88 (39.8)	188 (85.2)	325 (148)	563 (255)	844 (382)
Nominal Block Dimensions, in (mm)	20 x 14 (508 x 356)	20 x 20 (508 x 508)	20 x 26 (508 x 660)	30 x 24 (762 x 610)	30 x 30 (762 x 762)
Concrete Coverage, ft ² /yd ³ (m ² /m ³)	75 (9.1)	50 (6.1)	38 (4.6)	30 (3.6)	25 (3.0)
Shear Resistance, lb/ft ² (kg/m ²)	26 (127)	39 (190)	52 (254)	65 (317)	78 (381)

Note: Values shown are typical and will vary with weight of concrete and field conditions.

Physical Requirements: *At the time of delivery to the job site, the fabric used in form construction should conform to the minimum property requirements of Table 5.0. All fabric forms should be free of rips or defects that would interfere with the proper placing of the fabric forms or significantly impair the strength or performance of the construction. Minor holes incidental to the usual method of manufacture or minor rips resulting from shipment and delivery or handling are not grounds for rejection. Small rips or holes are repaired by the contractor in the field by sewing.*

Table 5.0 - Property Requirements - Form Fabric^{1, 2}

Property	Test Method	Units	Values
Physical:			
Composition of Yarns			Nylon or polyester
Mass Per Unit Area (double-layer)	ASTM D 5261	oz/yd ² (g/m ²)	12 (403)
Thickness	ASTM D 5199	mils (mm)	25 (0.6)
Mill Width		in (m)	76 (1.92)
Mechanical:			
Wide-Width Strip Tensile Strength	- Machine	ASTM D 4595	lbf/in (kN/m)
	- Cross		lbf/in (kN/m)
Elongation at Break	- Machine	ASTM D 4595	%
	- Cross		%
Trapezoidal Tear Strength	- Machine	ASTM D 4533	lbf (N)
	- Cross		lbf (N)
Hydraulic:			
Apparent Opening Size (AOS)	ASTM D 4751	U.S. Standard Sieve (mm)	40 (0.425)
Flow Rate	ASTM D 4491	gal/min/ft ² (l/min/m ²)	90 (3665)
Flow Rate through Filter Point or Band (if applicable)	ASTM D 4491	gal/min/ft ² (l/min/m ²)	7 (285)

Notes:

1. Conformance of fabric to specification property requirements shall be based on ASTM D 4759, "Practice for Determining the Specification Conformance of Geotextiles."
2. All numerical values represent minimum average roll values (i.e., average of test results from any sample roll in a lot shall meet or exceed the minimum values). Lots shall be sampled according to ASTM D 4354, "Practice for Sampling of Geosynthetics for Testing."
3. Yarns used in fabric construction shall not contain partially oriented (POY), draw-textured, and/or staple yarns.

Fabric Form Panels

Fabric form mill rolls are factory assembled by sewing several mill widths of fabric forms side-to-side to form large panels. Mill width rolls of fabric forms are cut to the lengths required and their two layers of fabric separately sewn together, bottom layer to bottom layer and top layer to top layer, to form multiple mill width panels (Fig. 14). Site conditions and manpower and equipment resources at the job site will determine the maximum sizes of individual panels.

Ordering Fabric Form Panels

The ordering of fabric form panels should be done in advance of the start of the project, to allow time for the preparation, submittal and approval of layout and shop drawings. Project plans and specifications should be submitted to Geostar's technical support department. Trained technicians translate the site plans, grades, elevations, contours and construction details into CAD systems where they develop cost-effective take-offs and fabric-formed concrete shop and layout drawings, tailored to the project's design requirements. This design technique and CAD layout verification procedure will assure accurate dimensioning and material quantity takeoffs.

Shop and Layout Drawings

Fabric form panel shop drawings are plotted to scale and each panel is numbered. Figure 15 is a typical panel shop drawing. Baffle locations and the edges of the panel which are to be sewn or closed and which are unsewn or left open, for joining to adjacent panels, are clearly marked on each panel shop drawing. The fabric forms are dimensioned to include all aprons, overlaps, and anchor, flank or toe trenches and contraction factors. The forms are over-dimensioned, in both length and width, to make allowance for form contraction as they are filled with fine aggregate concrete. (Contraction factors are discussed on the following page.)

Layout drawings (Fig. 16) showing the field assembly of the fabric form panels for the entire project are prepared. The drawings identify each panel number, its location and sequence of installation, pertinent elevations and coordinates, direction of flow, anticipated water levels, and structures such as roads, curbs, bridges, intake and discharge pipes, culverts, ramps and other existing and future structures that may effect the placement of the fabric formed concrete linings, mats or armor units. In addition, lap joint locations are shown as well as notes regarding special field splicing operations, if required.

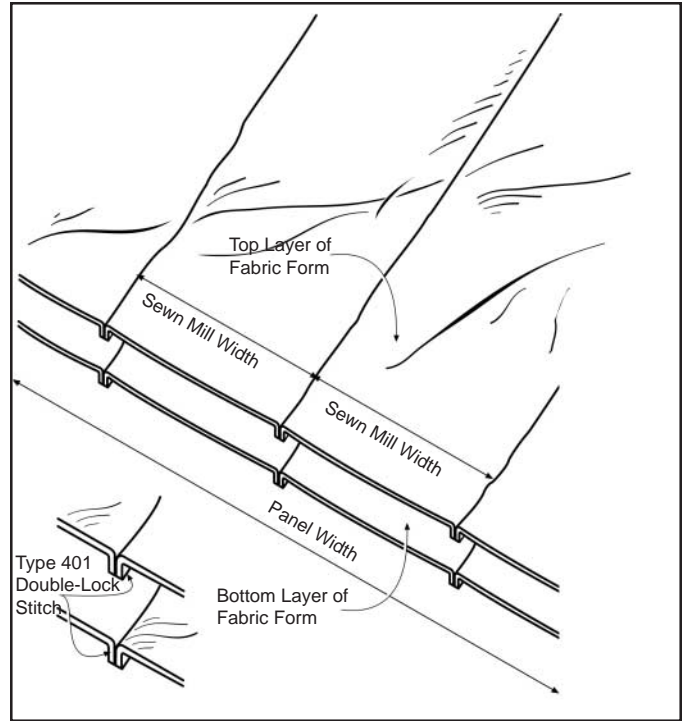

Figure 14

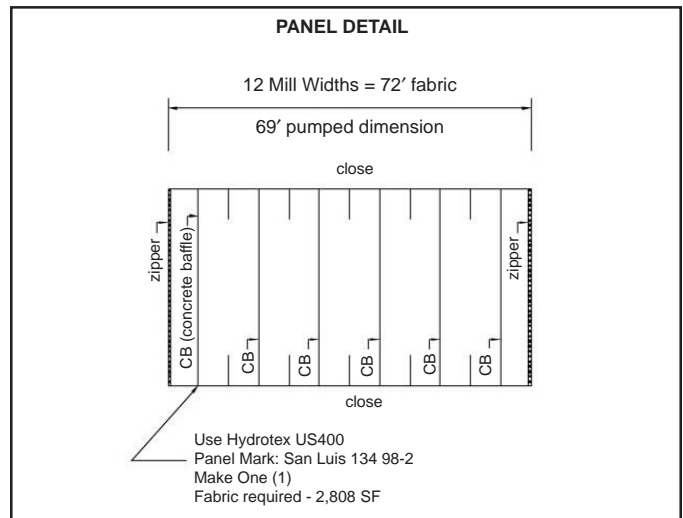

Figure 15

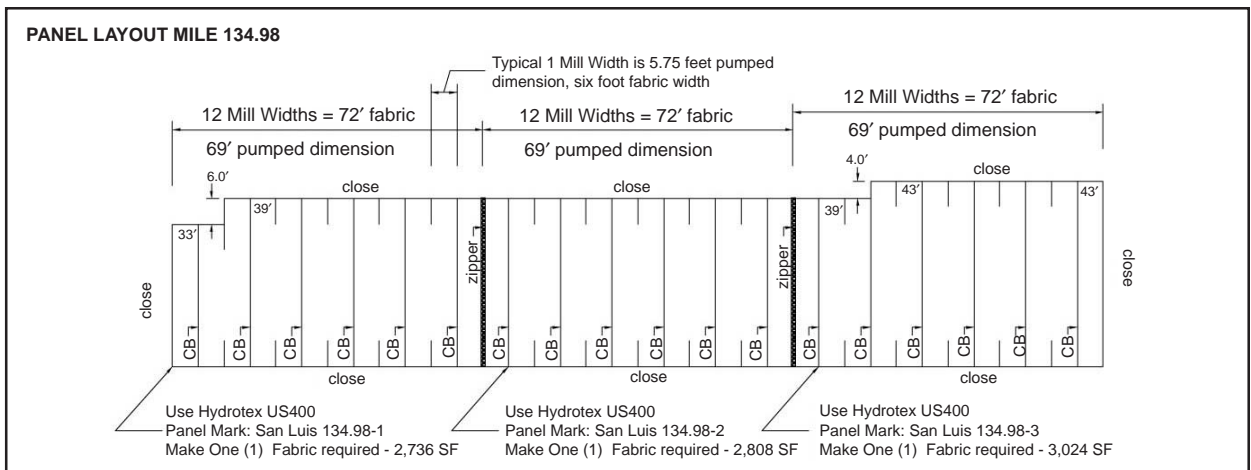

Figure 16



Figure 17

Minor changes in dimensions, grades, contours and field conditions from those shown on the contract drawings may be accommodated by fabric stretch or adjustment during field placement.

A submittal package which includes shop and layout drawings, a list of numbered fabric form panels, panel dimensions and areas, and a manufacturer's certification is assembled and forwarded to the contractor for submittal to the project engineer.

Upon the project engineer's approval of the submittal package, Geostar's manufacturing department commences panel fabrication and confirms the delivery schedule.

Proper Storage and Handling of Fabric Forms

Fabric forms are delivered at the job site in trailers or ocean containers. Fabric forms are stacked in a manner that assures ease of unloading. Standard 40 ft (12 m) long trailers or containers hold up to 215,000 ft² (20,000 m²) of fabric forms per load. Fabric forms are normally delivered to the site packaged in accordance with Table 6.0.

Rolls and panels of fabric forms are each wrapped in two layers of protective cover: the first layer (inner layer) is a waterproof, opaque, plastic cover the second (outer layer) is a woven, abrasion resistant, fabric cover (Fig. 17).

When fabric forms are to be inventoried at the job site, they should be kept dry and remain wrapped so that they are protected from the elements during storage and handling. If stored outdoors, they should be elevated and protected with a waterproof cover that is opaque to ultraviolet light. Care should be taken not to damage the fabric forms during unloading, storage and handling.

Note: *The contractor should unload the fabric forms by hand or with a forklift or similar equipment. When lifting rolls or panels of fabric forms make sure that workers have proper back support.*

Table 6.0 - Packaging of Fabric Form Rolls

Product	Filter Point (FP)	Filter Band (FB)	Uniform Section (US)	Enviromat (EL & EB)	Articulating Block (AB)
Roll Width, ft (m)	6.33 (1.92)	6.33 (1.92)	6.33 (1.92)	6.33 (1.92)	6.33 (1.92)
Roll Length, ft (m)	450 (137.2)	450 (137.2)	300 (91.5)	450 (137.2)	450 (137.2)
Gross Weight, lb (kg)	220 (100)	220 (100)	160 (72.7)	220 (100)	240 (109)
Area, ft ² (m ²)	2,848.5 (264.6)	2,848.5 (264.6)	1,899.0 (176.4)	2,848.5 (264.6)	2,848.5 (264.6)

Contraction of HYDROTEX linings and mats

Contraction factors are a function of site conditions and the fabric form lining or mat style. The definition of "contraction factor" is the length or width of fabric form required divided by the corresponding length or width of the area to be covered by the concrete lining or mat.

The contraction factors provided in Table 7.0 represent typical contraction factors developed by evaluating a large number of installations constructed over typical site conditions (Fig. 18). To use the contraction factors, measure the coverage area (including anchor, toe and flank trenches) and multiply by the contraction factor to obtain the dimensions of the form required.

Example Calculation: Calculate the quantity of Filter Point Fabric Form required for a 200 foot long by 33.2 foot wide mattress lining the drainage channel shown in Figure 19. The *length* of the panel spans the *width* of the channel to allow for more precise sizing. For simplicity in the example calculation, no allocation has been made for flank trenches in the calculation of the panel width.

Total Length of Panel

(spanning the width of the channel):

$$[2 (2.0 \text{ ft} + 1.5 \text{ ft}) + 2 ((2.5 \text{ ft})(\sin 26.6^\circ)^{-1}) + 15 \text{ ft}] = 33.2 \text{ ft (10.1 m)}$$

$$33.2 \text{ ft (10.1 m)} \times 1.1 = 36.5 \text{ ft (11.1 m)}$$

Total Width of Panel

(running along the length of the channel):

$$200 \text{ ft} \times 1.1 = 220 \text{ ft (67.1 m)}$$

Adjusting for mill widths multiples:

$$220 \text{ ft} / 6 \text{ ft} = 36.7 \text{ or } 37 \text{ mill widths}$$

$$37 \text{ mill widths} \times 6 \text{ ft} = 222 \text{ ft (67.7 m)}$$

Total Quantity of Fabric Form:

$$222 \text{ ft} \times 36.5 \text{ ft} = 8,103 \text{ ft}^2 (753.1 \text{ m}^2)$$

Note: Calculations should be done using the Mill Width and Mill Length factors given in Table 7.0. The Area factors are for rough estimating purposes only. Differing form geometries and the need to round up the width of the panels to mill width multiples can cause the area factors to be slightly inaccurate. In this example, 33.2 ft x 200 ft gives a coverage area of 6,640 ft². The actual panel area of 8,103 ft² is 1.22 times the coverage area.

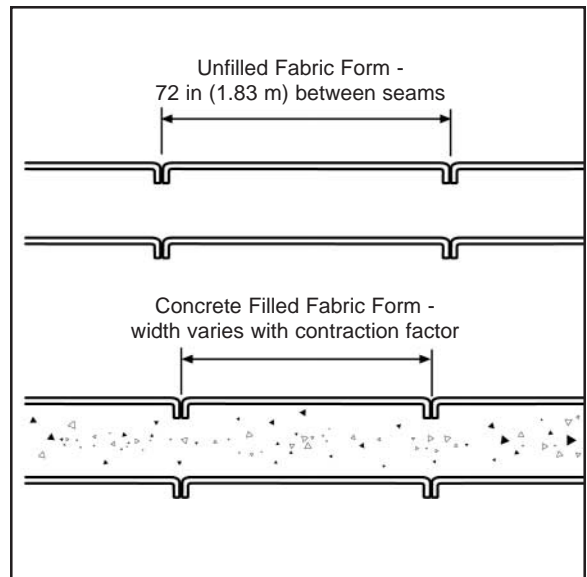

Figure 18

Notes:

The fabricated length dimensions of the fabric form panels are rounded up to the nearest one half foot (150 mm), except for Articulating Block Fabric Forms. Articulating Block Fabric Forms are rounded up to the next full compartment (block). The width dimensions of the panels are in mill width multiples of fabric form. Standard mill width is 72 in (183 mm). However, the width of the last panel in a section may be rounded up to the nearest half mill width.

Additional fabric may be required to allow for tailoring of panels to meet irregular site conditions. These factors range from two to ten percent.

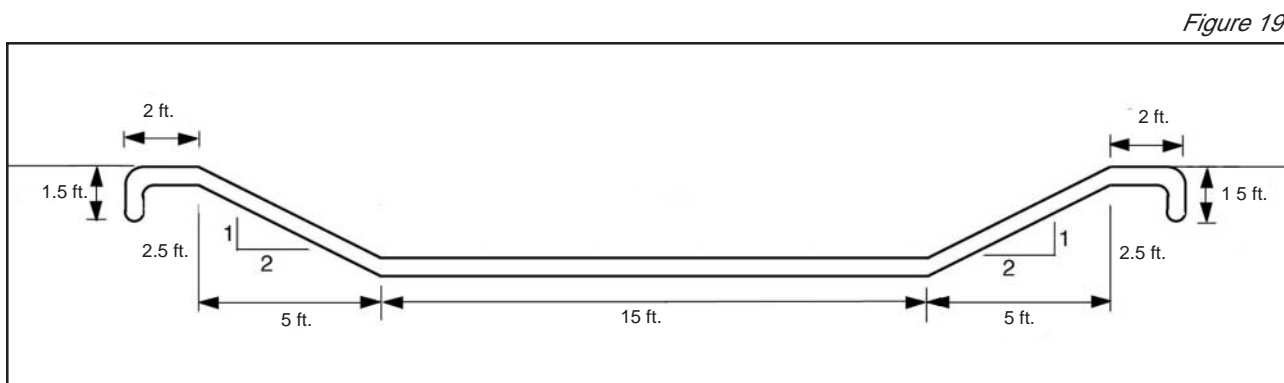

Figure 19

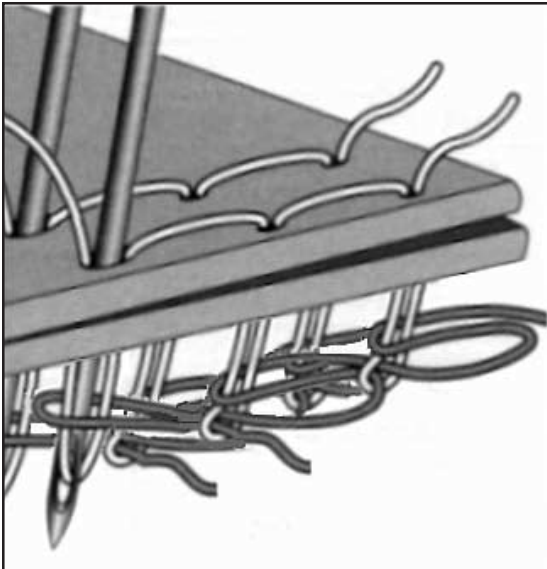

Figure 20

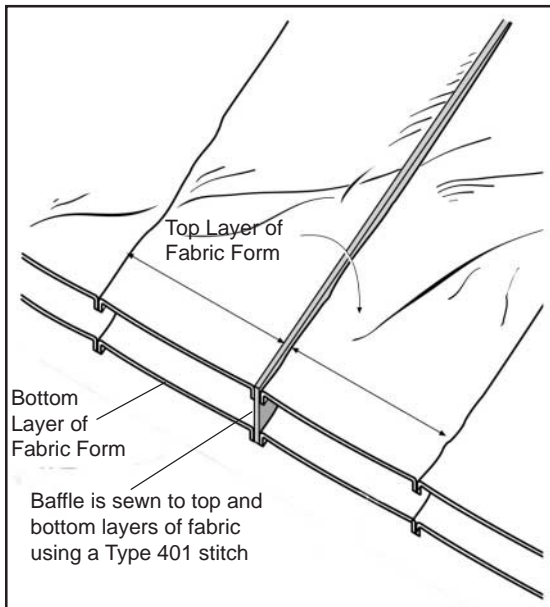

Figure 21

Factory Sewn Seams

All factory sewn seams are made with a double line of Type 401 double-lock stitches (Fig. 20) and are downward facing (Fig. 18). The downward facing seams provide a neat and continuous appearance in the finished fabric forms. All seams sewn in the factory shall be not less than 90 lbf/in (15.7 kN/m) when tested in accordance with ASTM D 4884. Thread used for seaming shall be nylon and/or polyester.

The fabric form panel's two layers of fabric are generally sewn closed along the panel's top and bottom edges (Fig. 15). The side edges of the panel are generally left open to enable field attachment of adjacent panels (Fig. 16). The contractor may request that zippers be attached to the top and bottom layers of fabric along the panel's open edges. The contractor attaches adjacent panels in the field by either sewing or zippering the open edges of fabric together.

Baffles

Baffles are installed at predetermined mill width intervals to regulate the lateral flow of fine aggregate concrete. The baffles are concrete stops made of nonwoven fabric. They extend from the top layer to the bottom layer of the fabric form at corresponding seams of adjacent mill widths (Fig. 21). The location of all baffles are specified on the shop drawings. Typically, baffles are installed every one to six mill widths apart, depending on the fabric form style, size and shape of the fabric form panel, and the project slope's steepness and length.

Irregular Panels

Non-rectangular fabric form panels are occasionally required to account for changes in slope elevations or length, to transverse around sharp curves and turns, and to fit around structures. (Standard rectangular panels may be "warped" around gradual curves or turns as described on page 23 of this manual.) When factory assembling irregular panels the lengths and offsets of individual mill widths of fabric form are dimensioned and cut to the nearest 0.5 ft (150 mm).

When Filter Point and Uniform Section panels are assembled to transverse around sharp curves or turns, panels are constructed with "mirror image" mill widths. Each of the panels will have one or more pairs of mill widths cut on a diagonal to the panel length. The matching sides of the mill widths are cut to obtain true angles and edges, then sewn together to form mitered seams. For Filter Band, Enviromat, and Articulating Block, please refer to page 25.

Table 7.0 - Typical Contraction Factors for HYDROTEX Linings and Mats

	Filter Point (FP)	Filter Band (FB)	Uniform Section (US)	Enviromat (EL)	Enviromat (EB)	Articulating Block (AB)
Mill Width	1.1	1.1	1.05	1.2	1.1	1.1
Mill Length	1.1	1.2	1.05	1.2	1.2	1.1
Area	1.21	1.32	1.1	1.44	1.32	1.21

Weep Tubes (for Uniform Section Linings)

Plastic weep tubes (drains) are pre-installed at designated locations, along the fabric forms, to relieve hydrostatic pressure (Fig. 22). The tubes have a flange at one end and a point at the other end of a 0.75 inch (19 mm) diameter barrel. The pointed end has four small holes that allow the passage of water but retain large soil particles. There is a flanged cap that is placed over the pointed end and locks in place. Weep tubes are available in lengths of 3, 4, 6, 8, and 10 inches (76, 102, 152, 203, and 254 mm) when measured between the assembled weep tubes flanges. The location of weep tubes, if required, are clearly marked on the fabric form panel shop drawings.

Weep tubes are assembled by forcing the pointed end of the weep tube through both the top and bottom layers of the fabric form and locking the flanged cap over the pointed end (Fig. 23). A small square of filter fabric can be placed over the in-place flanged cap and secured with a fastener (Fig. 24) or the fabric form can be placed over a continuous layer of filter fabric as shown in Figure 23. In either case the filter fabric should prevent fine soil particles from passing through the weep tube.

High-Strength Cable (for Articulating Block Mats)

High-strength cables should be constructed of high tenacity, low elongation, continuous filament polyester fibers. High-strength cables should have a core construction comprised of parallel fibers contained within an outer jacket or cover. The weight of the parallel fiber core should be 65 to 75 percent of the total weight of the cable. High-strength cables are available in a range of diameters and strengths (Table 8.0).

Table 9.0 provides the suggested high-strength polyester cable diameter for the range of Articulating Block Fabric Forms placed on slopes of different lengths. (AB 800, 1000, and 1200 should not be installed on slopes steeper than 1.5:1 except by experienced installers. Please contact Geostar Corporation for further technical assistance.)

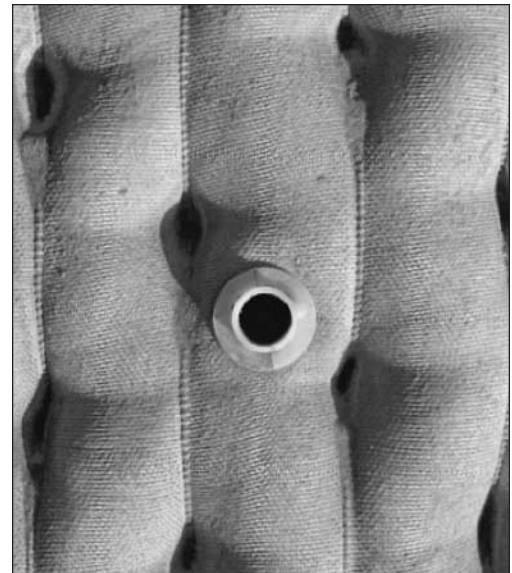

Figure 22

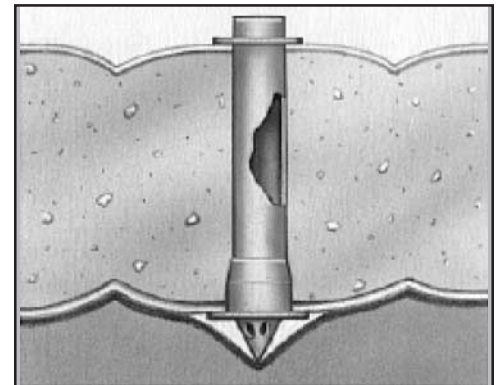

Figure 23

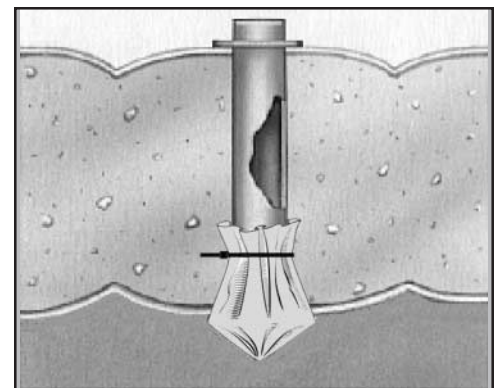

Figure 24

Table 8.0 - Nominal Dimensions, Strengths and Weights of High-Strength Polyester Cables

Cable Diameter, in (mm)	Weight Per 100 Linear Feet, lb (kg)	Average Breaking Strength, lbf (kN)	Maximum Allowable Working Load Per Cable, lbf (kN)
0.250 (6.35)	2.50 (1.13)	3,700 (16.47)	740 (3.29)
0.280 (7.11)	2.80 (1.27)	4,500 (20.03)	900 (4.00)
0.375 (9.53)	4.90 (2.22)	7,000 (31.15)	1,400 (6.23)
0.440 (11.2)	6.60 (2.99)	10,000 (44.50)	2,000 (8.90)
0.500 (12.7)	8.93 (4.05)	15,000 (66.75)	3,000 (13.35)
0.625 (15.9)	13.70 (6.22)	23,000 (102.35)	4,600 (20.47)

All dimensions and tensile strengths are average ± 5%.

Table 9.0 - High Strength Polyester Cable Selection Chart

Articulating Block Size	Slope	Slope Length, ft (m)								
		<20 (6.10)	30 (9.14)	40 (12.19)	50 (15.24)	60 (18.29)	70 (21.34)	80 (24.38)	90 (27.43)	100 (30.48)
		Average Breaking Strength of Polyester Cable, lbf (kN)								
AB400	5:1 - 2:1	3,700 (16.47)	3,700 (16.47)	3,700 (16.47)	3,700 (16.47)	3,700 (16.47)	3,700 (16.47)	3,700 (16.47)	3,700 (16.47)	3,700 (16.47)
	1.5:1	3,700 (16.47)	3,700 (16.47)	3,700 (16.47)	3,700 (16.47)	3,700 (16.47)	3,700 (16.47)	3,700 (16.47)	3,700 (16.47)	4,500 (20.03)
	1:1	3,700 (16.47)	3,700 (16.47)	3,700 (16.47)	4,500 (20.03)	7,000 (31.15)	7,000 (31.15)	7,000 (31.15)	10,000 (44.50)	10,000 (44.50)
AB600	5:1 - 2:1	3,700 (16.47)	3,700 (16.47)	3,700 (16.47)	3,700 (16.47)	3,700 (16.47)	3,700 (16.47)	3,700 (16.47)	3,700 (16.47)	3,700 (16.47)
	1.5:1	3,700 (16.47)	3,700 (16.47)	3,700 (16.47)	3,700 (16.47)	3,700 (16.47)	4,500 (20.03)	4,500 (20.03)	7,000 (31.15)	7,000 (31.15)
	1:1	3,700 (16.47)	4,500 (20.03)	7,000 (31.15)	7,000 (31.15)	10,000 (44.50)	10,000 (44.50)	15,000 (66.75)	15,000 (66.75)	15,000 (66.75)
AB800	5:1 - 2:1	3,700 (16.47)	3,700 (16.47)	3,700 (16.47)	3,700 (16.47)	3,700 (16.47)	3,700 (16.47)	3,700 (16.47)	3,700 (16.47)	3,700 (16.47)
	1.5:1	3,700 (16.47)	3,700 (16.47)	3,700 (16.47)	4,500 (20.03)	4,500 (20.03)	7,000 (31.15)	7,000 (31.15)	7,000 (31.15)	10,000 (44.50)
	1:1	3,700 (16.47)	7,000 (31.15)	7,000 (31.15)	10,000 (44.50)	15,000 (66.75)	15,000 (66.75)	15,000 (66.75)	23,000 (102.35)	23,000 (102.35)
AB1000	5:1 - 2:1	3,700 (16.47)	3,700 (16.47)	3,700 (16.47)	3,700 (16.47)	3,700 (16.47)	3,700 (16.47)	3,700 (16.47)	3,700 (16.47)	3,700 (16.47)
	1.5:1	3,700 (16.47)	3,700 (16.47)	7,000 (31.15)	7,000 (31.15)	7,000 (31.15)	7,000 (31.15)	10,000 (44.50)	10,000 (44.50)	10,000 (44.50)
	1:1	7,000 (31.15)	7,000 (31.15)	10,000 (44.50)	15,000 (66.75)	15,000 (66.75)	15,000 (66.75)	23,000 (102.35)	23,000 (102.35)	23,000 (102.35)
AB1200	5:1 - 2:1	3,700 (16.47)	3,700 (16.47)	3,700 (16.47)	3,700 (16.47)	3,700 (16.47)	3,700 (16.47)	3,700 (16.47)	3,700 (16.47)	3,700 (16.47)
	1.5:1	3,700 (16.47)	3,700 (16.47)	7,000 (31.15)	7,000 (31.15)	7,000 (31.15)	10,000 (44.50)	10,000 (44.50)	15,000 (66.75)	15,000 (66.75)
	1:1	7,000 (31.15)	10,000 (44.50)	15,000 (66.75)	15,000 (66.75)	23,000 (102.35)	23,000 (102.35)	23,000 (102.35)	23,000 (102.35)	NA

Requirements for Installing and Anchoring Liners and Mats

Slopes

The prepared areas should not be more than 2.5 inches (65 mm) below the grades indicated on the Contract Drawings, and should not vary more than 1.5 inches (40 mm) in 10 feet (3 m) as measured with a straightedge. Where such areas are underwater, they should be backfilled with crushed rock or stone conforming to the grading and quality requirements of 0.75 inch (20 mm) maximum size coarse aggregate for concrete.

Note: Though fabric-formed concrete can be installed on slopes steeper than those suitable for quarry stone or precast concrete blocks or for compacted soil or soil cement construction, fabric formed concrete linings and mats are not designed to improve slope stability. Their inherent weights are selected for the purposes of hydraulic stability and are not to be considered sufficient to impart stability to slopes subject to rotational, global or sliding failure or where severe consolidation of the subgrade is anticipated.

Flank, Anchor (side), and Toe Trenches or Aprons

Flank, anchor (side), and toe trenches or aprons should be excavated along the lines, grades and dimensions shown on the Contract Drawings. Trenching equipment works well provided the upper inside edge of the trench is rounded by hand in order that the fabric formed concrete lining or mat extends over a curve rather than a corner at the slope-to-trench transition (Fig. 25).

Crown Protection

Rivers and Channels

The top elevation of a fabric-formed concrete lining or mat installation should be extended to the top of the slope or to a point above the maximum design high water elevation plus a freeboard of a minimum of 2 ft (60 cm) with an additional allowance for run up from waves or boat wakes (Fig. 26).

It is recommended that fabric-formed concrete linings and mats should be extended horizontally at the top of the slope or onto a bench for a minimum distance of 2 ft (60 cm) and then placed in an anchor trench a minimum depth of 1.5 ft (50 cm) (Fig. 26). For sandy soils, a rounded shoulder and sloped trench side is normally used (Fig. 26.1).

Shorelines, Lakes, Reservoirs and Retention Basins

The top elevation of a fabric-formed concrete lining or mat installation should be extended to the top of the slope or to a point above the maximum run up from design waves or boat wakes (Fig. 27).

It is recommended that fabric-formed concrete linings and mats should be extended horizontally at the top of the slope or onto a bench for a minimum distance of 2 ft (60 cm) and then placed in an anchor trench a minimum depth of 2 ft (60 cm) (Fig. 27).

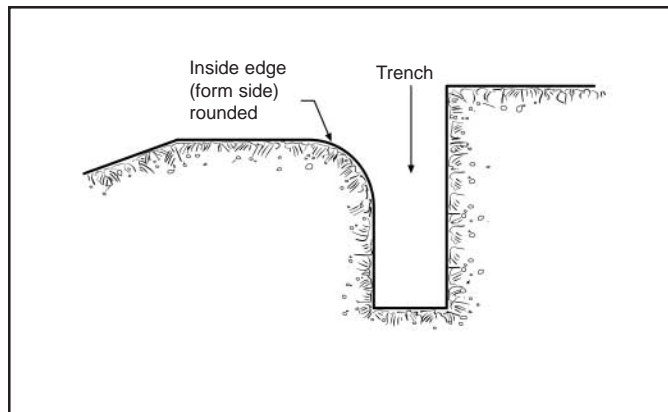

Figure 25

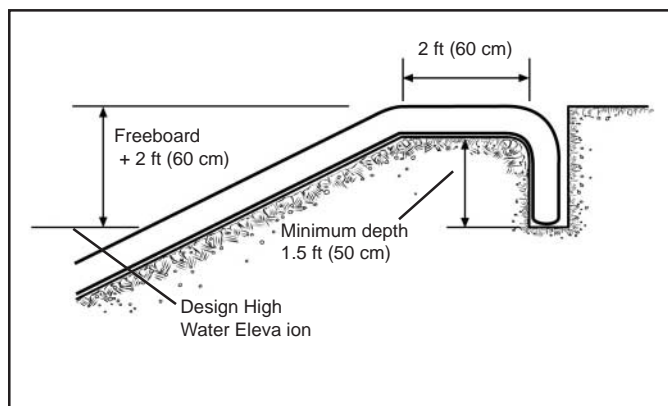

Figure 26

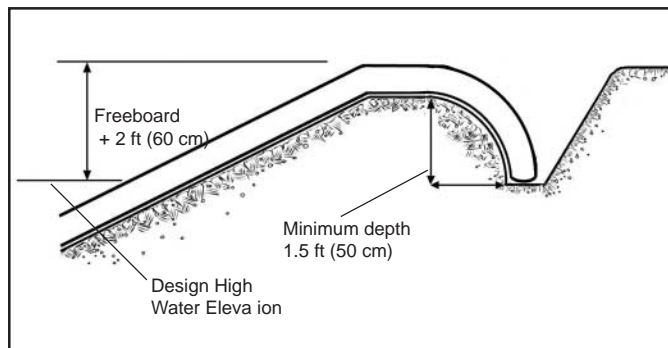

Figure 26.1

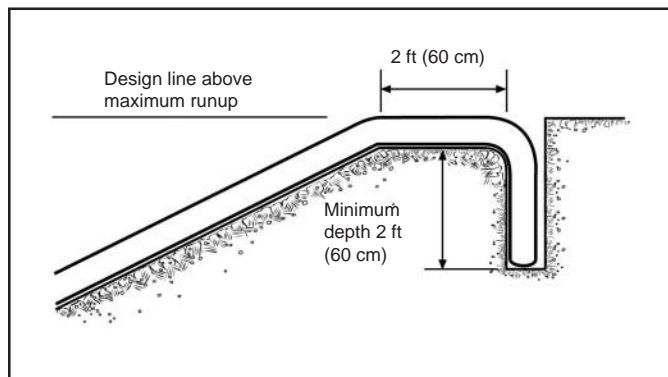

Figure 27

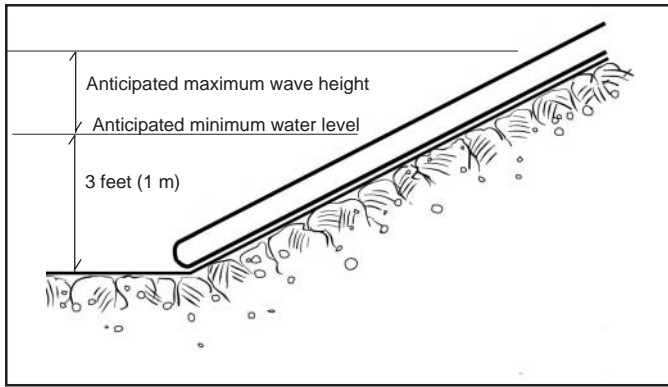

Figure 28

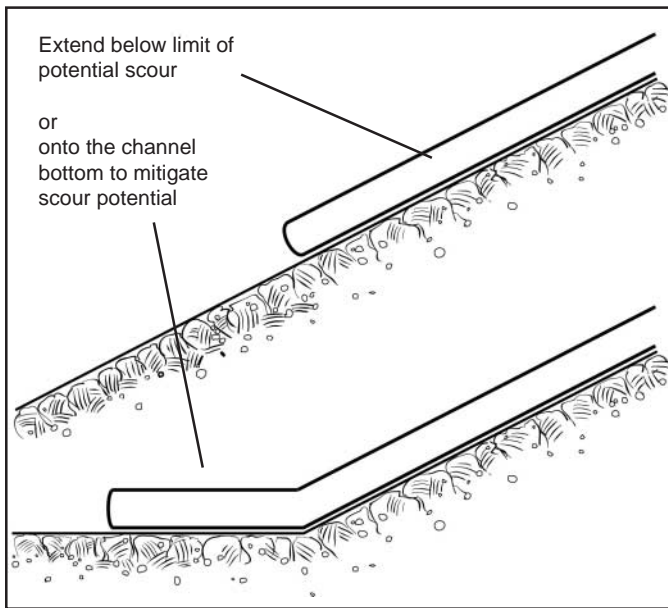

Figure 29

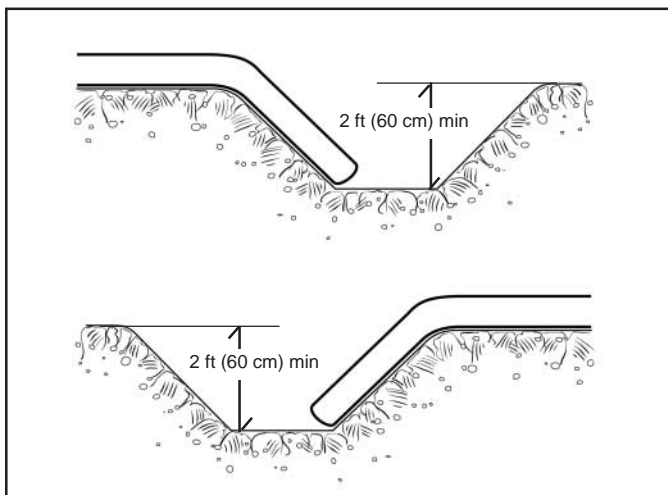

Figure 30

When constructing crown protection for either rivers and channels or shorelines, lakes, reservoirs and retention basins it is important to note that overtopping may cause erosion immediately above the protection that may eventually undermine and collapse the concrete linings, mats and armor units.

Toe Protection

The lower edges of a concrete lining or mat installation should be extended a minimum vertical distance of 3 ft (1 m) below anticipated minimum water level plus a distance equal to the anticipated maximum design wave height (Fig. 28). Additional toe protection may be required where the structure is in the vicinity of commercial shipping or where toe scour is known to be severe. The lower edge of the mat should extend to an elevation below that at which scour might occur or extend onto the channel bottom to mitigate scour (Fig. 29). This procedure will reduce the possibility of washout of soil from beneath the lining or mat.

Flank Trenches

The terminal ends of a fabric formed concrete lining or mat installation should be placed in a flank trench that is excavated at an angle of about 45° from the normal angle of the subgrade.

Rivers and Channels

Though the downstream flank of a concrete lining or mat installation is the most vulnerable point to the tractive forces of flowing water, it is recommended that both the downstream and upstream flanks be protected with flank trenches with a minimum depth of 2 ft (60 cm) (Fig. 30).

Shorelines, Lakes, Reservoirs and Retention Basins

Both flanks of a concrete lining or mat installation are equally vulnerable to the erosive forces of wave action and currents. They should both be protected with flank trenches with a minimum depth of 2 ft (60 cm) (Fig. 30).

Note:

The requirements listed on these pages for the anchoring and protection of linings and mats are given for guideline purposes only. For an actual installation, these parameters must be established by a qualified Hydraulics Engineer, based on his calculations of the requirements for a specific project. Geostar Corporation assumes no responsibility for the performance of an installation whose design has not been reviewed by a qualified engineer.

Installation of HYDROTEX Linings and Mats

Equipment and Tools

Because of the simple installation procedure for the HYDROTEX linings and mats, a nominal amount of tools and equipment is required. We suggest that the contractor have on hand the following:

Tools:

- Surveyor's level and rod
- Shovels
- Rakes
- Hammer
- Stakes
- String line
- Rubber boots and gloves
- Pail
- Trowels
- Safety glass or goggles
- Scissors
- Crimping tool (for Articulating Block only)

Equipment:

- Small line concrete pump
- Concrete pump hose - 2 inch (50 mm) diameter
- Injection pipe - 2 inch (50 mm) diameter (Fig. 31)
- Hand-held sewing machine (electric or air powered) with speed control
- Extension cord (if electrical equipment is used)
- Electric generator with ground fault circuit breaker
- Air compressor (if air powered sewing machine is used)
- Narrow trench digging equipment (optional)
- Small, walk-behind flat or vibratory compactor for soil compaction
- Post digger or auger (if steel anchor rods are specified)

Lists of equipment manufacturers are provided in the appendices. However, Geostar Corporation makes no warranty nor guarantees the performance of equipment provided by another manufacturer.

Sequence of Fabric Form Installation

Once the area to be protected has been excavated, graded and compacted to the lines and grades specified in the Contract Drawings and Specifications an installation crew, filter fabric, if required, fabric forms and the tools and equipment listed above should be mobilized to the job site. *Freshly excavated and graded slopes are highly subject to erosion and should be protected from water runoff, flowing water and waves.*

Depending on the location of the area, dimensions, and the rate of subgrade preparation, installation

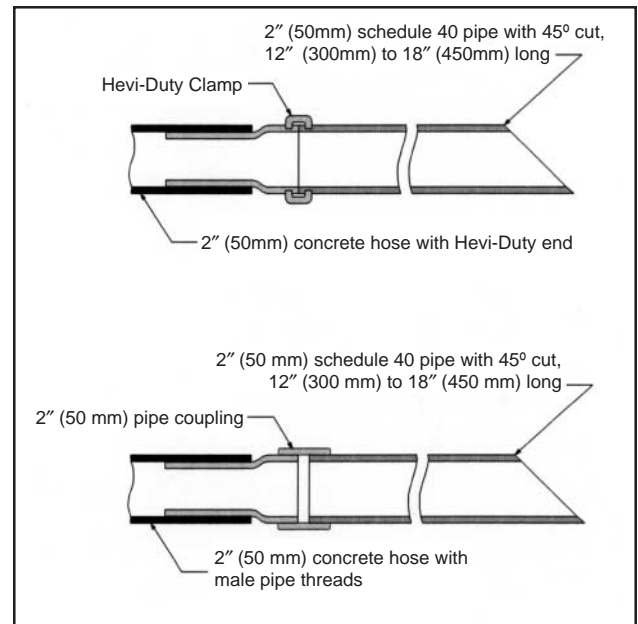

Figure 31

Equipment Traffic:

Equipment that could crack, cause abrasion, or otherwise damage the concrete should not be allowed on the installed fabric-formed linings and mats.

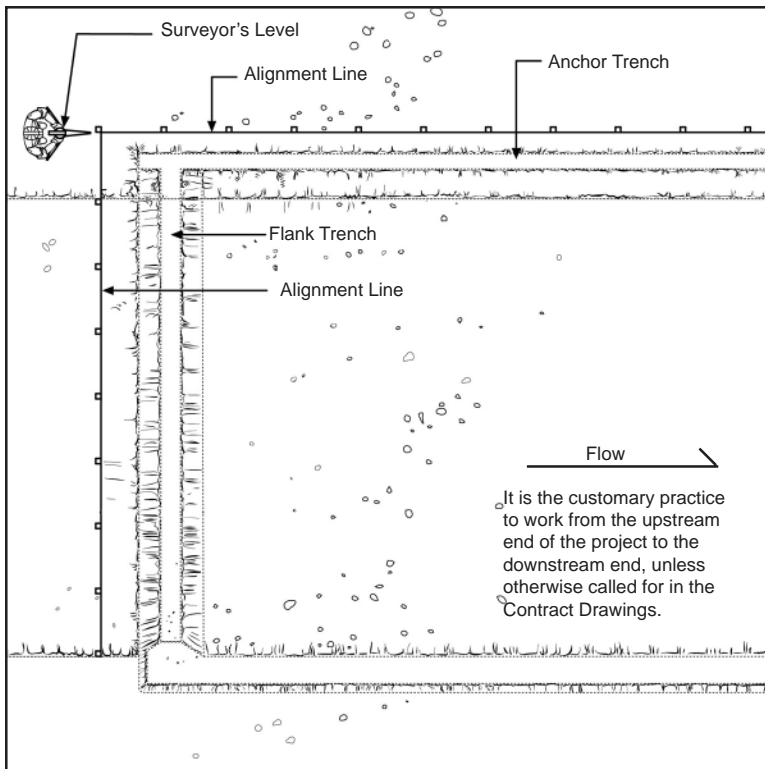

Figure 32

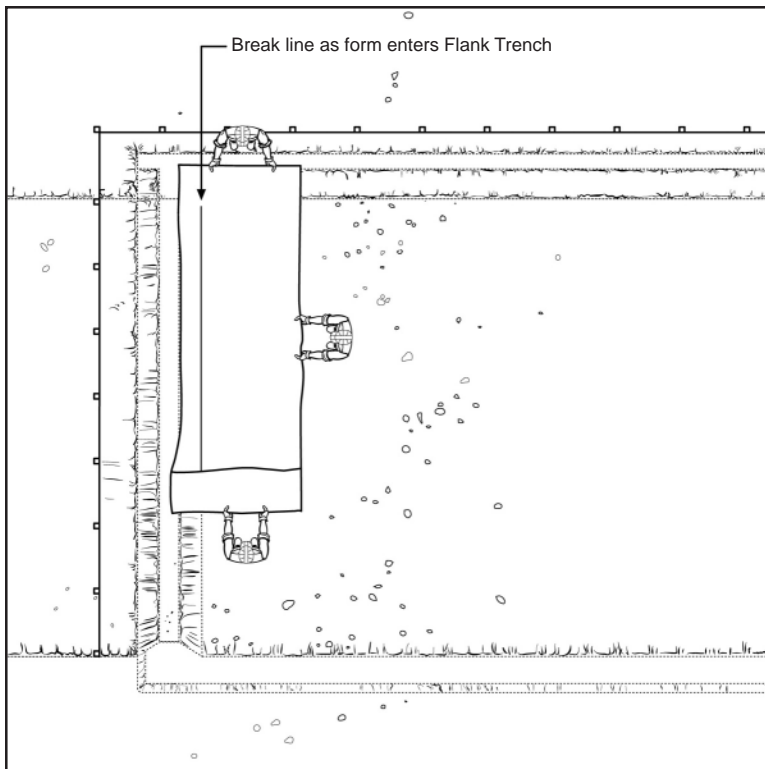

Figure 33

rates of as much as 15 yd³ (11.5 m³) of fine aggregate concrete per hour can be achieved by a crew of 3 or 4 laborers, a concrete pump operator and a supervisor.

Establish the starting point

The first step in the installation of fabric formed concrete linings and mats is to establish a starting point. If a working point and direction of placement are shown on the Contract Drawings this should be the starting point. If this is not the case, it is the customary practice to work from the upstream end of the project to the downstream end. In this manner the flow of the water will tend to spread the fabric forms out ahead of the finished work and the finished concrete lining or mat are protected from undercutting (Fig. 32). *Fabric form panel layout drawings, available from Geostar Corporation, will recommend starting points and directions of placement for the project.*

Establish the alignment lines

Once a starting point has been established a surveyor's level should be used to determine the longitudinal and slope alignment lines of the fabric formed concrete linings or mats (Fig. 32). String lines should then be placed along the respective alignment lines and staked. Generally, the alignment lines are offset, by a measured distance, to the opposite side of any trench or a minimum of 5 feet (1.5 m) in order not to interfere with the work area (Fig. 32). *The method of establishing reference points and lines should be left to the discretion of the contractor.*

Placement of the filter fabric, if required

Under certain soil conditions or if called for in the Contract Drawings and Specifications, it will be necessary to place filter fabric and/or a granular sublayer under the fabric forms to guarantee the functioning of the filter points, filter bands, permeable interwoven perimeters, or weep tubes. Filter fabric should be selected and placed in accordance with the Contract Drawings and Specifications or in the absence of such directions in accordance with the manufacturer's guidelines. If called for in the Contract Drawings and Specifications, steel anchor rods should be installed prior to placement of a geotextile filter fabric. The anchor rods should be forced through the filter fabric. *Filter fabrics and their installation are discussed, in brief, earlier in this manual.*

Placement of the first fabric form panel

The prefabricated panels are accordion folded and then rolled and marked with the appropriate panel numbers at the factory for easy identification, location and installation.

The first fabric form panel should be carefully placed at the designated starting point and rolled out into position (Fig. 33).

The panel should be extended into position by pulling the leading side of the panel in the direction of the concrete lining or mat placement (Fig. 34). Special care should be taken to assure that the sides and the ends of the panel are exactly parallel to their respective alignment lines.

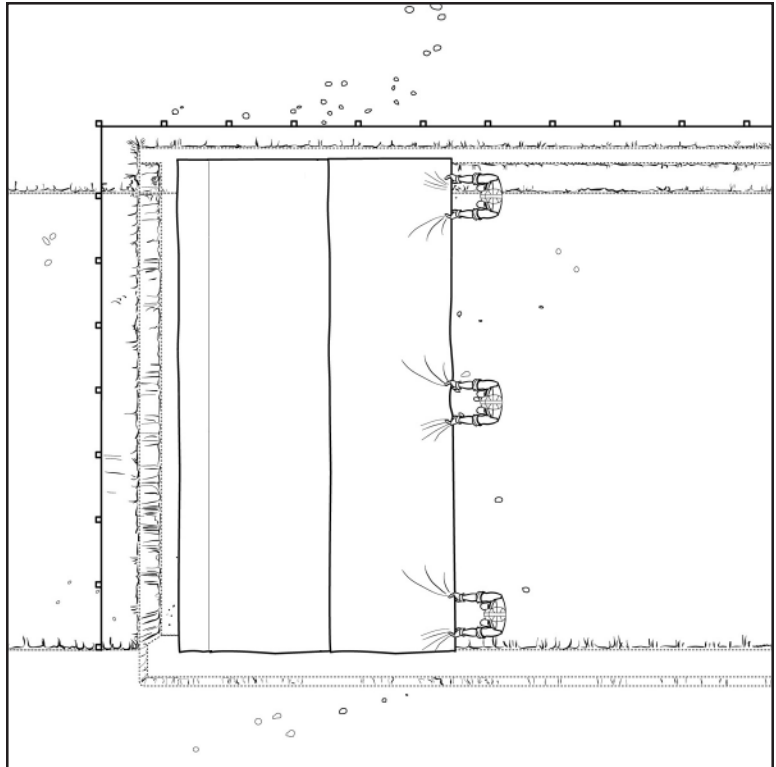

Figure 34

Fabric form panels should be placed loosely, but without folds, to allow for proper filling with fine aggregate concrete. The extra fabric form provided for form contraction should be gathered into temporary tucks at the top of the slope and at each seam (Figs. 35 and 36). Panels that are stretched or taut will not permit the required fabric contraction, therefore the fabric forms will not fill to their required thickness. For example, an 11 mill-width-wide panel of Filter Point fabric form will be 66 feet (20 m) wide. When filled with fine aggregate concrete the width will contract to a finished width of 60 feet (18 m). See Table 7 for the contraction factors of the various form styles. The fabric form in this example should therefore be placed with the seams (which join mill widths) 5.5 feet (1.6 m) apart. If called for in the Contract Drawings and Specifications, steel anchor rods should be forced through both layers of the fabric form.

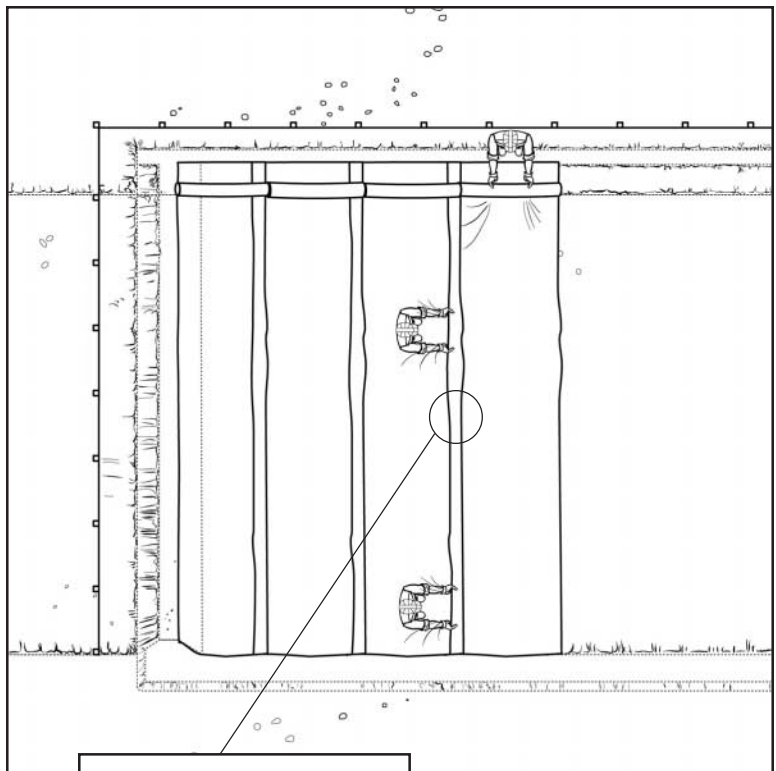

Figure 35

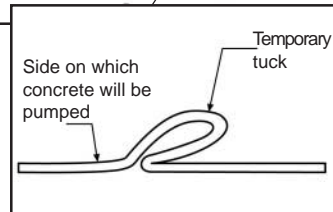

Figure 36 - Detail View of Tuck

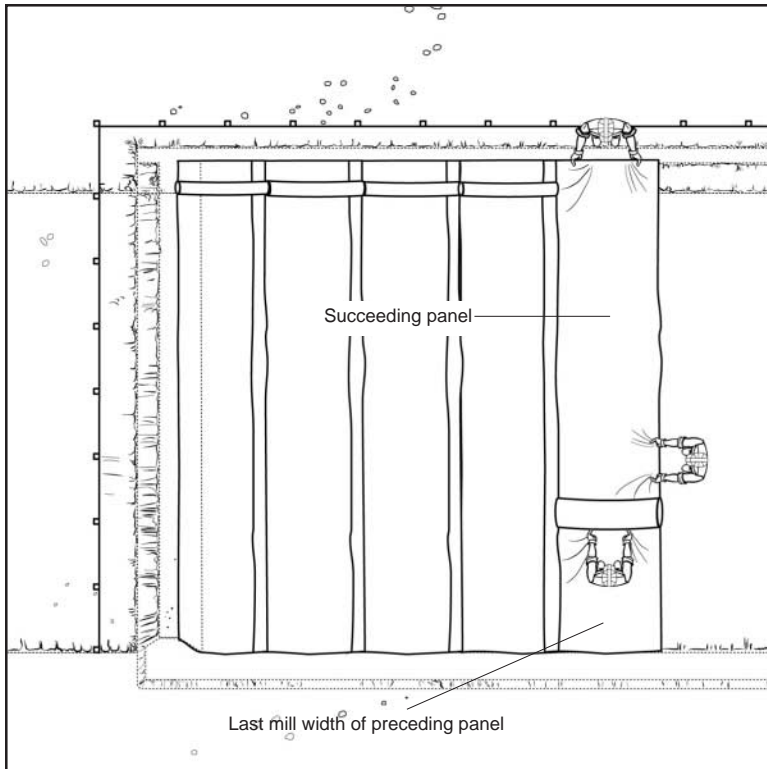

Figure 37

Placement of the second and remaining fabric form panels (sewn seams)

The succeeding panel should be placed atop the last mill width of the preceding panel so that their adjoining sides are abutting, as shown in Figure 37. The succeeding panel is then joined to the preceding panel by sewing. The panels should be joined together, edge-to-edge, by field sewing the top edge to top edge and the bottom edge to bottom edge (Fig. 38 and 39).

Placement of the second and remaining fabric form panels (zippered seams)

The succeeding panel should be placed adjacent to the last mill width of the preceding panel so that their adjoining sides are abutting. The succeeding panel is then joined to the preceding panel by zipping the panels together (Fig. 40).

Note: When installing Articulating Block (AB) Fabric Forms, optional transverse cables are spliced together prior to joining the second layers of fabric.

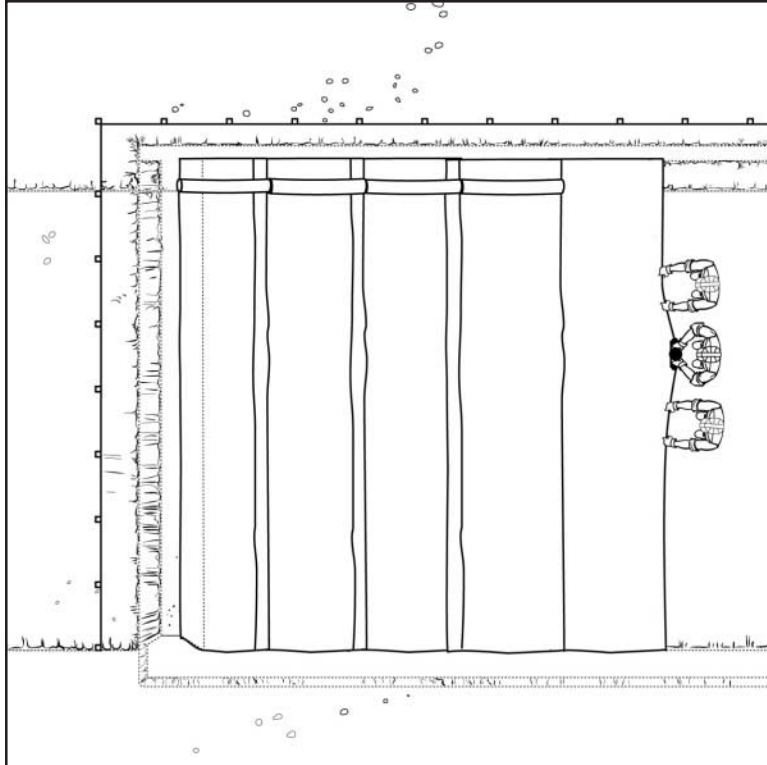
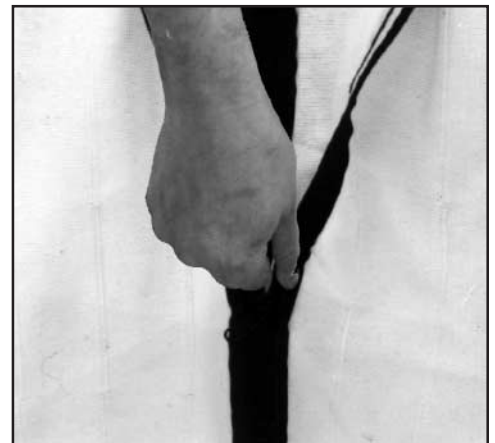

Figure 38



Figure 39 - Sewing Fabric Panels

Figure 40 - Zippering Fabric Panels



- **The second panel** should then be extended in the direction of alignment and all seams should be downward facing (Fig. 41). After the second panel has been positioned, the alignment of the panels should be checked. The alignment of the fabric should be checked periodically since small errors in alignment can progress in severity.
- **The remaining panels** should be placed side-by-side in the same manner. If care has been taken in placing the panels, little if any further adjustment of panels should be required. However, panel alignment is important in providing a uniform and attractive appearance in the finished installation.

Fabric form placement should proceed concrete filling by no more than the distance that can be completed in one day.

If the panels are to be placed underwater or if the aesthetic appearance is not of importance, the time involved in inverting the panels as described above may not be justified. Adjacent panels may be joined by abutting the panels and sewing the bottom and then the top seam. Except for the small tab of fabric that will protrude above the surface of the concrete lining or mat, seaming the fabric in this manner is functional and will not adversely effect the performance of the installation.

Sewn seams should be made using portable, hand-held, sewing machines and nylon or polyester sewing thread. Generally, a prayer seam with a U.S. Federal Standard Type 101 stitch is the most suitable. It is strongly recommended that each seam be made with two parallel passes of the sewing machine to assure a tight seam equivalent to those seams sewn in the factory. *Whenever possible, the second pass of the sewing machine should run in the direction opposite to but parallel to the first pass.*

Three (3) laborers are generally required for the sewing or zippering of seams; one to operate the sewing machine or zipper pull, one to align the fabric form and one to inspect the seam.

Sewing machines suitable for field use are listed in Appendix 2. There are both electric and air powered sewing machines listed. The electric sewing machines should be provided with a speed control rheostat. The air powered sewing machines have a built-in speed control. The air powered machines are more expensive; however, they are safer when working in a wet environment.

All seams sewn in the field shall be not less than 90 lbf/in (15.7 kN/m) when tested in accordance with ASTM D 4884. Colored thread is preferable for seams, since defects such as broken threads, seams too close to the edge of the fabric or a machine that is skipping are immediately apparent.

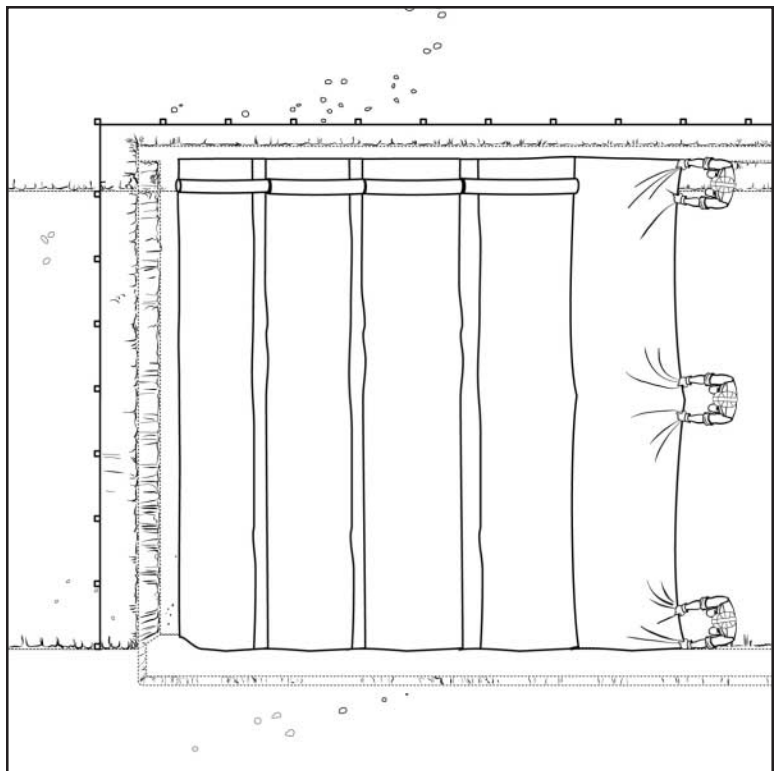

Figure 41

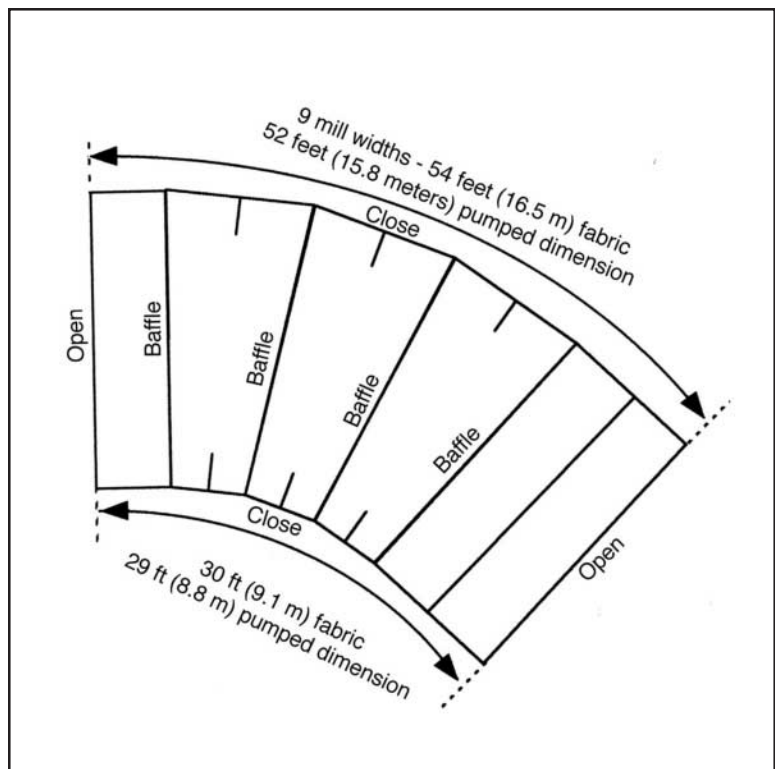

Figure 42

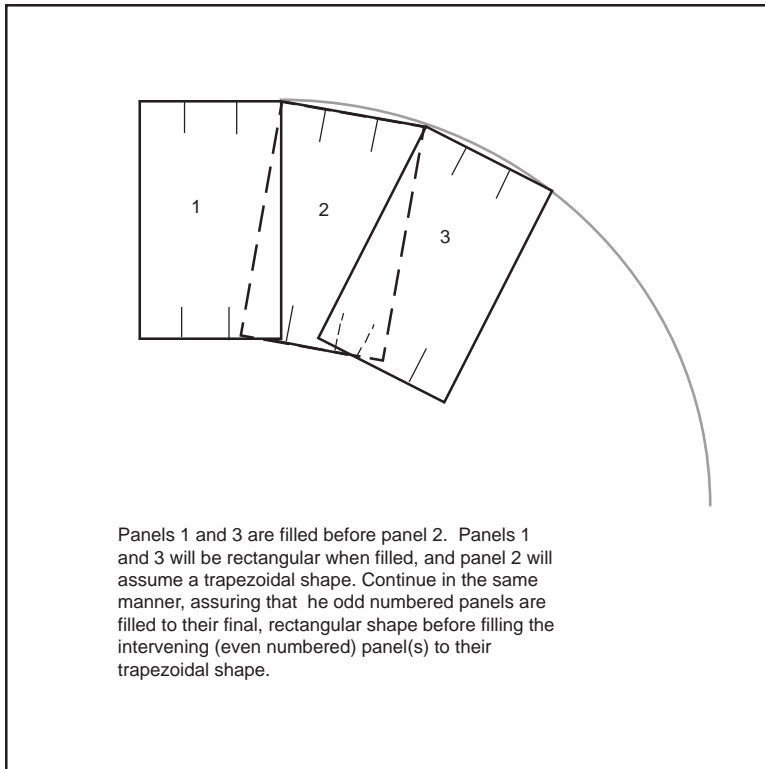

Figure 43

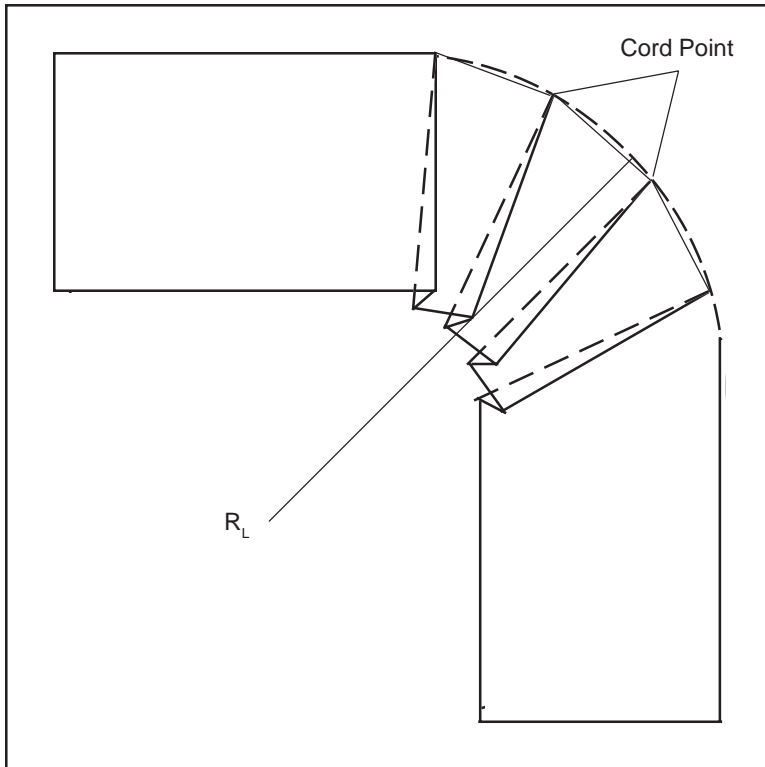

Figure 44

Placement of fabric form panels around curves and turns

Curves or turns may be accomplished by panels with one or more angled mill widths. Panels with angled mill widths should be carefully prefabricated or field assembled by cutting and sewing the mill widths of the fabric form(s) to obtain true angles and edges (Fig. 42).

Curves and turns in the project can also be accomplished by positioning the sides of alternate panels perpendicular to the concrete lining or mat's longitudinal alignment line. The alternate panels should then be pumped to form standard rectangular shaped sections. The intermediate panels should then be pumped. These intermediate panels will form sections with a slightly trapezoidal shape to complete the curve or turn (Fig. 43).

A third method to accomplish curves and turns in the project is to place baffles between each mill width. Then set predetermined seams at one end of the mill width at their normal spacing at cord points along the larger radius of the curve or turn and then set the seams at the other end of the panel at a measured spacing at cord points along the smaller radius of the curve or turn. The excess width of fabric form, between seams, is carefully accumulated into pleats that taper the mill width down toward the smaller radius (Fig. 44).

Placement of fabric form panels into trenches

After the fabric form panels have been positioned, the designated sides of the panels should be folded into the anchor trench, flank trenches and toe trench.

Underwater placement of fabric forms may require the use of divers. The divers can prepare the finished grading, inspect the area to be protected, and position and secure the filter fabric and fabric forms. The securing of the fabric may require sand bags or weights, or lines tied from shore to hold the fabric in position.

A small quantity of bulk (uncut and unassembled) fabric form should be ordered for each project. This fabric can be used for special field tailoring around drains, headwalls and field changes requiring extensions to pre-assembled panels. At least half a roll, about 900 ff² (84 m²), of bulk fabric is recommended.

Sequence of Fine Aggregate Concrete Pumping

Ordering fine aggregate concrete

Fine aggregate concrete is generally delivered to the job site in ready-mix trucks. The order for concrete should be placed a least one day prior to its scheduled delivery to the job site. The concrete supplier should be instructed to fill the water tank of each truck with mix water. *It is common that the first few loads delivered to the job site will not be fluid enough for pumping and will require the addition of mix water.* In order to avoid presetting of the fine aggregate concrete it is recommended that the concrete be delivered in loads of no more than 8 yd³ (6 m³). At a minimum, the first load of each day should be checked with a standard flow cone for consistency, in accordance with ASTM D 6449.

Securing the fabric form panels

Beginning at the designated starting point the installation crew should check and adjust the fabric form panel's seams to assure that they are perpendicular to the longitudinal alignment line. After the panel has been properly adjusted fine aggregate concrete is either pumped into the portion of the fabric form panel that has been placed into the anchor trench (Fig. 45) or the form is secured to structures such as a retaining walls, abutments or curbs. *Insert a pipe or reinforcement bar through a hem sewn along the top edge of the fabric form and secure the pipe or bar to an anchor (Fig. 46).* Securing the panel should help control the position of the panel and should prevent the freshly filled fabric form from sliding down the slope. *It must be emphasized that care should be exercised in the alignment and securing of the first fabric form panel. This will ensure the aesthetics of the concrete lining or mat and also hasten the installation of subsequent panels. Fabric should be placed loosely at the connection or anchor to allow for contraction in both directions during filling.*

Inserting the fine aggregate concrete injection pipe

Fine aggregate concrete should be pumped into the fabric form panel by inserting the injection pipe through a small slit cut in the upper layer of fabric (Fig. 47). *Care must be taken not to cut through the bottom layer of the fabric form.* A tight seal should be made by wrapping a piece of nonwoven fabric

Safety:

All on site personnel should wear safety hats, glasses or goggles, rubber gloves and boots at all times. Electric equipment should be provided with ground fault circuit interrupters and circuit breakers. Concrete pumps and hoses should be handled with care and operated in strict accordance with their manufacturer's safety instructions.

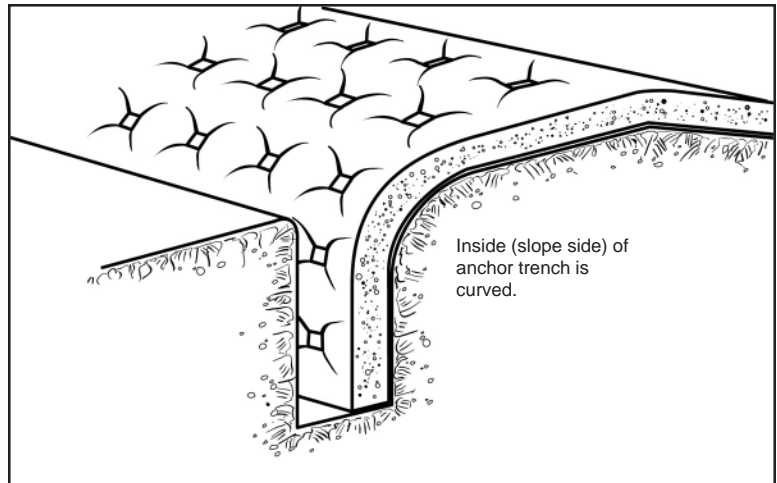

Figure 45

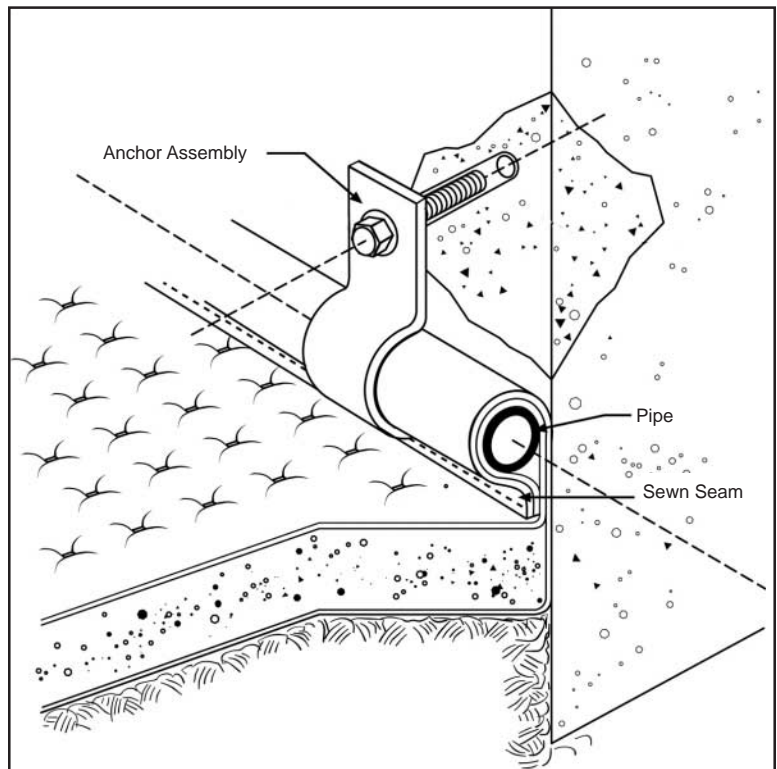

Figure 46



Figure 47

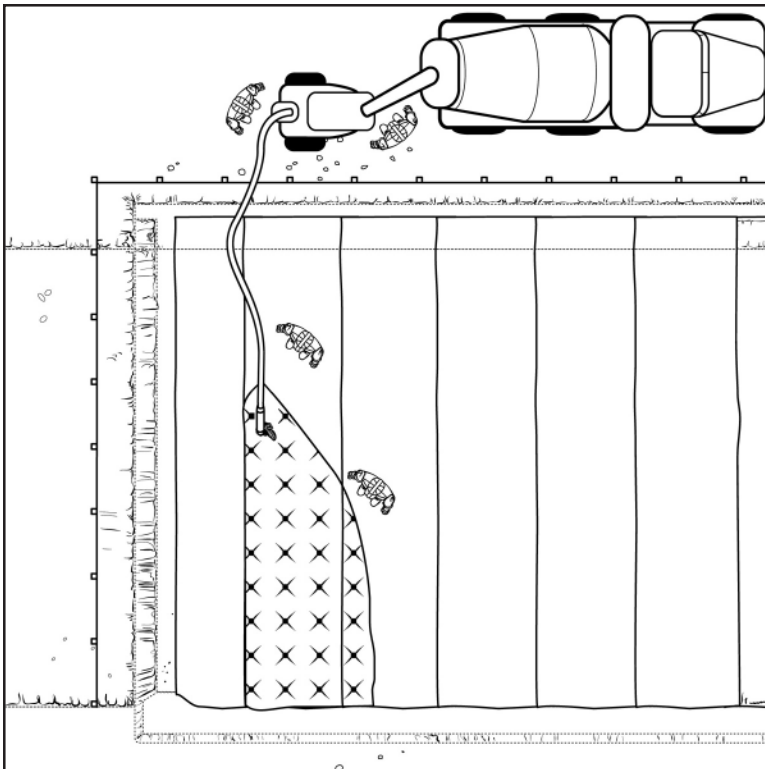

Figure 48

around the pipe. When the pipe is withdrawn, the nonwoven fabric should be stuffed into the hole to provide a temporary closure. When the concrete has stiffened and is no longer fluid, the fabric should be removed and the concrete surface should be smoothed by hand.

Filling the first fabric form panel with fine aggregate concrete

The first section of the first panel has generally been placed into a flank trench. In order to eliminate the sliding of the panel into the trench during fine aggregate concrete filling, the general practice is to first fill the second section of the first panel, to anchor the fabric. Starting at the second section of the first panel, the injection pipe should be inserted at a point near the inside of the first baffle and a measured distance along the length of the panel. (See Table 10.0.)

The second panel section should be filled by pumping fine aggregate concrete between the panel's top and bottom layers of fabric. The flow of fine aggregate concrete should be directed toward the toe or lower end of the panel (Fig. 48).

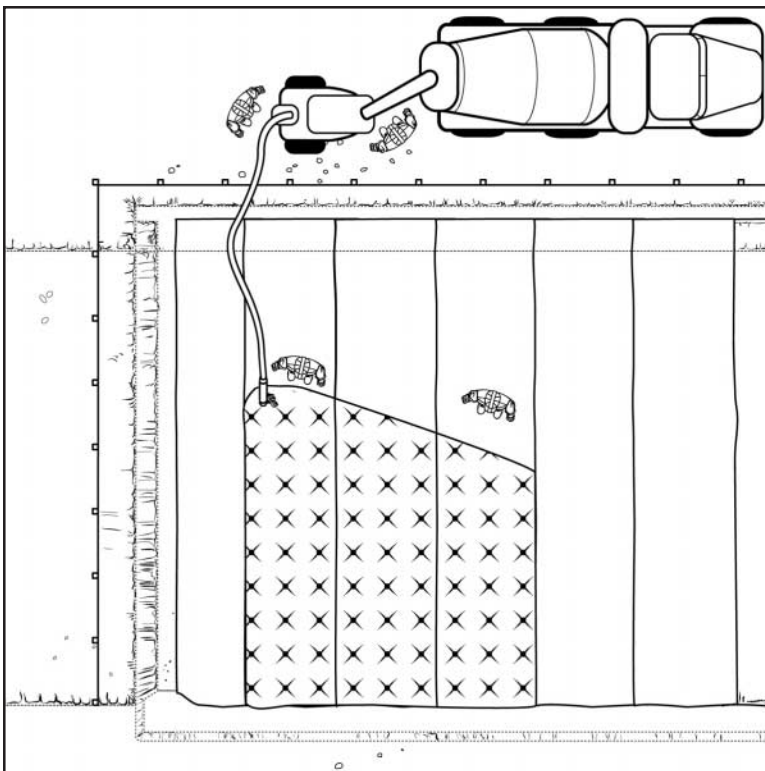

Figure 49

The fine aggregate concrete should fill the toe or lower end of the panel, proceeding gradually up and laterally across to the second baffle of the panel and to an elevation not less than 2 feet (500 mm) above the point of concrete injection (Fig. 49). *Pressure from the concrete fill helps to seal off the point of concrete injection.* If the point of concrete injection is not at the crown of the slope, the injection pipe is reinserted further up the panel and the flow of concrete is once again directed down the panel. *Experienced installation crews are able to pump to an elevation above the point at which the concrete injects.*

Wetting down of fabric forms:

As fine aggregate concrete is pumped into the fabric forms, excess mixing water will be expelled through the fabric and the concrete will stiffen rapidly. When pumping fabric forms with relatively thin cross-sectional thickness, down a long slope, across a wide section or on a relatively flat surface above water, it may be desirable to wet down the fabric prior to pumping concrete.

Table 10.0 - Maximum Distance Between Injection Points, Measured Along the Length of the Panel (ft/m)

Slope		4:1	3:1	2:1	1:1
Product	Size	L	L	L	L
Filter Point	220	35 (10.7)	46 (14)	65 (19.8)	75 (22.9)
	400	64 (19.5)	75 (22.9)	65 (19.8)	41 (12.5)
	600	69 (21.0)	53 (16.2)	37 (11.3)	24 (7.3)
	800	39 (11.9)	30 (9.1)	21 (6.4)	13 (4.0)
	1000	32 (9.8)	24 (7.3)	17 (5.2)	11 (3.4)
	1200	20 (6.1)	15 (4.6)	11 (3.4)	7 (2.1)
Filter Band	400	64 (19.5)	75 (22.9)	70 (21.3)	63 (19.2)
	800	55 (16.8)	42 (12.8)	30 (9.1)	19 (5.8)
	1200	26 (7.9)	20 (6.1)	14 (4.3)	9 (2.7)
Uniform Section	300	48 (14.6)	63 (19.2)	70 (21.3)	75 (22.9)
	400	64 (19.5)	70 (21.3)	75 (22.9)	64 (19.5)
	600	75 (22.9)	64 (19.5)	45 (13.7)	28 (8.5)
	800	33 (10.1)	25 (7.6)	18 (5.5)	11 (3.4)
	1000	22 (6.7)	17 (5.2)	12 (3.7)	10 (3.0)
Enviromat EL	250	40 (12.2)	52 (15.9)	70 (21.3)	75 (22.9)
	400	64 (19.5)	75 (22.9)	60 (18.3)	38 (11.6)
Enviromat EB	300	48 (14.6)	63 (19.2)	75 (22.9)	67 (20.4)
	500	80 (24.4)	67 (20.4)	48 (14.6)	30 (9.1)
Articulating Block	400	60 (18.3)	65 (19.8)	70 (21.3)	75 (22.9)
	600	65 (19.8)	70 (21.3)	75 (22.9)	56 (17.1)
	800	75 (22.9)	70 (21.3)	61 (18.6)	38 (11.6)
	1000	70 (21.3)	54 (16.5)	38 (11.6)	24 (7.3)
	1200	53 (16.2)	40 (12.2)	29 (8.8)	18 (5.5)

Using Tables 10.0 and 10.1 -

First use Table 10.0 to determine the maximum length along the panel between injection points, based upon the slope angle and the product being used. Table 10.1 will then allow you to determine the maximum number of panel widths. Select the length to be pumped along the bottom axis and note where that intersects with the curve for each product thickness. Then read the maximum number of mill widths along the vertical axis. Round to the next highest mill width.

Over pressuring of fabric forms:

Care must be taken, when pumping fabric forms to assure that the fabric is not over pressurized. Over pressurization may cause bursting of filter points, bands or interwoven perimeters or may cause rupturing of interwoven drop cords. The style of the fabric form and field conditions will often determine the rate of vertical rise of the concrete that may be realized in pumping. Table 10.0 provides typical guidelines for pumping fabric forms. For the ease of measurement in the field, the vertical rise in concrete has been converted to slope length.

Table 10.1 - Maximum Distance between Injection Points, measured along the width of the panel (in mill widths)

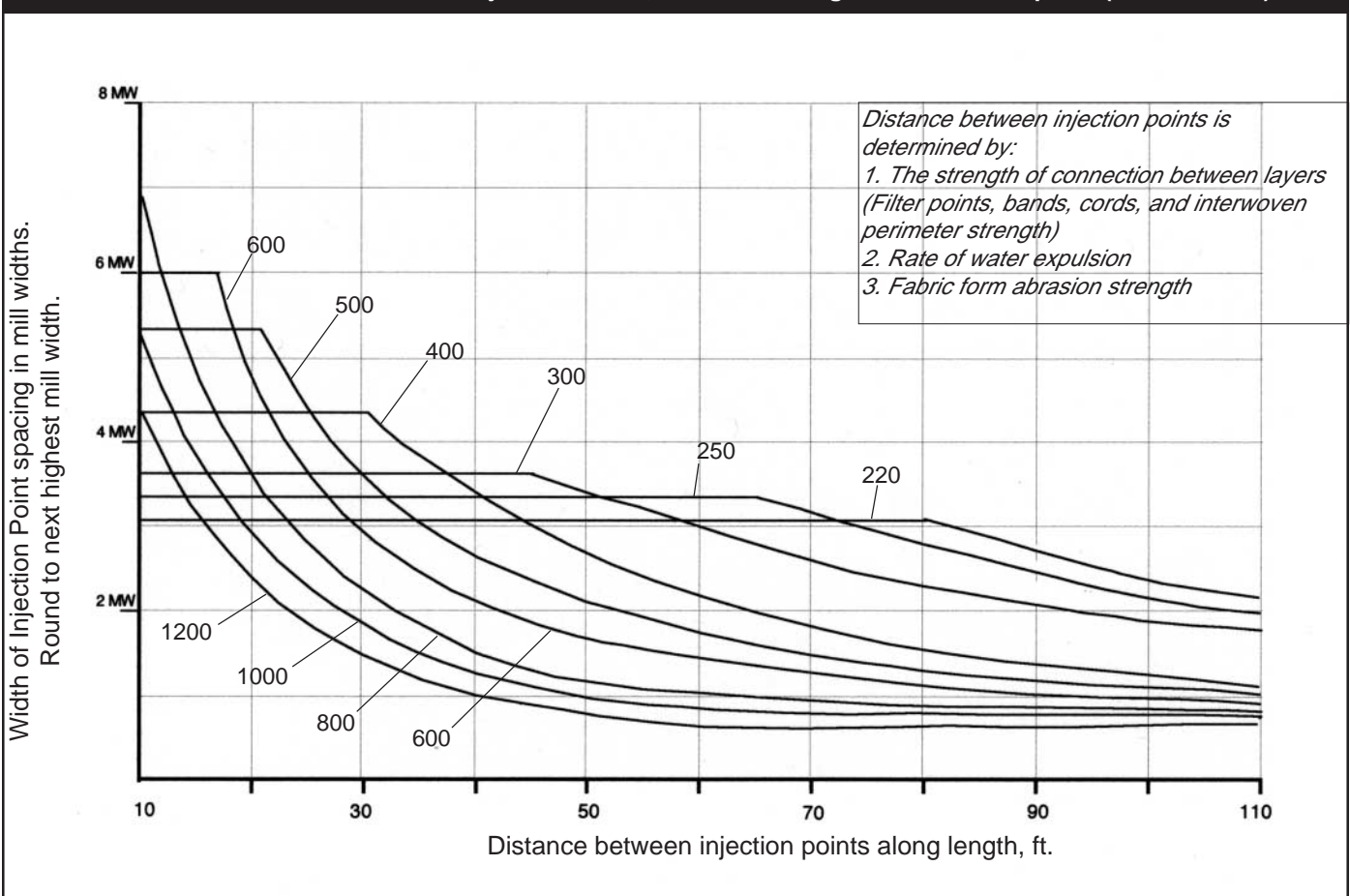

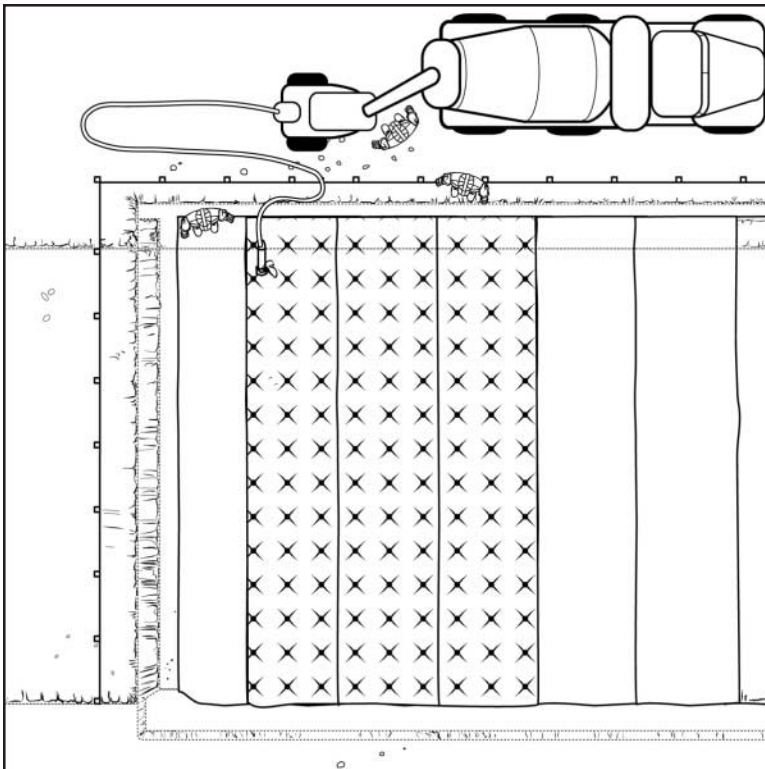

Figure 50

This procedure is repeated until the second section of the first panel has been filled to its specified thickness from baffle to baffle and from the toe or lower end to the anchor trench or top end (Fig. 50).

When installing fabric formed linings or mats on steep slopes or when the installation crew is inexperienced, it is recommended that they first fill the fabric form that has been placed in the anchor trench then proceed to directing the flow of fine aggregate concrete to the toe or lower end of the panel.

As the fabric form panel is being pumped with fine aggregate concrete the panel will contract causing a stretching and tightening of the form. In order to prevent the tightening of the fabric form and the resulting constriction of fine aggregate concrete flow, the installation crew should slowly release the temporary tucks previously placed in the fabric form at the top of the panel. *The temporarily tucks may be accumulated at the top of the panel and held in place by standing on the fabric form. As tension develops the fabric tucks are slowly released.*

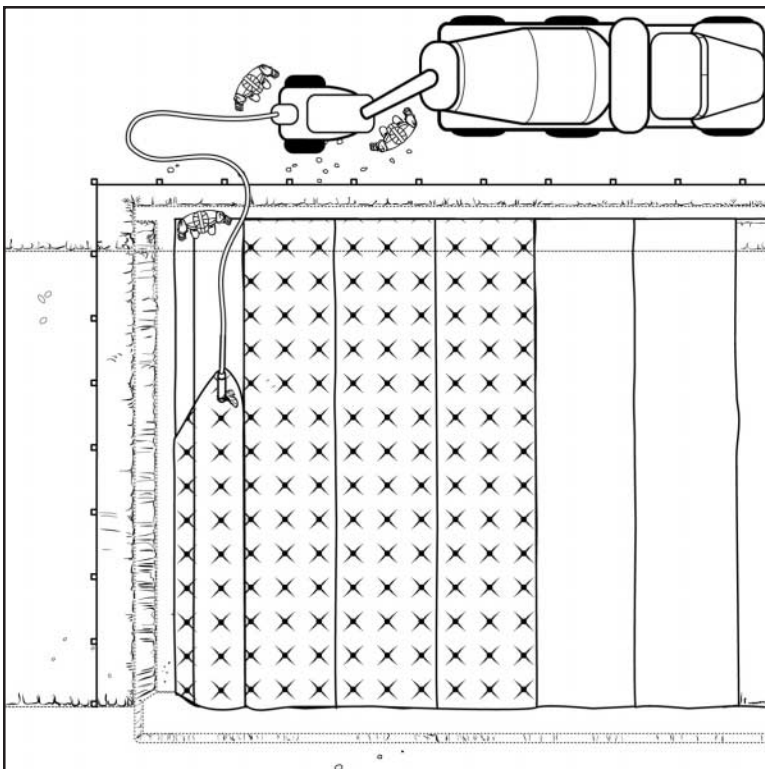

Figure 51

The injection pipe should then be moved to the other side of the baffle and inserted at a point near the baffle and a measured distance along the length of the panel (Fig. 51). Once again the previous pumping procedure should be repeated until this section of the panel has been filled to its specified thickness from baffle to baffle and from its toe or lower end to its anchor trench or top end.

Filling remaining fabric form panels with fine aggregate concrete
If care has been taken in positioning the panels and in concrete filling the first panel, little if any adjustment of subsequent panels should be required. However, panel alignment should be checked periodically since small errors in alignment can progress in severity. Periodically check the location of the panels with an instrument to assure that proper alignment is being maintained.

Special Considerations

Lap Joints

If the conventional joining of panels, by field sewing of adjacent panels, is impractical or if site conditions or project design preclude a continuous lining or mat a lap joint may be employed. Adjacent panels may be overlapped either transverse to or longitudinal to the installation. In all cases the lap must be shingled to correspond with the direction of flow.

A lap joint may be desirable along the centerline of a wide channel or a channel with changes in bottom width or slope length. It may allow the contractor the flexibility to use a standard panel size to conform to the variable design cross sections.

A lap joint may be constructed by overlapping adjacent fabric form panels by a minimum of 3 feet (1 m). **Butt joints are not permitted.** The proper method for constructing a lap joint is the following pumping sequence (Fig. 52):

- Fill the next to the last mill width of the upstream form, leaving the last section of the upstream and preceding panel unpumped.
- Excavate a terminal trench as described in Figure 52 or in the Contract Drawings.
- Position the side of the succeeding panel approximately 3 feet (1 m) from the last pumped mill width of the preceding panel.
- Pump fine aggregate concrete into the first mill width of the succeeding panel.
- Backfill the terminal trench so that the last mill width of the preceding panel can be laid to form an even transition to the succeeding panel.
- Extend the last mill width of the preceding panel over the indented portion of the first mill width of the succeeding panel and fill this section.

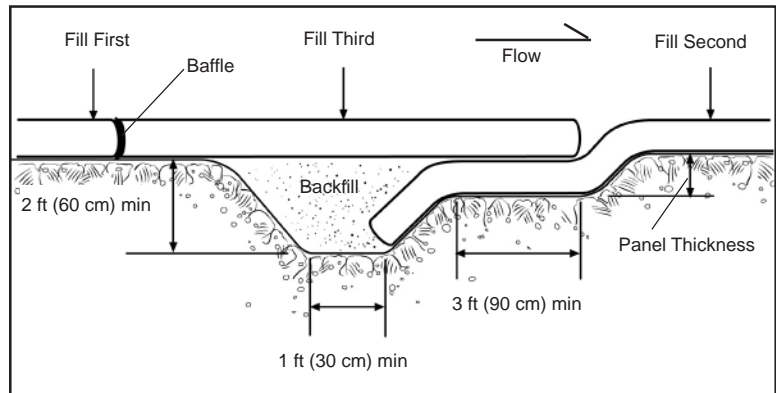

Figure 52

Pipes, piles, culverts, trees and other appurtenances

Fabric forms should be tailored in the field to fit around pipes, piles, culverts, trees and other appurtenances. An opening should be cut in the fabric form that is slightly smaller than the object and the perimeter of the opening is sewn closed. When the fabric form panel is placed the tailored opening is either slid over or wrapped around the object. As fine aggregate concrete is pumped into the section of the panel with the tailored opening it will form snugly around the object (Fig. 53).

An alternate method of construction is to first fill the fabric forms that have been placed in close proximity to the object and then to place a separate collar, snugly around the object, overlapping the primary concrete lining or mat by a minimum of 2 ft (60 cm) (Fig. 54).

Backfilling and compaction of trenches

The backfilling and compaction of anchor, flank and toe trenches and other open excavations should proceed in not less than one hour behind the concrete filling of the fabric formed linings or mats. Anchor and flank trenches should be backfilled and compacted to the top of the concrete linings or mats. Toe trenches should be backfilled as shown on the Construction Drawings. *The trenches of completed sections of concrete linings or mats should be backfilled and compacted by the end of the work day.*

Foot traffic

Foot traffic on the freshly pumped fine aggregate concrete lining or mat should be avoided for a period of not less than one hour after concrete injection or until the concrete is resistant to indentation. Should traffic be unavoidable, the contractor should place board walks along the finished filled concrete areas. This will reduce the amount of objectionable indentation. *Footprints will leave permanent impressions in the installed fabric-formed concrete linings or mats.*

Cleanup

Any fine aggregate concrete that may spill on top of the fabric formed concrete lining or mat should be picked up by hand or trowel and the surface



Figure 53

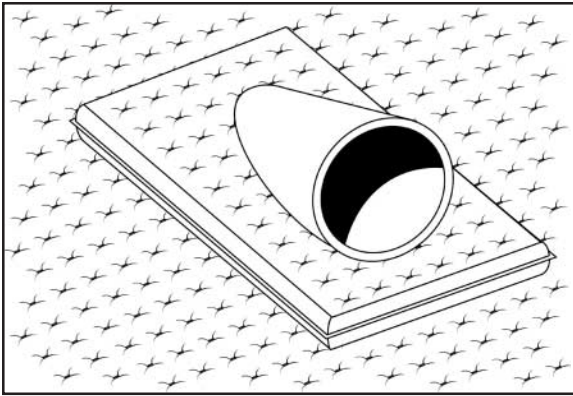

Figure 54

smoothed by cloth or broom. Such unnecessary spillage of concrete will cause an unsightly appearance and may clog the concrete lining or mat's drainage areas such as filter points, filter bands or the permeable interwoven perimeter areas of the fabric forms. *The installation crew should be instructed to carefully "kink" the concrete pump hose when it is moved from one injection point to another or to place the end of the concrete injection pipe in a pail when moving the concrete pump hose.*

The freshly pumped fabric formed concrete linings and mats should never be washed (sprayed) under pressure with water in an effort to clean or remove spills from its surface. A wet cloth should be used for clean up and spill removal.

The cement film that bleeds through the top layer of the fabric forms provides a bond between the fabric form and the concrete fill and a degree of protection against ultraviolet degradation of the fabric. Should this film be removed by washing the uncured concrete linings or mats, cement may be also washed out from beneath the top layer of fabric. The result would be a loss of concrete-to-fabric bond, a sandy, low strength outer surface of concrete and a concrete lining or mat which will exhibit low abrasion resistance and durability.

Finishing (Enviromat EL & EB Linings only)

After the concrete lining has been filled and the concrete has set, the large single-layer areas should be cut out and the resulting open areas filled with void filler to the top of the concrete lining. The void filler material should consist of topsoil, seed and fertilizer in accordance with the Contract Specifications. At no time should more than 200 linear feet (152.5 m) of concrete lining be exposed unfilled.

Below the water line, the void filler material should consist of well-graded aggregate with a maximum size of 1 inch (25 mm). At no time shall more than 500 linear feet (150 m) of Enviromat be exposed unfilled.

Steel Anchor Rods

Where required in the Contract Drawings and Specifications, steel anchor rods should be installed at designated centers along the fabric-formed concrete lining or mat to increase its resisting force (Fig. 55). The diameter of the anchor rods is selected to provide the supplemental shear strength required for the installed area of lining or mat. The threaded anchor rods should be grades 40 or 50 and a 6 inch (152 mm) square washer and nut are placed at the end of each anchor. Typically, the total length of the anchor rod is the sum of the embedment depth, the average thickness of the lining or mat, plus 6 inches (152 mm). The embedment depth of the anchor rod must be sufficient to resist the pullout force applied in line with the rod. The depth is dependent upon the concrete used in the anchor block and the type of soil. *For most conditions, an embedment depth of 24 inches (610 mm) is sufficient.*

Anchor rods are installed by excavating a 6 inch (152 mm) diameter anchor hole with a post digger or auger, filling the hole with concrete, and inserting the anchor rod. Once the concrete has set, a geotextile filter fabric and the fabric form are placed and the anchor rod is forced through the filter fabric and both layers of the fabric form. The form is filled with fine aggregate concrete and allowed to set for a minimum of one hour. A washer is then placed over the exposed end of the anchor rod, and a nut is installed snugly to secure the washer to the top of the lining or mat.

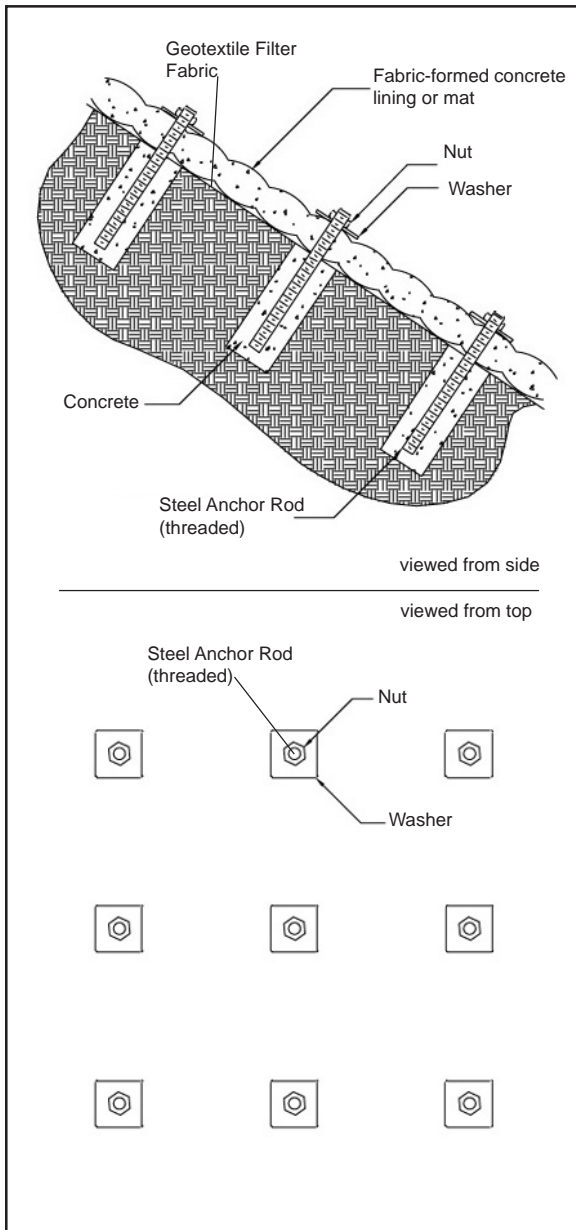

Figure 55

HYDROCAST™ Armor Units

HYDROCAST fabric forms provide an effective forming system for casting large concrete armor units in place, underwater or in-the-dry. Fabric formed concrete armor units meet the requirements for a reliable and economical cast-in-place alternative to heavy quarry stone (rip rap) or large precast concrete blocks. They are used for the construction and repair of erosion control structures such as breakwaters, dikes, seawalls, groins, and jetties as well as for foundation structures (such as underwater pipelines), footing supports, and other hydraulic and marine structures. They are also extensively used by departments of transportation to prevent or repair scour at bridge piers and abutments. Figures 56, 57, 58, and 59 illustrate typical applications of fabric-formed armor units.

When filled with a fine aggregate or conventional concrete they form individual, cylindrical units that assume a flattened cross section, as demonstrated in figures 56 and 57. The concrete is pumped under pressure, resulting in rapid concrete stiffening, improved concrete properties [e.g., “case hardening” of the outer 3 to 6 inches (75 to 150 mm) of concrete], strength and durability. They have the required mass and stability to withstand the severe forces of large storm waves and rapidly flowing water. The concrete armor units may be placed side-by-side or stacked to form an inherently interlocked structure. Since they are concrete filled in place, they can adapt to variations in the subgrade or bottom contours.

Fabric-formed concrete armor unit installations do not require dewatering, a crucial advantage in emergency repair of bridge piers scoured by flood waters. Fabric forms can be positioned and filled with concrete from the surface in shallow water or by divers in deeper water. Unlike quarry stone or precast concrete blocks, they do not require placement by heavy cranes working from the land or from barges.

Fabrication of HYDROCAST Armor Unit Forms

The specially woven double-layer fabric is joined by a perimeter of interwoven and/or sewn seams to form a large fabric form envelope. Fabric used in the construction of armor units shall conform to the physical properties shown in Table 11.0. All sewn seams are folded and sewn with a double line of Type 401 double-lock stitches. The sewing thread used for seaming shall be nylon or polyester. Each fabric form is provided with one or more self-closing inlet valves to accommodate a concrete injection pipe.

HYDROCAST Unit Dimensions

Fabric-formed concrete armor units may be cast in a wide range of sizes and shapes. Geostar’s technical staff accurately calculates the length, width and height of the concrete armor unit and the volume of concrete per measure of unit length with the aid of computer programs. Tables 12.0 and 13.0 provide typical dimensions and volumes of fabric-formed concrete armor units, both filled and unfilled.

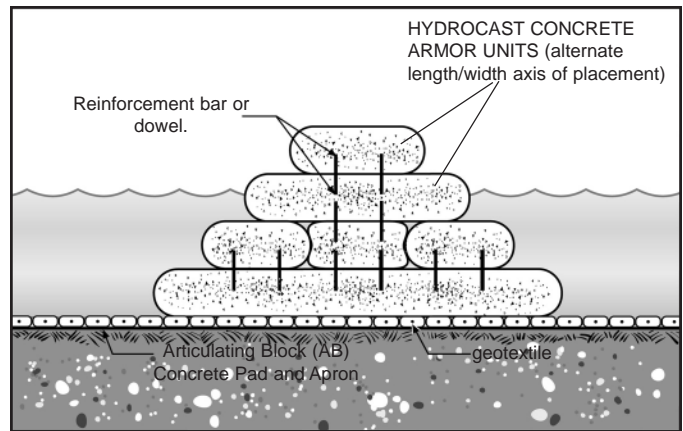

Figure 56 - Groin

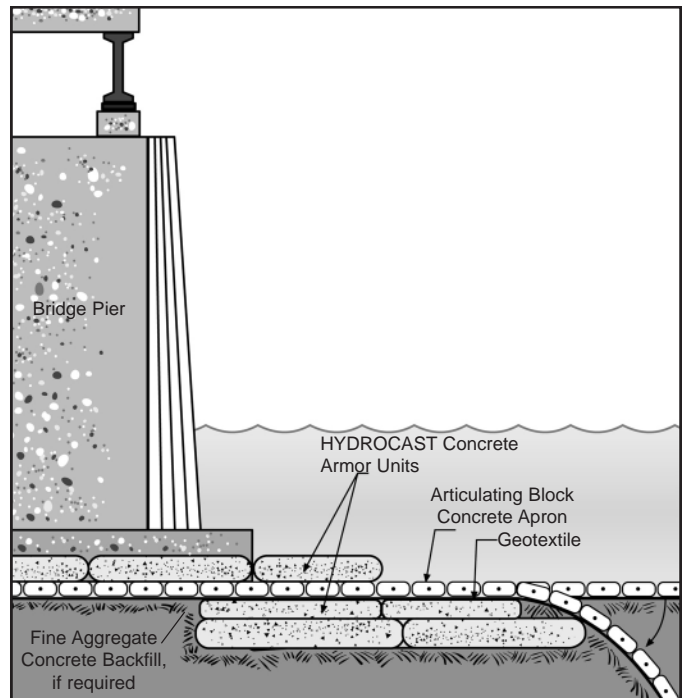

Figure 57 - Repair of Scoured Bridge Pier

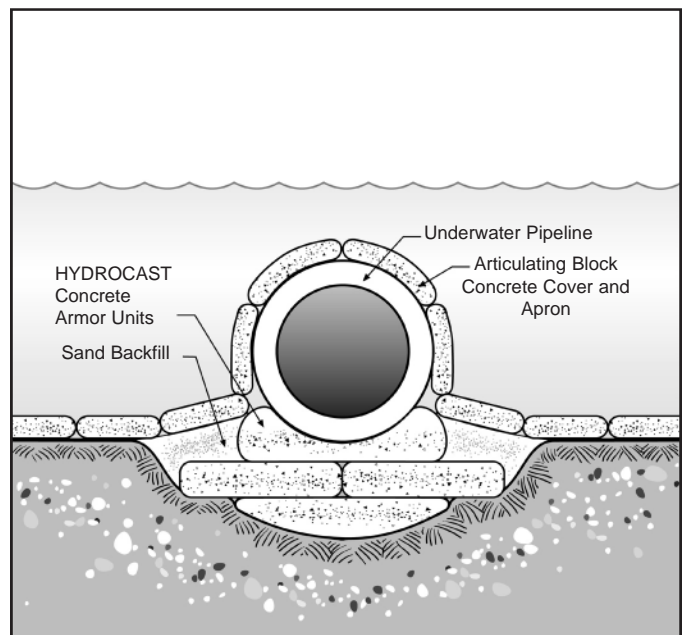

Figure 58 - Pipeline Saddle and Cover

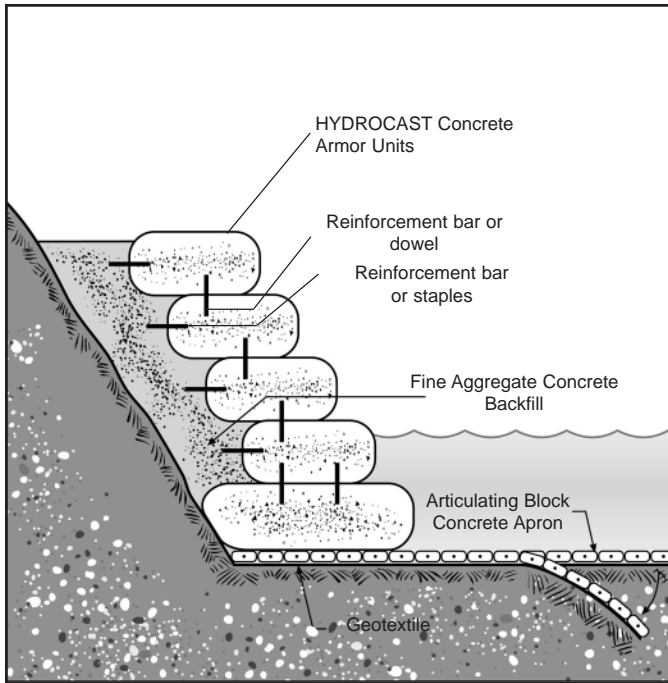

Figure 59 - Seawall or Shoreline Protection

Custom Designs

In addition to the wide range of standard rectangular fabric formed concrete armor units, Geostar's designers can also design custom shaped forms to accommodate underwater pipelines, footers and other objects (Fig. 60).

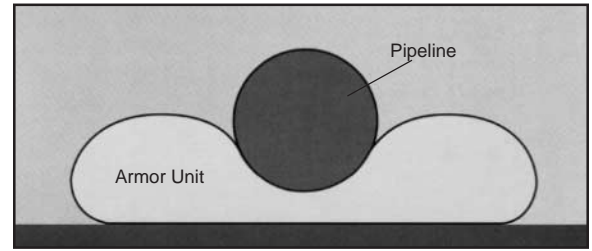

Figure 60

Table 11.0 - Property Requirements - HYDROCAST Armor Unit Fabric ^{1, 2}			
Property	Test Method	Units	Values
Physical:			
Composition of Yarns			Nylon or polyester
Mass Per Unit Area (double-layer)	ASTM D 5261	oz/yd ² (g/m ²)	14 (470)
Thickness	ASTM D 5199	mils (mm)	28 (0.7)
Mill Width		in (m)	76 (1.92)
Mechanical:			
Wide-Width Strip Tensile Strength - Machine/Cross	ASTM D 4595	lbf/in (kN/m)	190 (33.2) / 140 (24.5)
Elongation at Break - Machine/Cross	ASTM D 4595	%	20 / 30
Trapezoidal Tear Strength - Machine/Cross	ASTM D 4533	lbf (N)	180 (800) / 115 (510)
Hydraulic:			
Apparent Opening Size (AOS)	ASTM D 4751	U.S. Standard Sieve (mm)	60 (0.250)
Flow Rate	ASTM D 4491	gal/min/ft ² (l/min/m ²)	50 (2035)

Notes:

1. Conformance of fabric to specification property requirements shall be based on ASTM D 4759, "Practice for Determining the Specification Conformance of Geotextiles."
2. All numerical values represent minimum average roll values (i.e., average of test results from any sample roll in a lot shall meet or exceed the minimum values). Lots shall be sampled according to ASTM D 4354, "Practice for Sampling of Geosynthetics for Testing."
3. Yarns used in fabric construction shall not contain partially oriented (POY), draw-textured, and or staple yarns.

Ordering Fabric Forms

The ordering of fabric forms should be done in advance of the start of the project, to allow time for the preparation, submittal and approval of layout and shop drawings. Project plans and specifications should be submitted to Geostar's technical support department. Trained technicians translate the site plans, grades, elevations, contours and construction details into CAD systems where they develop cost-effective take-offs and fabric-formed concrete armor unit layout drawings, tailored to the project's design requirements. This design technique and CAD layout verification procedure will assure accurate dimensioning and quantity material takeoffs.

The forms are over-dimensioned, in both length and width, to make allowance for form contraction as they are filled with fine aggregate concrete. Contraction factors are a function of site conditions and finished armor unit dimensions. The definition of "contraction factor" is the length or width of fabric form required divided by the corresponding length or width of the area to be covered by the concrete armor

Manufacturer's Certification:

The manufacturer of the fabric forms should submit a manufacturer's certificate stating that the supplied fabric forms meet the criteria of the manufacturer's specifications, as measured in full accordance with the test methods and standards referenced. The certificates should include the following information about each fabric form shipment:

- *Manufacturer's name and current address*
- *Full product name*
- *Style and product code number*
- *Form number(s)*
- *Polymer types*
- *Manufacturer's certification statement*

Table 12.0 - Unfilled Fabric Form Width/Length to Filled Thickness and Width/Length of Armor Unit																	
Filled Thickness	Width/Length of Unfilled Fabric Forms																
inches meters	24 0.61	30 0.76	36 0.91	42 1.07	48 1.22	54 1.37	60 1.52	66 1.68	72 1.83	78 1.96	84 2.13	90 2.29	96 2.44	102 2.59	108 2.74	114 2.90	120 3.05
	Width/Length of Filled Fabric Forms - Inches (Meters)																
6 0.15	21 0.52	27 0.68	33 0.83	39 0.98	45 1.13	51 1.28	57 1.14	63 1.59	69 1.74	75 1.89	81 2.05	87 2.20	93 2.35	99 2.50	105 2.66	111 2.81	117 2.96
9 0.23	19 0.48	25 0.63	31 0.78	37 0.94	43 1.09	49 1.24	55 1.39	61 1.55	67 1.70	73 1.85	79 2.00	85 2.16	91 2.31	97 2.46	103 2.61	109 2.77	115 2.92
12 0.30	17 0.44	23 0.59	29 0.74	35 0.89	41 1.05	47 1.20	53 1.35	59 1.50	65 1.66	71 1.81	77 1.96	83 2.11	89 2.26	95 2.42	101 2.57	107 2.72	113 2.87
15 0.38		21 0.52	27 0.68	33 0.83	39 0.98	45 1.13	51 1.28	57 1.44	63 1.59	69 1.74	75 1.89	81 2.05	87 2.20	93 2.35	99 2.50	105 2.66	111 2.81
18 0.46			26 0.65	32 0.81	38 0.96	44 1.11	50 1.26	56 1.42	62 1.57	68 1.72	74 1.87	80 2.03	86 2.18	92 2.33	98 2.48	104 2.63	110 2.79
21 0.53				30 0.76	36 0.92	42 1.07	48 1.22	54 1.37	60 1.52	66 1.68	72 1.83	78 1.98	84 2.13	90 2.29	96 2.44	102 2.59	108 2.74
24 0.61					34 0.87	40 1.02	46 1.18	52 1.33	58 1.48	64 1.63	70 1.79	76 1.94	82 2.09	88 2.24	94 2.40	100 2.55	106 2.70
27 0.69						39 0.98	45 1.13	51 1.29	57 1.44	63 1.59	69 1.74	75 1.90	81 2.05	87 2.20	93 2.16	99 2.31	105 2.66
30 0.76							43 1.09	49 1.24	55 1.39	61 1.55	67 1.70	73 1.85	79 2.00	85 2.16	91 2.31	97 2.46	103 2.61
33 0.84								47 1.20	53 1.35	59 1.50	65 1.66	71 1.81	77 1.96	83 2.11	89 2.27	95 2.42	101 2.57
36 0.91									51 1.31	57 1.46	63 1.61	69 1.76	75 1.92	81 2.07	87 2.22	93 2.37	99 2.53
39 0.99										56 1.42	62 1.57	68 1.72	74 1.87	80 2.03	86 2.18	92 2.33	98 2.48
42 1.07											60 1.53	66 1.68	72 1.83	78 1.98	84 2.14	90 2.29	96 2.44
45 1.14												64 1.63	70 1.79	76 1.94	82 2.09	88 2.24	94 2.40
48 1.22													69 1.74	75 1.90	81 2.05	87 2.20	93 2.35

Note: Values shown are typical and will vary with weight of concrete and field conditions.

unit. An example contraction factor calculation is given on page 36 of this manual.

Layout drawings showing the field assembly of the fabric form armor units for the entire project are prepared. The drawings identify each armor unit, its location and sequence of installation, pertinent elevations and coordinates, direction of flow, anticipated water levels, and structures such as roads, curbs, bridges, intake and discharge pipes, culverts, ramps and other existing and future structures that may effect the placement of the fabric-forme d armor units.

Labeling:

The fabric forms should be labeled as per ASTM D 4873, "Guide for Identifying, Storage and Handling of Geosynthetics Rolls".

A submittal package which includes shop and layout drawings, a list of numbered fabric forms, form dimensions and areas, and a manufacturer's certification is assembled and forwarded to the contractor for submittal to the project engineer. Upon the project engineer's approval of the submittal package, Geostar's manufacturing department commences fabric form fabrication and confirms the delivery schedule.

Table 13.0 - Unfilled Fabric Form Width to Filled Volume of Armor Unit																	
Filled Thickness	Width of Unfilled Fabric Forms																
inches	24	30	36	42	48	54	60	66	72	78	84	90	96	102	108	114	120
meters	0.61	0.76	0.91	1.07	1.22	1.37	1.52	1.68	1.83	1.96	2.13	2.29	2.44	2.59	2.74	2.90	3.05
	Volume of Concrete - Cubic Feet per Foot of Length (Cubic Meter per Meter of Length)																
6 0.15	0.8 0.07	1.1 0.10	1.3 0.12	1.6 0.15	1.8 0.17	2.1 0.20	2.3 0.21	2.6 0.24	2.8 0.26	3.1 0.29	3.3 0.31	3.6 0.34	3.8 0.35	4.1 0.38	4.3 0.40	4.4 0.41	4.7 0.44
9 0.23	1.1 0.10	1.4 0.13	1.8 0.17	2.2 0.20	2.6 0.24	2.9 0.27	3.3 0.31	3.7 0.34	4.1 0.38	4.4 0.41	4.8 0.45	5.2 0.48	5.6 0.52	5.9 0.55	6.3 0.59	6.7 0.62	7.1 0.66
12 0.30	1.2 0.11	1.7 0.16	2.2 0.20	2.7 0.25	3.2 0.30	3.7 0.34	4.2 0.39	4.7 0.44	5.2 0.48	5.7 0.53	6.5 0.60	6.7 0.62	7.2 0.67	7.7 0.72	8.2 0.76	8.7 0.81	9.2 0.86
15 0.38		1.9 0.18	2.5 0.23	3.1 0.29	3.8 0.35	4.4 0.41	5.0 0.47	5.6 0.52	6.3 0.59	6.9 0.64	7.5 0.70	8.1 0.75	8.8 0.82	9.4 0.87	10.0 0.93	10.6 0.99	11.3 1.05
18 0.46			2.7 0.25	3.5 0.33	4.2 0.39	5.0 0.47	5.7 0.53	6.5 0.60	7.2 0.67	8.0 0.74	8.7 0.81	9.5 0.88	10.2 0.95	11.0 1.02	11.7 1.09	12.5 1.16	13.2 1.23
21 0.53				3.7 0.34	4.6 0.43	5.5 0.51	6.3 0.59	7.2 0.67	8.1 0.75	9.0 0.84	9.8 0.91	10.7 0.99	11.6 1.08	12.5 1.16	13.3 1.24	14.2 1.32	15.1 1.40
24 0.61					4.9 0.46	5.9 0.55	6.9 0.64	7.9 0.73	8.9 0.83	9.9 0.92	10.9 1.01	11.9 1.11	12.9 1.20	13.9 1.29	14.9 1.39	15.9 1.47	16.9 1.57
27 0.69						6.2 0.58	7.3 0.68	8.4 0.78	9.5 0.88	10.7 0.99	11.8 1.10	12.9 1.20	14.0 1.30	15.2 1.41	16.3 1.52	17.4 1.62	18.5 1.72
30 0.76							7.6 0.71	8.8 0.82	10.1 0.94	11.3 1.05	12.6 1.17	13.8 1.28	15.1 1.40	16.3 1.52	17.6 1.64	18.8 1.75	20.1 1.87
33 0.84								9.2 0.86	10.6 0.99	11.9 1.11	13.3 1.24	14.7 1.37	16.1 1.50	17.4 1.62	18.8 1.75	20.2 1.88	21.6 2.00
36 0.91									10.9 1.02	12.4 1.15	13.9 1.29	15.4 1.43	16.9 1.57	18.4 1.71	19.9 1.85	21.4 1.99	22.9 2.13
39 0.99										12.8 1.19	14.5 1.35	16.1 1.50	17.7 1.65	19.3 1.79	21.0 1.95	22.6 2.10	24.2 2.25
42 1.07											14.9 1.39	16.6 1.54	18.4 1.71	20.1 1.87	21.9 2.04	23.6 2.20	25.4 2.36
45 1.14												17.1 1.59	19.0 1.77	20.8 1.93	22.7 2.11	24.6 2.28	26.5 2.46
48 1.22													19.4 1.80	21.4 1.99	23.4 2.18	25.4 2.36	27.4 2.55

Note: Values shown are typical and will vary with weight of concrete and field conditions.

Proper Storage and Handling of Fabric Forms

Fabric forms are delivered at the job site in trailers or ocean containers. Fabric forms are stacked in a manner that assures ease of unloading. Standard 40 ft (12 m) long trailers or containers hold up to 215,000 ft² (20,000 m²) of fabric forms per load.

Armor unit fabric forms are normally shipped boxed. Alternatively they may each be wrapped in two layers of protective cover. The first layer (inner layer) is a waterproof, opaque, plastic cover the second (outer layer) is a woven, abrasion resistant, fabric cover.

When fabric forms are to be inventoried at the job site, they should be kept dry and remain boxed so that they are protected from the elements during storage and handling. If stored outdoors, they should be elevated and protected with a waterproof cover that is opaque to ultraviolet light. Care should be taken not to damage the fabric forms during unloading, storage and handling. *The contractor should unload the fabric forms by hand or with a forklift or similar equipment. When lifting fabric forms make sure that workers have proper back support.*

Contraction of HYDROCAST Armor Units

The definition drawing, Figure 61, illustrates the change in width that occurs when a fabric form is filled with concrete to form an armor unit. Table 12.0 is a guide in determining the required dimensions of an unfilled fabric form for casting a given concrete armor unit size. Table 13.0 is a guide in determining the volume of concrete required to fill a fabric form of given dimensions. The dimensions and volumes are calculated from dimensional equation and may not reflect field conditions.

Equations for determining the filled width and length of HYDROCAST Fabric Forms:

$$W = W_f + 0.57T$$

$$L = L_f + 0.57T$$

Where:

W = Width of unfilled fabric form

W_f = Width of filled fabric form

L = Length of unfilled fabric form

L_f = Length of filled fabric form

T = Thickness of filled fabric form

Equations for determining the volume of concrete required for filling HYDROCAST Fabric Forms:

$$V_f = 0.785 T^2 + T (W_f - T)$$

$$V_t = (V_f)(L_f)$$

Where:

V_f = Volume of concrete per unit length of filled armor unit

V_t = Total Volume of the filled armor unit

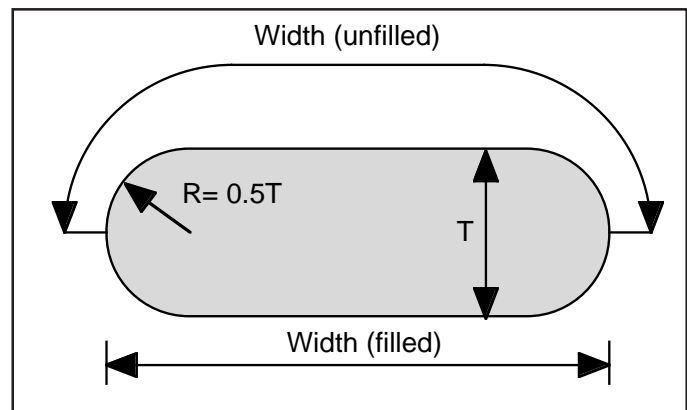

Figure 61

Example Calculation:

Determine the unfilled dimensions and filled volume for a 10 ft (3 m) long by 62 inches (1.57 m) wide by 18 inches (0.46 m) thick armor unit.

From equations:

$$W = W_f + 0.57T = 62 \text{ in} + 0.57 \times 18 \text{ in} = 72 \text{ in} (1.83 \text{ m})$$

$$L = L_f + 0.57T = 10 \text{ in} \times 12 \text{ in/ft} + 0.57 \times 18 \text{ in} = 130 \text{ in or } 11 \text{ ft}$$

$$V = V_f L_f = 7.3 \text{ ft}^2 \times 10 \text{ ft} = 73 \text{ ft}^3 \text{ or } 2.7 \text{ yd}^3 (2.1 \text{ m}^3)$$

From tables:

From Table 12.0 - For a filled width of 62 in (1.57 m), with a thickness of 18 in (0.46 m) and a length of 10 ft (3 m), a fabric form 11 ft long by 72 in wide would be selected.

From Table 13.0 - The volume of a 62 in (1.57 m) wide, by 18 in (0.46 m) thick and 10 ft (3 m) long fabric form would be approximately 72 ft³ or 2.7 yd³.

Note: The concrete-filled thickness of the fabric form should be not more than 70 percent of the width of the unfilled fabric form.

Installation of HYDROCAST Armor Units

Equipment and Tools

Because of the simple installation procedure for HYDROCAST Armor Units, a nominal amount of tools and equipment are required. We suggest that the contractor have on hand the following:

Tools:

Surveyor's level and rod	Shovels
Rakes	Hammers
Stakes	String line
Rubber boots and gloves	Pail
Safety glasses or goggles	Scissors
Trowels	

Equipment:

- Small line concrete pump
- Concrete pump hose - 2 inch (50 mm) diameter
- Injection pipe - 2 inch (50 mm) diameter
- Hand-held sewing machine (electric or air powered) with speed control
- Extension cord (if electrical equipment is used)
- Electric generator with ground fault circuit breaker
- Air compressor (for air powered sewing machine)
- Small, walk-behind flat or vibratory compactor for soil compaction

A list of equipment manufacturers is provided in the appendices. However, Geostar Corporation makes no warranty nor guarantees the performance of equipment provided by another manufacturer.

Sequence of Armor Unit Installation

Once the area to be protected has been excavated, graded and compacted to the lines and grades specified in the Contract Drawings and Specifications, an installation crew, filter fabric (if required), fabric forms, and the tools and equipment listed above should be mobilized to the job site. *Freshly excavated and graded slopes are highly subject to erosion and should be protected from water runoff, flowing water and waves.*

Depending on the location of the area, dimensions, and the rate of subgrade preparation, installation rates of as much as 15 yd³ (11.5 m³) of fine aggregate concrete per hour can be achieved by a crew of 3 or 4 laborers, a concrete pump operator and a supervisor.

Establish the starting point.

The first step in the installation of fabric-formed concrete armor units is to establish a starting point. If a working point and direction of placement are shown on the Contract Drawings this should be the starting point. If this is not the case, it is the customary practice for channels, streams and rivers to work from the upstream end of the project to the downstream end. In this manner the flow of the water will tend to spread

the fabric forms out ahead of the finished work and the finished concrete armor unit is protected from undercutting. For inland and coastal shorelines it is customary practice to install the first course of armor units then proceed to succeeding courses. *Fabric form armor unit layout drawings, available from Geostar Corporation, will recommend starting points and directions of placement for the project.*

Establish the alignment lines

Once a starting point has been established a surveyor's level should be used to determine the longitudinal and slope alignment lines of the fabric-formed concrete armor units. String lines should then be placed along the respective alignment lines and staked. Generally, the alignment lines are offset, by a measured distance, to the opposite side of any trench or a minimum of 5 feet (1.5 m) in order not to interfere with the work area. *The method of establishing reference points and lines should be left to the discretion of the contractor.*

Placement of the filter fabric, if required

Under certain soil conditions or if called for in the Contract Drawings and Specifications, it will be necessary to place filter fabric and/or a granular sublayer under the fabric forms to guarantee that soil is not piped through any spaces between the armor units. Filter fabric should be selected and placed in accordance with the Contract Drawings and Specifications or in the absence of such directions in accordance with the manufacturer's guidelines. *Filter fabrics and their installation are discussed, in brief, earlier in this manual (page 7).*

Placement of the first course of armor unit fabric forms

The prefabricated armor unit forms are folded and marked with the appropriate form numbers and dimensions at the factory for easy identification, location and installation.

The first armor unit fabric form, in the first course, should be carefully placed at the designated starting point and unfolded into position (Fig 62). Special care should be taken to assure that the sides and ends of the form are exactly parallel to their respective alignment lines.

Armor unit fabric forms should be placed loosely, but without folds, to allow for proper filling with fine aggregate concrete. The extra fabric provided for form contraction should be extended. Forms that are stretched or taut will not permit the required form contraction, therefore the fabric forms will not fill to their required thicknesses. For example, a 72 inch by 120 inch (183 cm x 305 cm) form is to be filled to a thickness of 30 inches (76 cm). When filled with fine aggregate concrete to this thickness, the width and length of the form will contract by approximately 57% of the thickness, giving a finished armor unit dimension of 55 inches x 103 inches (139 cm x 261 cm). Adjacent armor units (of the same dimensions

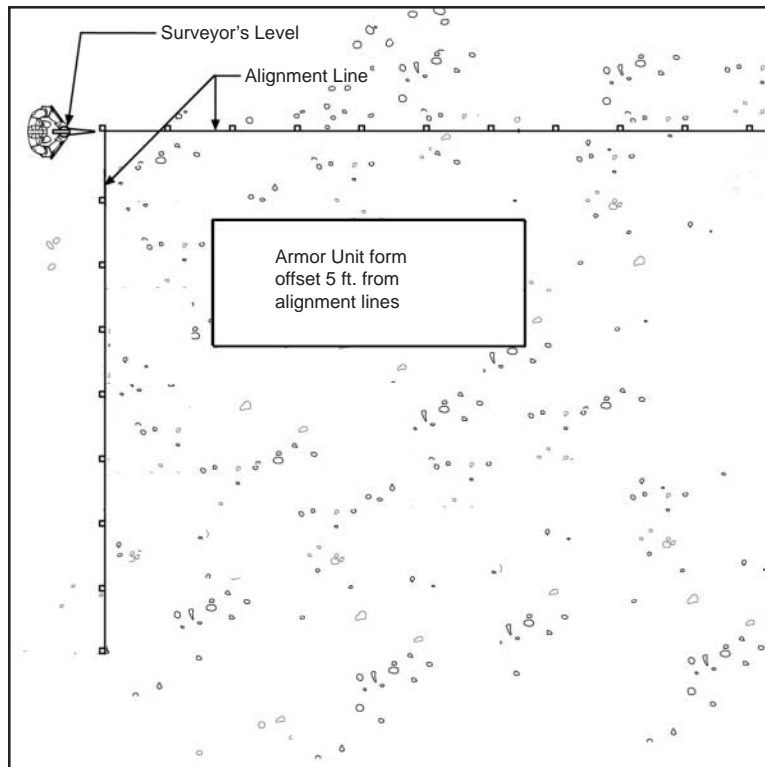

Figure 62

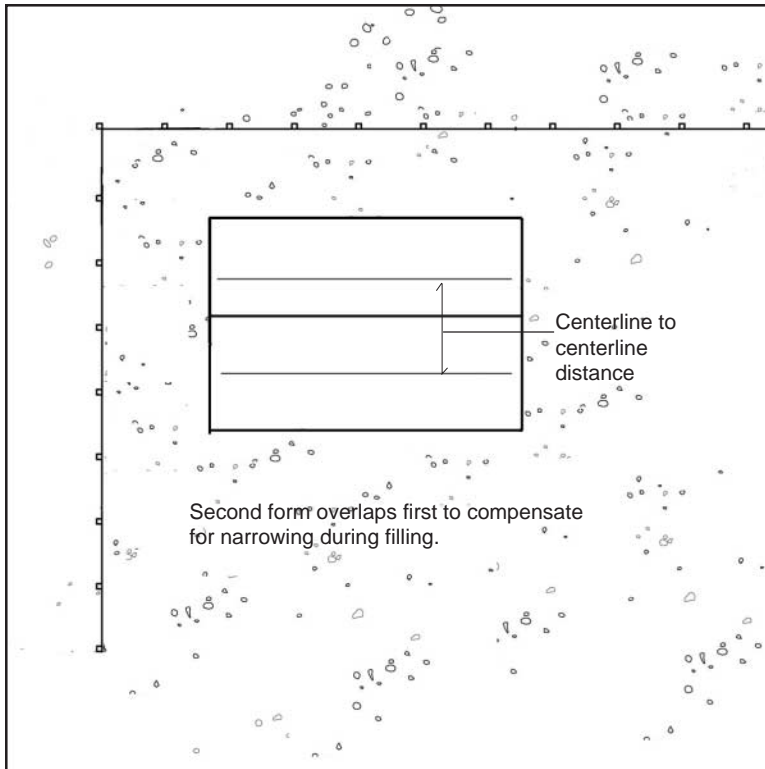

Figure 63

used in this example) should therefore be placed with their centers 17 inches (43 cm) closer together than called for by the unfilled form dimensions.

The second armor unit form in the first course should be placed alongside the first form so that the centerline to centerline distance equals that of the calculated armor unit width after contraction, as shown in Figure 63. After the second armor unit form has been positioned, the alignment of the forms should be checked.

The remaining armor unit forms in the first course should be placed side-by-side in the same manner. The alignment of the forms should be checked periodically since small errors in alignment can progress in severity. Armor unit form alignment is important in providing a uniform and attractive appearance in the finished installation.

Armor unit form placement should precede concrete filling by no more than the distance that can be completed in one day. Where the forms may be exposed to flowing water or wave action, each form should be filled with fine aggregate concrete prior to placement of the adjacent form.

Placement of the second course of armor unit fabric forms

The second course of armor unit forms should be placed atop the fine aggregate concrete filled first course. (See Sequence of Fine Aggregate Concrete Pumping.) The center line of the first form in the second course is positioned directly over the abutting edges of the first two armor units in the first course, as shown in Figure 64. The staggering of the centerlines of the armor units in vertically adjacent courses encourages “nesting” of armor units and facilitates alignment. The remaining forms in the second course should be placed side-by-side in the same manner as the first course. Once again, check alignment periodically since small errors can progress in severity.

When constructing structures subject to wave action, the armor units should be aligned with their long axis facing the principal direction of wave attack.

Underwater placement of fabric-formed armor units may require the use of divers. The divers can prepare the finished grading, inspect the area to be protected, and position and secure the filter fabric and fabric forms. The securing of the forms may require sand bags or weights.

A small quantity of bulk (uncut and unassembled) form fabric should be ordered for each project. The fabric can be used for special field tailoring. At least one half a roll, about 900 ft² (84 m²) of bulk fabric, is recommended.

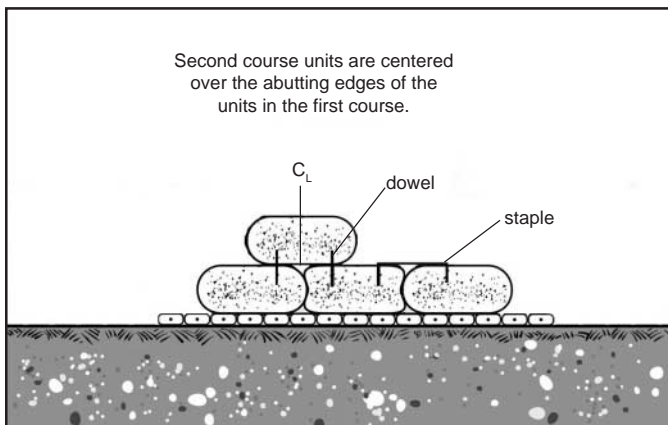

Figure 64

Sequence of Fine Aggregate Concrete Pumping

Ordering fine aggregate concrete

Fine aggregate concrete is generally delivered to the job site in ready-mix trucks. The order for concrete should be placed a least one day prior to its scheduled delivery to the job site. The concrete supplier should be instructed to fill the water tank of each truck with mix water. *It is common that the first few loads delivered to the job site will not be fluid enough for pumping and will require the addition of mix water.* In order to avoid presetting of the fine aggregate concrete it is recommended that the concrete be delivered in loads of no more than 8 yd³ (6 m³). At a minimum, the first load of each day should be checked with a standard flow cone for consistency, in accordance with ASTM D 6449. *The addition of pea gravel to the mix may reduce the cost of materials with a slight increase in labor costs. When pumping concrete with pea gravel, the diameter of the pump hose should be increased.*

Securing the armor unit forms

Beginning at the designated starting point the installation crew should check and adjust the armor unit forms to assure that they are in alignment. After the forms have been properly adjusted, fine aggregate concrete is pumped into forms. *It must be emphasized that care should be exercised in the alignment and securing of the first course of armor units. This will ensure the aesthetics of the concrete armor units and also hasten the installation of subsequent courses.*

Inserting the fine aggregate concrete injection pipe

Fine aggregate concrete should be pumped into the fabric form armor unit by inserting the injection pipe through a self-closing "pocket type" filling valve in the upper layer of the fabric. A tight seal is made when the injection pipe is inserted into the valve. When the pipe is withdrawn, the valve shuts.

Filling the first fabric form armor unit with fine aggregate concrete

Starting at the first fabric form armor unit, the injection pipe should be inserted into the self closing filling valve. The form should be filled by pumping fine aggregate concrete into the form. The fine aggregate concrete should fill the center and corners of the form, proceeding gradually to the specified thickness. *Pressure from the concrete fill helps close the filling valve.*

The injection pipe should then be moved to the adjacent armor unit form and inserted into the filling valve. Once again, the previous pumping procedure should be repeated until this form has been filled to its specified thickness.

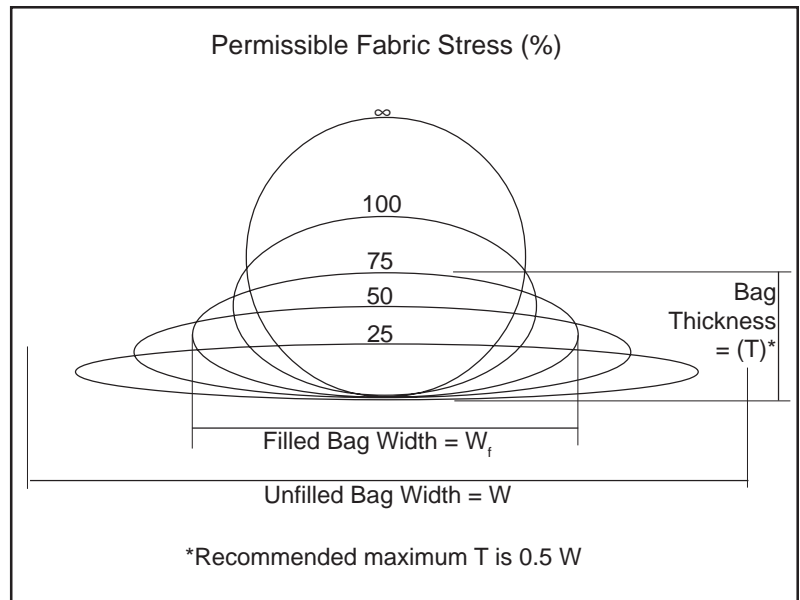

Figure 65

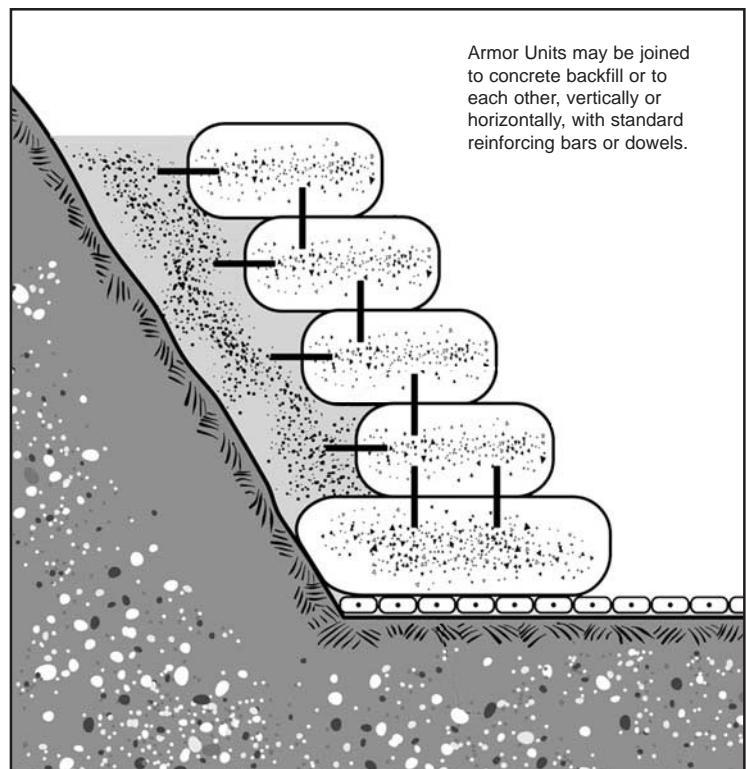

Figure 66

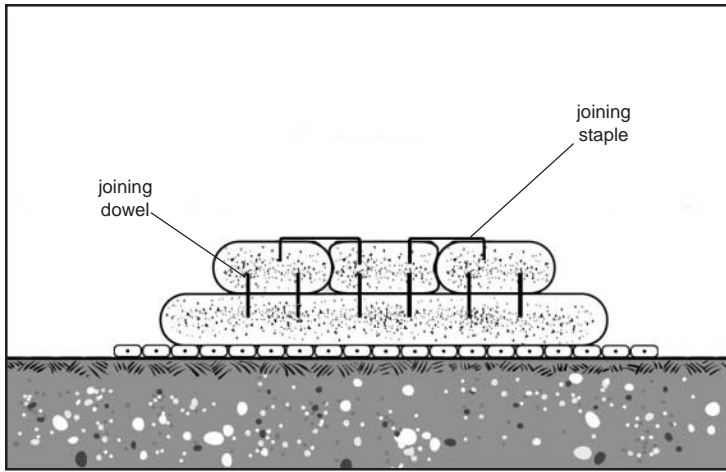

Figure 67- Typical cross section

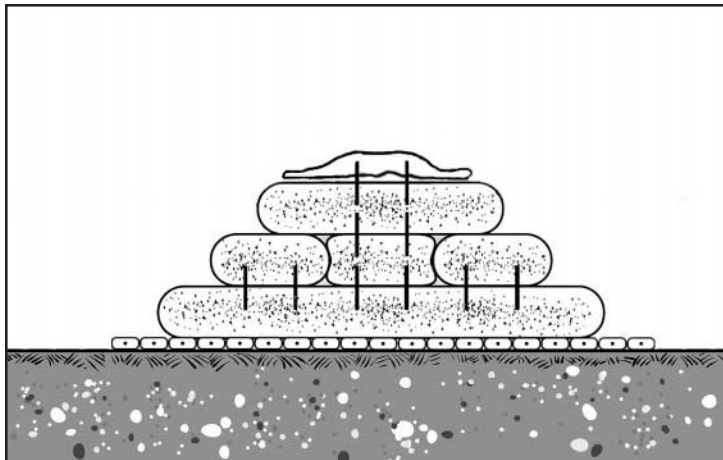

Figure 68- Armor Unit form ready for filling

Overpressuring of fabric forms

Care must be taken when pumping fabric forms to assure that the fabric is not over pressurized. Over pressurization may cause bursting of seams. Please refer to Table 12.0 for recommended filling thicknesses per width. See also Figure 65 for fabric stress at differing fill geometries.

Connecting fine aggregate concrete armor units

Armor units are easily joined by inserting steel reinforcement bars, "dowels" or "staples" as suggested in Figures 66 and 67. When connecting vertically adjacent courses of armor units by inserting dowels, first force the pointed ends of the reinforcement bars through the fabric and into the fresh concrete of the filled armor units. Dowels or staples shall be inserted into the filled unit(s) not less than one half hour and not more than one hour after filling of the unit, unless directed otherwise by the Engineer. The forms in the succeeding course are then threaded over the exposed reinforcement bar ends. The dowels are then forced through the bottom layer of the vertically adjacent fabric form (Fig. 68), and the form is then filled with fine aggregate concrete.

Armor units may be connected side-by-side by inserting staples; bend the reinforcement bars into an elongated "U" shape and force the pointed ends of the reinforcement bars through the fabric and into the fresh concrete of the filled armor units. The dowels and staples assist in holding the forms in place during filling and maintaining the alignment of the armor unit structure. Abutting armor units, if placed laterally, may be installed immediately after placement of the preceding unit(s). If an armor unit is to bear on previously installed units, the lower units must be allotted a minimum of four hours of cure time before beginning installation of a succeeding, vertically adjacent course of armor units.

Where required, reinforcement bar cages are installed in the forms through openings in the forms. The form opening is closed before filling by means of a zipper or a portable sewing machine. Reinforcement bar cages are suspended by tie wires from the upper side of the form to assure centering.

Circumferential straps may be attached to armor unit forms as thickness indicators to facilitate the filling of forms underwater. Slight depressions formed by the straps in the surface of the armor unit indicate to the diver, working by touch, that the form has been filled to the specified thickness.

Circumferential straps of predetermined circumferences and spacing, with or without external restraining reinforcement bars, permit the casting of tapering or irregularly shaped armor units.

Filling remaining fabric form armor units with fine aggregate concrete

If care has been taken in positioning the forms and in concrete filling the first course of armor unit forms, little, if any, adjustment of subsequent courses should be required. However, form alignment should be checked periodically since small errors in alignment can progress in severity. Periodically check the location of the forms with an instrument to assure that proper alignment is being maintained.

Special Considerations

Pipes, piles, culverts, trees, and other appurtenances

Armor unit forms should be tailored in the field to fit around pipes, culverts, trees, and other appurtenances. A form may be field cut and sewn or bulk fabric may be fabricated to fit snugly around the object.

Backfilling and compaction of trenches

The backfilling and compaction of open excavations should not begin until at least one hour after filling the adjacent concrete armor unit. Backfill material may be either select bedding materials or fine aggregate concrete. The excavations should be backfilled as shown on the Contract Drawings. *The open excavations behind completed sections of armor units should be backfilled and compacted by the end of the work day.*

Foot traffic

Foot traffic on the freshly pumped fine aggregate concrete armor unit should be avoided for a period of not less than one hour after concrete injection or until the concrete is resistant to indentation. Should traffic be unavoidable, the contractor should place board walks along the finished filled concrete areas. This will reduce the amount of objectionable indentation. *Footprints will leave permanent impressions in the installed fabric-formed concrete armor units.*

Cleanup

Any fine aggregate concrete that may spill on top of the fabric-formed concrete armor unit should be picked up by hand or trowel and the surface smoothed by cloth or broom. Such unnecessary spillage of concrete will cause an unsightly appearance. This is particularly important along the top of the final course of armor units.

The installation crew should be instructed to carefully "kink" the concrete pump hose when it is moved from one injection point to another or to place the end of the concrete injection pipe in a pail when moving the concrete pump hose.

The freshly pumped fabric-formed concrete units should never be washed (sprayed) under pressure with water in an effort to clean or remove spills from its surface. A wet cloth should be used for clean up and spill removal.

The cement film that impregnates the fabric forms provides a bond between the fabric form and the concrete fill and a degree of protection against ultraviolet degradation of the fabric. Should this film be removed by washing the uncured concrete armor units, cement may be also washed out from beneath the layer of fabric. The result would be a loss of concrete-to-fabric bond, a sandy, low strength outer surface of concrete and a concrete armor units which will exhibit low abrasion resistance and durability.

APPENDIX 1 - CONCRETE PUMPING EQUIPMENT MANUFACTURERS

Manufacturer	Mayco Pump A Multiquip Company P.O. Box 6254 Carson, CA 90749 USA Tel: 310/537-3700 800/537-3927 Fax: 310/537-3927	Olin Engineering 15592 Computer Lane Huntingdon Beach, CA 92649 USA Tel: 714/897-1230 Fax: 714/892-9268	Schwing America, Inc Small Line Division 5900 Centerville Road St. Paul, MN 55127 USA Tel: 612/429-8651 Fax: 612/429-8616
Model	C - 30HD	525	P - 88
Performance			
Concrete Output	25 yd ³ /hr (19 m ³ /hr)	32 yd ³ /hr (24 m ³ /hr)	25 yd ³ /hr (19 m ³ /hr)
Concrete Pressure	-	750 psi (53 Bar.)	500 psi (35 Bar.)
Horizontal Pumping Distance	500 ft (150 m)	800 ft (244 m)	500 ft (150 m)
Maximum Aggregate Size	0.5 in (13 mm)	0.5 in (13 mm)	0.5 in (13 mm)
Pump			
Volume Control	Variable - Adjustable stroke and speed	Variable - Adjustable stroke and speed	Variable - Adjustable stroke and speed
Concrete Cylinder Diameter	6 in (150 mm)	5 in (127 mm)	6 in (150 mm)
Concrete Cylinder Stroke	-	12 in (305 mm)	7.75, 6.5, 5.375, or 4.625 in (197, 165, 143, or 118 mm)
Valve Type	Ball valve	Ball valve	Ball valve
Hopper Capacity	6 ft ³ (0.17m ³)	5 ft ³ (0.14m ³)	6 ft ³ (0.17m ³)
Maximum Line Size	2 in (50mm), 2.5 in (62 mm)	4 in (100mm)	3 in (75 mm)
Remote Control	Standard	Standard	Standard
	Optional - Radio (Wireless)	Optional - Radio (Wireless)	Optional - Radio (Wireless)
Surge Chamber	-	Standard	-
Engines			
Standard Engine	30 hp (23 kW) Wisconsin Gas	41hp (30kW) Deutz Diesel	30 hp (23 kW) Wisconsin Gas
Optional Engines	30hp (23 kW) Hatz Diesel		20hp (15 kW) Electric 33hp (25 kW) Hatz Diesel
Weight	2200 lbs (999 kg)	3000 lbs (1360 kg)	2360 lbs (1071 kg)
Manufacturer	Reed Concrete Placing Equipment 13822 Oaks Ave. Chino, CA 91708 USA Tel: 909/364-2100 Fax: 909/364-2140	Reinert Manufacturing Co. 7968 Kentucky Drive, Ste. 1 Florence, KY 41042 USA Tel: 606/525-8488 Fax: 606/525-2484	Thomsen Machinery, Inc. 101 South Main Street Gardena, CA 90248 USA Tel: 310/769-4500 Fax: 310/516-9820
Model	B 30	ZR - 424	Putzmeister P 30G
Performance			
Concrete Output	30 yd ³ /hr (23m ³ /hr)	20yd ³ /hr (15m ³ /hr)	25 yd ³ /hr (19 m ³ /hr)
Concrete Pressure	1026 psi (70 Bar.)	625 psi (44 Bar.)	425 psi (29 Bar.)
Horizontal Pumping Distance	-	400 ft (120 m)	400 ft (120 m)
Maximum Aggregate Size	1.5 in (38 mm)	1 in (25 mm)	0.5 in (13 mm)
Pump			
Volume Control	Variable - Adjustable stroke and speed	Variable - Adjustable stroke and speed	Variable - Adjustable stroke and speed
Concrete Cylinder Diameter	6 in (150 mm)	4 in (100 mm)	6 in (150 mm)
Concrete Cylinder Stroke	-	24 in (609 mm)	12 in (305 mm)
Valve Type	S valve	S valve	Ball
Hopper Capacity	10 ft ³ (0.28 m ³)	8 ft ³ (0.23 m ³)	6 ft ³ (0.17m ³)
Maximum Line Size	5 in (125 mm)	3 in (75 mm)	-
Remote Control	-	-	Yes
Surge Chamber	-	-	-
Engines			
Standard Engine	54 hp (40 kW)Deutz Diesel	30 hp (23 kW) Wisconsin Gas	30 hp (23 kW) Wisconsin Gas
Optional Engines			37 hp (27 kW) Hatz Diesel 20hp (15 kW) Electric
Weight	4450 lbs (2019 kg)	2000 lbs (978 kg)	2400 lbs (1090 kg)

APPENDIX 2 - HAND-HELD SEWING MACHINES

Manufacturer	Fischbein Company 151 Walker Road Statesville, N.C. 28625	American-Newlong, Inc. 5310 South Harding Street Indianapolis, IN 46217	Union Special Corporation One Union Special Plaza Huntley, IL 60142
	Tel: 704/871-1159 Fax: 704/872-3303	Tel: 317/787-9421 Fax: 317/786-5225	Tel: 800/344-9698 Fax: 708/669-5804

Model	ECR	NP-7A	2200
Performance			
Stitches per Minute	-	1500-1600	1200-1700
Stitch	Single thread, 101 stitch	Single thread, 101 stitch	Two thread, single needle, 401 stitch or Single thread, 101 stitch
Stitch Length	-	Fixed 3 SPI (8.5 mm)	Adjustable 3-8.5 SPI
Needle	-	DNx1-#25	-
Drive Motors			
AC	115 V, 1.1 amps 220 V, 0.6 amps	60W 50/60Hz, 1-ph., 12V, 24V, 110V, 220V, or 240V	Electric or Pneumatic
DC	12V, 9 amps	12 V	
Pneumatic	Yes	-	-
Weight	11 lbs (5 kg)	12 lbs (5.3 kg)	11 lbs (5.0 kg)

Hydrotex and Hydrocast products are manufactured by:

Geostar Corporation

53 Perimeter Center East, Suite 250

Atlanta, Georgia 30346 (USA)

Tel: 1.800.253.0561 or 770.399.5051 Fax: 770.394.5999

<http://www.geostarcorporation.com> • e-mail: info@geostarcorporation.com

Hydrotex, Hydrocast, Filter Band, and Enviromat are trademarks of Geostar Corporation.

© 2001, Geostar Corporation Printed in U.S.A.

The information contained herein was derived based on the use of products manufactured by Geostar Corporation. Their use or application with the products of another manufacturer is not recommended, due to differences in material composition or differences in manufacturing technique, and may produce unintentioned results. This information is intended for the use of the entity or individual to whom it is addressed and may contain information that is privileged, confidential and exempt for disclosure under applicable law.

The information contained herein is furnished without charge or obligation, and the recipient assumes all responsibility for its use. Because conditions of use and handling may vary and are beyond our control, we make no representation about, and are not responsible for, the accuracy or reliability of said information or the performance of any product. Any specifications, properties or applications listed are provided as information only and in no way modify, enlarge or create any warranty. Nothing contained herein is to be construed as permission or as a recommendation to infringe any patent.

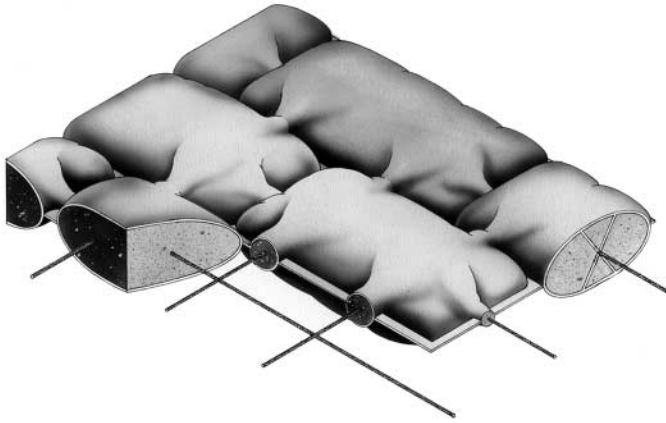

HYDROTEX™

Specification Guideline Fabric-formed Concrete Erosion Control Systems

Articulating Block Mat

Table 1.0 Typical Dimensions and Weights

Articulating Block	AB400	AB600	AB800	AB1000	AB1200
Average Thickness, in (mm)	4.0 (102)	6.0 (152)	8.0 (203)	10 (254)	12 (305)
Mass Per Unit Area, lb/ft ² (kg/m ²)	45 (220)	68 (330)	90 (440)	113 (550)	135 (661)
Mass per Block, lb (kg)	88 (39.8)	188 (85.2)	325 (148)	563 (255)	844 (382)
Nominal Block Dimensions, in (mm)	20 x 14 (508 x 356)	20 x 20 (508 x 508)	20 x 26 (508 x 660)	30 x 24 (762 x 610)	30 x 30 (762 x 762)
Concrete Coverage, ft ² /yd ³ (m ² /m ³)	75 (9.1)	50 (6.1)	38 (4.6)	30 (3.6)	25 (3.0)
Shear Resistance, lb/ft ² (kg/m ²)	26 (127)	39 (190)	52 (254)	65 (317)	78 (381)

Note: Values shown are typical and will vary with weight of concrete and field conditions.

Product Description

Articulating Block Mats form cable-reinforced concrete block mattresses that resist erosive forces. They are often constructed where a revetment is exposed to frontal attack by wave action. AB Mats are typically used to protect coastlines, underwater pipelines, bridge piers, and other marine structures from propeller wash, ship wakes, wind waves, currents, and high velocity flows. They are also used in environmental construction for landfill caps, down chutes, and collector channels.

The AB fabric form consists of a series of compartments, linked by an interwoven perimeter. Ducts interconnect the compartments, and high strength revetment cables are installed between and through the compartments and ducts. Once filled, the AB Mats becomes a mattress of pillow-shaped, rectangular concrete blocks. The interwoven perimeters between the blocks serves as a hinge to permit articulation. The cables remain embedded in the concrete blocks to link the blocks together and facilitate articulation.

Relief of hydrostatic pressure, when required, is accomplished through slits cut between blocks and/or by inserting plastic weep tubes at specified centers prior to filling the form with concrete.

1.0 GENERAL

1.1 Scope of Work: The Contractor shall furnish all labor, materials, equipment, and incidentals required to perform all operations in connection with the installation of the proposed Articulating Block (AB) Lining in accordance with the lines, grades, design, and dimensions shown on the Contract Drawings and as specified herein.

1.2 Description: The work shall consist of installing an unreinforced concrete lining by positioning specially woven, double-layer synthetic forms on the surface to be protected and filling them with a pumpable, fine aggregate concrete (structural grout) in such a way as to form a stable lining of required thickness, weight and configuration.

2.0 MATERIALS REQUIREMENTS

2.1 Fine Aggregate Concrete: Fine aggregate concrete shall consist of a proportioned mixture of Portland cement, fine aggregate (sand) and water. The consistency of the fine aggregate concrete delivered to the concrete pump shall be proportioned and mixed as to have an efflux time of 9-12 seconds when passed through the 0.75 inch (19 mm) orifice of the standard flow cone that is described in ASTM C 939. Pozzolan, fluidifier or pumping aid conforming to this Specification may be used at the option of the Contractor. The mix shall exhibit a compressive strength of 2,000 lb/in² (13.8 MPa) at 28 days, when made and tested in accordance with ASTM C 31 and C 39.

2.1.1 Portland cement shall conform to ASTM C 150, Type I or Type II.

2.1.2 Fine aggregate shall conform to ASTM C 33, except as to grading. Aggregate grading shall be reasonably consistent and shall not exceed the maximum size which can be conveniently handled with available pumping equipment.

2.1.3 Water for mixing shall be clean and free from injurious amounts of oil, acid, salt, alkali, organic matter or other deleterious substances.

PROPERTY REQUIREMENTS - ARTICULATING BLOCK FABRIC^{1, 2}

Property	Test Method	Units	Values
Physical:			
Composition of Yarns			Nylon or polyester
Mass Per Unit Area (double-layer)	ASTM D 5261	oz/yd ² (g/m ²)	12 (403)
Thickness	ASTM D 5199	mils (mm)	25 (0.6)
Mill Width		in (m)	76 (1.92)
Mechanical:			
Wide-Width Strip Tensile Strength	- Machine	ASTM D 4595	lbf/in (kN/m)
	- Cross		lbf/in (kN/m)
Elongation at Break	- Machine	ASTM D 4595	%
	- Cross		%
Trapezoidal Tear Strength	- Machine	ASTM D 4533	lbf (N)
	- Cross		lbf (N)
Hydraulic:			
Apparent Opening Size (AOS)	ASTM D 4751	U.S. Standard Sieve (mm)	40 (0.425)
Flow Rate	ASTM D 4491	gal/min/ft ² (l/min/m ²)	90 (3665)

Notes:

1. *Conformance of fabric to specification property requirements shall be based on ASTM D 4759, "Practice for Determining the Specification Conformance of Geotextiles."*
2. *All numerical values represent minimum average roll values (i.e., average of test results from any sample roll in a lot shall meet or exceed the minimum values). Lots shall be sampled according to ASTM D 4354, "Practice for Sampling of Geosynthetics for Testing."*

2.1.4 Pozzolan, if used, shall conform to ASTM C 618, Class C, F or N.

2.1.5 Plasticizing and air entraining admixtures, if used, shall conform to ASTM C 494 and ASTM C 260, respectively.

2.2 Fabric Forms: The fabric forms shall be as specified, HYDROTEX™ Articulating Block (see Note A) forms as manufactured by Geostar Corporation; 74 Perimeter Center East, Suite 7420; Atlanta, Georgia 30346-1803, Tel: 800.253.0561 (770.399.5051); or approved equal. The fabric forms shall be composed of synthetic yarns formed into a woven fabric. Yarns used in the manufacture of the fabric shall be composed of nylon and/or polyester. Forms shall be woven with a minimum of 50% textured yarns (by weight) to improve adhesion to fine aggregate concrete and to improve filtration. Partially-oriented (POY), draw-textured, and/or staple yarns shall not be used in the manufacture of the fabric. Each layer of fabric shall conform to the physical, mechanical and hydraulic requirements referenced herein. The fabric forms shall be free of defects or flaws which significantly affect their physical, mechanical, or hydraulic properties.

Note A: The engineer shall indicate the Articulating Block Mat size required (see Table 1.0). Example: AB400.

2.2.1 Fabric forms shall consist of double-layer woven fabric joined together by narrow perimeters of interwoven fabric into a matrix of rectangular compartments that form a concrete articulating block mat with finished nominal block dimensions of ___ inches (mm) x ___ inches (mm) (see Table 1.0), a finished average thickness of (see Table 1.0) inches (mm) and a nominal mass per unit area of (see Table 1.0) lb/ft² (kg/m²). Cords shall connect the two layers of fabric at the center of each compartment. The cords shall be interwoven in two sets of four cords each, one set for the upper layer and one set for the bottom layer. Each cord shall have a minimum breaking strength of 160 lbf (710 N) when tested in accordance with ASTM D 2256. Fabric form compartments shall be offset one half a com-

partment length, in the mill width direction, to form a bonded concrete block pattern.

2.2.2 Fabric form compartments shall each have six ducts, two on each of the long sides and one on each of the short sides to allow passage of the fine aggregate concrete between adjacent compartments. The fine aggregate concrete filled, cross-sectional area of each duct shall be no more than 10 percent of the maximum filled cross sectional area of the block transverse to the duct.

2.2.3 Mill widths of fabric shall be a minimum of 76 inches (1.92 m). Each selvage edge of the top and bottom layers of fabric shall be reinforced for a width of not less than 1.35 inches (35 mm) by adding a minimum of 6 warp yarns to each selvage construction. Mill width rolls shall be cut to the length required, and the double-layer fabric separately joined, bottom layer to bottom layer and top layer to top layer, by means of sewing thread, to form multiple mill width panels with sewn seams on not less than 72 inch (182 cm) centers.

2.2.4 All factory-sewn seams shall be downward facing as shown on the Contract Drawings. All seams sewn in the factory shall be not less than 90 lbf/in (15.7 kN/m) when tested in accordance with ASTM D 4884. All sewn seams and zipper attachments shall be made using a double line of U.S. Federal Standard Type 401 stitch. All stitches shall be sewn simultaneously and be parallel to each other, spaced between 0.25 inches (6 mm) to 0.75 inches (19 mm) apart. Each row of stitching shall consist of 4 to 7 stitches per inch (per 25.4 mm). Thread used for seaming shall be nylon and/or polyester.

2.2.5 Baffles shall be installed at predetermined mill width intervals to regulate the distance of lateral flow of fine aggregate concrete. The baffle material shall be nonwoven filter fabric. The grab tensile strength of the filter fabric shall be not less than 90 lbf/in (400 N) when tested in accordance with ASTM D 4632.

2.2.6 Fabric Form Shipment and Storage: The fabric forms shall be kept dry and wrapped such that they are protected from the elements during shipping and storage. If stored outdoors, they shall be elevated and protected with a waterproof cover that is opaque to ultraviolet light. The fabric forms shall be labeled as per ASTM D 4873, "Guide for Identification, Storage and Handling of Geosynthetic Rolls."

2.2.7 Cables shall be installed in the longitudinal direction between the two layers of fabric. A minimum of two longitudinal cables shall pass through each compartment in a manner which provides for the longitudinal and lateral binding of the finished articulating block mat. The cables shall enter and exit the compartments through opposing ducts. The longitudinal cables shall be on approximately 10 inch (25 cm) centers, when measured along the finished mat. All cables within each filled concrete block shall be completely embedded in the fine aggregate concrete.

2.2.8 Cables shall be constructed of high tenacity, low elongation, continuous filament polyester fibers. Cables shall be nominally ____ inches (mm) in diameter and their rated breaking strength shall be not less than ____ lbf (N).

2.2.9 Cable fittings shall be selected so that the resultant cable splice shall provide a minimum of 80 percent of the rated breaking strength of the cable. All cable splices shall have a minimum cable overlap of 6 inches (15.3 cm) and be made with aluminum compression fittings.

2.2.10 The Contractor shall submit a manufacturer's certificate that the supplied fabric forms meet the criteria of these Specifications, as measured in full accordance with the test methods and standards referenced herein. The certificates shall include the following information about each fabric form delivered:

- Manufacturer's name and current address;
- full product name;
- style and product code number;
- form number(s);
- composition of yarns; and
- manufacturer's certification statement.

2.3 Filter Fabrics: The filter fabrics shall be composed of synthetic fibers or yarns formed into a nonwoven or woven fabric. Fibers and yarns used in the manufacture of filter fabrics shall be composed of at least 85% by weight of polypropylene, polyester or polyethylene. They shall be formed into a network such that the filaments or yarns retain dimensional stability relative to each other, including selvages. These materials shall conform to the physical requirements shown below. The filter fabric shall be free of defects or flaws which significantly affect its mechanical or hydraulic properties.

PROPERTY REQUIREMENTS - FILTER FABRIC ^{1, 2}			
Property	Test Method	Units	Values
Grab Tensile Strength	ASTM D 4632	lbf (N)	90 (400)
Elongation at Break	ASTM D 4632	%	15
Trapezoidal Tear Strength	ASTM D 4533	lbf (N)	30 (130)
Permittivity	ASTM D 4491	sec ⁻¹	0.5

Notes:

1. Conformance of filter fabrics to specification property requirements shall be based on ASTM D 4759, "Practice for Determining the Specification Conformance of Geotextiles."
2. All numerical values represent minimum average roll values (i.e., average of test results from any sample roll in a lot shall meet or exceed the minimum values). Lots shall be sampled according to ASTM D 4354, "Practice for Sampling of Geosynthetics for Testing."

3.0 DESIGN REQUIREMENTS

Note B: Select the appropriate pair of paragraphs for the final specification based upon the type of hydraulic application.

The average thickness, mass per unit area and hydraulic resistance of each concrete lining shall withstand the hydraulic loadings (velocity, depth, duration, shear stress, pressure, and frequency of immersion) for the design discharges along the structure(s). The stability analysis for each concrete lining shall be accomplished using a factor-of-safety methodology. A minimum factor of safety of 1.5 shall be required.

The Contractor shall provide to the Engineer calculations and design details, provided by the manufacturer or a professional engineer, attesting to the suitability of each fabric formed concrete lining for the purpose contemplated. Each concrete lining shall be accepted only when accompanied by the documented hydraulic performance characteristics derived from tests performed under controlled flow conditions. Test conditions shall conform to test protocol as documented in "Hydraulic Stability of Fabric Formed Concrete Lining and Mat Systems During Over-topping Flow."

or

The average thickness, mass per unit area and hydraulic resistance of each concrete lining shall withstand the hydraulic loadings (depth, duration, type of wave, wave height and period, and pressure distribution) for the design wave. The stability analysis for the concrete lining shall be accomplished using the factor-of-safety methodology. A minimum factor of safety of 1.5 shall be required.

The Contractor shall provide to the Engineer calculations and design details, provided by the manufacturer or a professional engineer, attesting to the suitability of each fabric formed concrete lining for the purpose contemplated. Each concrete lining shall be accepted only when accompanied by hydraulic stability calculations derived from mathematical models developed specifically for fabric formed concrete linings and for this purpose.

4.0 CONSTRUCTION AND INSTALLATION REQUIREMENTS

4.1 Site Preparation

4.1.1 Areas on which fabric forms are to be placed shall be constructed to the lines, grades, contours, and dimensions shown on the Contract Drawings. All obstructions such as roots and projecting stones shall be removed. Where such areas are below the allowable grades, they shall be brought to grade by placing compacted layers of select material. The thickness of layers and the amount of compaction shall be as specified by the Engineer. Where required by the Contract Specifications, soft and otherwise unsuitable subgrade soils shall be identified, excavated and replaced with select materials in accordance with the Contract Specifications.

4.1.2 Excavation and preparation of aprons as well as anchor, terminal or toe trenches shall be done in accordance with the lines, grades, contours, and dimensions shown on the Contract Drawings.

4.1.3 Immediately prior to placing the fabric forms, the prepared area shall be inspected by the Engineer, and no forms shall be placed thereon until the area has been approved.

4.2 Fabric Form Placement

4.2.1 A filter fabric shall be placed on the graded surface

approved by the Engineer.

- 4.2.2 Fabric forms shall be placed over the filter fabric and within the limits shown on the Contract Drawings. Anchoring of the fabric forms shall be accomplished through the use of anchor, terminal and toe trenches.
- 4.2.3 Adjacent fabric form panels shall be joined before filling with fine aggregate concrete by field sewing or zipping the two bottom layers of fabric together and the two top layers of fabric together. All field seams shall be made using two lines of U.S. Federal Standard Type 101 stitches. All sewn seams shall be downward facing, and zipper seams shall be fastened as shown on the Contract Drawings, except with the approved of the Engineer.
- 4.2.4 When conventional joining of fabric forms is impractical or where called for in the Contract Drawings, adjacent forms may be overlapped a minimum of three feet (one meter) to form a lap joint, pending approval by the Engineer. Based on the predominant flow direction, the downstream edge of the form shall overlap the upstream edge of the next form. In no case shall simple butt joints between forms be permitted.
- 4.2.5 Expansion joints shall be provided as shown on the Contract Drawings, or as specified by the Engineer.
- 4.2.6 Immediately prior to filling with fine aggregate concrete, the assembled fabric forms shall be inspected by the Engineer, and no fine aggregate concrete shall be pumped therein until the fabric seams have been approved. At no time shall the unfilled fabric forms be exposed to ultraviolet light (including direct sunlight) for a period exceeding five days.

4.3 Fine Aggregate Concrete Placement

- 4.3.1 Following the placement of the fabric forms, small slits shall be cut in the top layer of the fabric form to allow the

insertion of the filling pipe at the end of the fine aggregate concrete pump hose. These slits shall be of the minimum length to allow proper insertion of the filling pipe. Fine aggregate concrete shall be pumped between the top and bottom layers of fabric, filling the forms to the recommended thickness and configuration.

- 4.3.2 Fine aggregate concrete shall be pumped in such a way that excessive pressure on the fabric forms and cold joints are avoided. A cold joint is defined as one in which the pumping of the fine aggregate concrete into a given form is discontinued or interrupted for an interval of forty-five or more minutes.
- 4.3.3 Holes in the fabric forms left by the removal of the filling pipe shall be temporarily closed by inserting a piece of nonwoven fabric or similar material. The nonwoven fabric shall be removed when the concrete is no longer fluid and the concrete surface at the hole shall be cleaned and smoothed by hand. Foot traffic on the filled form shall be restricted to an absolute minimum for one hour after filling.
- 4.3.4 After the fine aggregate concrete has set, all anchor, terminal and toe trenches shall be backfilled and compacted, as specified by the Engineer.
- 4.3.5 The Articulating Block Mat shall be measured by the number of square feet (square meters) computed from the payment lines shown on the Contract Drawings or from payment lines established in writing by the Engineer. This includes Articulating Block fabric forms, fine aggregate concrete, and filter fabric used in the aprons, overlaps, and anchor, terminal, or toe trenches. Slope preparation, excavation and backfilling, and bedding are separate pay items.

Spec: AB
Revised December 2001

Call or write for your complete set of HYDROTEX™ and HYDROCAST™ Specification Guidelines. Available as printed specifications, in Adobe® Acrobat® (pdf) format, or in an editable text format. PDF specifications are available for download from our web site at www.geostarcorporation.com.

Hydrotex products are manufactured by:

Geostar Corporation
74 Perimeter Center East, Suite 7420
Atlanta, Georgia 30346-1803
Tel: 1.800.253.0561 or 770.399.5051 Fax: 770.394.5999
www.geostarcorporation.com • e-mail: info@geostarcorporation.com

Hydrotex and Hydrocast are trademarks of Geostar Corporation.

© 2001 Geostar Corporation • Printed in U.S.A.

The information contained herein is furnished without charge or obligation, and the recipient assumes all responsibility for its use. Because conditions of use and handling may vary and are beyond our control, we make no representation about, and are not responsible for, the accuracy or reliability of said information or the performance of any product. Any specifications, properties or applications listed are provided as information only and in no way modify, enlarge or create any warranty. Nothing contained herein is to be construed as permission or as a recommendation to infringe any patent.

